

VANDENS SIURBLIAI, UAB  
Įmonės kodas 144708571  
PVM kodas LT447085716  
Girulių g. 24, Šiauliai  
LT78138, Lietuva



## **MECHANINIS SANDARIKLIS TSCR-22 SSIC/SSIC/VITON/SS304 - 175.22 €**

**Gamintojas**

---



### **APRAŠYMAS:**

---

Sandarikliai: TS CR serija Veikimo ribos: Slėgis:  $\leq 1,0\text{MPa}$  Sukimosi greitis:  $\leq 10\text{m / s}$  Temperatūra:  $-30\text{ °C} \sim + 180\text{ °C}$  Medžiagos: Sukamasis žiedas (SiC / TC) Stacionarus žiedas (SiC / TC) Antrinis sandariklis (NBR / VITON) Spyruoklė ir kitos dalys (SUS304 / SUS316) Šie mechaniniai sandarikliai naudojami nerūdijančio plieno vertikaliems daugiapakopiams išcentriniamsi siurbliams. Jie yra tinkami naudoti „Grundfos“ siurbliuose: CR1 / CR3 / CR5 / CR10 / CR15 / CR20 / CR32 / CR45 / CR64 / CR90 vandens siurbLIAI, O-žiedo tipo CRN1 / CRN3 / CRN5 / CRN10 / CRN15 / CRN20 / CRN32 / CRN45 / CRN64 / CRN90 vandens siurbLIAI, O-žiedo tipo Matmenys:

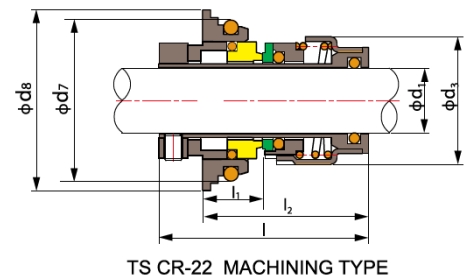
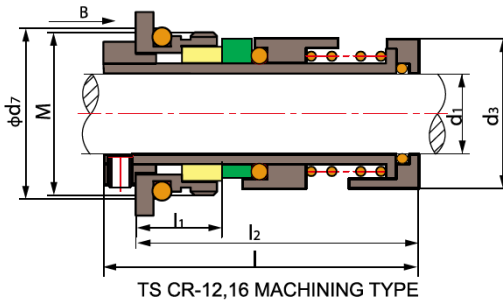
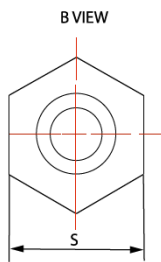
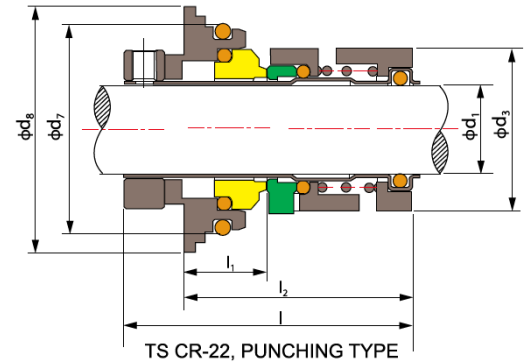
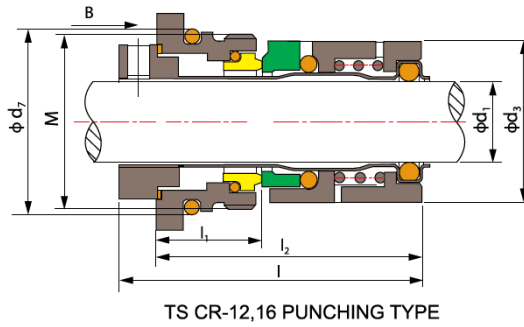

**Operating Limits**

Pressure:  $\leq 1.0\text{MPa}$   
 Speed:  $\leq 10\text{m/s}$   
 Temperature:  $-30^{\circ}\text{C} \sim +180^{\circ}\text{C}$

- Rotary Ring (SiC/TC)
- Stationary Ring (SiC/TC)
- Secondary Seal (NBR/VITON)
- Spring & Other Parts (SUS304/SUS316)

Model	$d_1$	$d_3$	$d_7$	$d_6$	M	I	$l_1$	$l_2$	S
CR-12	12	25.0	29	\	M28X1.5	55	19	29.0	35.8
CR-16	16	30.5	34	\	M33X1.5	57.5	20	30.5	40.8
CR-22 PUNCH	22	39.0	50	59	\	70.0	20	55.0	\
CR-22 MACHINING	22	42.0	50	60	\	70.0	20	55.0	\

**Mechanical seals used for stainless steel vertical multistage centrifugal pump**

It is suitable to GRUNDFOS pumps.

CR1, 3, 5, 10, 15, 20, 32, 45, 64, 90 Ordinary machine—seal of water pump, O ring assembly type;  
 CRN1, 3, 5, 10, 15, 20, 32, 45, 64, 90 Ordinary machine—seal of water pump, O ring assembly type;

NEW

TRISUN

www.trisunltd.com  
ISO9001 & TS16949



金属件冲压  
PUNCHING TYPE



金属件车加工  
MACHINING TYPE

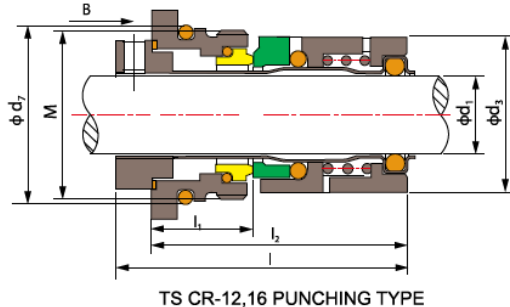

TS CR-12,16 PUNCHING TYPE

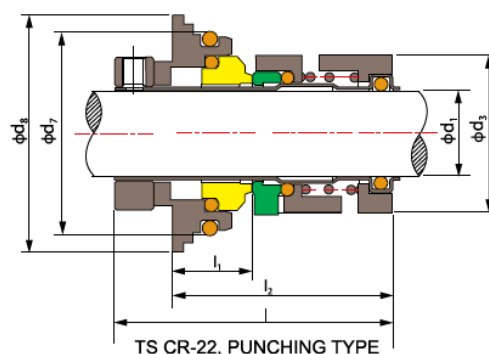

TS CR-22, PUNCHING TYPE

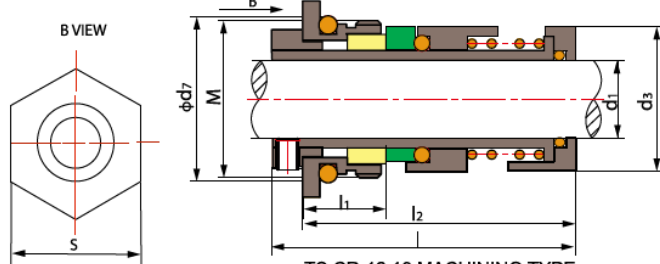

TS CR-12,16 MACHINING TYPE

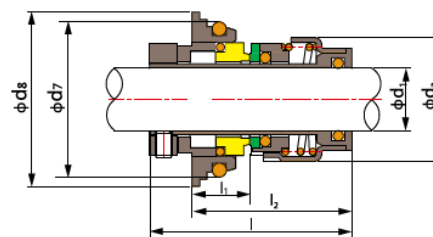

TS CR-22 MACHINING TYPE

## TS CR

### 技术参数:

压力:  $\leq 1.0\text{MPa}$   
线速度:  $\leq 10\text{m/s}$   
温度:  $-30^{\circ}\text{C} \sim +180^{\circ}\text{C}$

- 动环(碳化硅/碳化钨)
- 静环(碳化硅/碳化钨)
- 辅助密封(丁腈胶/氟胶)
- 弹簧及其他金属件(不锈钢)

### Operating Limits

Pressure:  $\leq 1.0\text{MPa}$   
Speed:  $\leq 10\text{m/s}$   
Temperature:  $-30^{\circ}\text{C} \sim +180^{\circ}\text{C}$

- Rotary Ring (SiC/TC)
- Stationary Ring (SiC/TC)
- Secondary Seal(NBR/VITON)
- Spring & Other Parts(SUS304/SUS316)

Model	$d_1$	$d_3$	$d_7$	$d_8$	M	l	$l_1$	$l_2$	S
CR-12	12	25.0	29	\	M28X1.5	55	19	29.0	35.8
CR-16	16	30.5	34	\	M33X1.5	57.5	20	30.5	40.8
CR-22 PUNCH	22	39.0	50	59	\	70.0	20	55.0	\
CR-22 MACHINING	22	42.0	50	60	\	70.0	20	55.0	\

### 不锈钢立式多级离心泵用机械密封

适配于格兰富:

CR1, 3, 5, 10, 15, 20, 32, 45, 64, 90 水泵常规机封, O形圈集装箱式结构

CRN1, 3, 5, 10, 15, 20, 32, 45, 64, 90 水泵常规机封, O形圈集装箱式结构

### Mechanical seals used for stainless steel vertical multistage centrifugal pump

It is suitable to GRUNDFOS pumps.

CR1, 3, 5, 10, 15, 20, 32, 45, 64, 90 Ordinary machine—seal of water pump, O ring assembly type;

CRN1, 3, 5, 10, 15, 20, 32, 45, 64, 90 Ordinary machine—seal of water pump, O ring assembly type;