

VANDENS SIURBLIAI, UAB  
Įmonės kodas 144708571  
PVM kodas LT447085716  
Girulių g. 24, Šiauliai  
LT78138, Lietuva

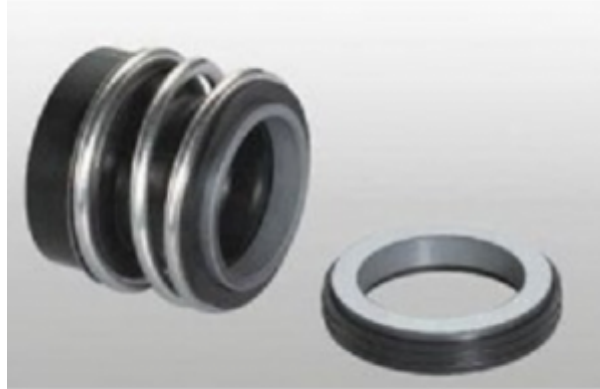

## MECHANINIS SANDARIKLIS TSMG12-32 - 70.08 €

### Gamintojas

---



### APRAŠYMAS:

---

Mechaninis sandariklis modelis MG1 gali pakeisti „AESSEAL B02“, „BURGMANN MG1“, „FLOWSERVE 190“ ir „MTU FG1“, kuris yra plačiai naudojamas „Hecker HN 410SU“ ir kitų rūšių siurbliams. Įprastas medžiagų derinys apima: anglis / keramika / nbr / ss304, anglies dervos / keramika / nbr / ss304 /, sic / sic / nbr / ss304, tc / tc / nbr / ss316 ir pan. Mechaninis sandariklis modelis MG12 gali pakeisti „AESSEAL B012“, „BURGMANN MG12“, „FLOWSERVE 192“ ir „MTU FG2“, kuris yra plačiai naudojamas „Hecker HN 410KU“ ir kitų rūšių siurbliams. Įprastas medžiagų derinys apima: anglis / keramika / nbr / ss304, anglies dervos / keramika / nbr / ss304 /, sic / sic / nbr / ss304, tc / tc / nbr / ss316 ir pan. TS MG1 (TSG) TS MG12 (TSG2) Sukamasis žiedas (anglis / SiC / TC) Stacionarus žiedas (keramikinis / SiC / TC) Antrinis sandariklis (NBR / EPDM / VITON) Spyruoklė ir kitos dalys (SUS304 / SUS316) TS MG1 TS MG12 serijos mechaninių sandariklių veikimo ribos: Slėgis: ≤1,2MPa Greitis: ≤10m / s Temperatūra: -20 °C ~ + 120 °C Gamintojas:

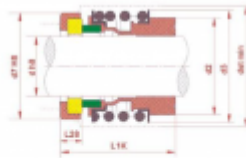

Mat size (mm)	Thickness				
	L	H <sub>1</sub>	H <sub>2</sub>	H <sub>3</sub>	H <sub>4</sub>
10	10	20.0	20.0	20.0	20.0
15	15	20.0	20.0	20.0	20.0
20	20	20.0	20.0	20.0	20.0
25	25	20.0	20.0	20.0	20.0
30	30	20.0	20.0	20.0	20.0
35	35	20.0	20.0	20.0	20.0
40	40	20.0	20.0	20.0	20.0
45	45	20.0	20.0	20.0	20.0
50	50	20.0	20.0	20.0	20.0
55	55	20.0	20.0	20.0	20.0
60	60	20.0	20.0	20.0	20.0
65	65	20.0	20.0	20.0	20.0
70	70	20.0	20.0	20.0	20.0
75	75	20.0	20.0	20.0	20.0
80	80	20.0	20.0	20.0	20.0
85	85	20.0	20.0	20.0	20.0
90	90	20.0	20.0	20.0	20.0
95	95	20.0	20.0	20.0	20.0
100	100	20.0	20.0	20.0	20.0
105	105	20.0	20.0	20.0	20.0
110	110	20.0	20.0	20.0	20.0
115	115	20.0	20.0	20.0	20.0
120	120	20.0	20.0	20.0	20.0
125	125	20.0	20.0	20.0	20.0
130	130	20.0	20.0	20.0	20.0
135	135	20.0	20.0	20.0	20.0
140	140	20.0	20.0	20.0	20.0
145	145	20.0	20.0	20.0	20.0
150	150	20.0	20.0	20.0	20.0
155	155	20.0	20.0	20.0	20.0
160	160	20.0	20.0	20.0	20.0
165	165	20.0	20.0	20.0	20.0
170	170	20.0	20.0	20.0	20.0
175	175	20.0	20.0	20.0	20.0
180	180	20.0	20.0	20.0	20.0
185	185	20.0	20.0	20.0	20.0
190	190	20.0	20.0	20.0	20.0
195	195	20.0	20.0	20.0	20.0
200	200	20.0	20.0	20.0	20.0

[TRISUN](#) Sandariklio matmenys pateikti lentelėje:

## TS MG1(TSG) TS MG12(TSG2)

技术参数:

压力:  $\leq 1.2\text{MPa}$

线速度:  $\leq 10\text{m/s}$

温度:  $-20^{\circ}\text{C} \sim +120^{\circ}\text{C}$

### Operating Limits

Pressure:  $\leq 1.2\text{MPa}$

Speed:  $\leq 10\text{m/s}$

Temperature:  $-20^{\circ}\text{C} \sim +120^{\circ}\text{C}$

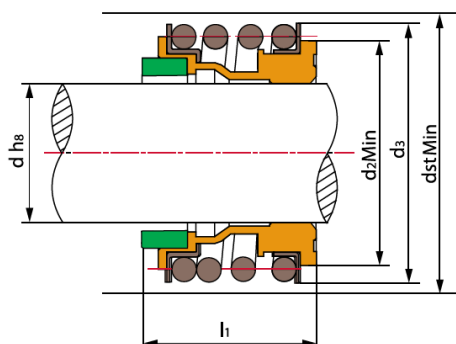

- 动环(石墨/碳化硅/碳化钨)
- 静环(陶瓷/碳化硅/碳化钨)
- 辅助密封(丁腈胶/三元乙丙胶/氟胶)
- 弹簧及其它金属件(不锈钢)

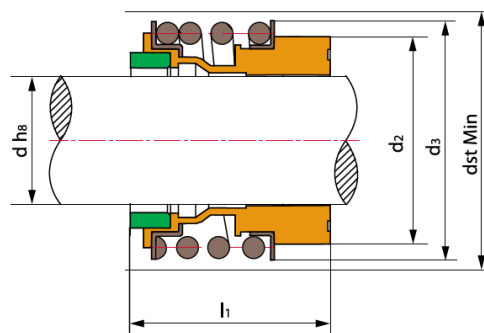

- Rotary Ring (Carbon/SiC/TC)
- Stationary Ring (Ceramic/SiC/TC)
- Secondary Seal (NBR/EPDM/ITON)
- Spring & Other Parts (SUS304/SUS316)

TS MG1					
Seal size d(mm)	d	d <sub>2</sub>	d <sub>3</sub>	d <sub>st</sub>	l <sub>1</sub>
8	8	17.5	19.0	23	12.5
10	10	20.5	22.5	24	14.5
12	12	22.5	25.0	26	15.0
14	14	26.5	28.5	30	17.0
15	15	26.5	28.5	30	17.0
16	16	26.5	28.5	30	17.0
18	18	29.0	32.0	33	19.5
19	19	33.0	37.0	38	21.5
20	20	33.0	37.0	38	21.5
22	22	33.0	37.0	38	21.5
24	24	38.0	42.5	44	22.5
25	25	38.0	42.5	44	23.0
28	28	44.0	49.0	50	26.5
30	30	44.0	49.0	50	26.5
32	32	46.0	53.5	55	27.5
33	33	46.0	53.5	55	27.5
35	35	50.0	57.0	59	28.5
38	38	53.0	59.0	61	30.0
40	40	55.0	62.0	64	30.0
42	42	58.0	65.5	67	30.0
43	43	58.0	65.5	67	30.0
45	45	60.0	68.0	70	30.0
48	48	63.0	70.5	74	30.5
50	50	65.0	74.0	77	30.5
53	53	70.0	78.5	81	33.0
55	55	72.0	81.0	83	35.0
58	58	75.0	85.5	88	37.0
60	60	79.0	88.5	91	38.0
65	65	84.0	93.5	96	40.0
68	68	88.0	96.5	100	40.0
70	70	90.0	99.5	103	40.0
75	75	95.0	107.0	110	40.0
80	80	100.0	112.0	116	40.0
85	85	107.0	120.0	124	41.0
90	90	114.0	127.0	131	45.0
95	95	119.0	132.0	136	46.0
100	100	124.0	137.0	140	47.0

TS MG12					
Seal size d(mm)	d	d <sub>2</sub>	d <sub>st</sub>	d <sub>3</sub>	l <sub>1</sub>
10	10	20.5	24	22.5	25.9
12	12	22.5	26	25.0	25.9
14	14	26.5	30	28.5	28.4
16	16	26.5	30	28.5	28.4
18	18	29.0	33	32.0	30.0
20	20	33.0	38	37.0	30.0
22	22	33.0	38	37.0	30.0
24	24	38.0	44	42.5	32.5
25	25	38.0	44	42.5	32.5
28	28	44.0	50	49.0	35.0
30	30	44.0	50	49.0	35.0
32	32	46.0	55	53.5	35.0
33	33	46.0	55	53.5	35.0
35	35	50.0	59	57.0	35.0
38	38	53.0	61	59.0	36.0
40	40	55.0	64	62.0	36.0
43	43	58.0	67	65.5	36.0
45	45	60.0	70	68.0	36.0
48	48	63.0	74	70.5	36.0
50	50	65.0	77	74.0	38.0
53	53	70.0	81	78.5	36.5
55	55	72.0	83	81.0	36.5
58	58	75.0	88	85.5	41.5
60	60	79.0	91	88.5	41.5
65	65	84.0	96	93.5	41.5
68	68	88.0	100	96.5	41.2
70	70	90.0	103	99.5	48.7
75	75	95.0	110	107.0	48.7
80	80	100.0	116	112.0	48.0
85	85	107.0	124	120.0	46.0
90	90	114.0	131	127.0	51.0
95	95	119.0	136	132.0	51.0
100	100	124.0	140	137.0	51.0