

DC 160-310

DCT 410-1000

DCT 410-1000/P



Centrifugal drainage high head pumps ideal for civil and industrial applications, specifically designed for very heavy use. Available in the mobile or permanent versions with coupling feet.

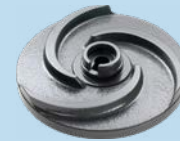

Grey water

Construction features

Pump body cast iron



Impeller cast iron

Mechanical seal

double seal with oil barrier: silicon carbide on pump side, ceramic-graphite on motor side

Motor shaft stainless steel AISI 304

Free passage 10 mm

Max submergence max 20 m

Liquid temperature 0 - 40 °C

Cable H05 RN8F, 10 m

Bolts A2 stainless steel

Foot support galvanized iron

Gaskets NBR rubber

Motor

3~ 230/400V-50Hz P ≤ 4kW

3~ 400/690V-50Hz P > 4kW

2 Poles induction motor

1~ 230V-50Hz
required run capacitor
(35µF for 1,5HP model,
50µF for 2HP model)

Insulation class F

Protection degree IPX8

TYPE	LOTS			
	TRUCK		CONTAINER	
	PALLET (cm)	N° pumps	PALLET (cm)	N° pumps
DC 160-310	85×110×145	18	85×110×190	27
DCT 410-560	85×110×170	12	85×110×170	12
DCT 750-1000	100×120×190	12	100×120×190	12



DC

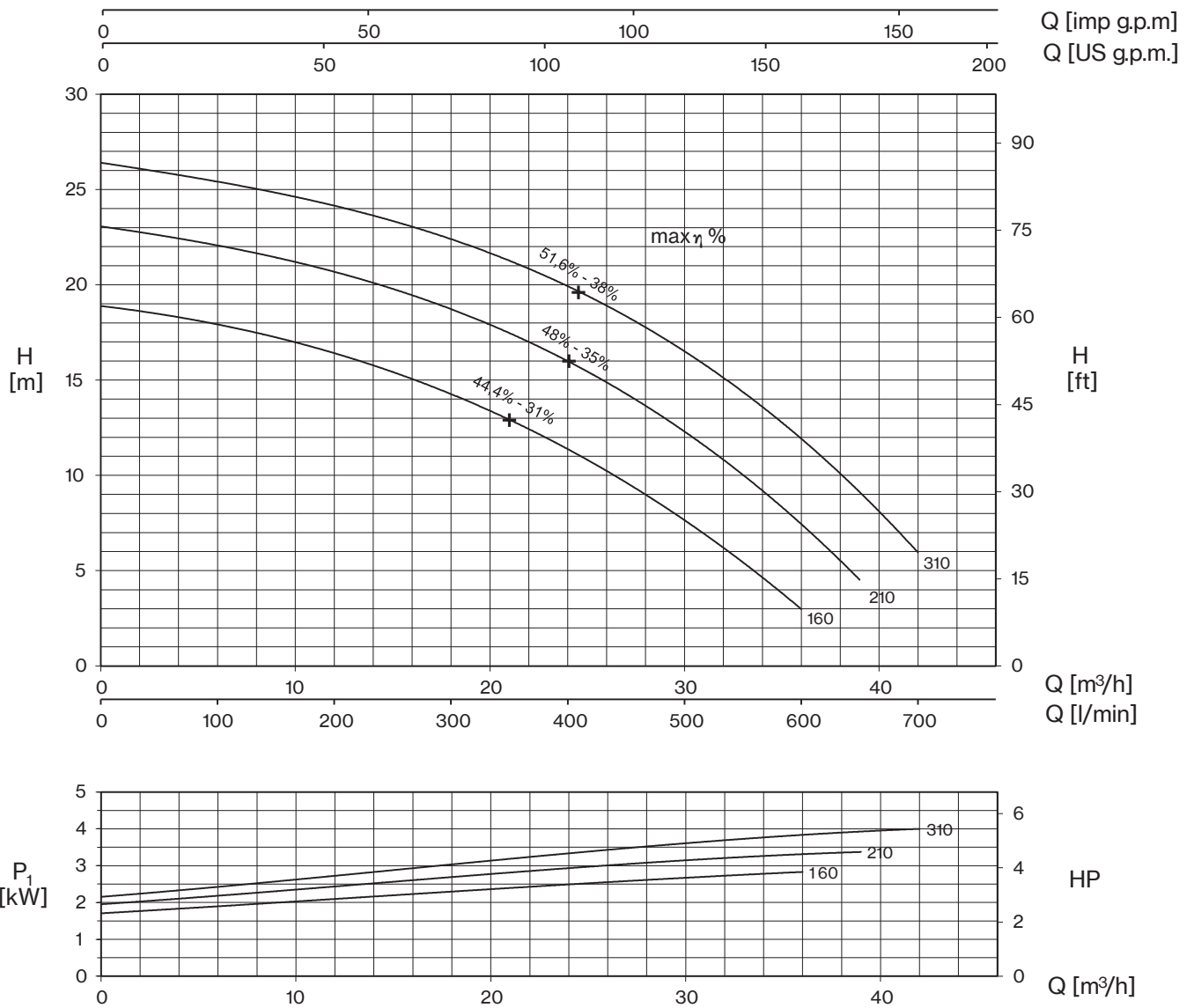

TYPE		AMPERE				
1~	3~	230 V 50 Hz	3x230 V 50 Hz (*)	3x400 V 50 Hz	230/400 V 50 Hz λ / Δ (*)	400/690 V 50 Hz λ / Δ
DC 160	DCT 160	13,8	8,3	4,8	-	-
DC 210	DCT 210	16,5	10,2	5,9	-	-
-	DCT 310	-	12	6,9	-	-

+ max η %

max hydraulic efficiency and respective total efficiency

(*) no standard execution

TYPE		P2		P1 (kW)		Q (m³/h - l/min)								
1~	3~	HP	kW	1~	3~	0	6	12	18	24	30	36	39	42
						0	100	200	300	400	500	600	650	700
						H (m)								
DC 160	DCT 160	1,5	1,1	3,0	2,8	18,9	17,9	16,4	14,3	11,4	7,6	3,0		
DC 210	DCT 210	2	1,5	3,7	3,4	23,0	22,2	20,7	18,6	15,9	12,5	7,4	4,5	
-	DCT 310	3	2,2	-	4,0	26,4	25,4	24,2	22,4	19,9	16,4	12,1	9,1	5,9



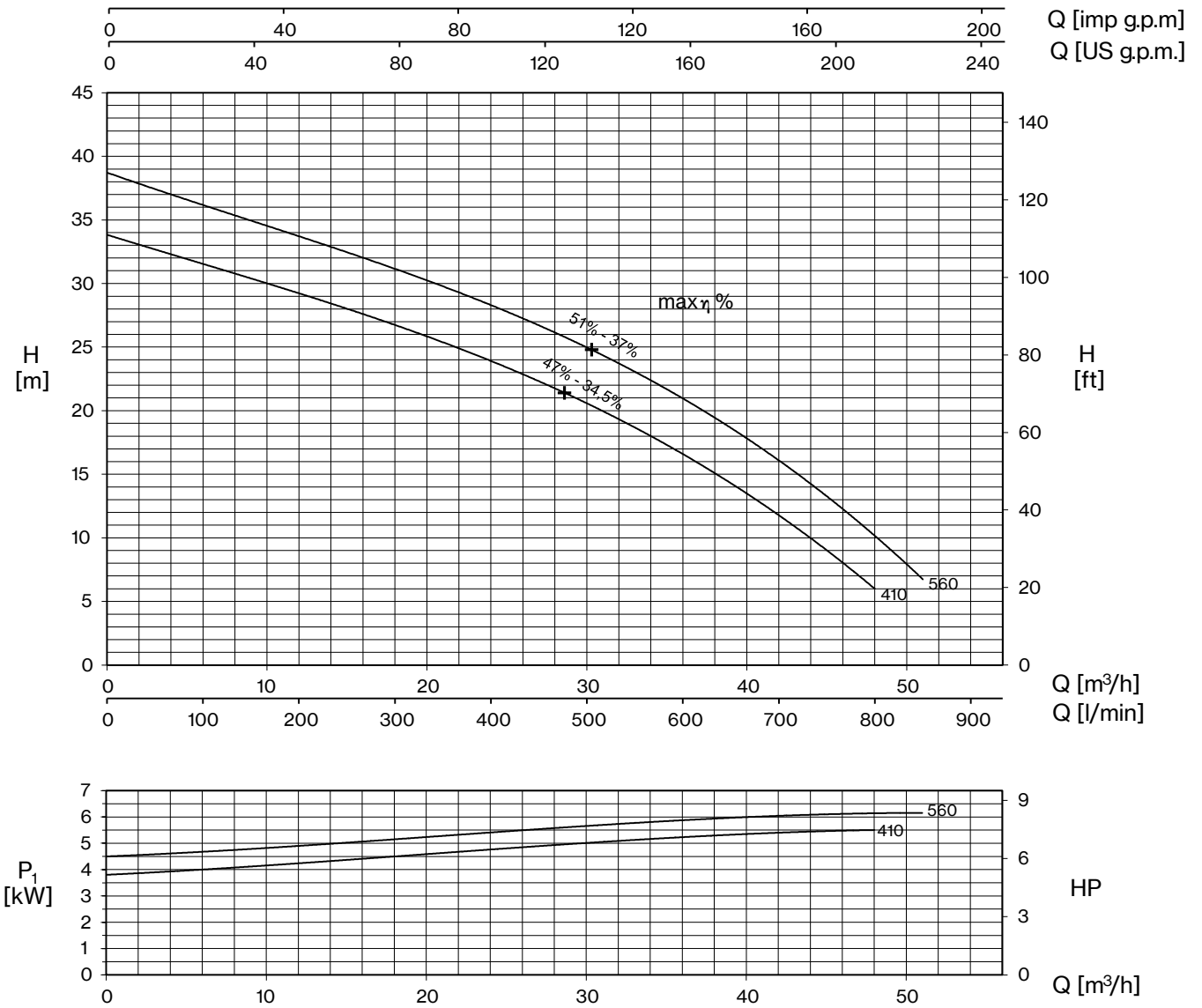

TYPE	AMPERE			
	3x230 V 50 Hz (*)	3x400 V 50 Hz	230/400 V 50 Hz λ / Δ (*)	400/690 V 50 Hz λ / Δ
DCT 410	15,4	8,9	-	-
DCT 560	17,6	10,2	-	-

(*) no standard execution

+ max η %

max hydraulic efficiency and respective total efficiency

TYPE	P2		P1 (kW)	Q (m³/h - l/min)										
				0	6	12	18	24	30	36	42	48	51	
	HP	kW	3~	0	100	200	300	400	500	600	700	800	850	
DCT 410	4	3	5,5	33,8	31,6	29,2	26,8	23,9	20,5	16,5	12,0	5,9		
DCT 560	5,5	4	6,3	38,7	36,1	33,9	31,2	28,3	24,7	20,9	16,3	10,4	6,5	



DC

Q [imp g.p.m]
Q [US g.p.m.]

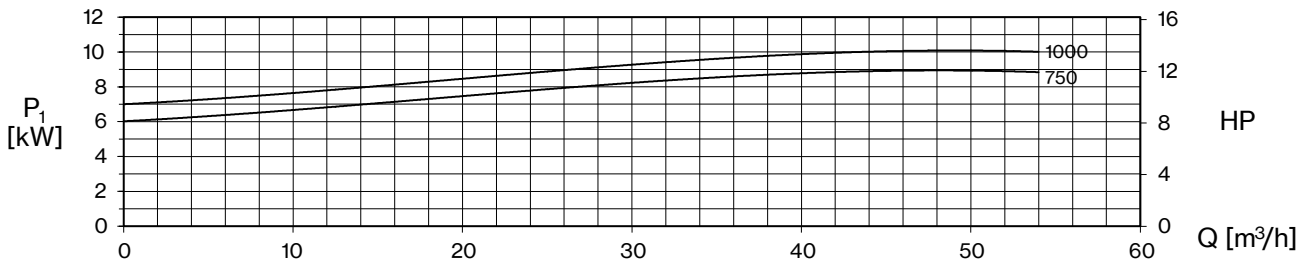
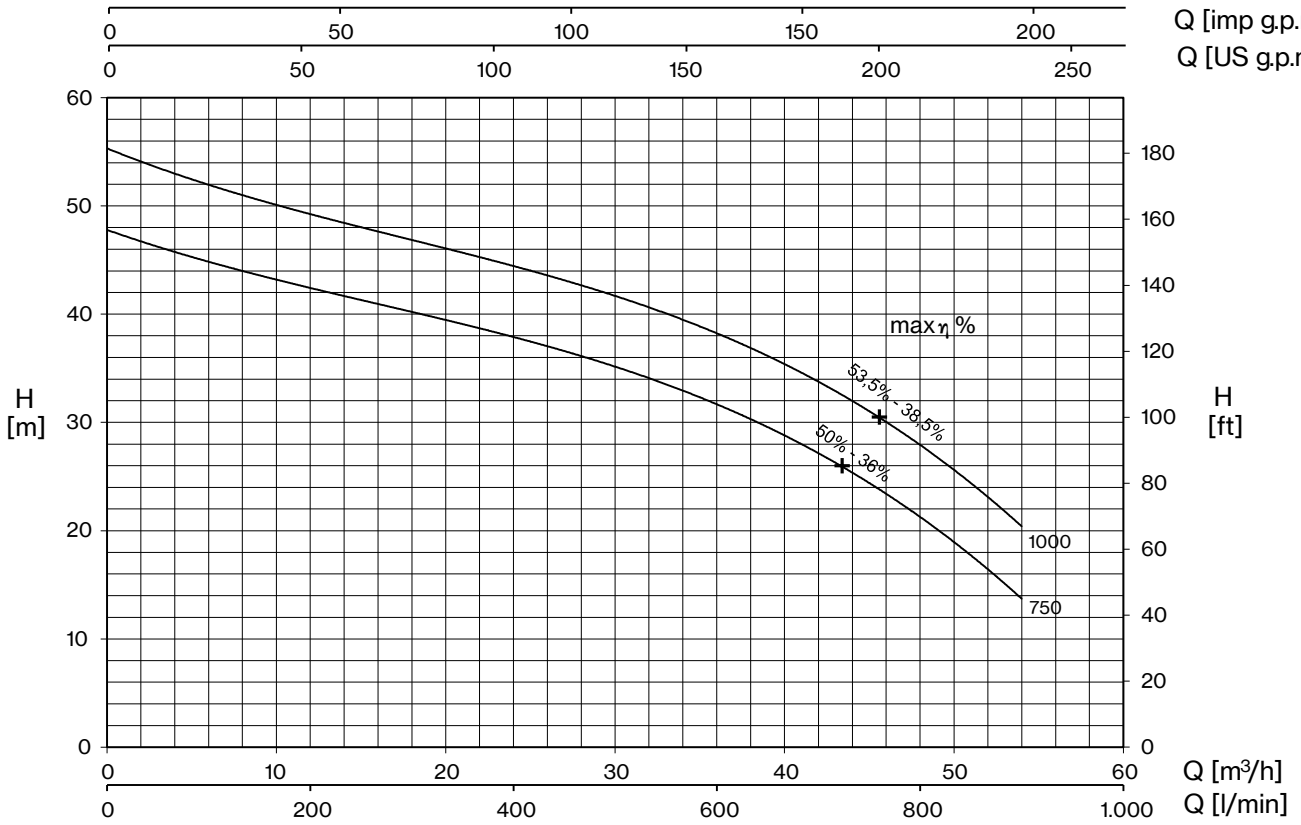

TYPE	AMPERE			
	3x230 V 50 Hz (*)	3x400 V 50 Hz	230/400 V 50 Hz λ / Δ (*)	400/690 V 50 Hz λ / Δ
DCT 750	-	15,3	26,5	15,3
DCT 1000	-	17,5	30,3	17,5

+ max η %

max hydraulic efficiency and respective total efficiency

(*) no standard execution

TYPE	P2		P1 (kW)	Q (m³/h - l/min)									
				0	12	18	24	30	36	42	48	54	
	HP	kW	3~	0	200	300	400	500	600	700	800	900	
DCT 750	7,5	5,5	9,0	47,6	42,9	40,4	37,7	34,7	31,2	27,4	22,3	13,1	
DCT 1000	10	7,5	10,3	55,1	49,8	47,1	44,2	41,1	37,8	34,0	29,1	19,7	



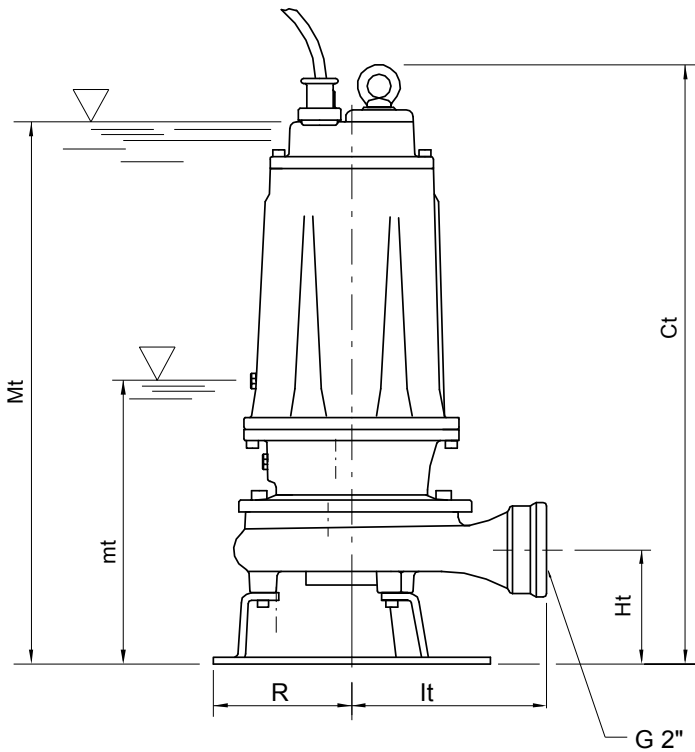

mt/mf: minimum working level
 Mt/Mf: minimum submersion level for continuous duty

TYPE	DIMENSIONS (mm)							Kg
	Ct	Ht	R	lt	mt	Mt	DNM	
DC 160 - DCT 160	513	102	117	174	205	475	2"G	37
DC 210 - DCT 210	513	102	117	174	205	475	2"G	37,5
DCT 310	513	102	117	174	205	475	2"G	37

TYPE	PROTECTION		1 PUMP CONTROL PANEL			2 PUMPS CONTROL PANEL		
	1 x 230 V	3 x 400 V	1 x 230 V	3 x 400 V	400 / 690 V	1 x 230 V	3 x 400 V	400 / 690 V
DC 160	PMC 15/35-15	PT 20-30-40/4.3-6.8	EQSM + 35µF	EQSMT 10		EQ2SM + 2x35µF	EQ2SMT 10	
DC 210	PMC 20/50-18	PT 20-30-40/4.3-6.8	EQSM + 50µF	EQSMT 10		EQ2SM + 2x50µF	EQ2SMT 10	
DCT 310		PT 40-50/5.7-9.1		EQSMT 10			EQ2SMT 10	
DCT 410		PT 55-75/8.6-13.5		EQSMT 10			EQ2SMT 10	
DCT 560		PT 55-75/8.6-13.5		EQSMT 10			EQ2SMT 10	
DCT 750		PT 100/12.5-16.5		EQSMT 10	QST 7		EQ2SMT 10	Q2ST 7
DCT-1000		PT 125-150/16-21		EQSMT 10	QST 10		EQ2SMT 10	Q2ST 10

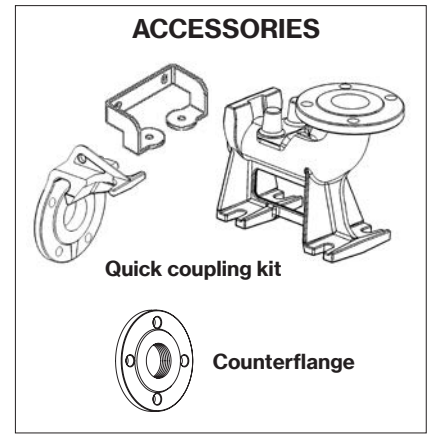
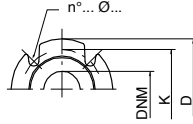
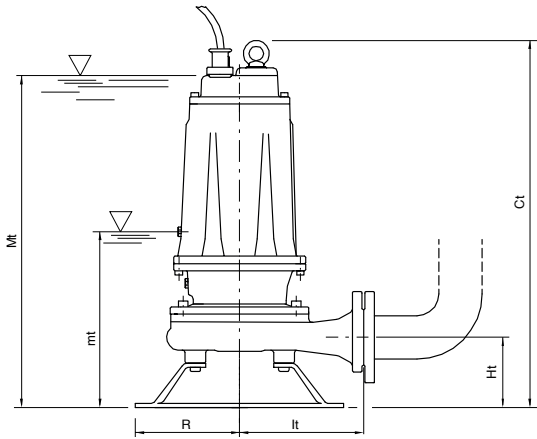

TYPE	DIMENSIONS (mm)								Kg
	Ct	Ht	R	lt	mt	Mt	DNM		
DCT 410	595	112	160	187	263	550	50	60,5	
DCT 560	595	112	160	187	263	550	50	63,5	
DCT 750	680	160	180	250	280	630	65	91	
DCT 1000	680	160	180	250	280	630	65	93,5	

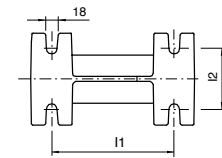
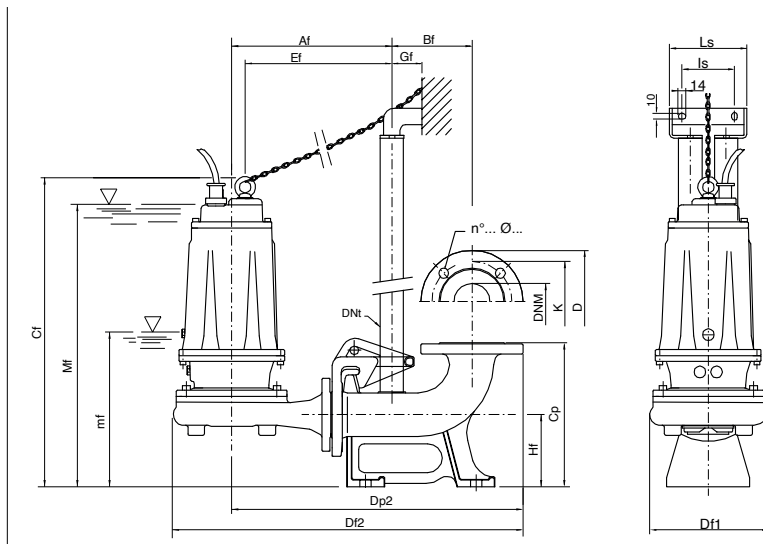

mt/mf: minimum working level
 Mt/Mf: minimum submergence level for continuous duty

TYPE	DIMENSIONS (mm)																		
	Af	Bf	Cf	Cp	Df1	Df2	Dp2	Dnt	Ef	Gf	Hf	l1	l2	l3	l4	l5	l6	l7	l8
DCT 410/P	300	145	614	260	237	654	535	1" 1/4	269	55	130	200	100	95	140	290	566	50	
DCT 560/P	300	145	614	260	237	654	535	1" 1/4	269	55	130	200	100	95	140	290	566	50	
DCT 750/P	331	145	656	260	279	701	569	1" 1/4	296	55	130	200	100	95	140	290	600	65	
DCT 1000/P	331	145	656	260	279	701	569	1" 1/4	296	55	130	200	100	95	140	290	600	65	

Flange UNI PN 10 (mm)			
DNM	K	D	n°... Ø...
50	125	165	4... 18...
65	145	185	4... 18...

