

1. HANDLING

Before installation, these installation and operating instructions must be read carefully.

The product must be lifted and handled with care.

2. APPLICATIONS

CB, CBI: Designed to handle clean, thin, non-aggressive water and non-explosive liquids, no solid particles.

HBI, HBN: Designed to handle clean, thin and non-explosive liquid without particles.

Also suitable for light industry applications

3. WORKING LIMITS

CB, CBI: —

- Max. operating pressure:
 - 0°C to +40°C → 10 bar, +41°C to +90°C → 6 bar.
 - Max. liquid temperature: 0°C ~ +90°C.
 - Max. ambient temperature: +55°C.
 - Min. inlet pressure:
- According to the NPSH curve + a safety margin of 0.5m.
- Max. inlet pressure: Limited by the max. operating pressure.

HBI, HBN: —

- Max. operating pressure: 10 bar.
 - Max. liquid temperature:
 - HBI-- 0°C ~ +90°C, HBN-- -15°C ~ +120°C.
 - Max. ambient temperature: +40°C.
 - Min. inlet pressure:
- According to the NPSH curve + a safety margin of 0.5m.
- Max. inlet pressure: Limited by the max. operating pressure.

4. INSTALLATION

- The pump may be installed as shown in Fig. 1.

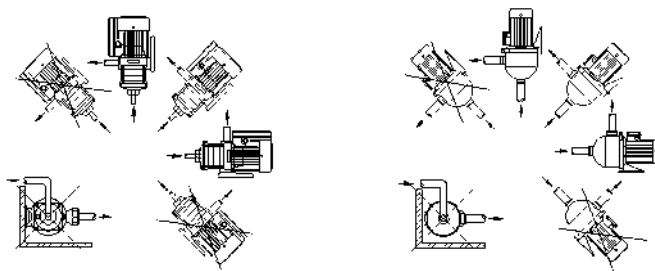

Fig. 1

- **Position of terminal box (Fig.2)**

The terminal box can be turned to three positions before the pump is installed.

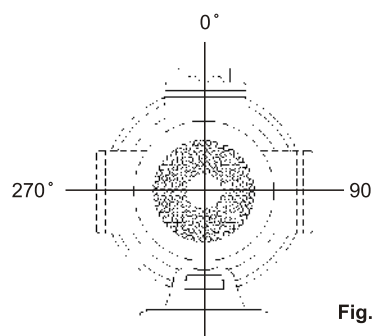

Fig. 2

- **Proper installation (Fig.3)**

A= Eccentric adapter

B= Positive lift

C= Good immersion

D= Long radius bends

E= Suction pipe diameter >= pump port diameter

F= Suction lift. Depends on pump and installation (*)

G= Pipes must not exert stress on pump but on independent supports

H= Foot valve.

(*) The suction lift is determined by liquid temperature, altitude, flow resistance and NPSH required by the pump.

Notes:

A general rule: When the suction pipe is longer than 10 meters or the suction lift is greater than 4 meters, the diameter of the suction pipe must be larger than that of the pump suction port.

- **Improper installation (Fig.3)**

1 = Tight bends: high flow resistance

2 = Insufficient immersion: air suction

3 = Negative lift: air pockets

4 = Pipe diameter < pump port diameter: high flow resistance.

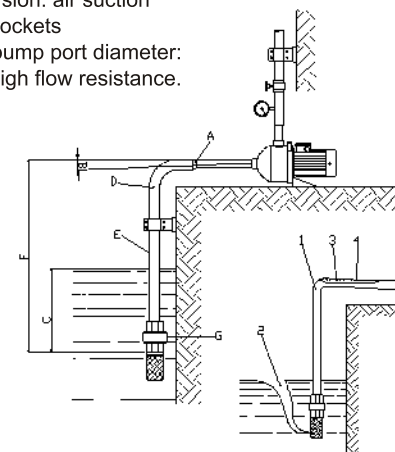

Fig.3

5. ELECTRICAL CONNECTION

- To connect (3 phase only), proceed as shown on the inside of the terminal board cover.
- Check the direction of rotation (3 phase motor only) Anticlockwise rotation.

6. Others

- **Priming (Fig.4)**

Before start up, to fill the pump body and suction pipe through the priming plug, bleeding off all the air

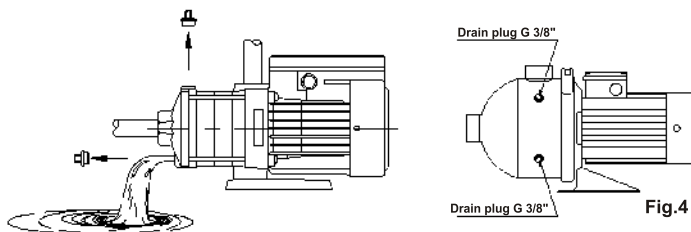

Fig.4

- **Maintenance**

No routine maintenance is required.

- **Frost protection**

Pumps which are not being used during periods of frost should be drained to avoid damage. Remove the priming and drain plugs and allow the pump to drain. Do not replace the plugs until the pump is to be used again.

7. TROUBLE SHOOTING

| Fault | Possible cause |
|--|--|
| 1. Pump does not run when the motor is turned on | Supply failure. |
| | Main contacts in motor starter are not making contact or the motor coil is faulty. |
| | Control circuit fuses have blown or are defective. |
| | Pump is blocked by foreign material Motor failure |
| 2. Pump runs but no water delivered | Pump is not primed |
| | Pump is blocked by foreign material |
| | Suction or discharge pipe blocked |
| | Foot valve or non-return valve is blocked |
| | Suction pipe is leaking |
| | Suction lift is too great Air in suction pipe or pump. |
| 3. Pump capacity is not constant or is reduced. | Pump is sucking air |
| | The pump, suction pipe or discharge pipe is partly blocked |
| | Inlet pressure too low |
| | Wrong direction of rotation (3 phase) |
| | Suction lift is too great Foot valve or non-return valve is partly blocked. |
| 4. Starter overload cut off immediately when the power is switched on. | Overload setting is too low. |
| | Loose or faulty cable connection |
| | One fuse is blown (3 phase) |
| | Pump is not free to run. |
| | Contacts in overload are faulty. |
| | The motor windings are defective. |
| | Low voltage (Especially at peak time). |

As STAIRS policy is one of constant improvement, we reserve the right to make specification changes without notice and without incurring liability.



STAIRS

Installation and operating manual

CB, CBI, HBI, HBN Series



STAIRS INDUSTRIAL CO. LTD.
 No. 3-8, Sanchial Tsun, Lutsao Hsiang,
 Chiayi Hsien, Taiwan, R.O.C.
 Tel: +886 5 3750488
 Fax: +886 5 3752330
 E-Mail: stairs@stairs.com.tw
 Web page: www.stairs.com.tw