

USER'S GUIDE

KD SERIE



2.2. - Dimensions.

Mod.	A	B	C	D	E	F	G	H	I	K	L	M	N	O	Weight kG
KD-3.000	570	370	80	16	88	410	290	240	260	115	169,5	28	31	30	64
KD-4.000	620	420	80	16	88	410	290	240	260	115	169,5	28	31	30	70
KD-5.000	675	475	80	16	88	410	290	240	260	115	169,5	28	31	30	75
KD-6.500	710	490	95	20	140	460	340	280	310	130	200	32	35	34	101
KD-8.000	770	550	95	20	140	460	340	280	310	130	200	32	35	34	111
KD-10.000	830	610	95	20	140	460	340	280	310	130	200	32	35	34	123
KD-12.000	895	675	95	20	140	460	340	280	310	130	200	32	35	34	135

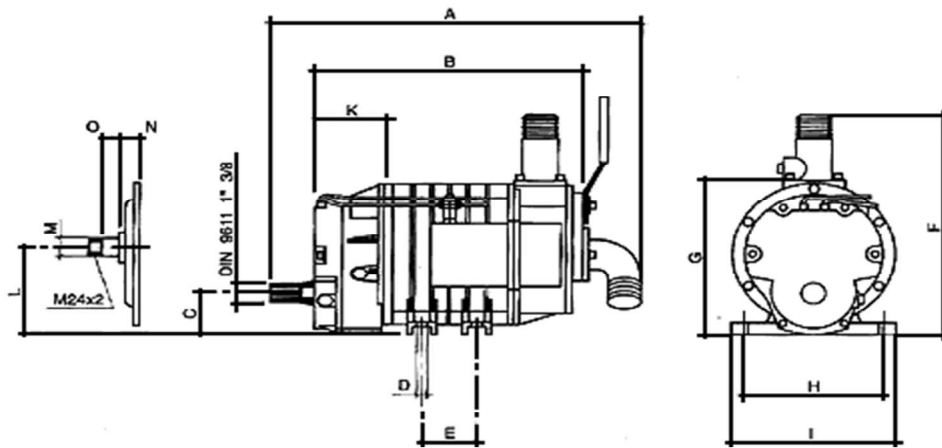

2.3. Other specifications.

Mod.	KD-3	KD-4	KD-5	KD-6.5	KD-8	KD-10	KD-12
Rpm.Max.	540	540	540	540 1.000	540 1.000	540 1.000	540 1.000
Max. vacuum (%)	90	90	90	90	90	90	90
Max. pressure (bar)	1,5	1,5	1,5	1,5	1,5	1,5	1,5
Weight (kG)	64	70	75	101	111	123	135
Noise level (dB)	85	86	86	87	87	87	88
Power consumption (kW)	8	10	12	15	18	22	25

Power consumption and noise level at maximum pressure