

Kiekis **Aprašymas**

1

SBA 3-45 AW

Atkreipkite dėmesį! Paveikslėlyje parodytas produktas gali skirtis nuo tikrojo

Produkto Nr.: [97896312](#)

Grundfos SBA 3-45 AW is an all-in-one submersible booster designed for pumping clean water for domestic use. The SBA is built on the proven SB platform and comes with an integrated control unit. This eliminates the need for an external pump controller in the house. It is silent when submerged and therefore a noiseless alternative to surface-mounted pumps. The pump is built from high quality composite and stainless steel materials that are resistant to corrosion.

The SBA 3-45 AW is equipped with a 15 m supply cable, and the maximum installation depth is 10 m below the water level, with a liquid temperature ranging from 0 °C to 40 °C.

The pump starts automatically when the pipe pressure falls below 2.2 bar.

The SBA 3-45 AW is ideal for operation in a well or ground tanks, as it easily prevents solid particles from entering the pump. The maximum particle size is 1 mm.

The pump features a float switch, which promises the user a convenient experience with automatic start/stop operation of the pump and provides dry running protection.

The pump is equipped with a side inlet/flexible hose with floating suction strainer.

The single-phase model is effectively protected against any accidental overload by built-in thermal protection.

The pump has built-in thermal protection, which immediately stops the pump if it overheats. Having cooled down, the pump automatically restarts when it reaches a normal temperature.

Skystis:

Siurbiamas skystis: Vanduo
Skysio temperatūros diapazonas: 0 .. 40 °C
Skysio temperatūra eksploatavimo metu: 20 °C
Tankis: 998.2 kg/m³

Techniniai duomenys:

Nominalus debitas: 2.83 m³/h
Nominalus slėgio aukštis: 30.1 m
Maks. dalelių dydis: 1 mm
Kreivės tikslumas: ISO9906:2012 3B
Return valve: YES
Start pressure: 2.4 bar
Nominalios pavaros apsisukas: 2800 rpm

Medžiagos:

Siurblio korpusas: Kompozitas
Darbaratis: Kompozitas

rengimas:

Aplinkos temperatūros intervalas: -10 .. 50 °C

Kiekis	Aprašymas
	vado jungties tipas: FLOATING STRAINER Siurblio išvadas: G 1" Maksimalus panardinimo gylis: 10 m Elektrotechniniai duomenys: Izoliacija: F Naudojama galia P1: 1.05 kW P2: 0.62 kW Elektros tinklo dažnis: 50 Hz Nominali tampa: 1 x 220-240 V Paleidimo srov : 12 A Cos fi: 0.94 Darbinis kondensatorius: 13 µF/450 V Korpuso klas (IEC 34-5): IP68 Kabelio ilgis: 15 m Kabelio tipas: H07RN-F 3G1 Kabelio kištuko tipas: SCHUKO Nominali srov : 4.8 A Kita: Neto mas : 9.83 kg Bruto mas : 10.6 kg Tiekimo t ris: 0.031 m ³ Danijos VVS Nr.: 391368045 Švedijos RSK Nr.: 5850423 Suomi : 4822548 Norvegijos NRF Nr.: 9041858 Sertifikatai: CE,VDE,WEEE

97896312 SBA 3-45 AW 50 Hz

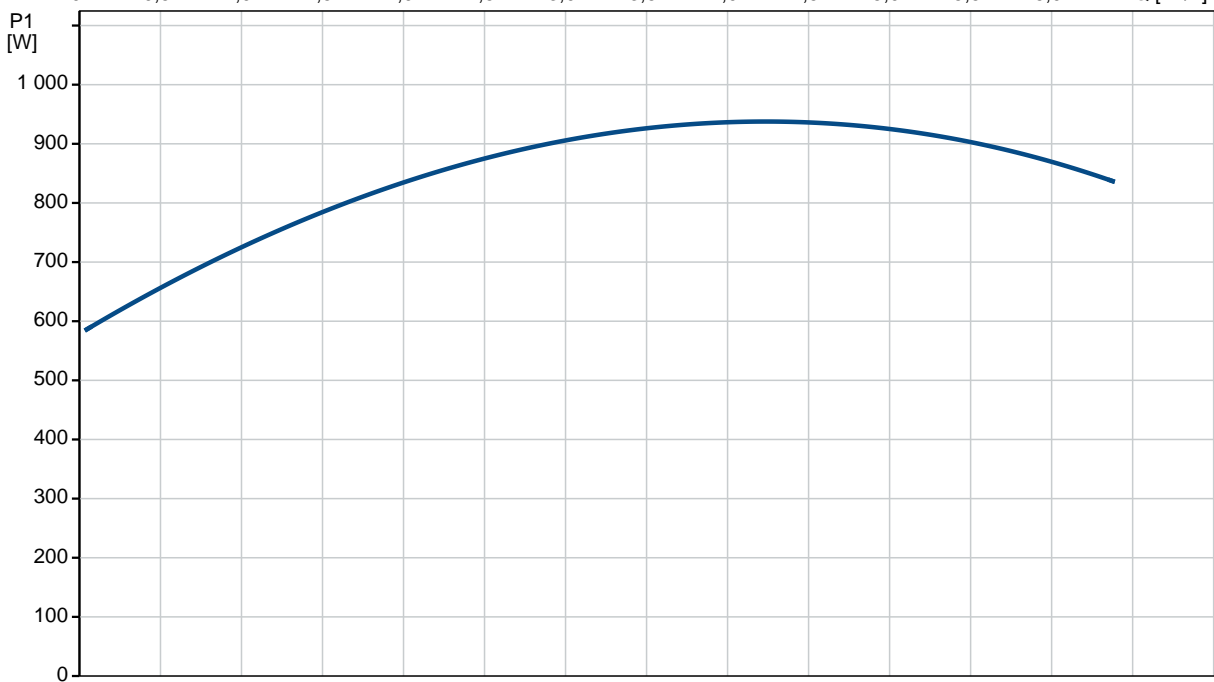
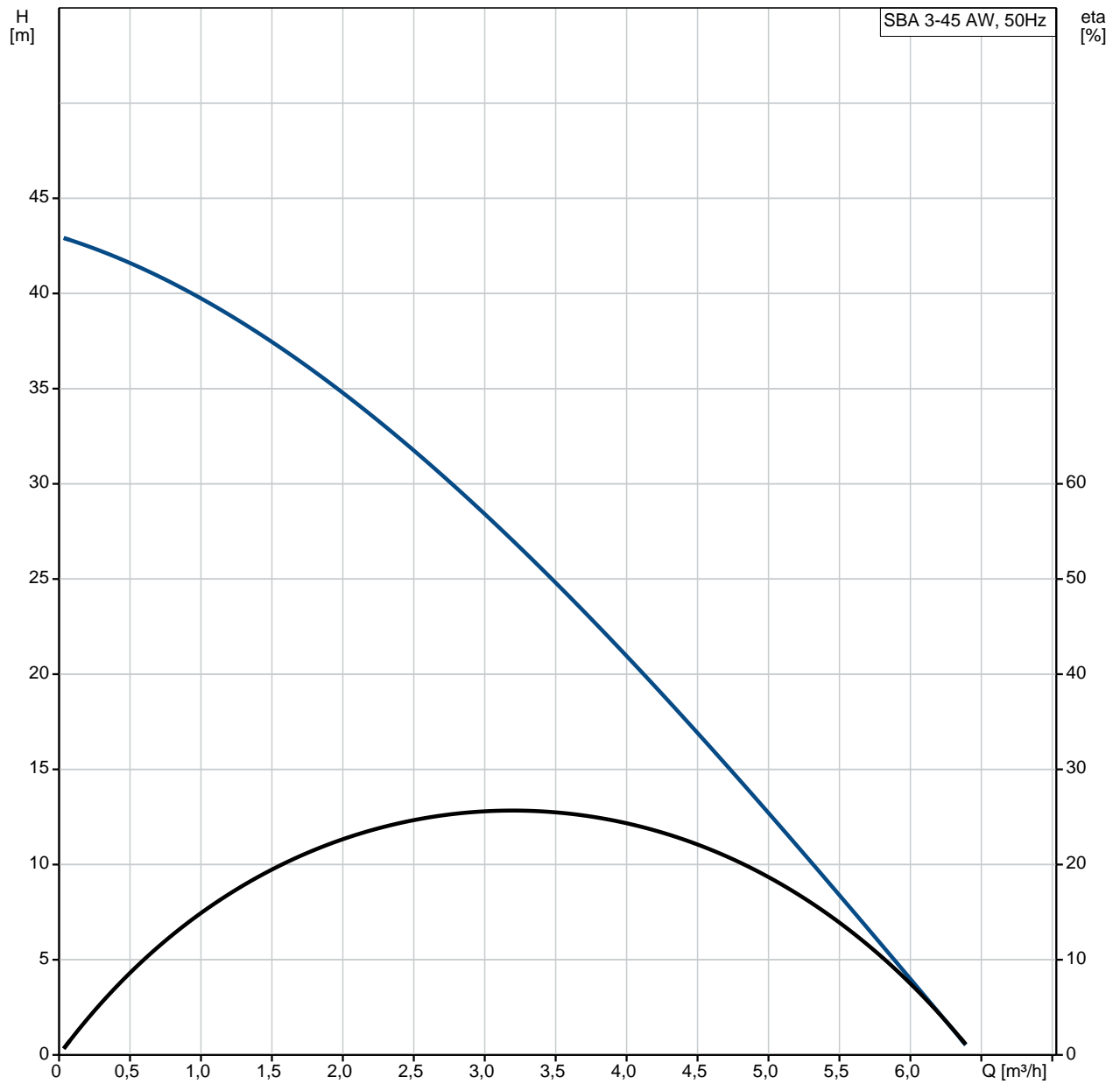

97896312 SBA 3-45 AW 50 Hz

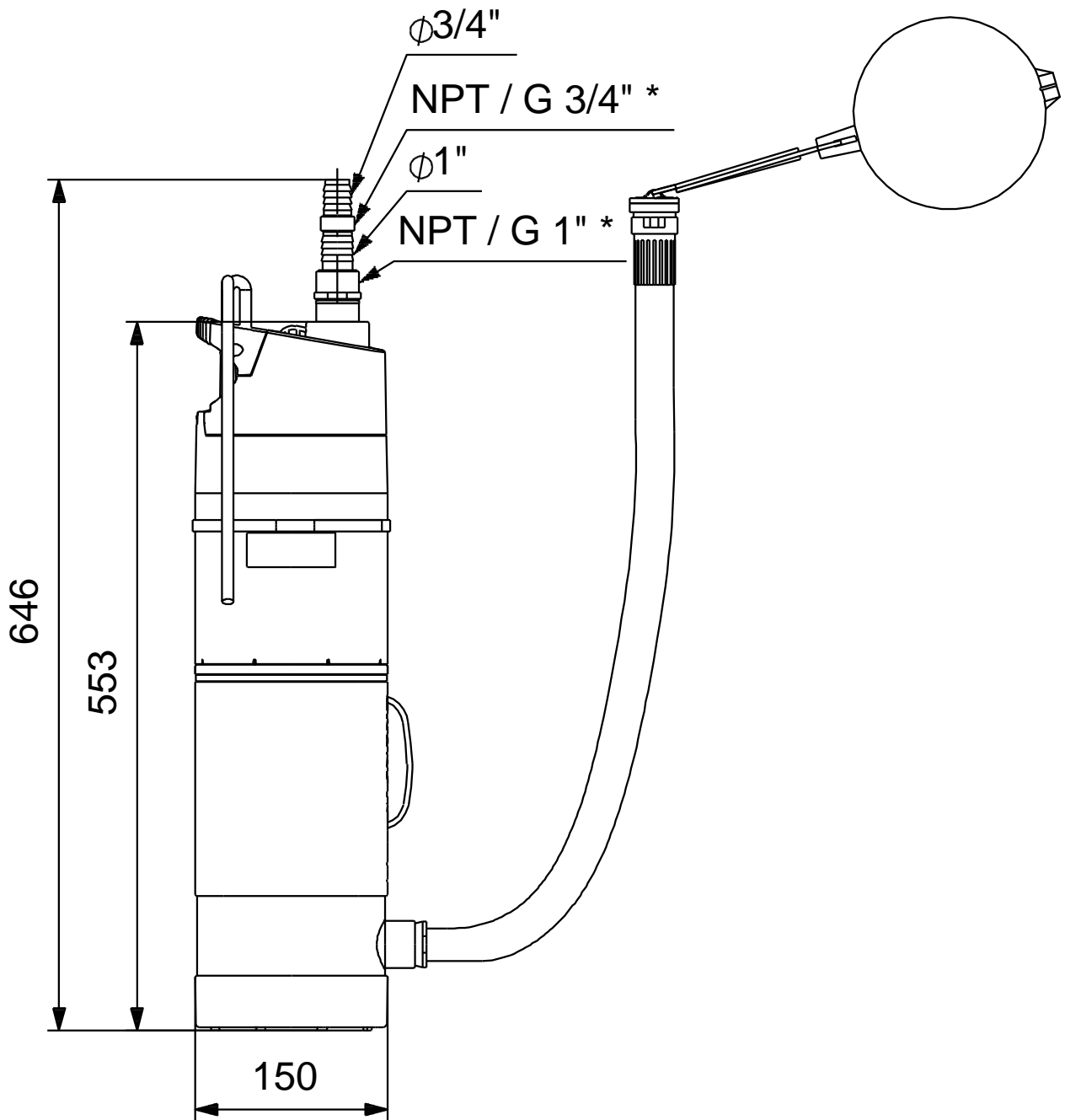

Atkreipkite dėmesį! Visi matmenys, jei nenurodyta kitaip, pateikti milimetrais.
Atsakomybės apribojimas: šiame supaprastintame matmenų brėžinyje neparodytos visos detalės.