

### Piede di accoppiamento rapido tipo B (completo di staffa guida tubi e sostegno di unione)

Automatic coupling foot Type B (guide rails, coupling support included)



#### Caratteristiche generali

- Flangiato
- Corpo in ghisa GG25
- Accoppiamento meccanico tra piede e flangia
- Passaggio libero integrale
- Corredato con flangia, staffa guida tubi e viteria inox
- Fischer e viti per l'installazione compresi

#### Main specifications

- Flanged
- Body made of GG25
- Mechanical fitting between coupling foot and coupling support
- Full free passage
- Guide rails, coupling support and stainless steel screw/ bolt included
- Fischer and screw for fixing included

#### Tipo - Type

B4 ingresso-inlet	DN65 PN6 mandata-delivery DN65 PN6
B4 ingresso-inlet	DN65 PN10 mandata-delivery DN65 PN10
B5 ingresso-inlet	DN80 PN16 mandata-delivery DN80 PN16
B6 ingresso-inlet	DN100 PN16 mandata-delivery DN100 PN16
B7 (basso-low) ingresso-inlet	DN150 PN16 mandata-delivery DN150 PN16
B8 (alto-high) ingresso-inlet	DN150 PN16 mandata-delivery DN150 PN16
B9 ingresso-inlet	DN200 PN10 mandata-delivery DN200 PN10

#### Dimensioni - Dimensions

	A	B	C	D	E	F	G	H	I	L	M	N	n° fori/holes
<b>B4 DN65 (PN6-PN10)</b>	151	235	373	136	301	140	1 1/4"	70	30	65	120	Ø14	4
<b>B5 DN80</b>	190	292	407	150	365	166	2"	80	41	100	130	Ø18	6
<b>B6 DN100</b>	250	356	492	205	402	203	2"	80	41	100	160	Ø24	6
<b>B7 (basso-low) DN150</b>	283	432	570	260	470	242	2"	80	41	100	180	Ø24	6
<b>B8 (alto-high) DN150</b>	283	432	570	422	630	242	2"	80	41	100	180	Ø24	6
<b>B9 DN200</b>	285	390	560	316	544	121	2"	80	41	100	240	Ø24	6

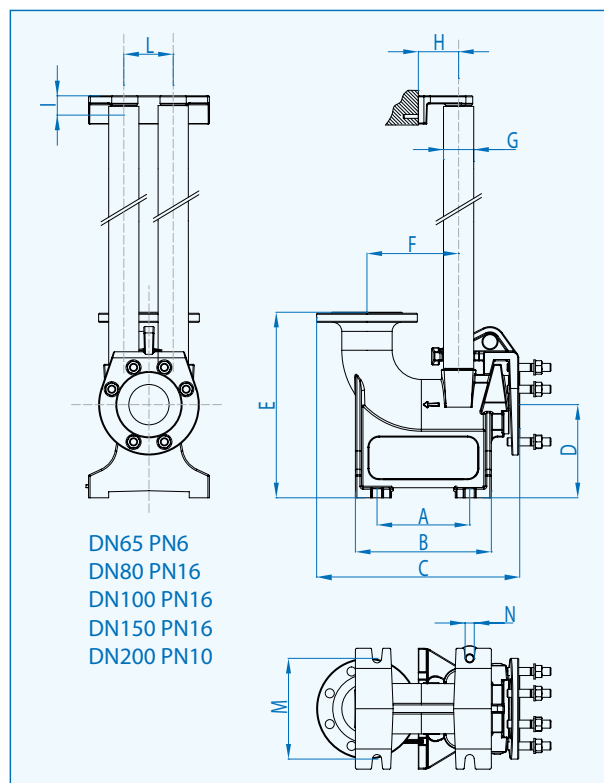

#### Dimensioni imballo - Packaging dimension

Tipo - Type	X mm	Y mm	Z mm	Kg
<b>B4 DN65</b>	400	210	330	22
<b>B5 DN80</b>	510	310	440	39
<b>B6 DN100</b>	510	310	440	53
<b>B7 (basso-low) DN150</b>	590	360	330	83
<b>B8 (alto-high) DN150</b>	-	-	-	101
<b>B9 DN200</b>	-	-	-	101,5