



Pompe da drenaggio con girante "Bicanale" per il pompaggio di acque cariche e liquidi con corpi in sospensione; ideali nelle applicazioni civili e domestiche.

Drainage pump with "Double-Channel" impeller for pumping charged waters and liquids with suspended solids; ideal for civil and household applications.

Bombas de drenaje con turbina "Bicanal" para bombear aguas cargadas y líquidos con cuerpos en suspensión; ideales en las aplicaciones civiles y domésticas.

Pompes de drainage avec turbine "Bicanal" pour le pompage d'eaux chargées et de liquides avec corps en suspension; idéales dans les applications civiles et domestiques.

**CARATTERISTICHE COSTRUTTIVE / CONSTRUCTION FEATURES
CARACTERÍSTICAS CONSTRUCTIVAS / CARACTÉRISTIQUES D'EXÉCUTION**

Corpo pompa Pump body Cuerpo bomba Corps de pompe	ghisa cast iron fundición fonte
Camicia, coperchio motore, base appoggio Shell, motor cover, base support Camisa, tapa motor, base apoyo Chemise, couvercle moteur, support de base	acciaio inox stainless steel acero inoxidable acier inox
Girante Impeller Rodete Turbine	acciaio inox stainless steel acero inoxidable acier inox
Tenuta meccanica Mechanical seal Sello mecánico Garniture mécanique	doppia tenuta con barriera d'olio: carburo di silicio lato pompa, ceramica-grafite lato motore double seal with oil barrier; silicon carbide on pump side, ceramic-graphite on motor side doble sello con cámara interpuesta: carburo de silicio lado bomba, cerámica-grafito lado motor double garniture avec film lubrifiant: carbure de silice côté pompe, céramique-graphite côté moteur
Albero motore Motor shaft Eje motor Arbre moteur	acciaio AISI 430 stainless steel AISI 430 acero AISI 430 acier AISI 430
Passaggio corpi solidi Passage of solids Paso de solidos Passage corps solides	Ø max 50 mm
Profondità di immersione Depth of immersion Profundidad inmersión Profondeur immersion	max 5 m
Temperatura del liquido Liquid temperature Temperatura del líquido Température du liquide	0 - 40 °C
Cavo Cable Cable Câble	H07 RNF, 10 m
G	galleggiante float switch flotador flotteur

MOTORE / MOTOR / MOTOR / MOTEUR

Motore 2 poli a induzione 2 pole induction motor Motor de 2 polos a inducción Moteur à induction à 2 pôles	3~ 230/400V-50Hz 1~ 230V-50Hz (con termoprotettore with thermal protection con protección térmica avec protection thermique)
Classe di isolamento Insulation class Clase de aislamiento Classe d'isolation	F
Grado di protezione Protection degree Grado de protección Protection	IP68



TYPE	TRUCK		CONTAINER	
	PALLET (cm)	N° pumps	PALLET (cm)	N° pumps
DB	80X120X160	51	80X120X160	51

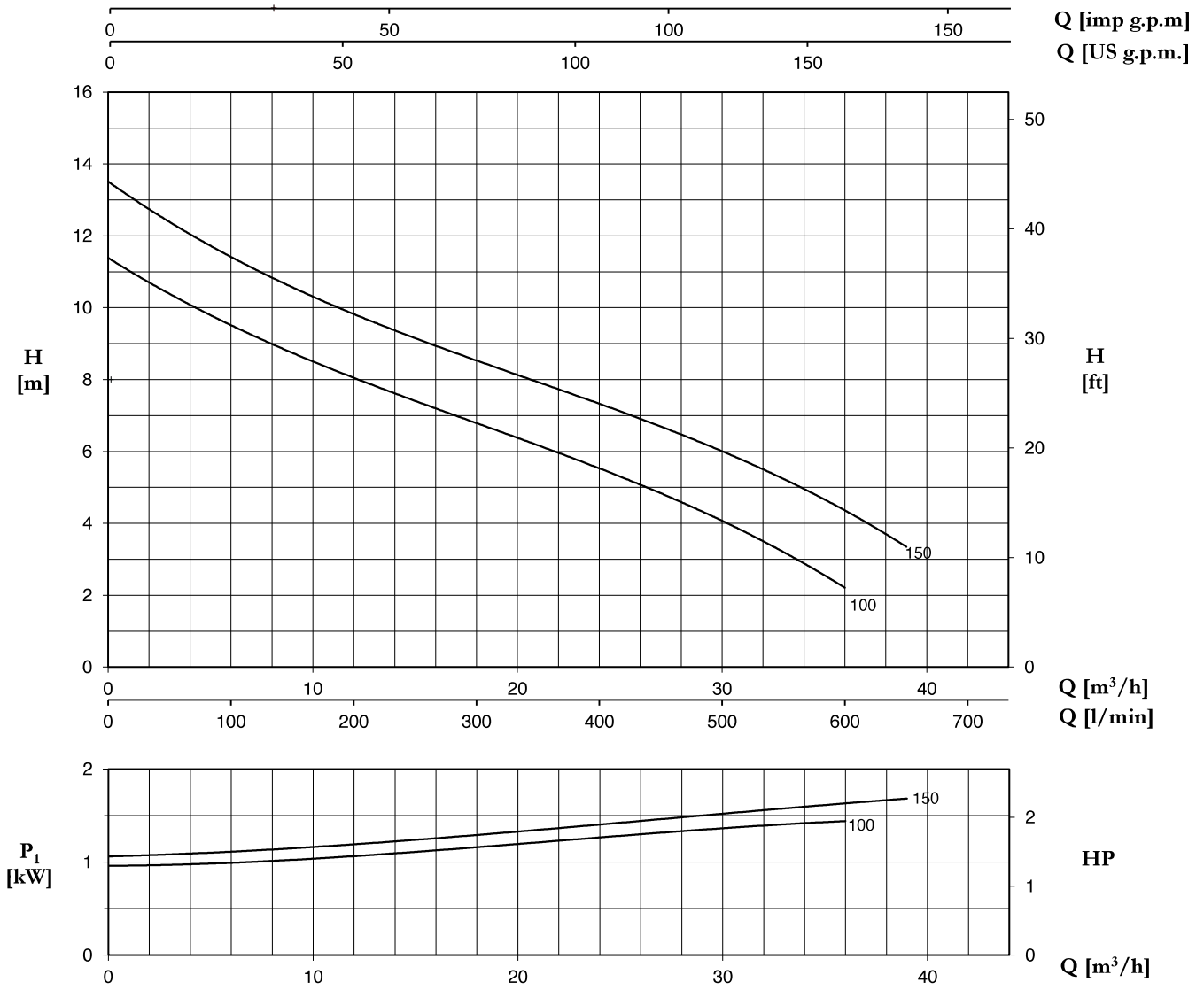

TYPE		W	AMPERE		Q (m³/h - l/min)							
1~	3~		1~	3~	0	6	12	18	24	30	36	39
					0	100	200	300	400	500	600	650
			1x230 V 50 Hz	3x400 V 50 Hz	H (m)							
DB 100 (G)	DBT 100	1350	5,9	2,8	11,4	9,5	8,0	6,8	5,6	4,0	2,2	-
DB 150 (G)	DBT 150	1700	8,0	3,0	13,6	11,5	9,8	8,5	7,3	6,0	4,3	3,4

E: massimo livello di svuotamento
 E: maximum emptying level
 E: máximo nivel de vaciado
 E: niveau maximum de vidange

Mt: livello minimo di funzionamento continuo
 Mt: lowest level for continuous duty
 Mt: nivel mínimo de funcionamiento continuo
 Mt: niveau minimum de fonctionnement continuu

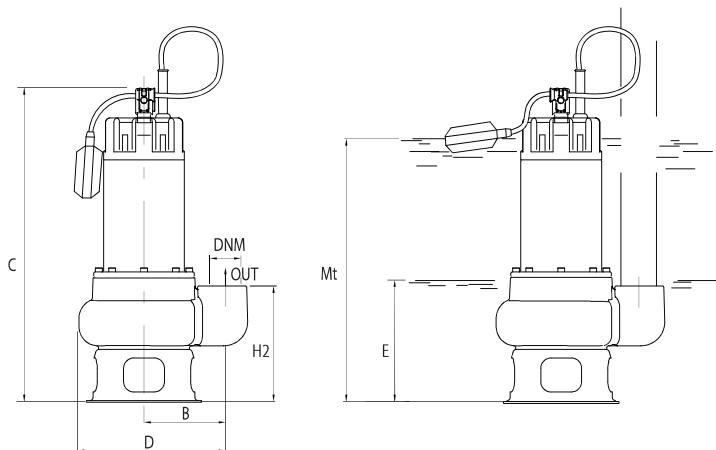

TYPE	DIMENSIONS (mm)										Kg
	B	C	D	E	H2	Mt	DNM	I	L	M	
DB 100 (G)	142,5	461	247,5	185	170	390	2" G	200	260	470	15
DB 150 (G)	142,5	461	247,5	185	170	390	2" G	200	260	470	17