



- 01 -

- 02 -

- 03 -

- 04 -

- 05 -

- 06 -

- 07 -

Pumps

• End Suction Centrifugal Pump

LEO LEO GROUP PUMP(ZHEJIANG) CO.,LTD. (Stock code: 002131)

2016 v1.1

www.leogroup.cn

LEO GROUP PUMP(ZHEJIANG) CO.,LTD.



www.leogroup.cn

No.1, 3rd Street, East Industry Center, Wenling, Zhejiang, China, 317500
Tel: +86-576-8998 6360 Fax: +86-576-8998 9898 E-mail: export@leogroup.cn www.leogroup.cn

HISTORY

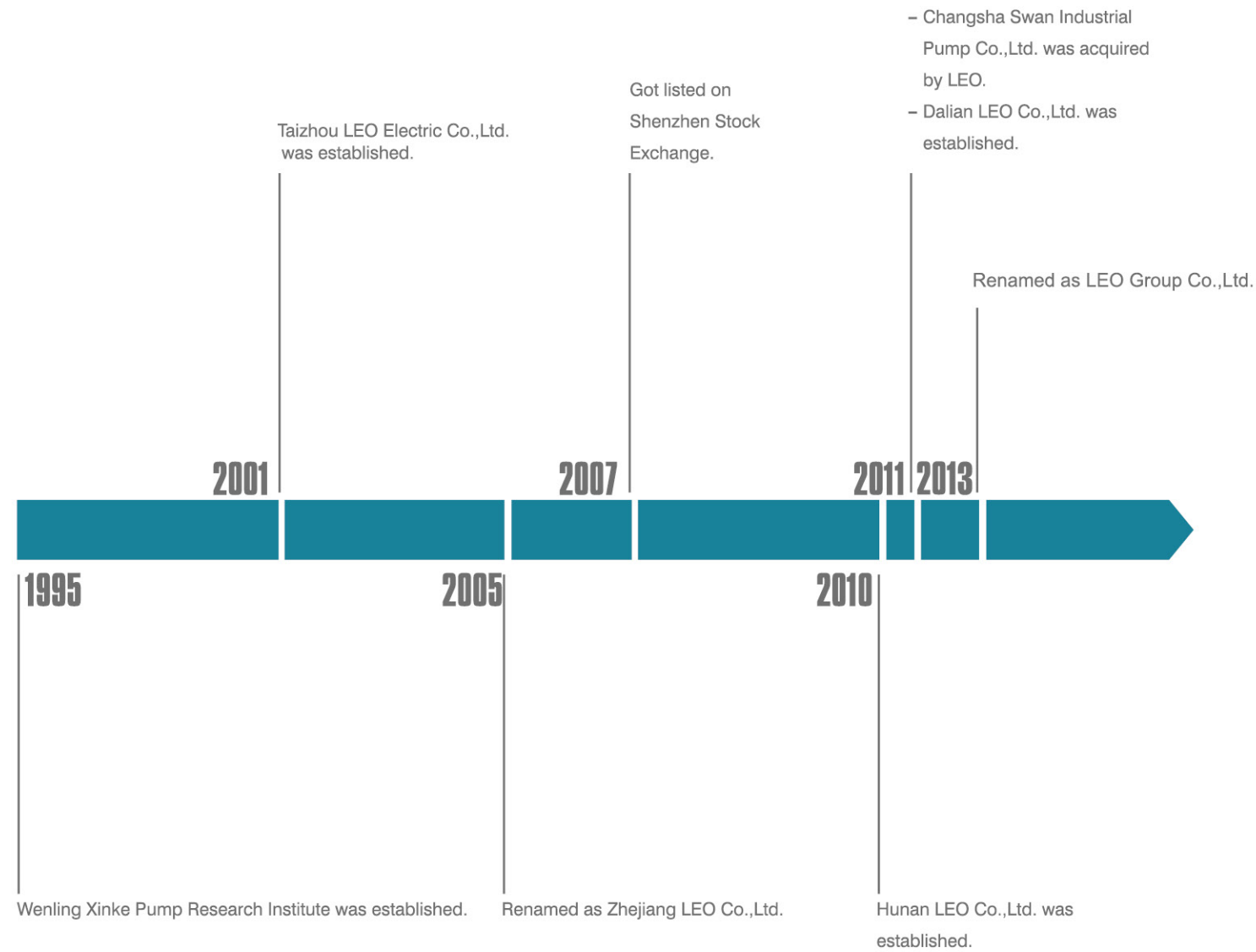

TO KNOW LEO

LEO Group (got listed in Shenzhen Stock Exchange with stock code 002131) is a national high-tech enterprise engaged in R&D, design , manufacture, sales and service of all series pump. LEO is the first listed company in Chinese pump industry, one of the drafters of pump industry standard and the vice president of drainage and irrigation machinery branch of China Agricultural machinery industry association as well. It is mentionable that LEO has the only state-authorized technical center in this industry.

Our products have been sold to over 120 countries and regions, such as Europe, North America, Central &South America, Southeast Asia, Middle East, Africa, Oceania ,etc., which play a crucial role in water conservancy , water resources, electric power construction, petrochemical industry, mining, metallurgy, fire-fighting, HVAC(Heating, Ventilation and Air Conditioning), agricultural irrigation, civil water supply and drainage, etc.

LEO has currently two industrial groups respectively for industrial and civilian applications. With five manufacturing bases in Wenling of Zhejiang, Xiangtan of Hunan, Changsha of Hunan, Wuxi of Jiangsu and Dalian of Liaoning, LEO possesses a solid foundation to become a world-class pump and system solution provider rapidly.

With over 70 years' professional technology, LEO will continue her consistent creativity and development ability in each pump for human's health.



NUMEROUS MEMBERS, ONE FAMILY

Based on market segment, LEO's pump business is divided into 5 fields, namely water conservancy & water resources, power station, petrochemical industry, mining & metallurgical industry and civilian applications. For each field there's a professional manufacturing base with relevant professional sales teams. Four subsidiary companies – Wuxi LEO Xi Pump, Changsha LEO Swan Pump, Dalian LEO Huaneng Pump and Hunan LEO Pump are all well-known industrial pump manufacturers in their own fields. With over 70 years' industrial pump manufacturing experience and extraordinary comprehensive strength, LEO becomes a leading company among all industrial pump manufacturers in China.



Pump Manufacturing Base for Domestic and Commercial Applications (Wenling City, Zhejiang Province)

It is the core base for R&D, manufacturing, sales and service of domestic and commercial pumps for family water supply, pipeline boosting, garden and field irrigation, HVAC, etc.

The leading products include peripheral pump, jet pump, centrifugal pump, garden submersible pump, fountain pump, pool pump, domestic lifting station, gasoline engine pump, diesel engine pump, submersible pump, submersible borehole pump, submersible sewage pump, stainless steel vertical multistage pump, etc.

The product range covers 15 series with over 2,000 specifications, which are well sold in more than 120 countries and regions. The base has established steady cooperative relationships with world-class pump manufacturers, importers, dealers and hypermarkets.



Pump Manufacturing Base for General Industrial Pumps (Xiangtan City, Hunan Province)

It is the most important base for industrial pumps.

The products are mainly used in mine, metallurgy, coal washing, FGD, municipal water, etc.

A world-class pump testing center with testing power up to 12,500 kW realizes high precision tests for real pumps which are used for power station, water conservancy and water resources, petrochemical industry, mining and metallurgical industry.



Pump Manufacturing Base for Water Conservancy & Water Resources (Wuxi City, Jiangsu Province)

This base grew out of Wuxi Xi Pump Manufacturing Co., Ltd, a well-known manufacturer for water conservancy.

The base is specialized in production of large and medium-sized pumps for urban water supply and drainage, field irrigation, water conservancy projects and large water diversion projects. The main products cover 8 series with 995 specifications.

With great honor, the model 300HW-8 mixed-flow pump won the first national quality award of Chinese pump industry. As a main supplier, the base provides large pumps for South-to-North Water Diversion Project, a national key project.



Pump Manufacturing Base for Petrochemical Industry (Dalian City, Liaoning Province)

The predecessor of this base is Dalian Huaneng Corrosion-Resistant Pump Works, who's a well-known pump manufacturer in petrochemical industry.

The base is specialized in production of petrochemical pumps for the upstream industry of oil and gas (including exploration, exploitation and storage) and downstream industry of petrochemicals (including crude oil refinery, heavy chemical industry, fine chemistry and coal chemical industry).

The base focuses on design and manufacture of 30 series (OH, BB, VS, etc.) of petrochemical pumps with over 3,000 specifications, which are in accordance with API and ISO standard. The production of large crude oil long distance pipeline pump (BB1 and BB2) and HTHP overloaded pump (BB3 and BB4) is available. LNG cryo-pump is already in development.

The base is Class A supplier of CNPC and qualified sub supplier of Shenhua Group.

Applications

- Water supply systems
- Pressure boosting
- Heating systems for commercial buildings and district heating
- Cooling plants for industrial processing and air-conditioning units
- General transport for industrial processes
- Fire fighting system

Identification Codes

LEP 50-32-130 H(G)/139

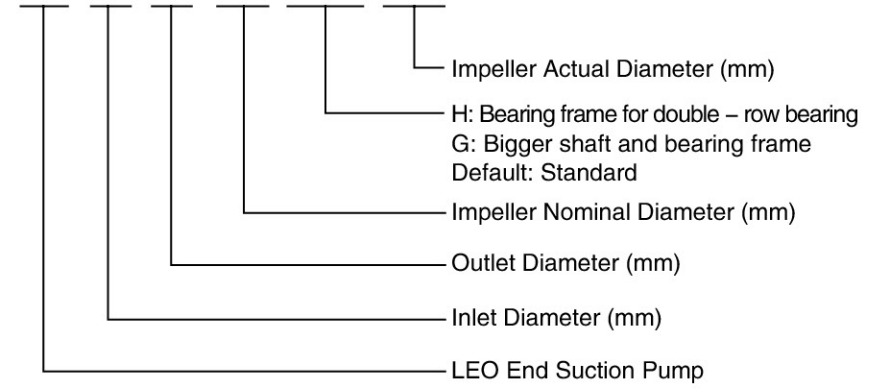

Working Conditions

- Pump design complies to BS EN 733/DIN 24255 standard
- Conveying medium: Low viscosity, non-flammable and non-explosive liquids not containing solid particles or fibers
- Speed: 1450/2900 rpm at 50 Hz, 1750/3500 rpm at 60 Hz
- Flow range: 0.5 - 440 l/s
- Head range: 2 - 152 m
- Max. liquid temperature: 105°C
- Liquid pH value: 4 - 10
- Max. operation pressure: 10 bar, 16 bar on request

Design & Structure

Design	Performance and dimensions referring to the European standard BS EN733/DIN24255
Structure	Horizontal, Axial End-Suction, Single-Stage, Single-Suction, Volute Casing, Back pull-out
DN(mm)	Inlet: 50-350 Outlet: 32-300
Flange	ISO7005.2 ; DIN2501 PN16 ; GB/T17241.6 PN1.6

Materials Table

No.	Part	Material
1	Pump casing	Cast Iron Ductile Iron 304/316
2	Impeller nut	
3	Wear ring	
4	Impeller	Brass/Bronze Cast Iron 304/316
5	Casing cover	
6	Shaft spacer	
7	Mechanical seal	
8	Seal cover	
9	Rubber slinger	
10	Bearing frame	
11	Shaft	304/316/1045

No.	Part	Material
12	Bearing	
13	Bearing cover	
14	Support foot	
15	Packing sleeve	Bronze
16	Packing seal cage	
17	Gland packing	
18	Gland cover	
19	Casing gasket	
20	Nut	
21	Nut	
22	Nut	

No.	Part	Material
23	Key	
24	Key	
25	Bolt	
26	Oil nipple	
27	Oil seal	
28	Nut	
29	Washer	
30	Washer	
31	Oil scale	
32	Oil cover	
33	Bearing Cover Gasket	

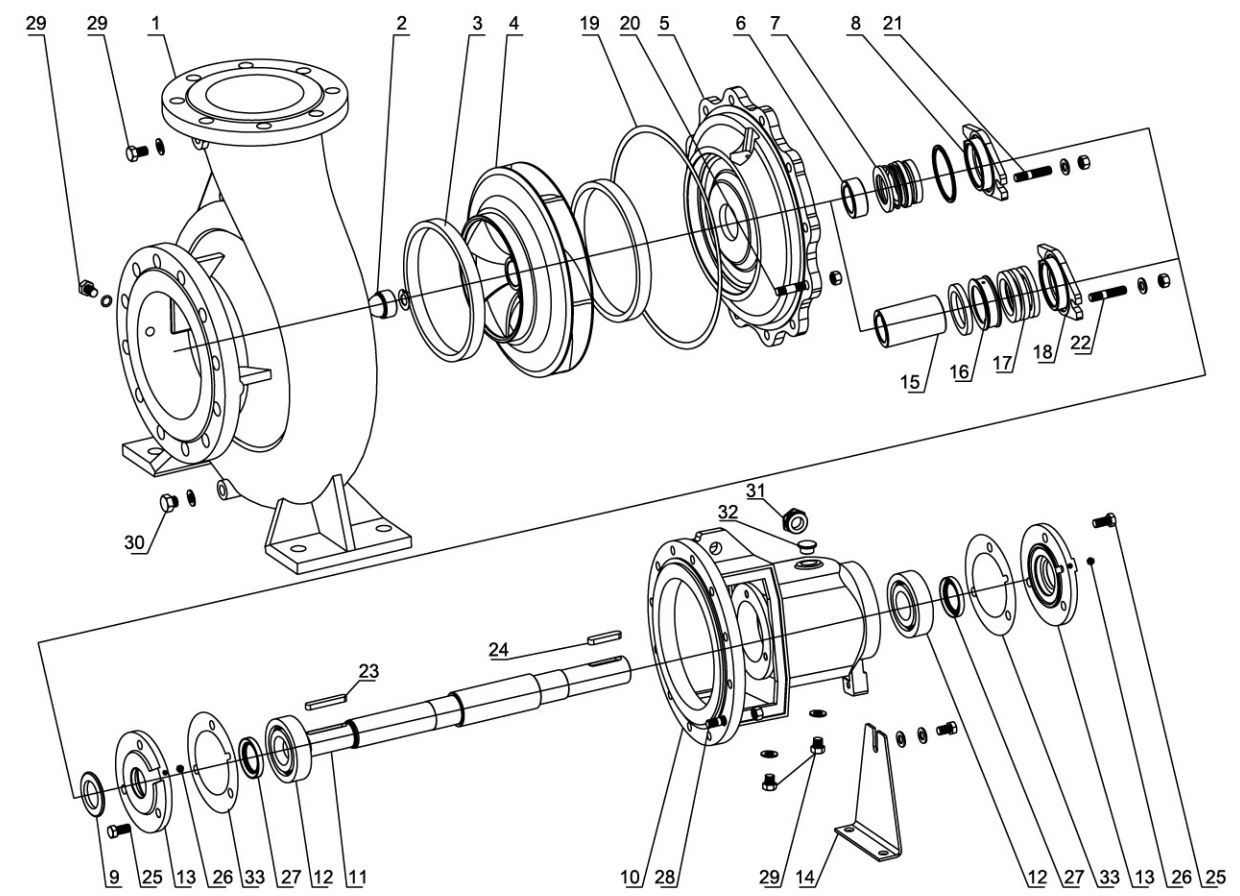

Characteristic Curves

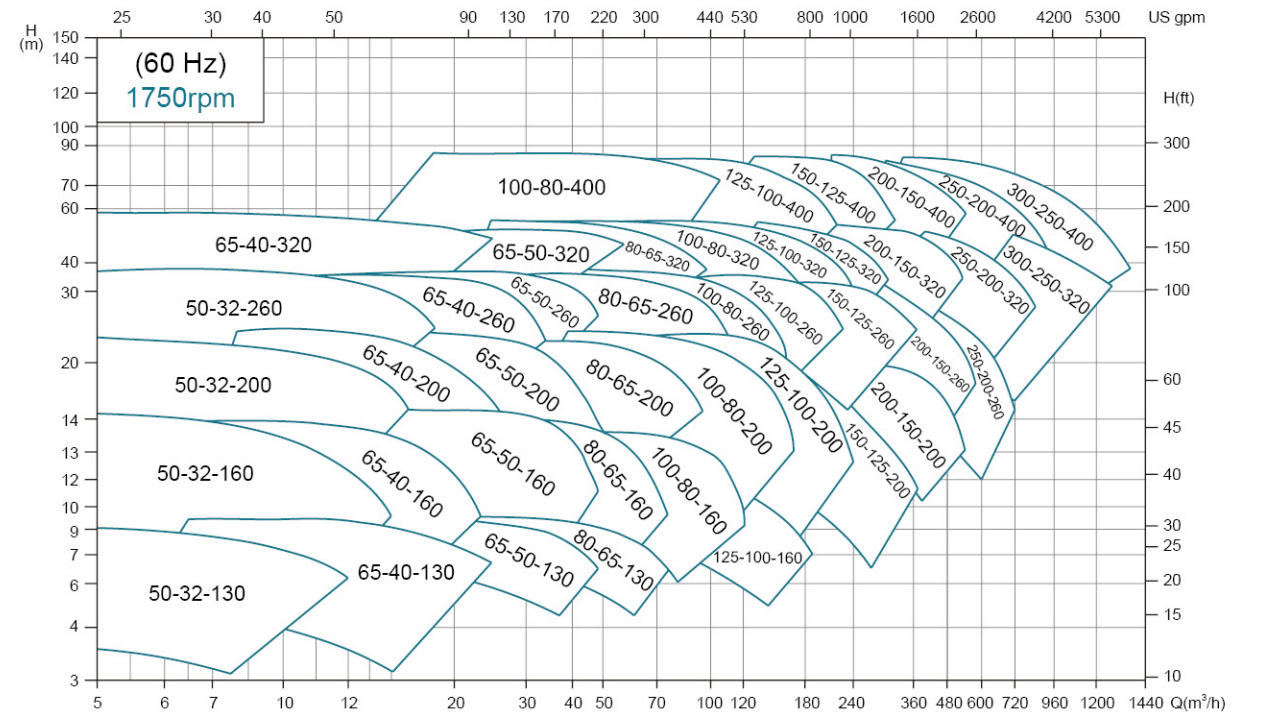
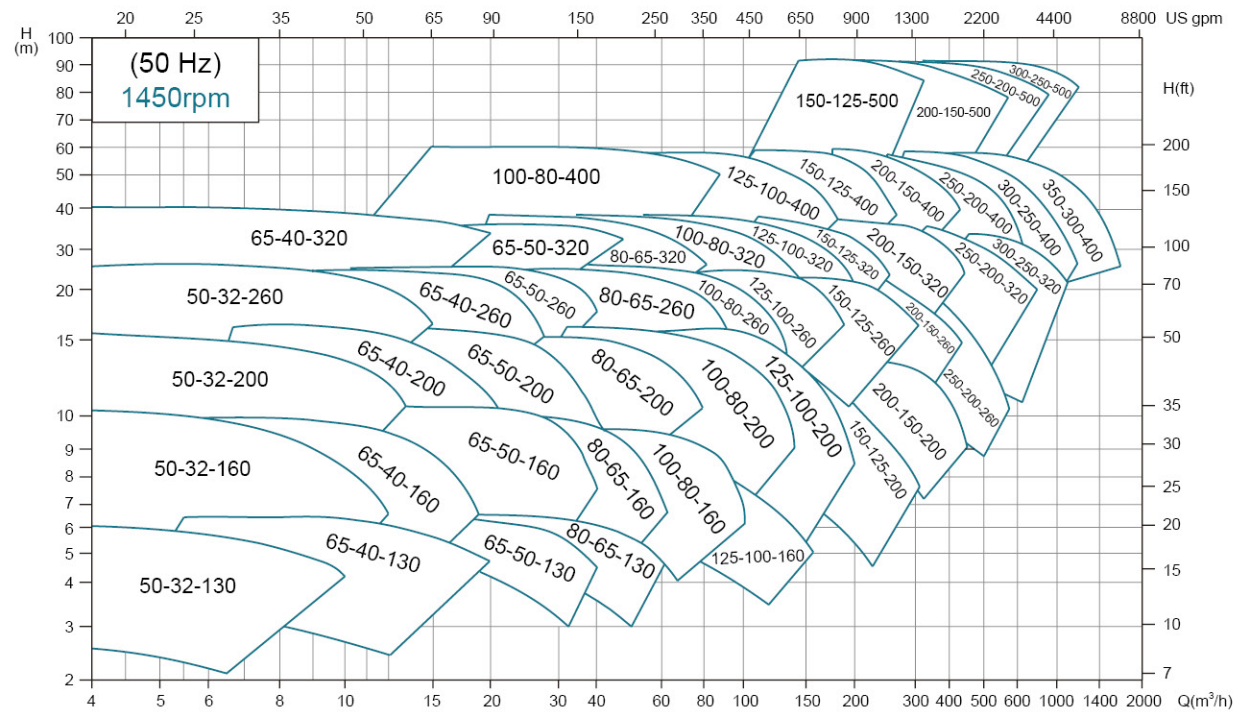
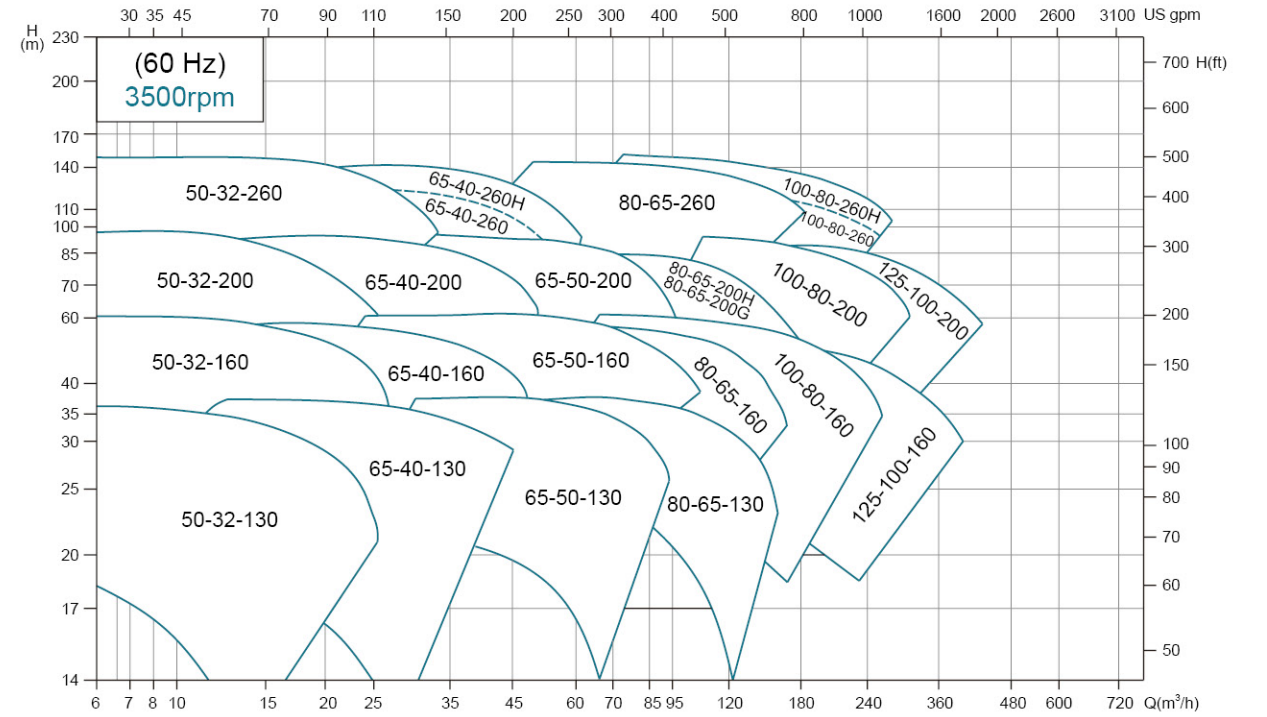
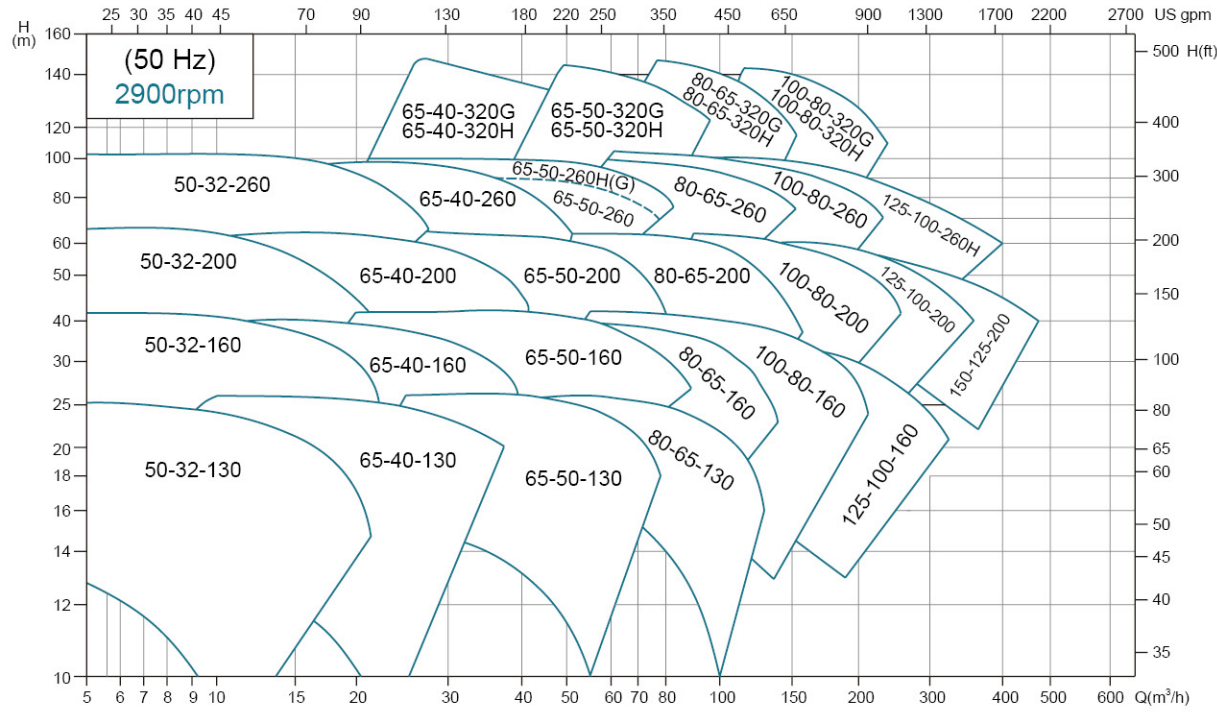

Installation Dimensions

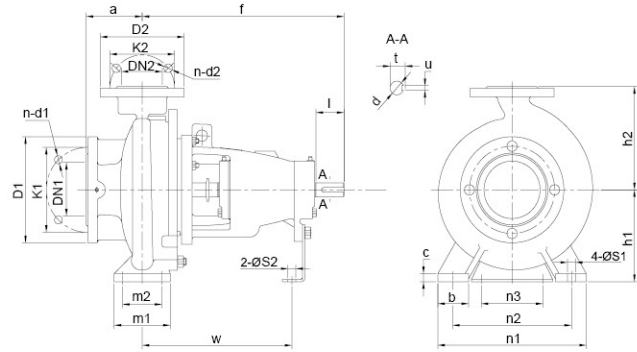

Model	Bearing ID (mm)	DN2	DN1	a	f	h1	h2	b	c	n3	m1	m2	n1	n2	S1	S2	w	d	l	t	u	Weight (Kg)			
LEP50-32-130	25	32	50	80	360	112	140	50	14	100	100	70	190	140	14	14							29		
LEP50-32-160						132	160																35		
LEP50-32-200						160	180																47		
LEP50-32-260	25	40	80	360	180	225	65	14	100	100	70	240	190	14	14								58		
LEP65-40-130					112	140	31																		
LEP65-40-160					132	160	34																		
LEP65-40-200	35	40	100	360	160	180	65	14	110	100	70	240	190	14	14								45		
LEP65-40-260(H)					180	225																	61		
LEP65-40-320					200	250																	94		
LEP65-40-320(H)	45	65	125	470	200	250	65	14	110	125	95	345	280	14	14								107		
LEP65-40-320G					526	200																	250	105	
LEP65-50-130					25	50																	100	360	132
LEP65-50-160	160	180	39																						
LEP65-50-200	160	200	49																						
LEP65-50-260(H)	35	50	100	360	180	225	65	14	100	125	95	320	250	14	14								68		
LEP65-50-260G					180	225																	65		
LEP65-50-320(H)					180	225																	113		
LEP65-50-320G	45	50	65	125	526	225	280	18	14	125	95	345	280	14	14								105		
LEP80-65-130																							160	180	41
LEP80-65-160																							160	200	47
LEP80-65-200(H)	25	65	80	100	360	160	200	65	14	125	95	280	212	14	14								55		
LEP80-65-200G						180	225																55		
LEP80-65-260						180	200																57		
LEP80-65-260(H)	35	65	80	100	470	200	250	80	14	160	120	360	280	14	14								87		
LEP80-65-320(H)						225	280																110		
LEP80-65-320G						225	280																120		
LEP100-80-160	25	80	100	125	530	180	225	65	14	125	95	320	250	14	14								53		
LEP100-80-200						180	250																76		
LEP100-80-260(H)						180	250																95		
LEP100-80-320(H)	35	80	100	125	530	200	280	80	14	110	120	400	315	14	14								118		
LEP100-80-320G						250	315																118		
LEP100-80-400						250	315																130		
LEP125-100-160	35	100	125	140	530	200	250	80	14	110	120	440	340	14	14								87		
LEP125-100-200						200	280																84		
LEP125-100-260(H)						225	280																102		
LEP125-100-320	45	100	125	140	530	250	315	80	14	110	120	400	315	14	14								118		
LEP125-100-400						250	315																118		
LEP150-125-200						250	315																117		
LEP150-125-260	35	125	150	160	530	280	355	18	14	110	120	400	315	14	14								117		
LEP150-125-320						280	355																155		
LEP150-125-400						280	355																178		
LEP150-125-500	55	150	200	160	670	315	400	100	18	110	150	550	450	14	14								300		
LEP200-150-200						315	400																207		
LEP200-150-260						315	400																219		
LEP200-150-320	45	150	200	160	670	280	400	100	18	110	150	450	350	14	14								170		
LEP200-150-400						280	400																207		
LEP200-150-500						280	400																219		
LEP250-200-260	55	200	250	180	670	315	450	120	20	110	170	600	480	14	14								286		
LEP250-200-320						315	480																286		
LEP250-200-400						315	480																328		
LEP250-200-500	65	200	250	200	720	425	560	100	22	140	200	150	660	560	14	14							450		
LEP300-250-320						691	355																366		
LEP300-250-400						682	400																396		
LEP300-250-500	65	250	300	200	720	450	670	120	32	140	240	190	750	650	14	14							550		
LEP350-300-400						682	400																396		
LEP350-300-500						682	400																550		

(ISO7005.2 DIN2501 PN16 GB/T17241.6 PN1.6)

DN1/DN2	32	40	50	65	80	100	125	150	200	250	300	350	400
D1/D2	140	150	165	185	200	220	250	285	340	405	460	520	580
K1/K2	100	110	125	145	160	180	210	240	295	355	410	470	525
n-d1/n-d2	4-φ18	4-φ18	4-φ18	4-φ18	8-φ18	8-φ18	8-φ18	8-φ22	12-φ22	12-φ26	12-φ26	16-φ26	16-φ30

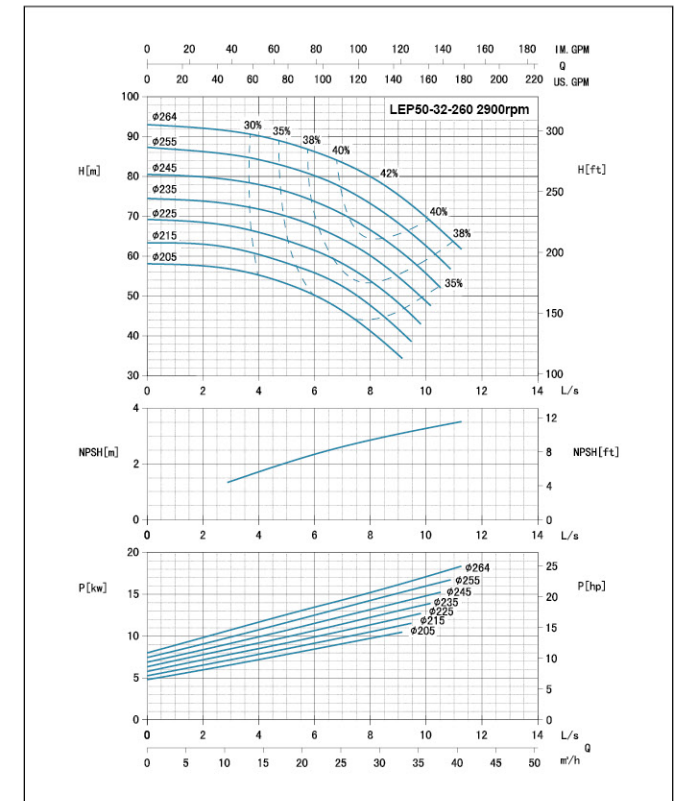
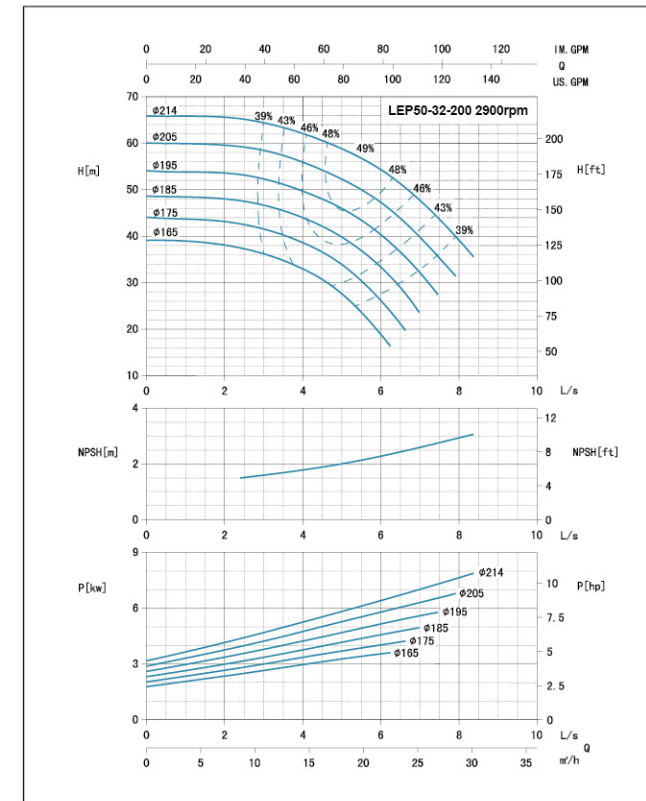
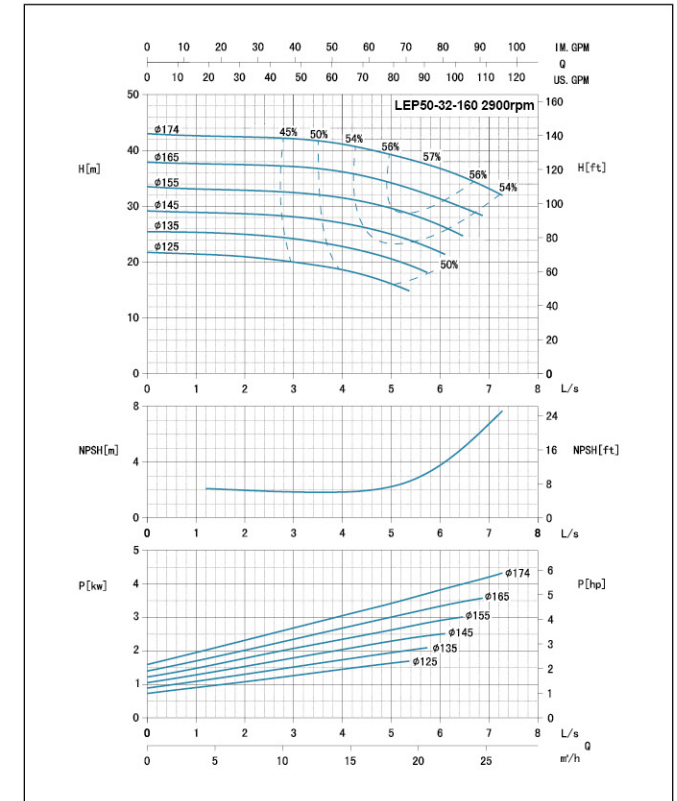
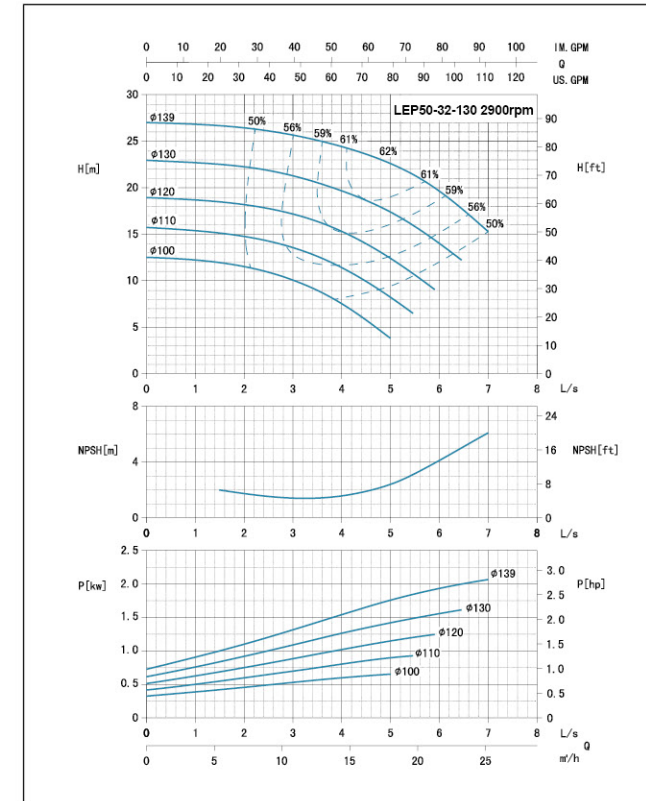

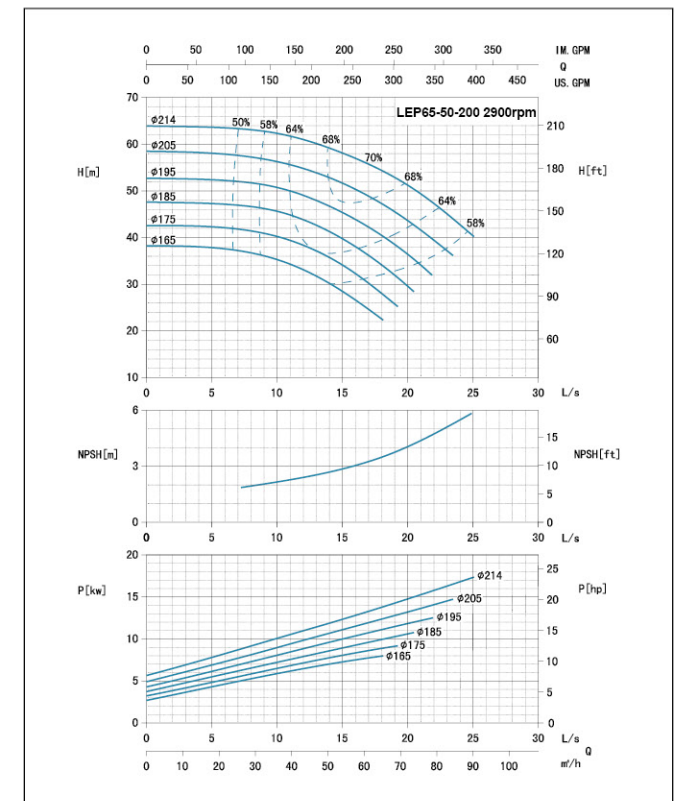
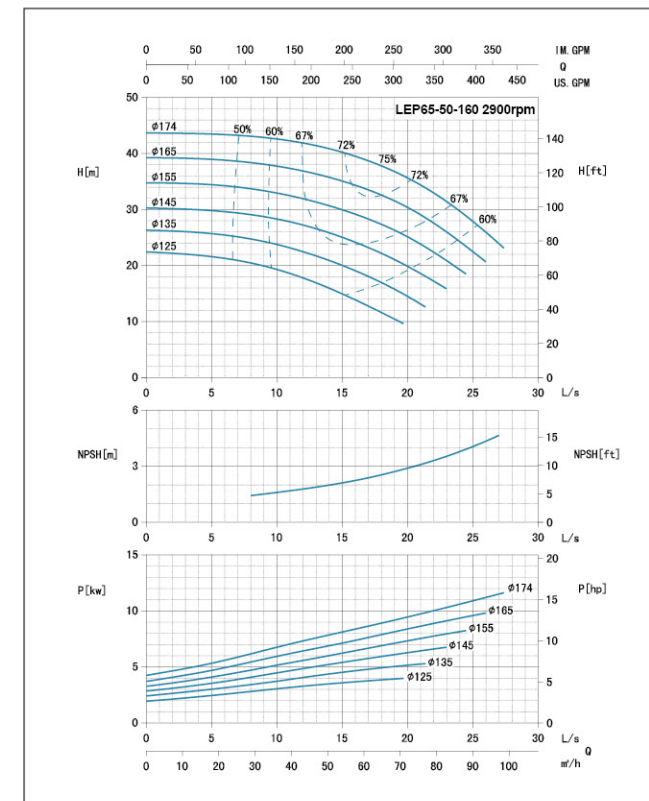
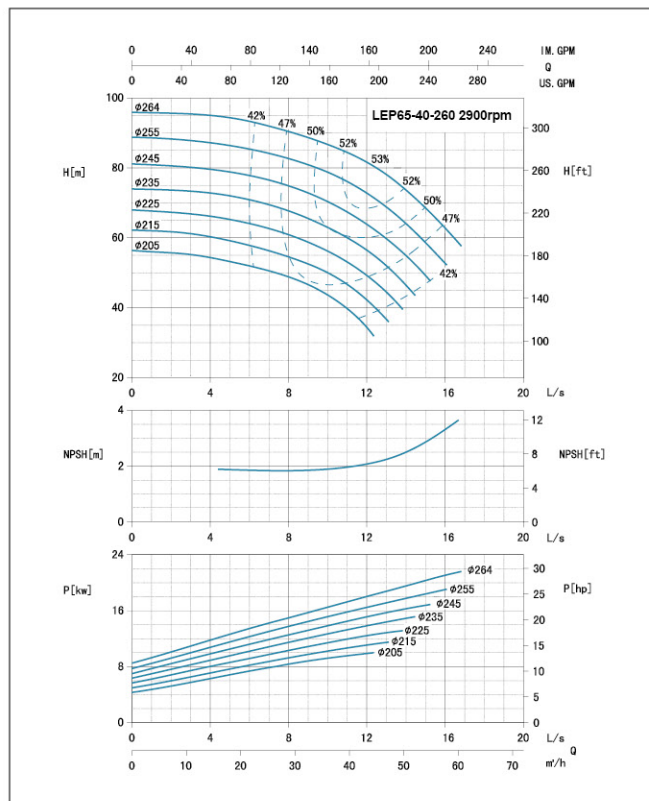
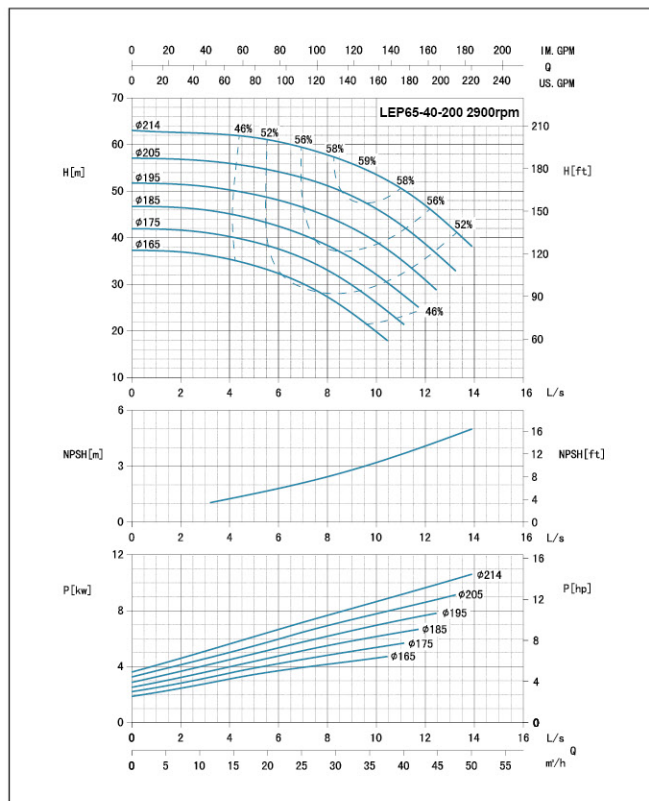
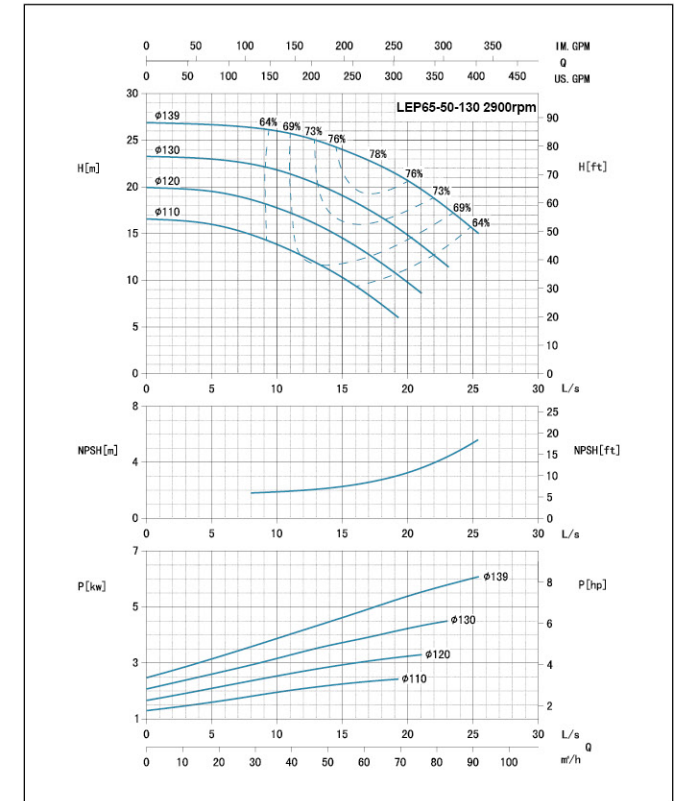
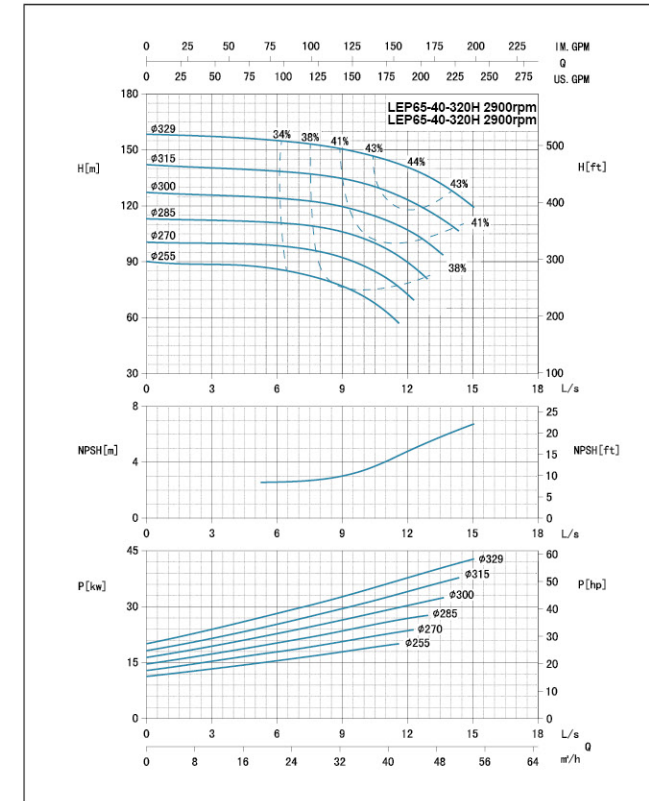
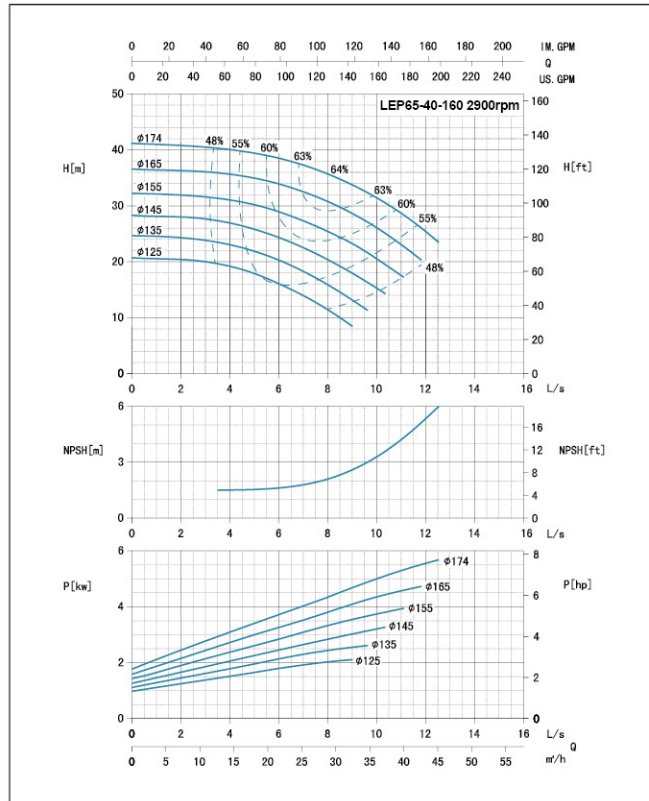
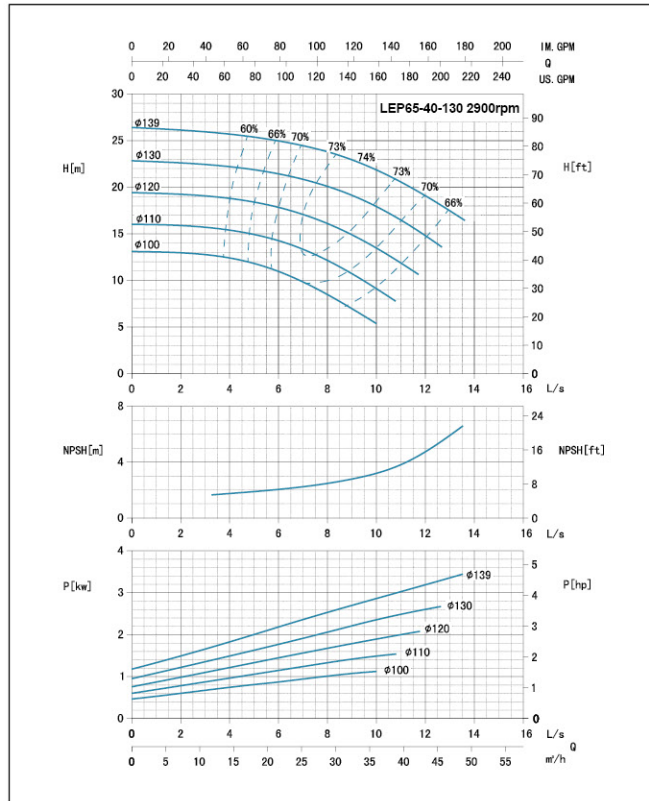

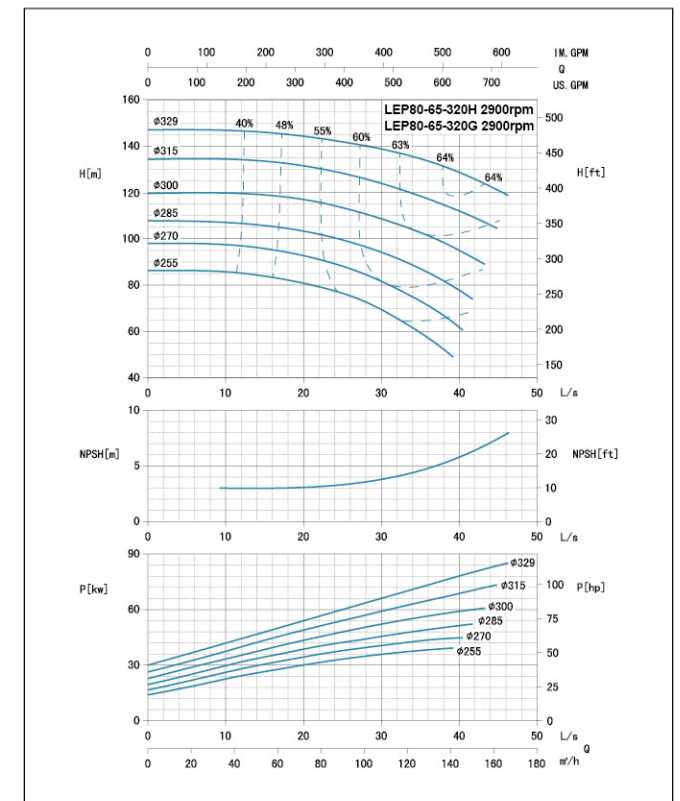
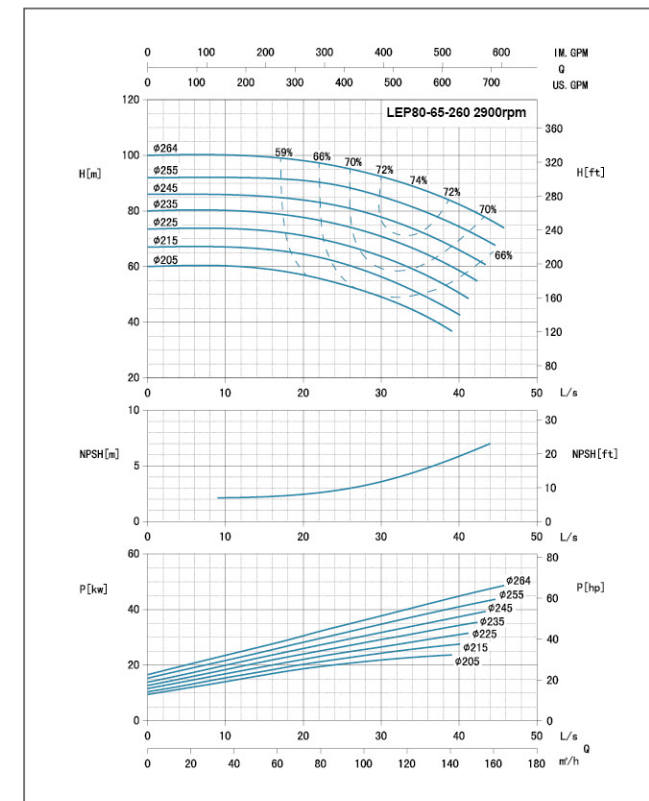
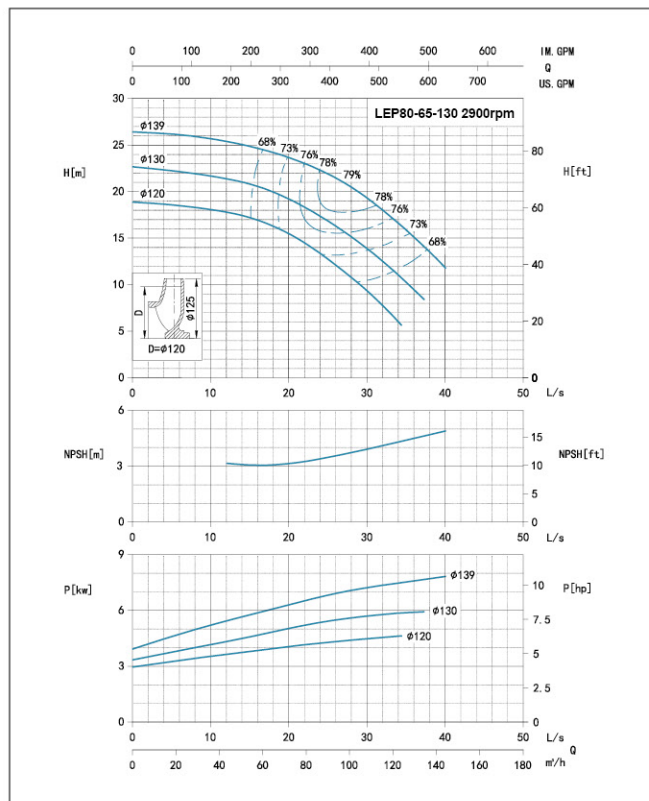
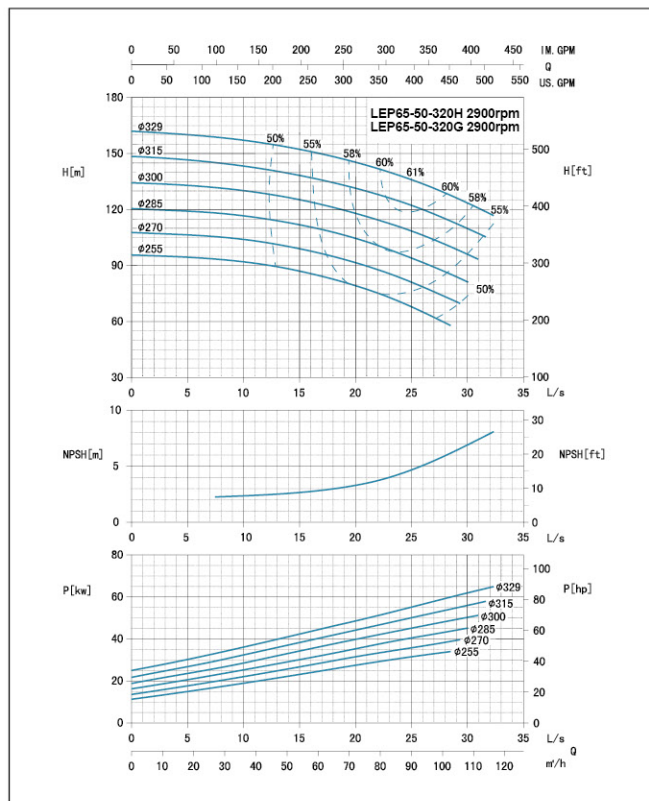
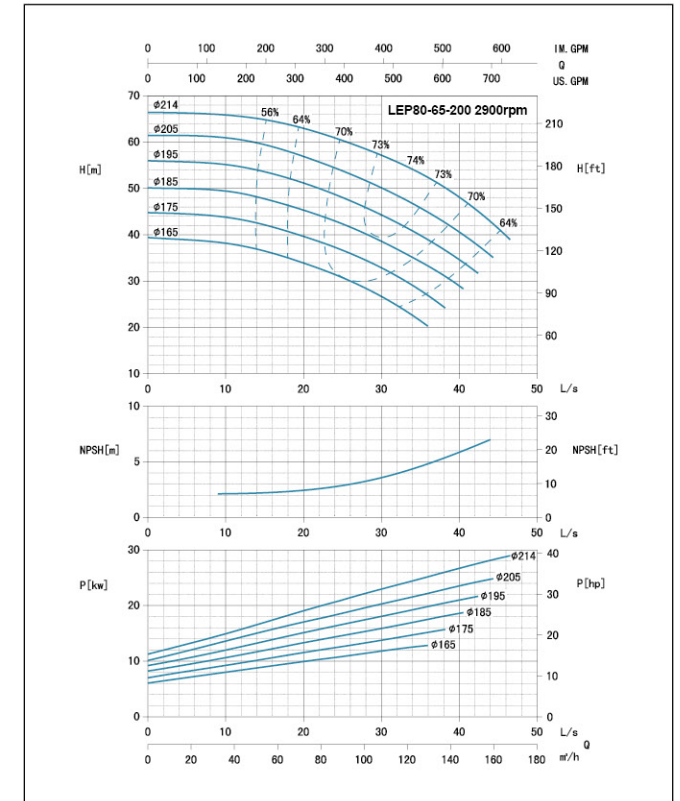
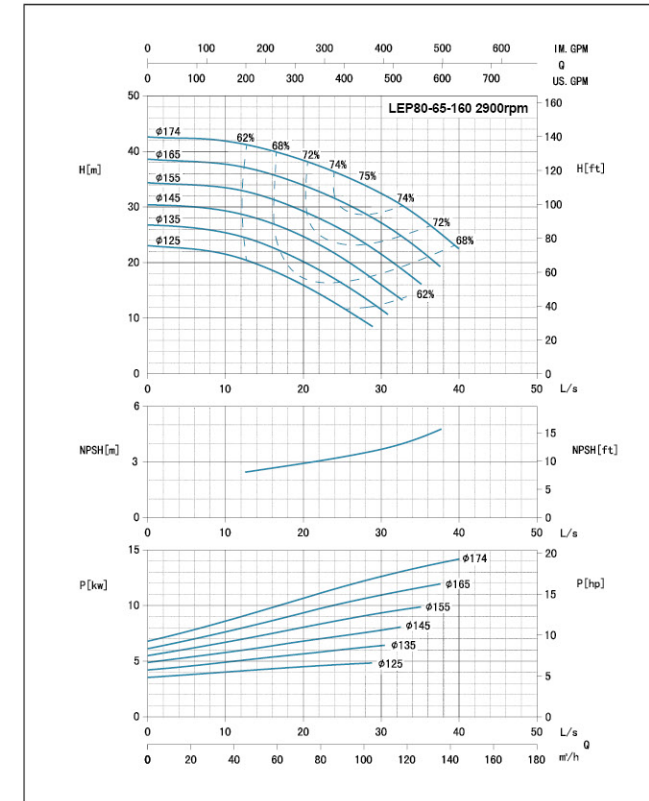
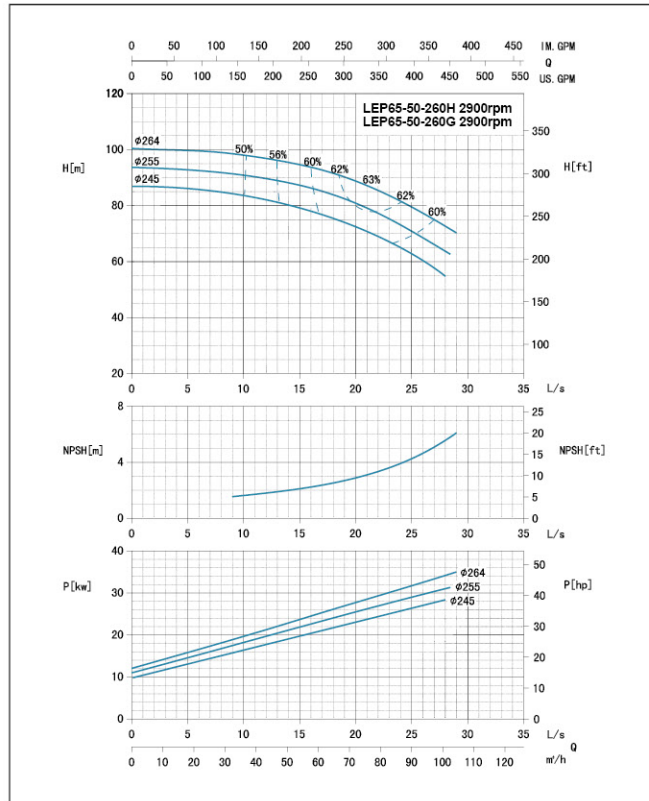
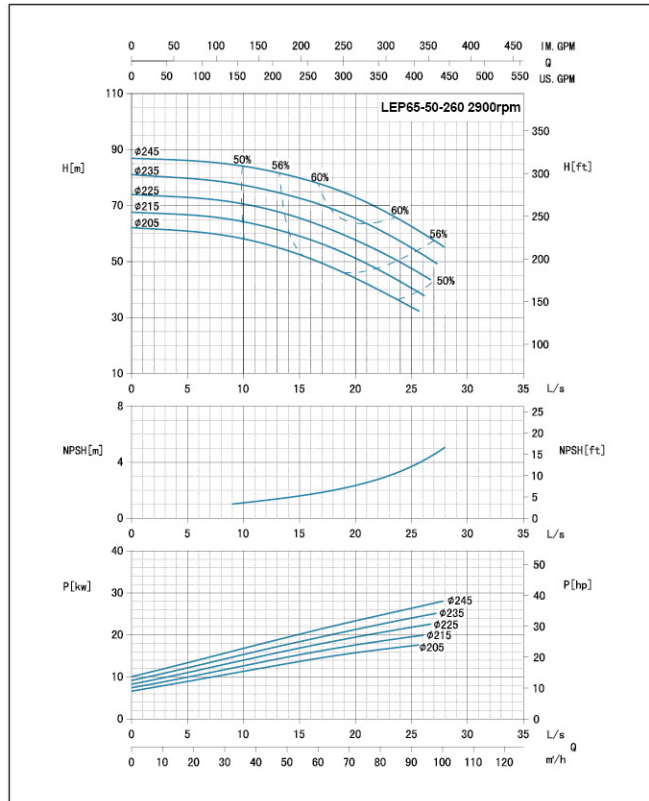

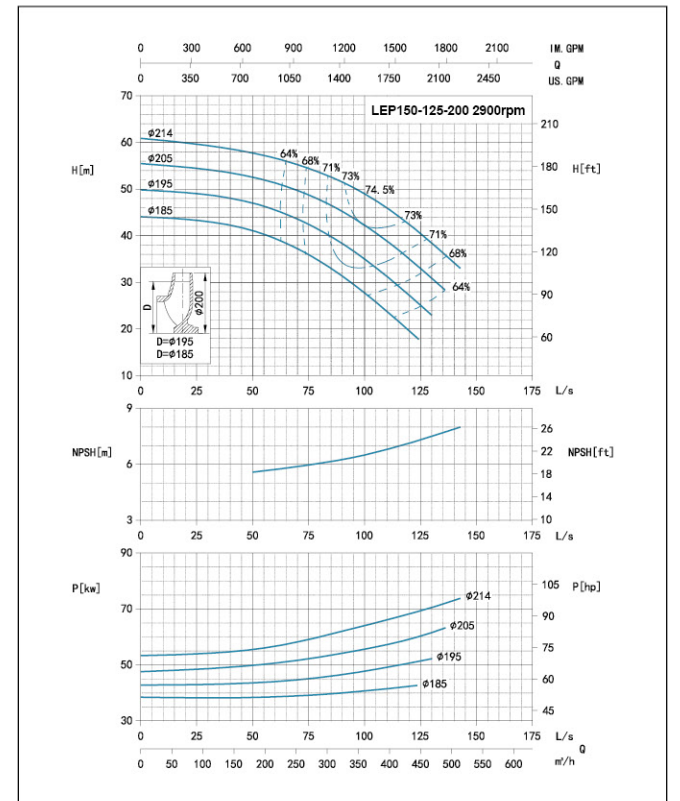
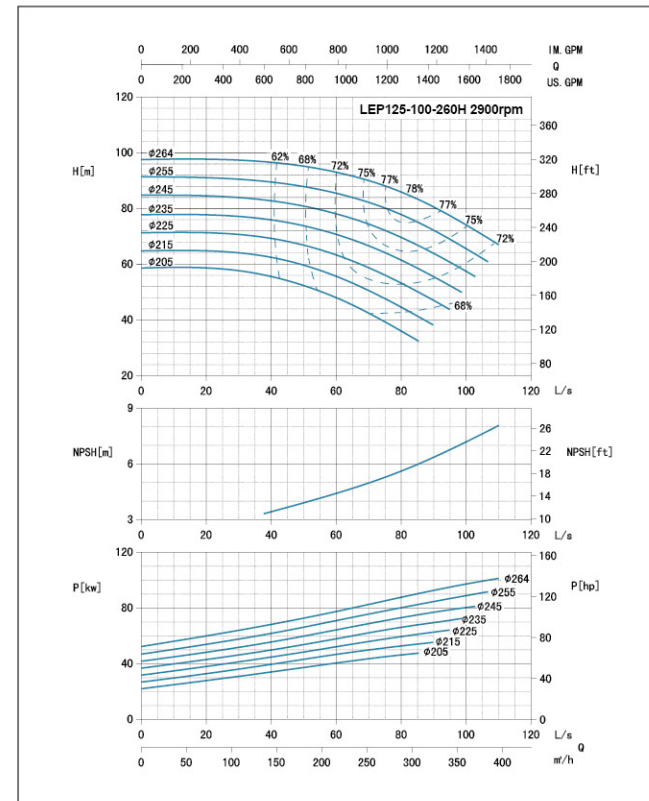
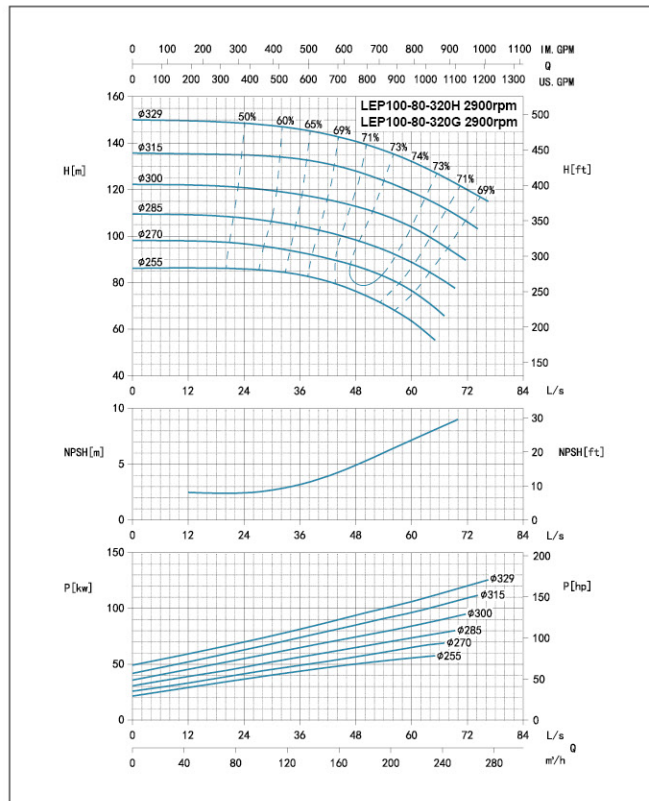
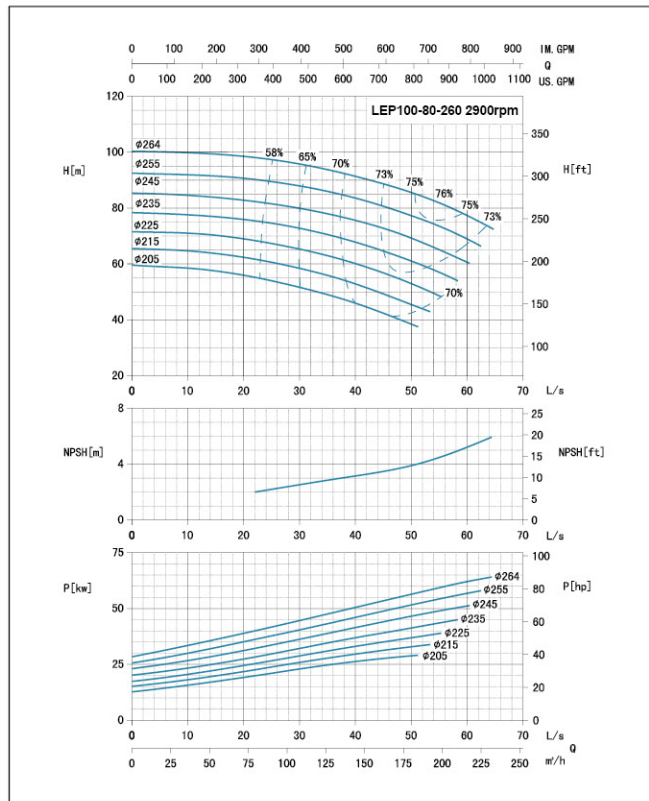
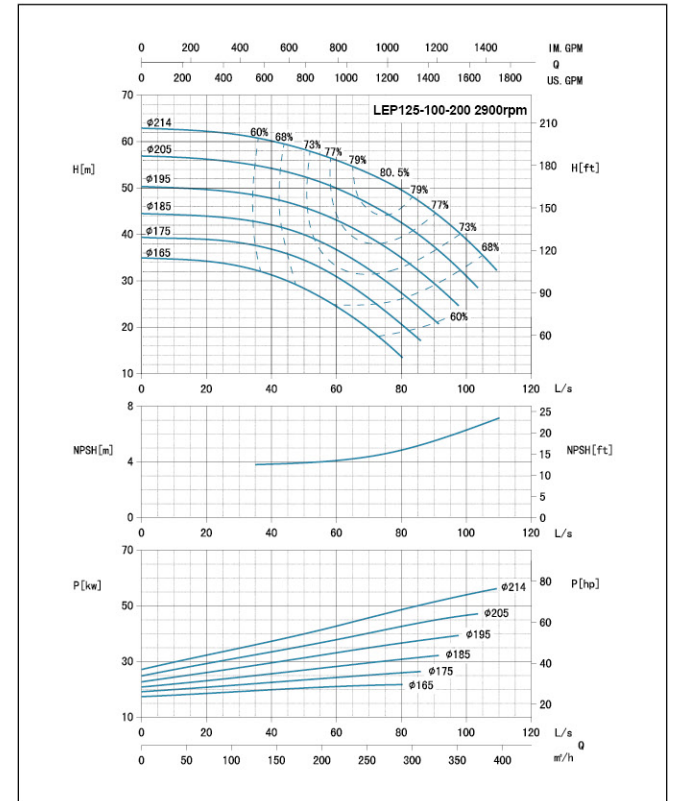
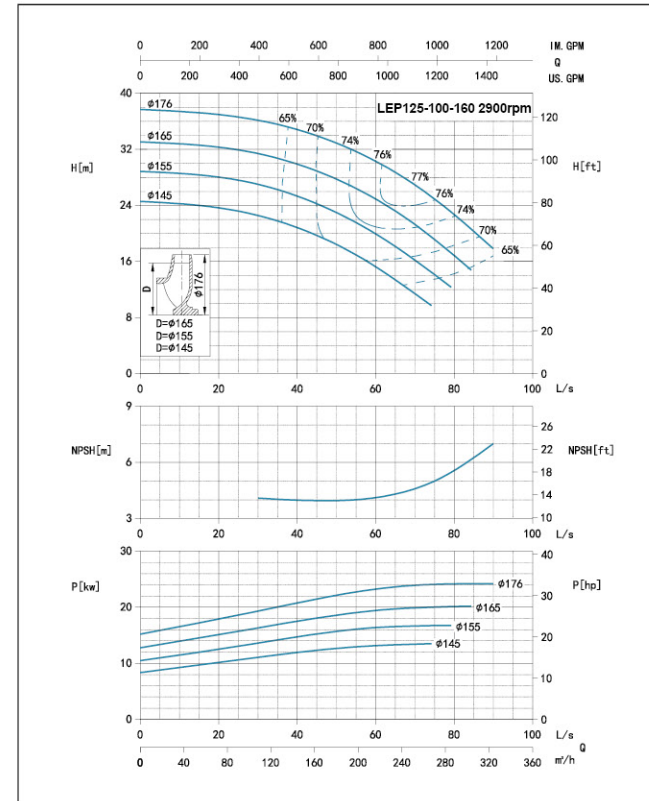
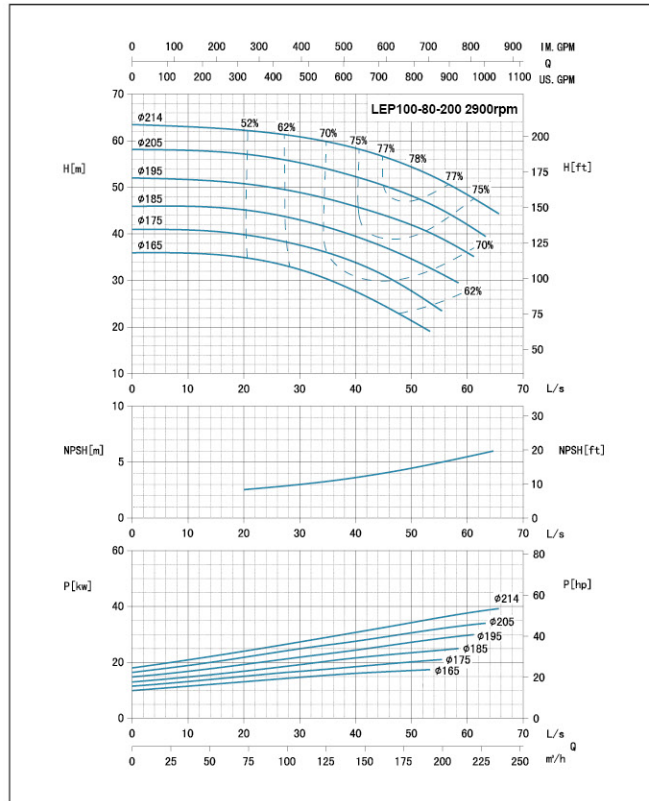
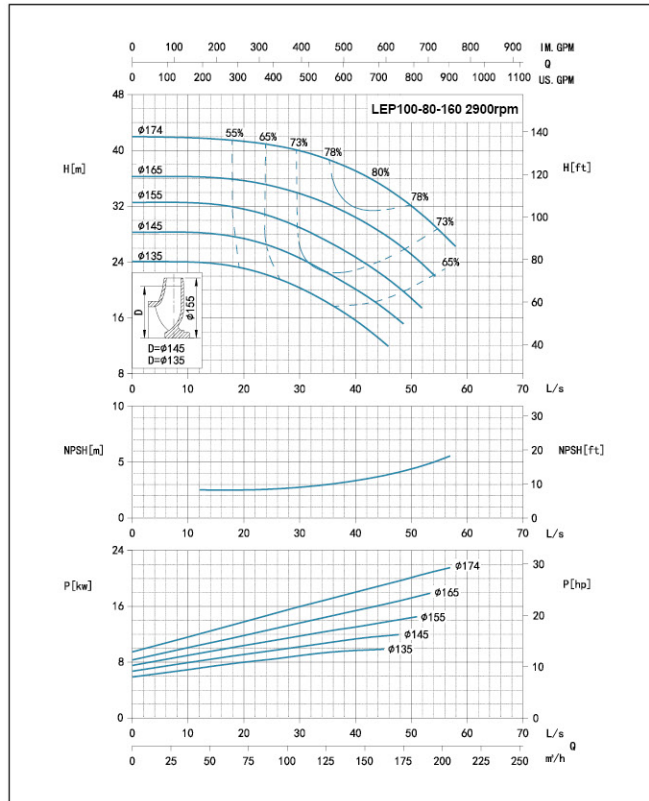

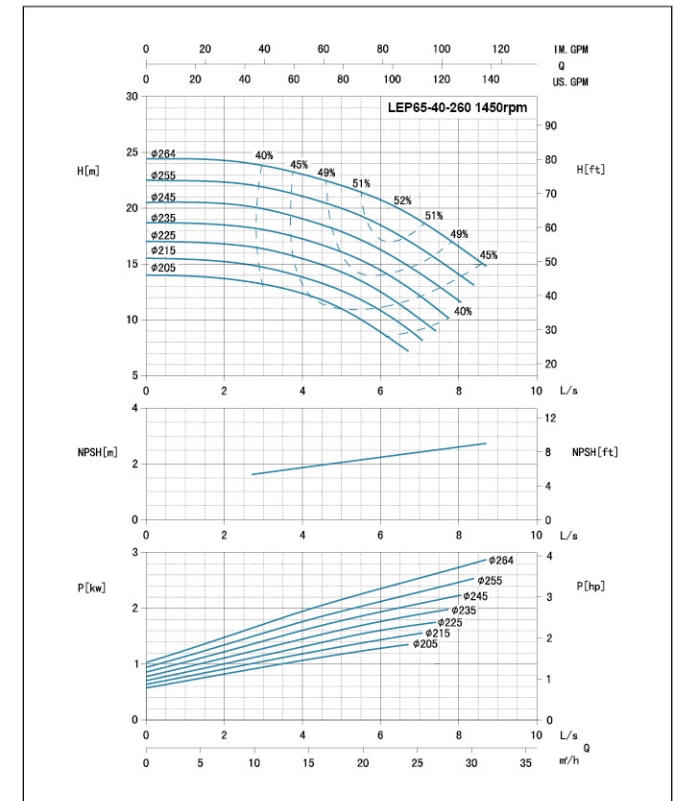
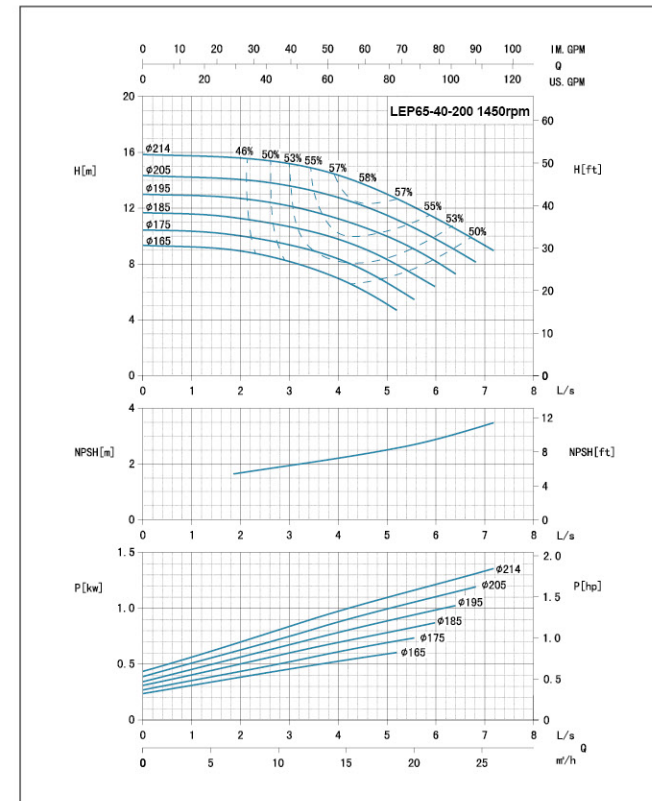
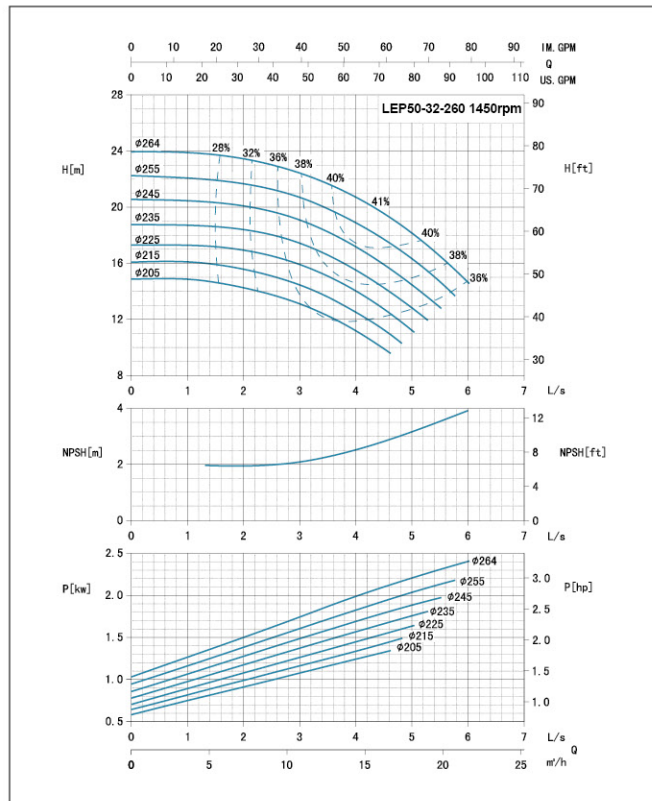
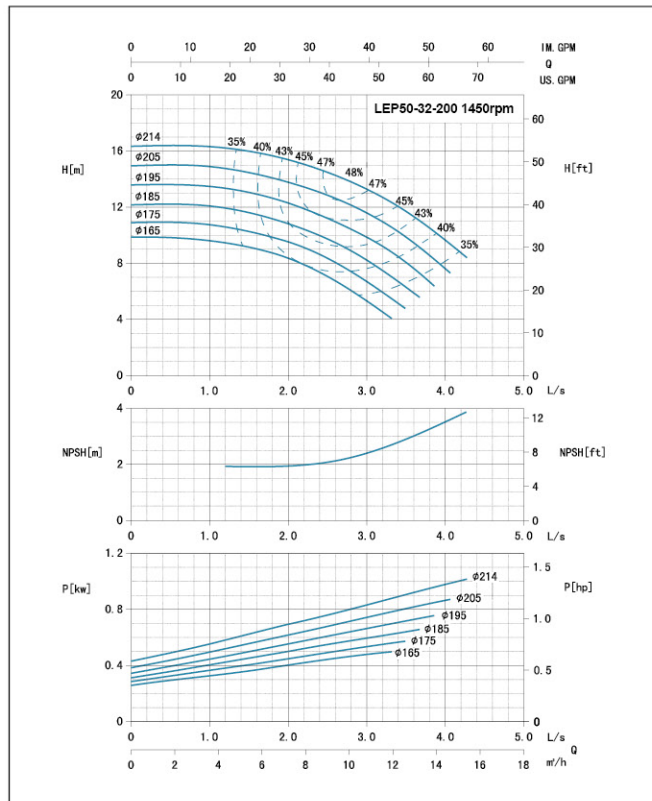
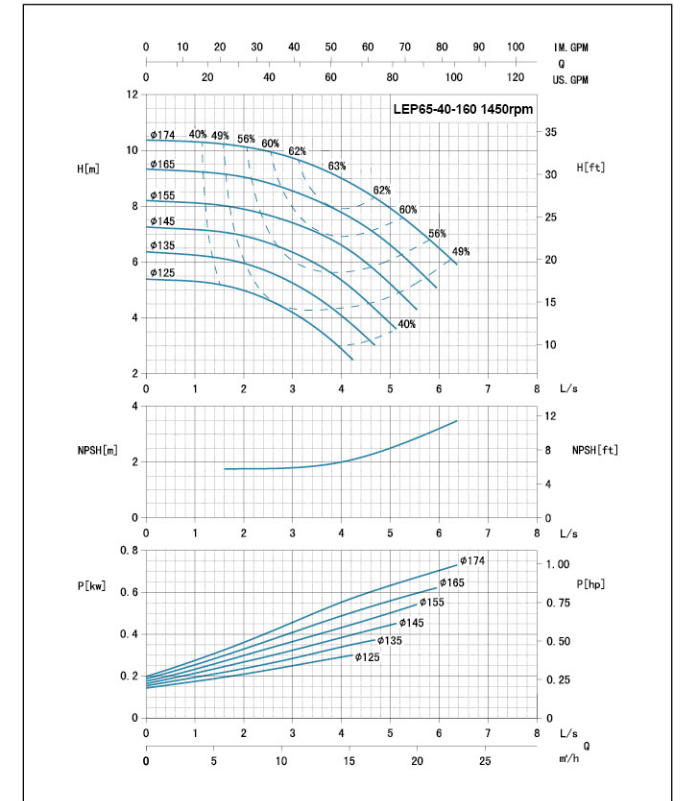
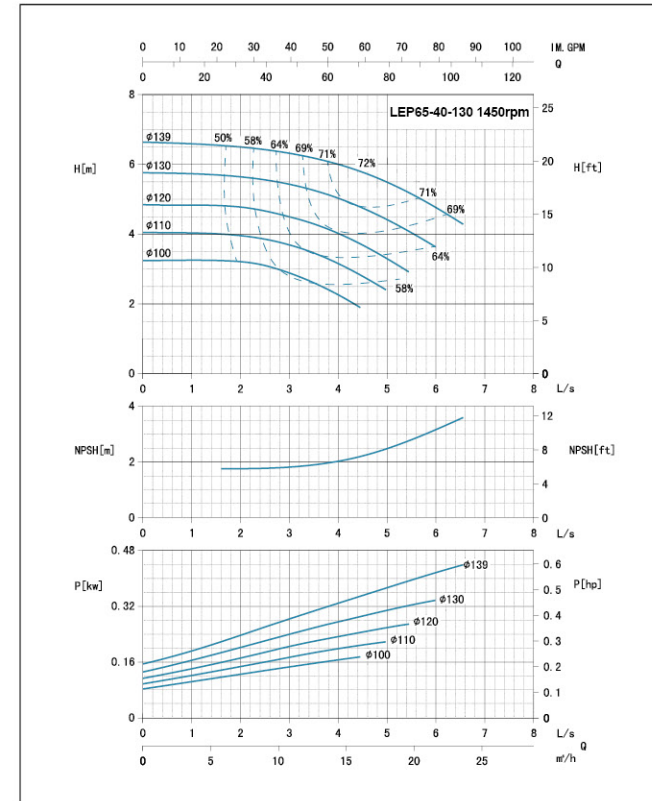
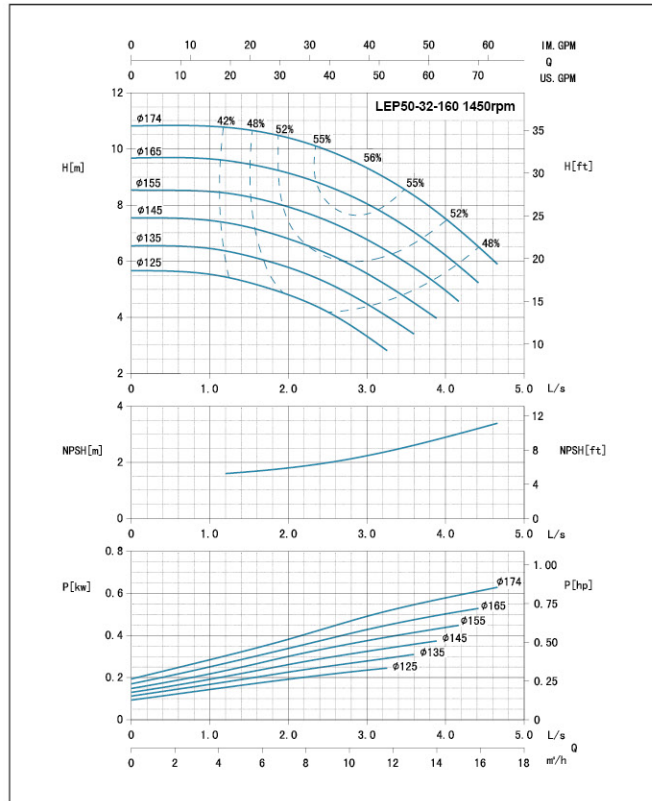
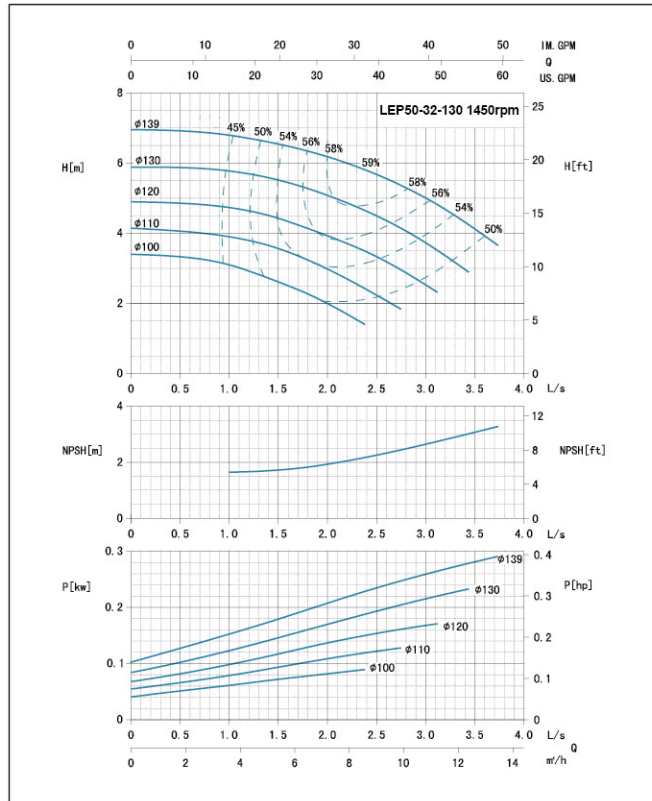

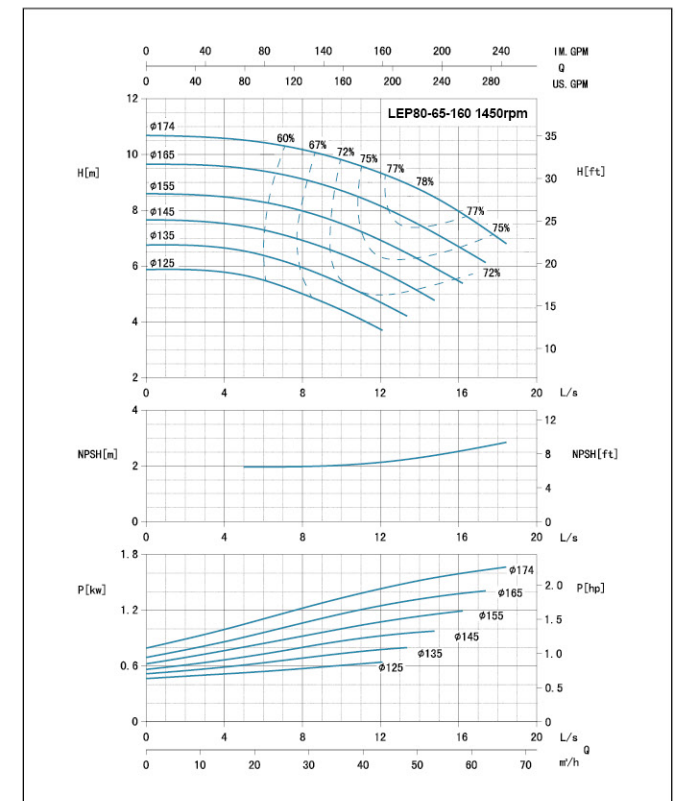
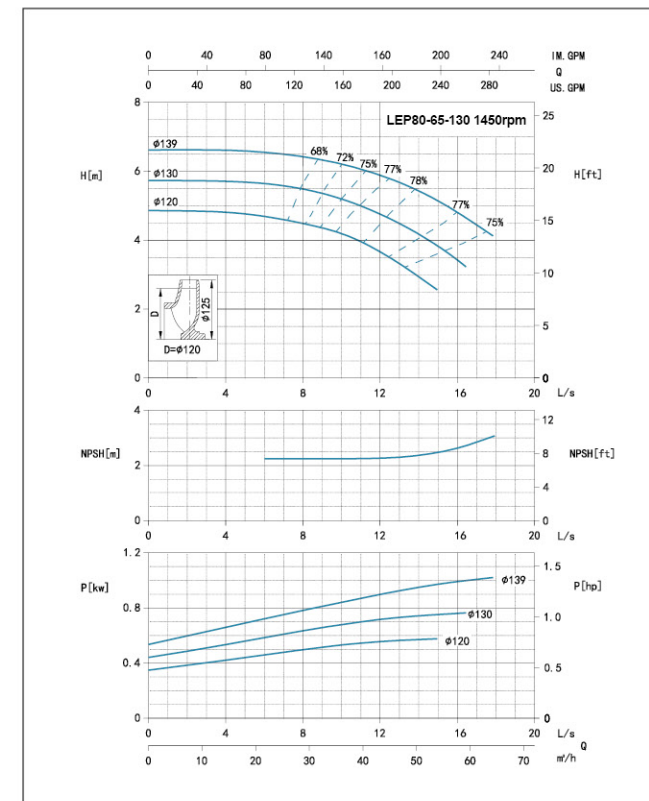
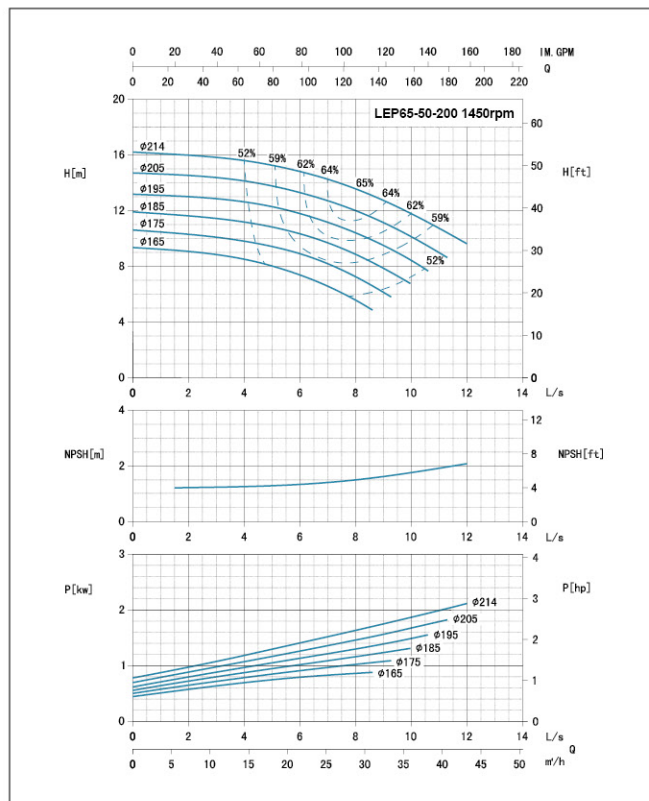
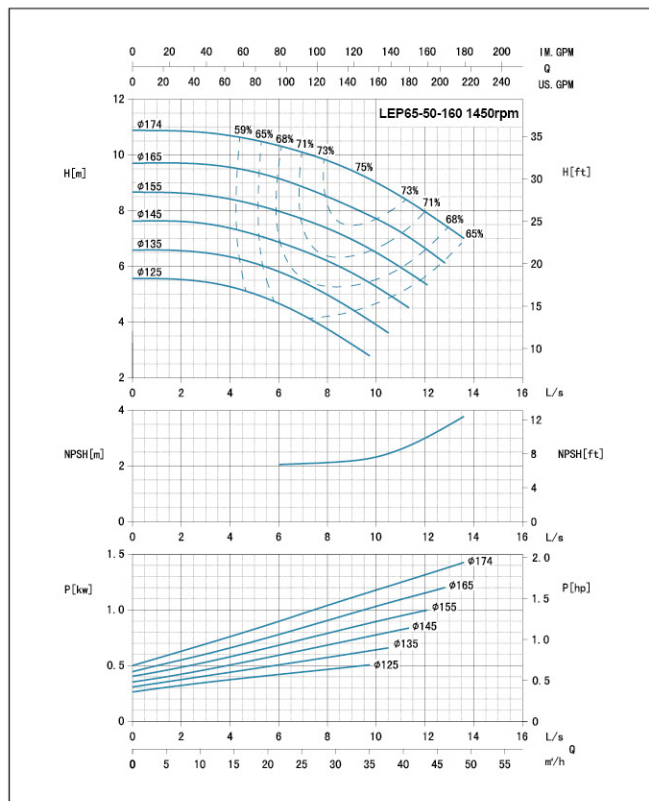
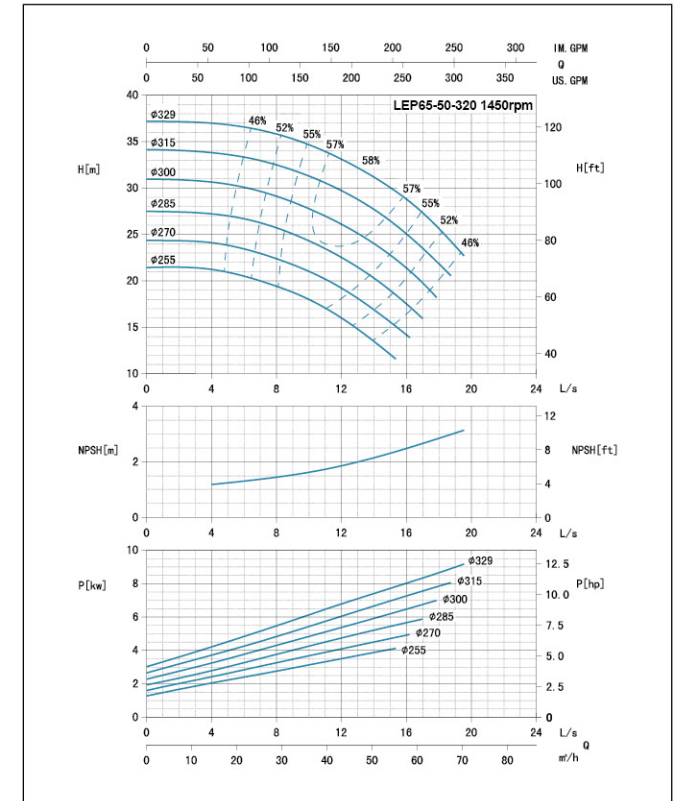
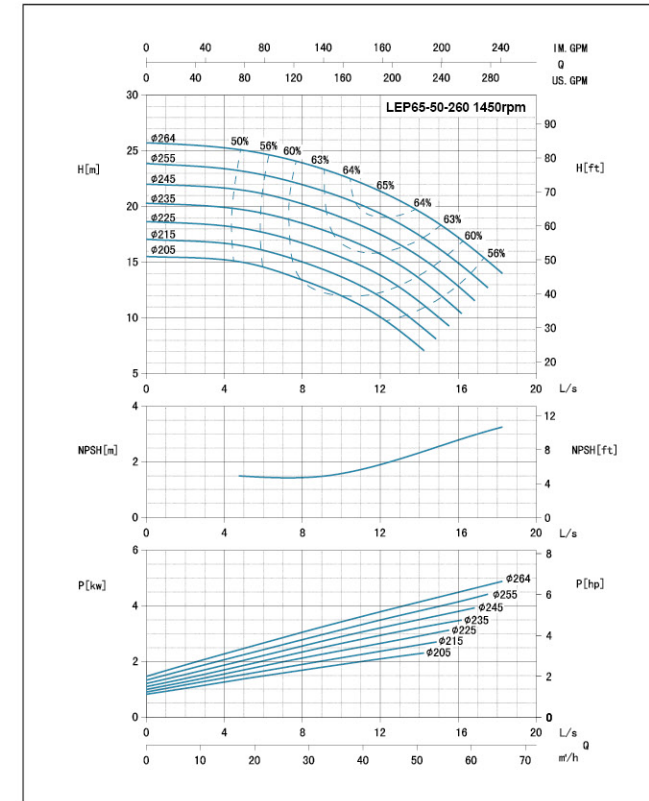
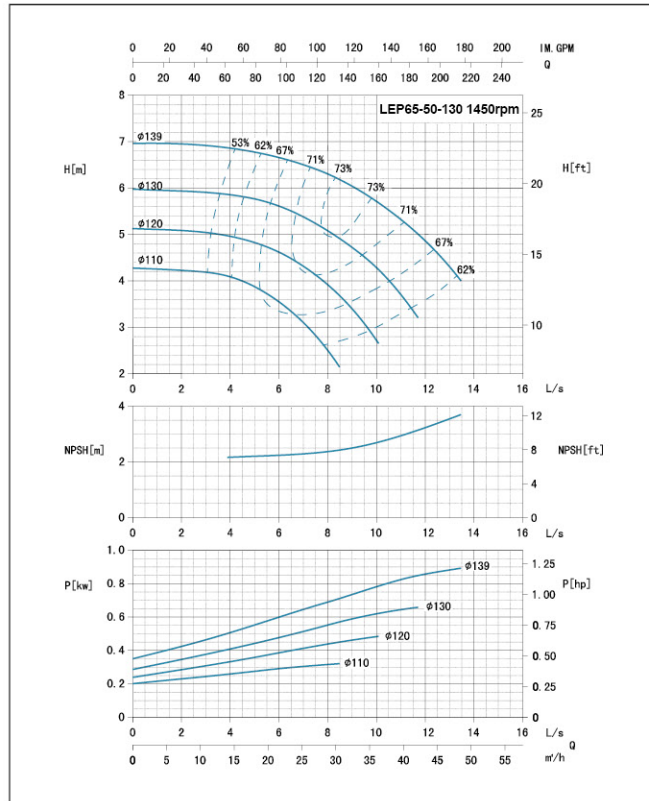
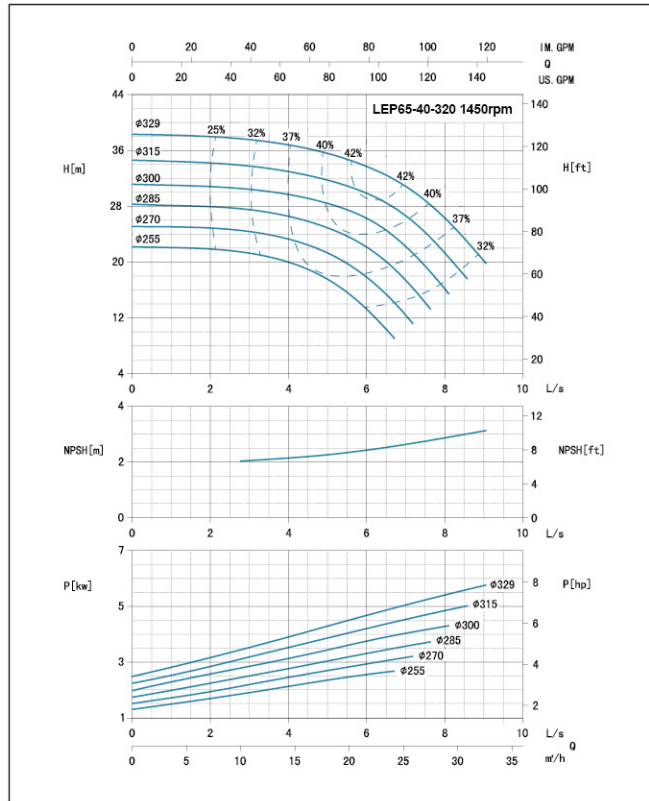

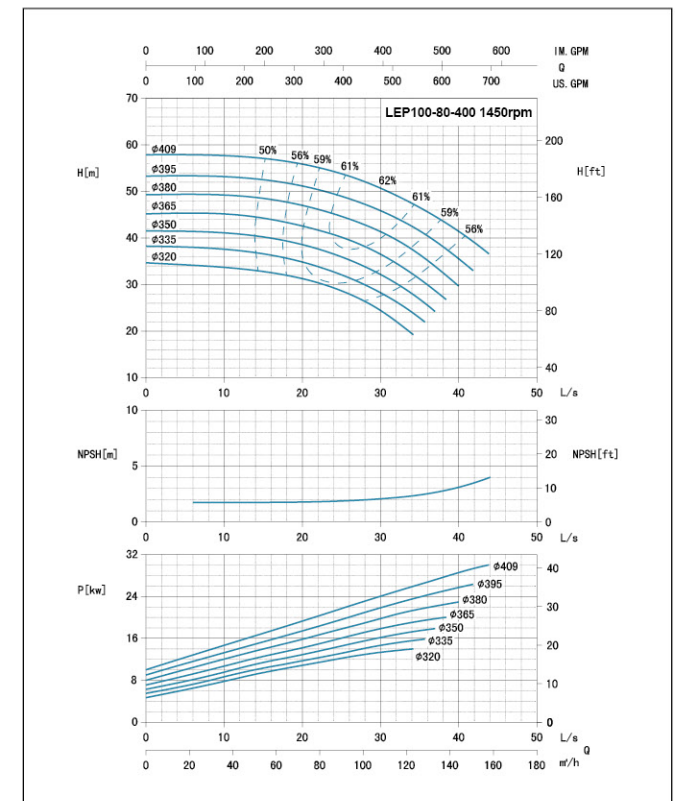
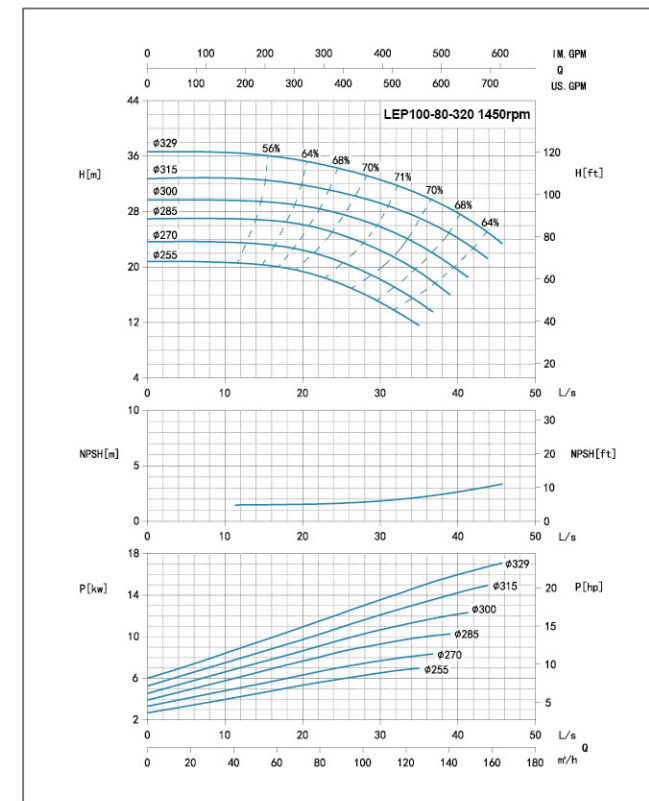
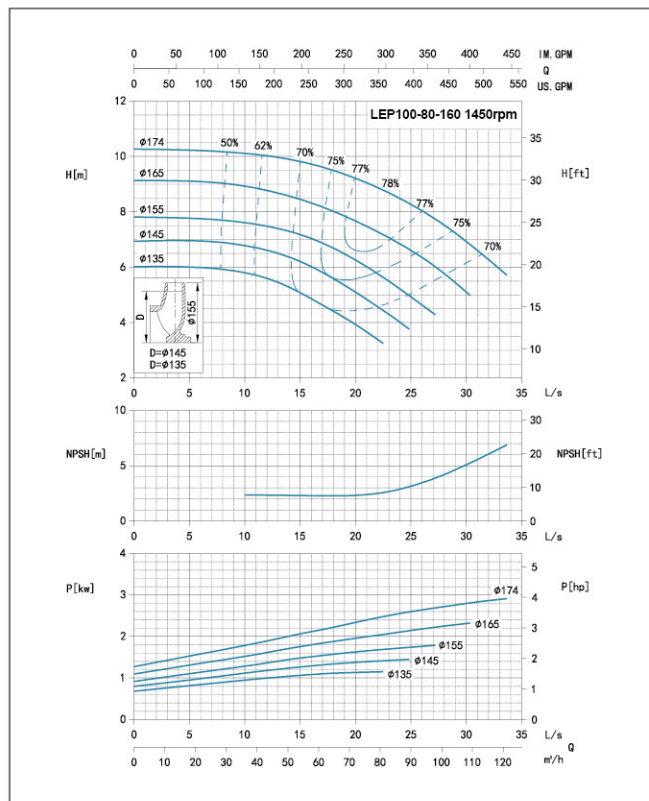
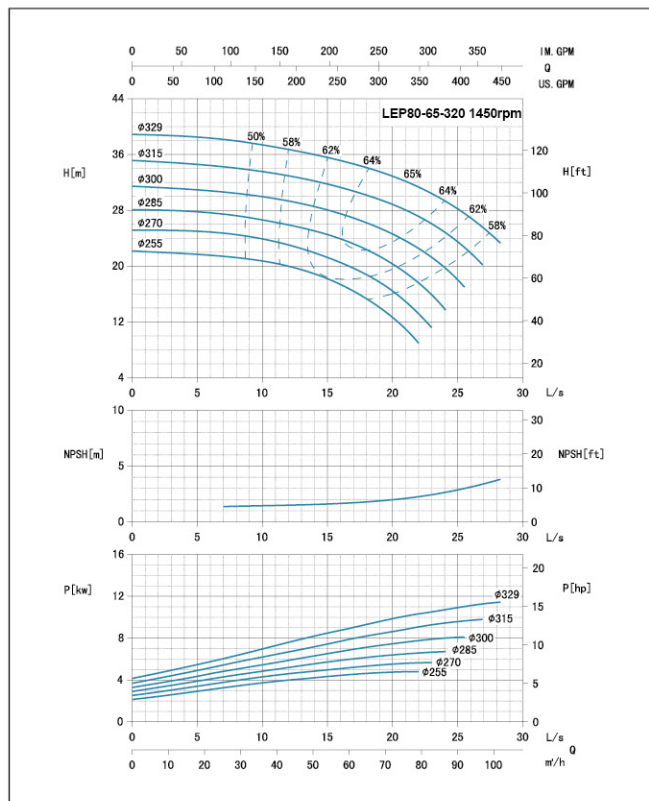
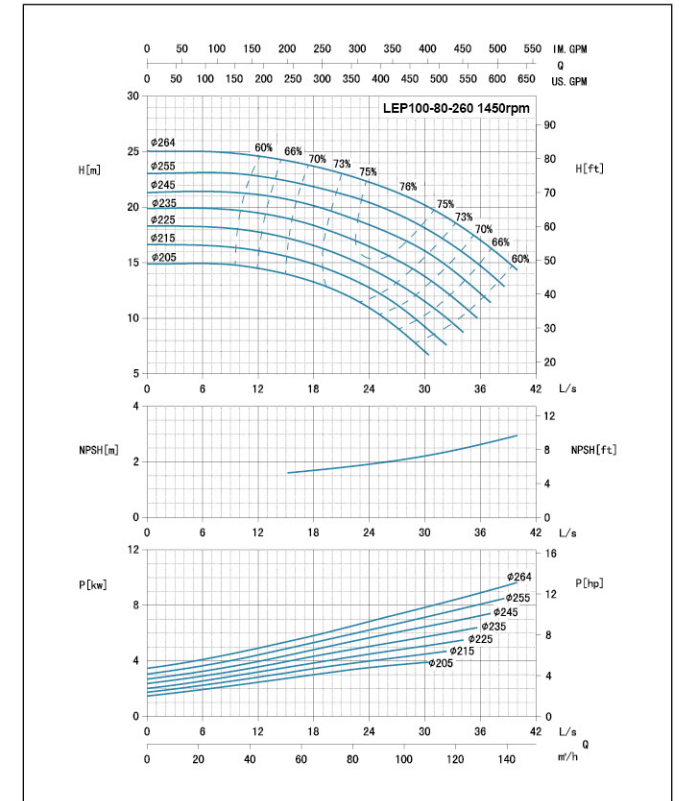
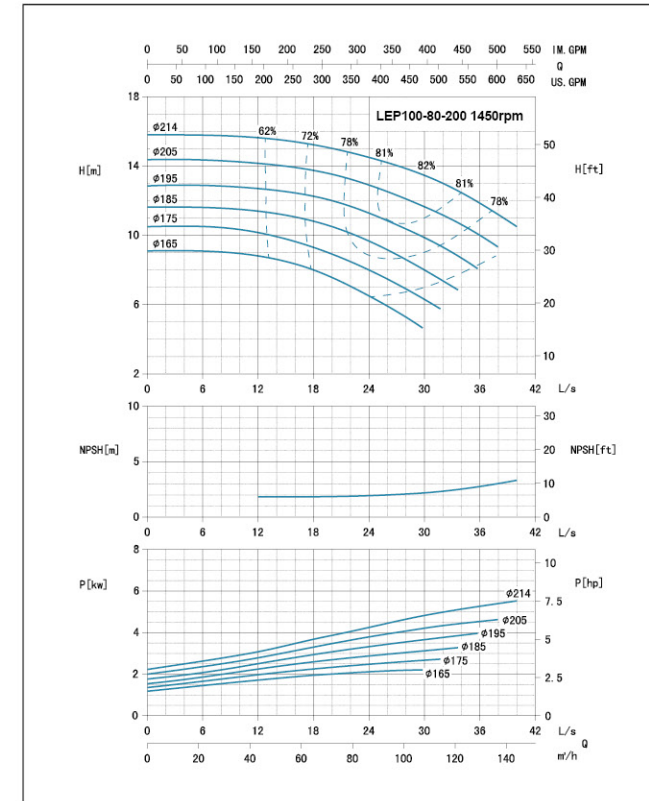
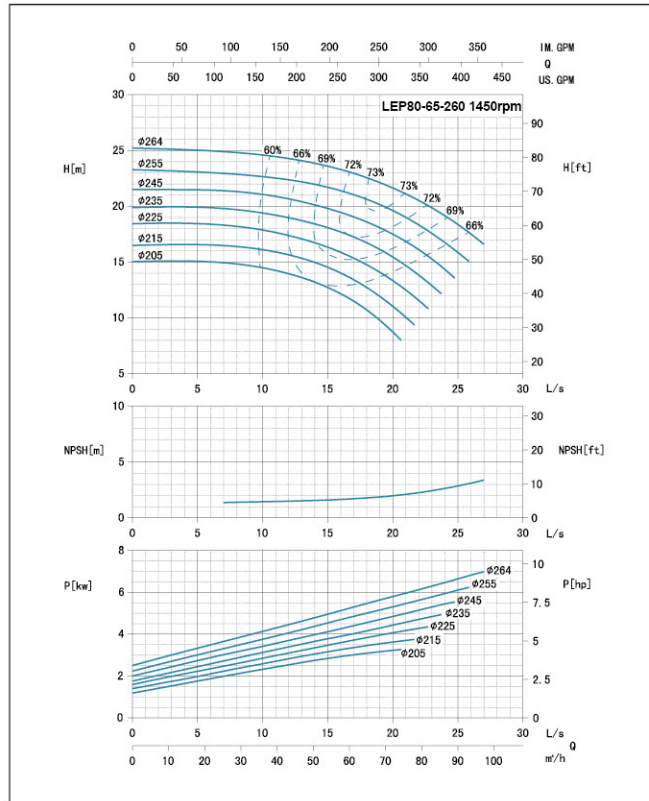
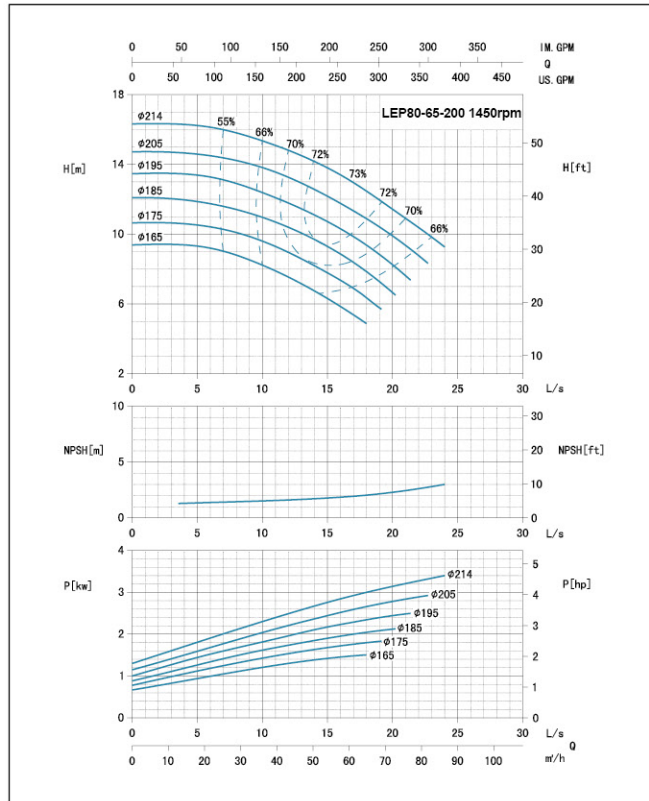

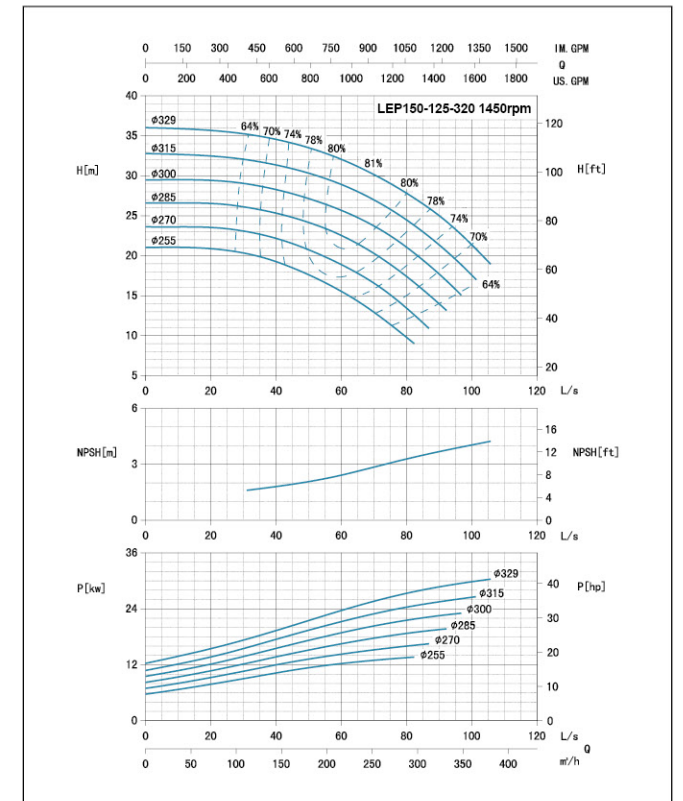
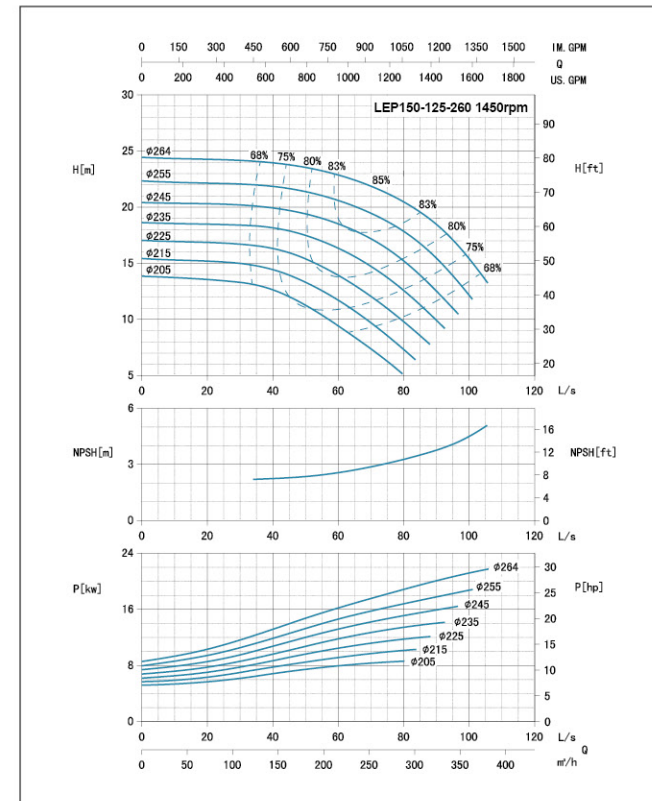
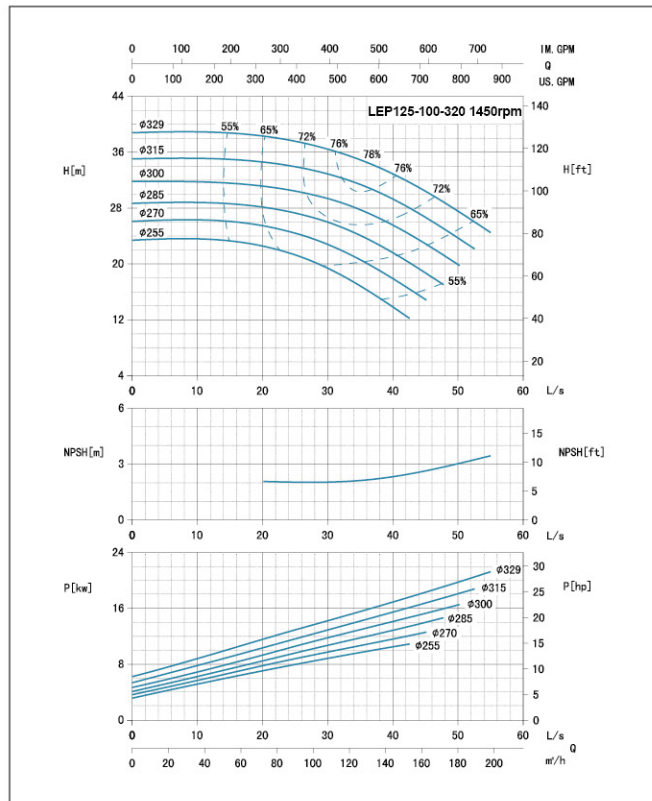
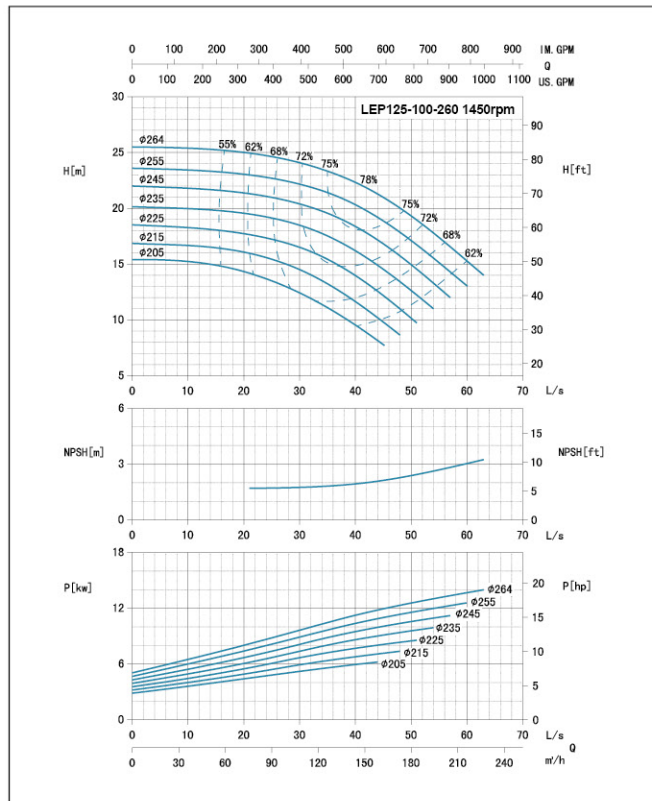
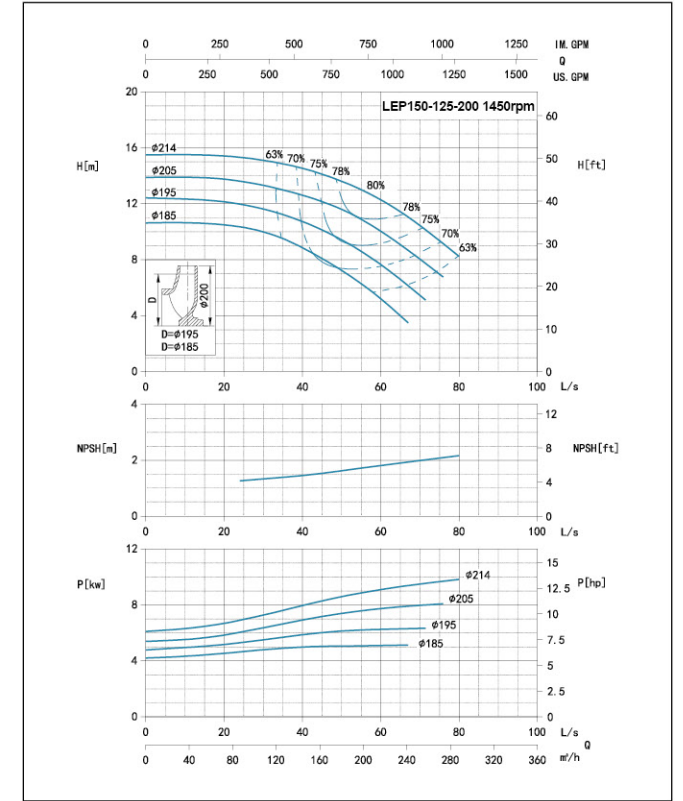
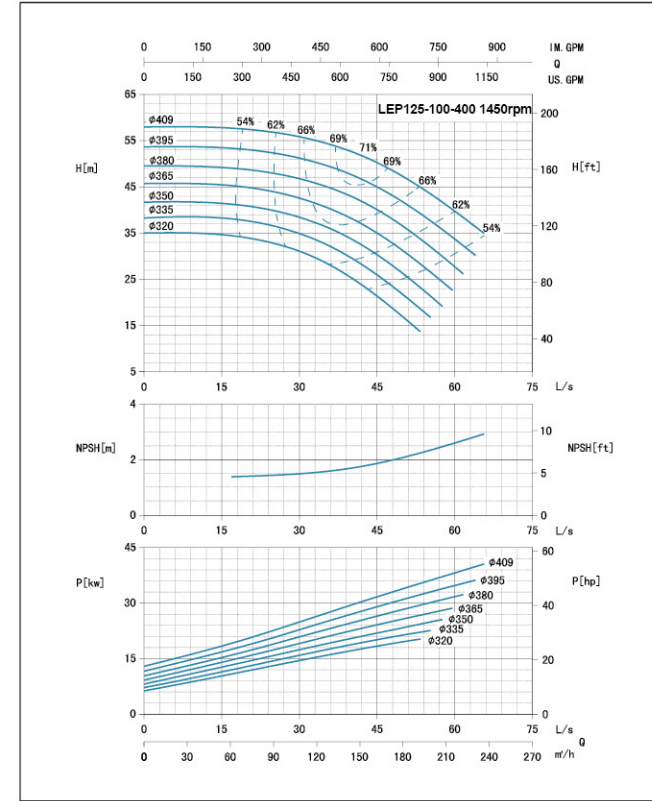
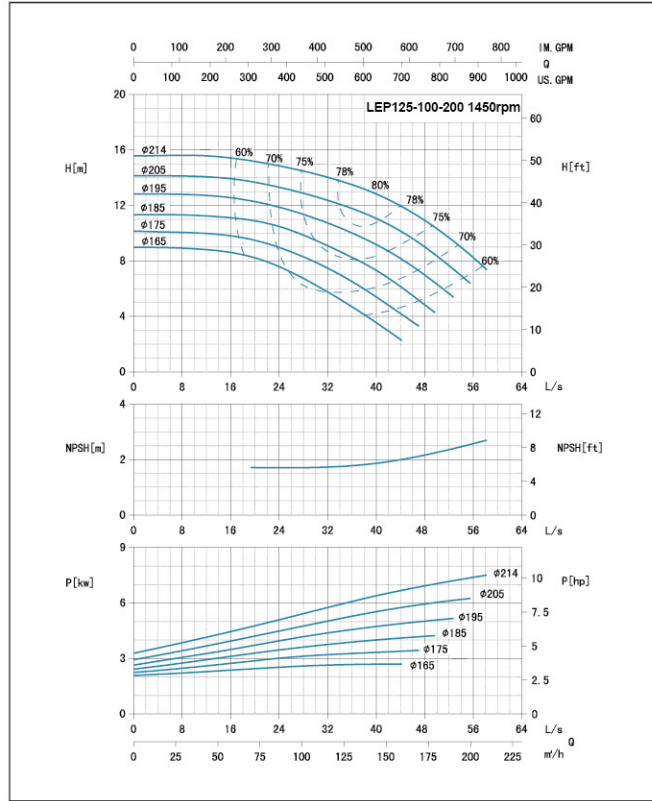
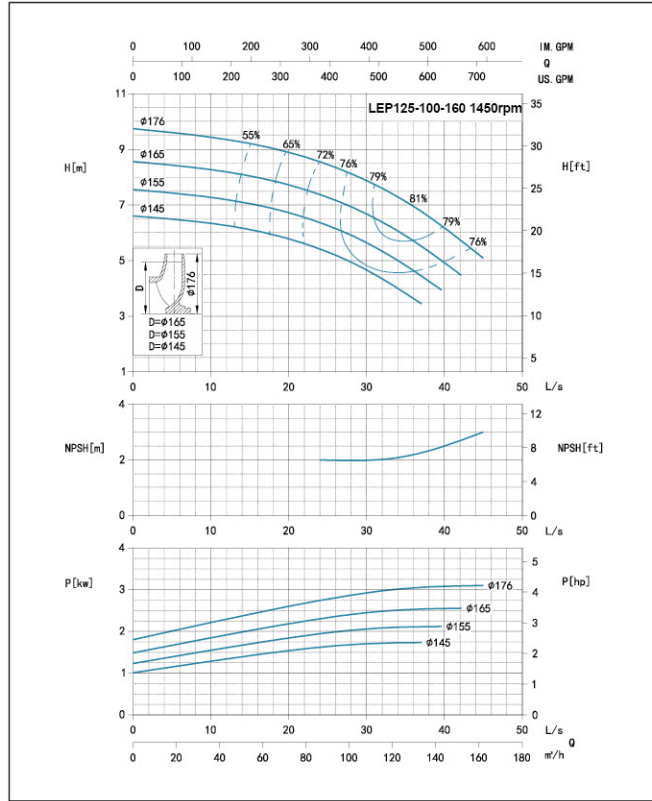

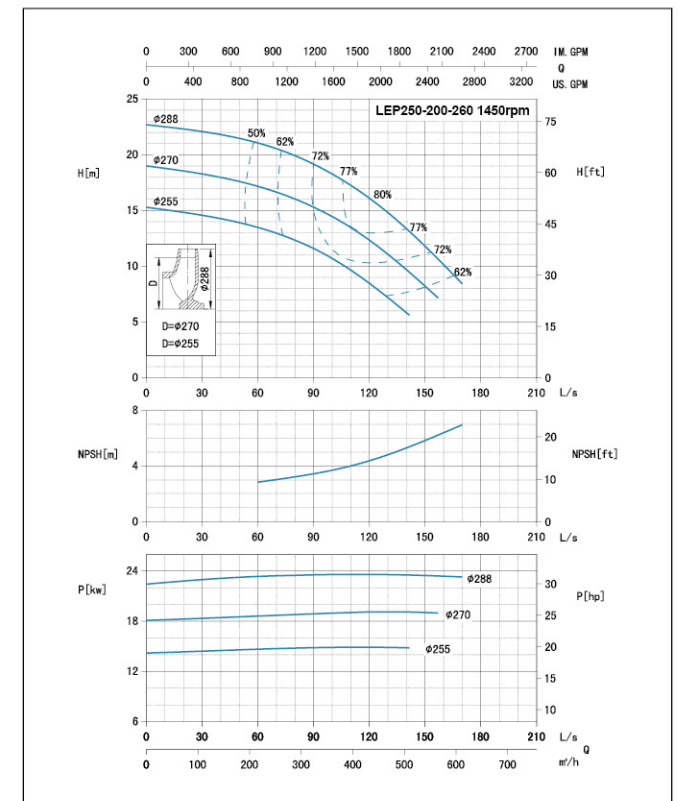
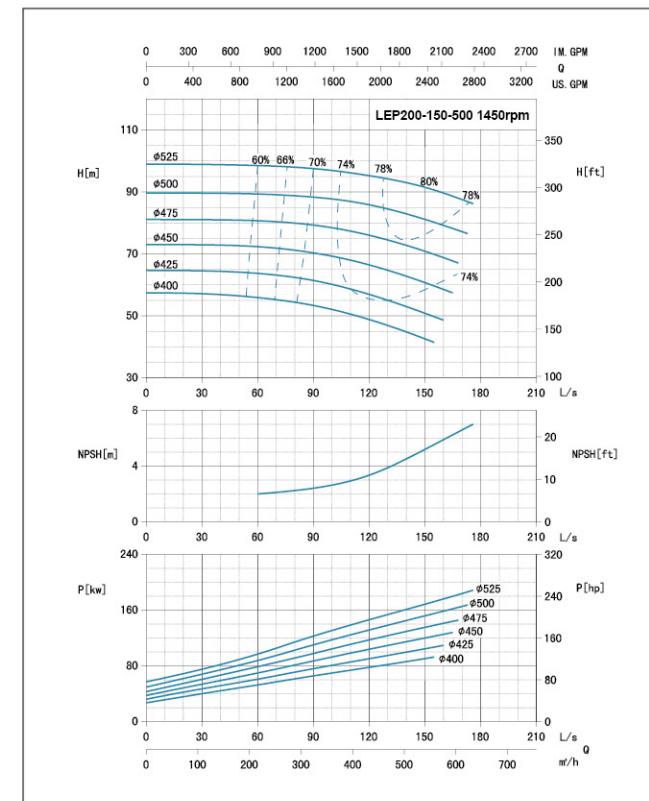
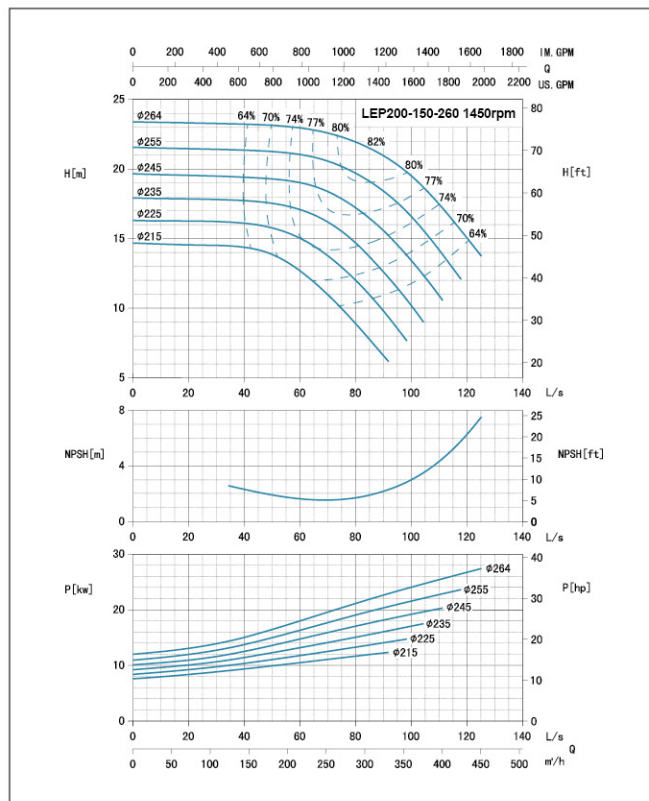
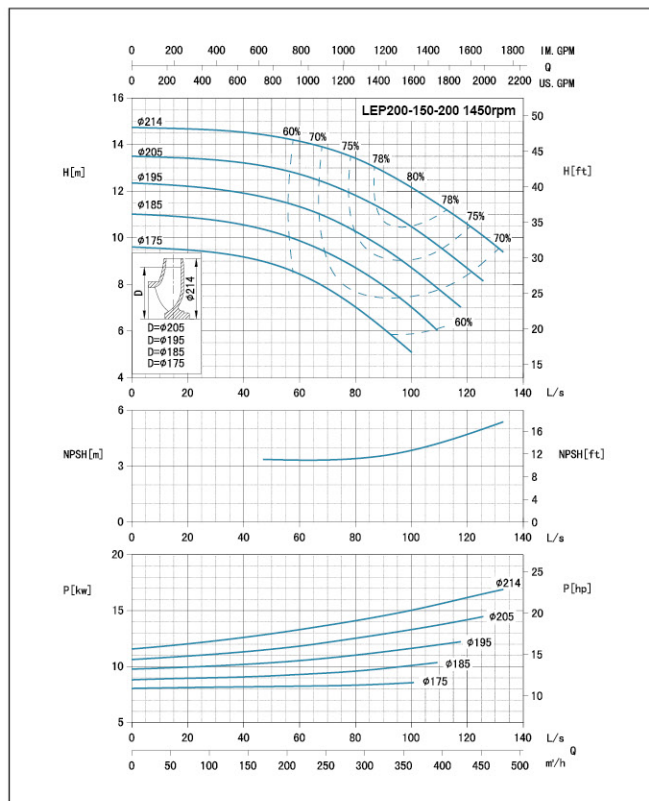
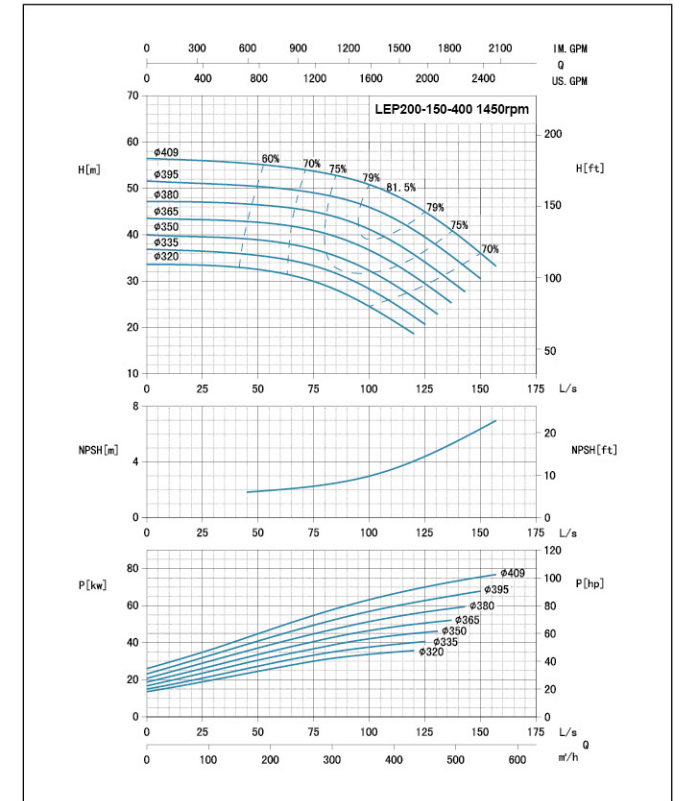
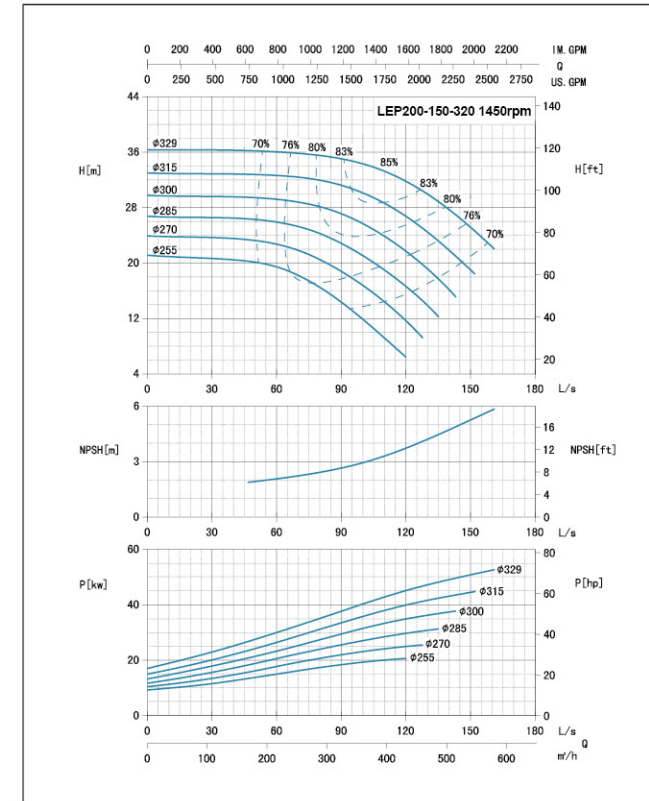
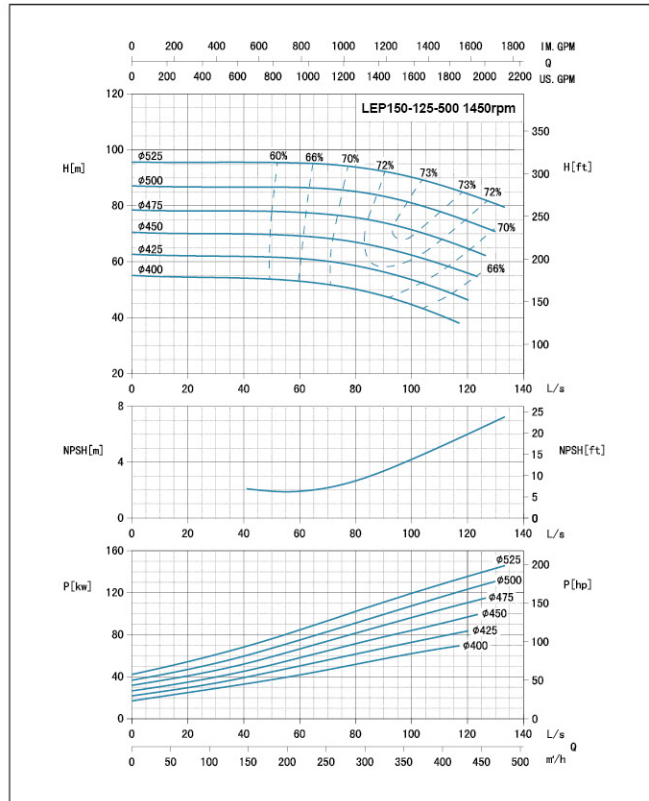
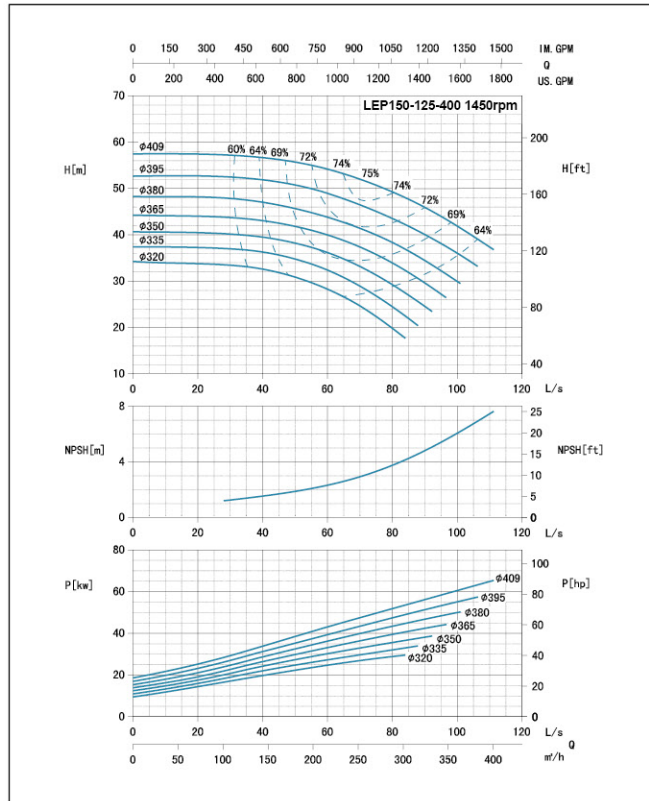

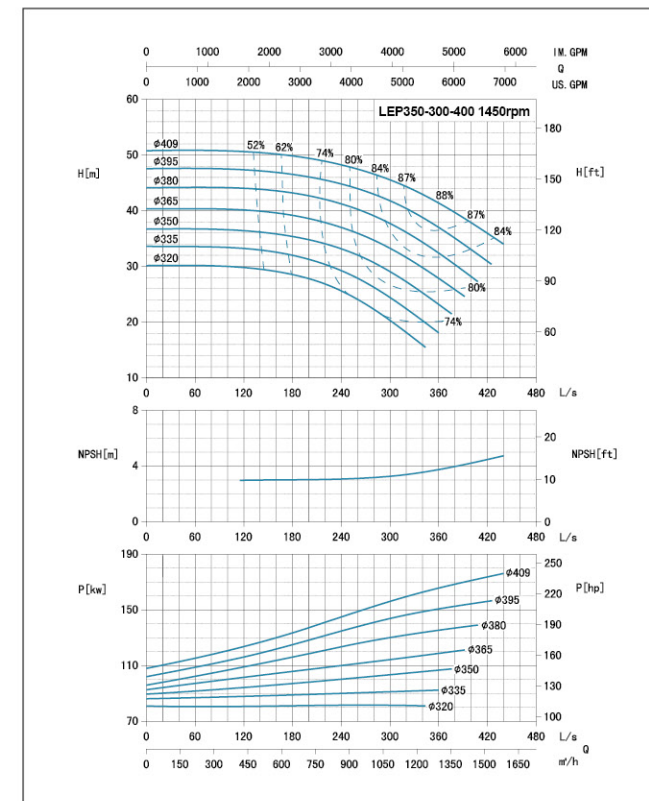
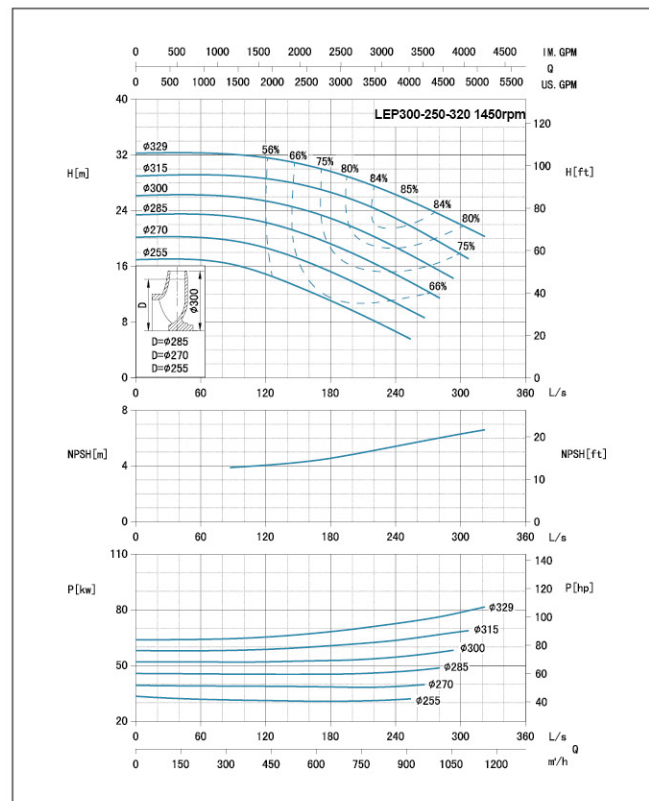
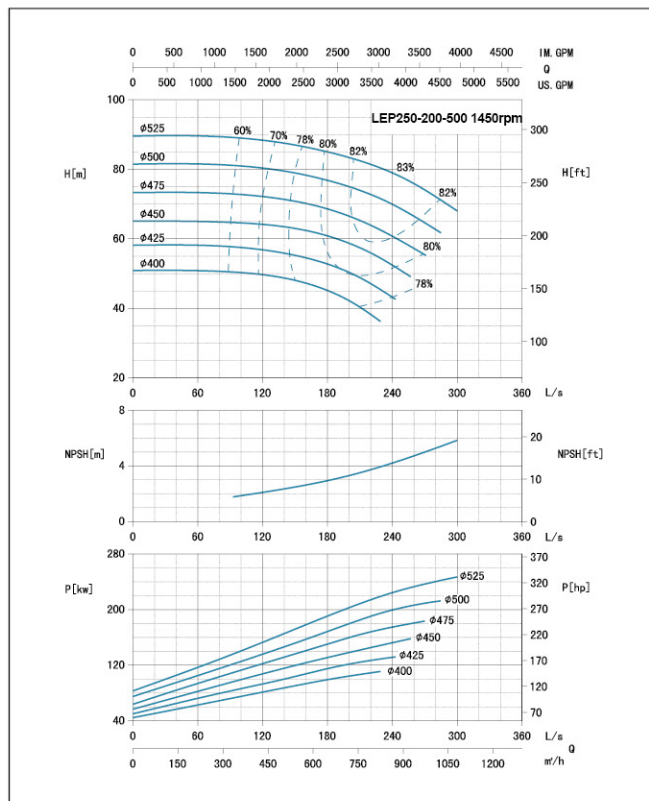
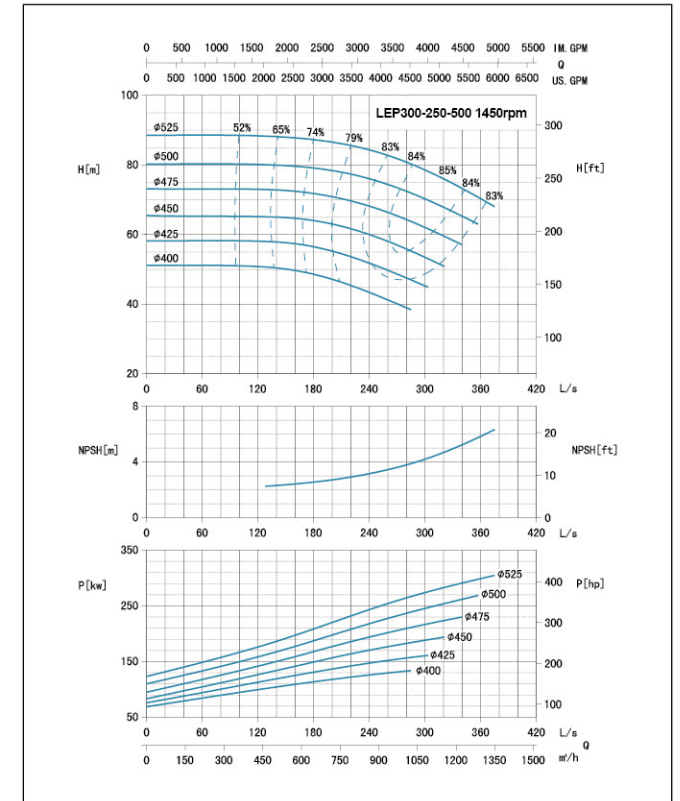
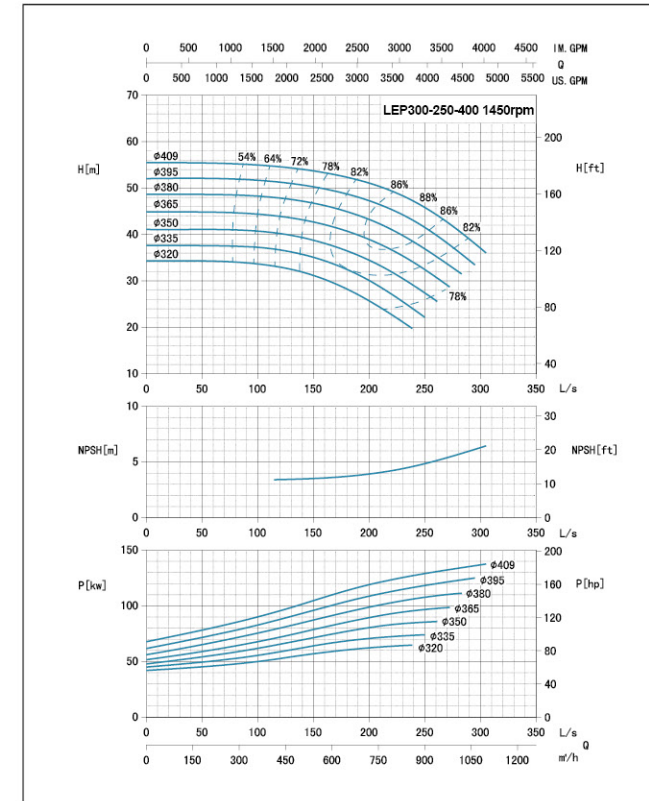
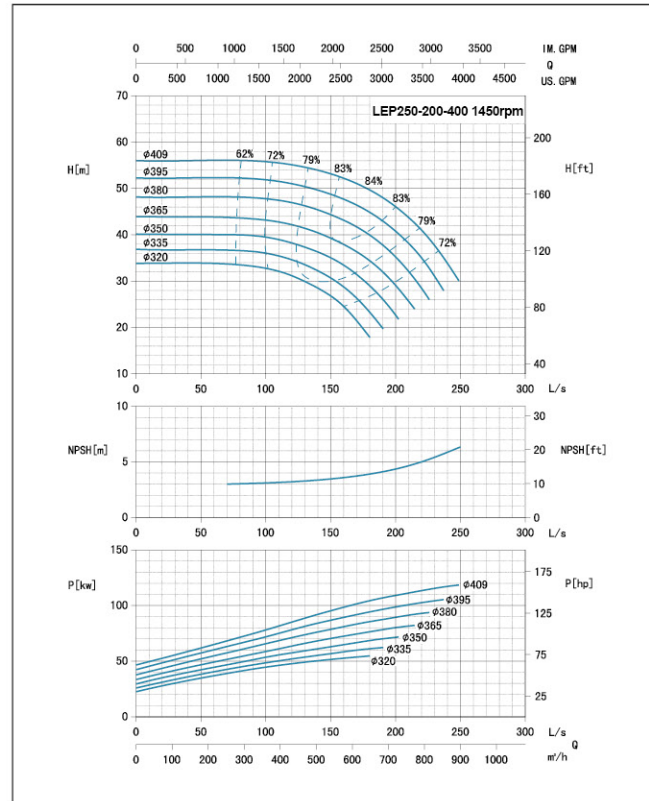
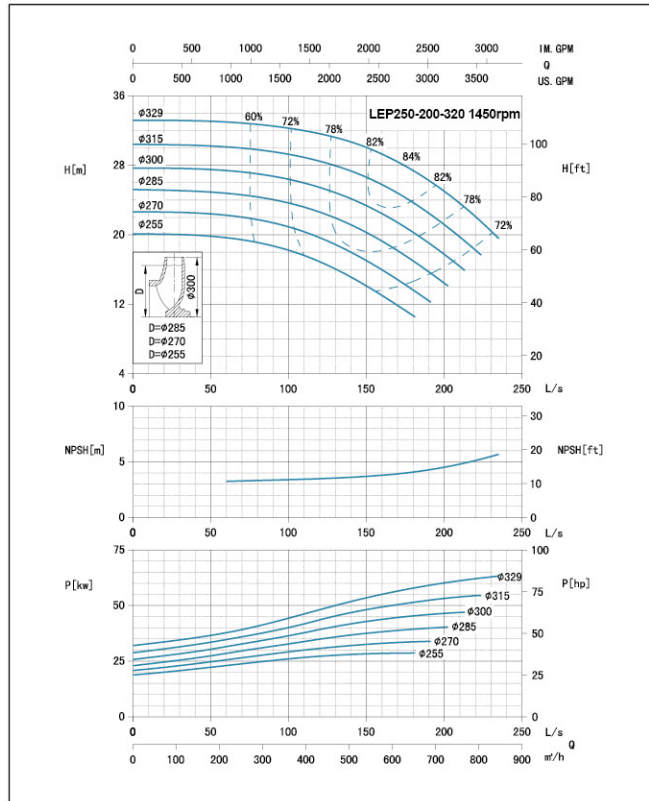

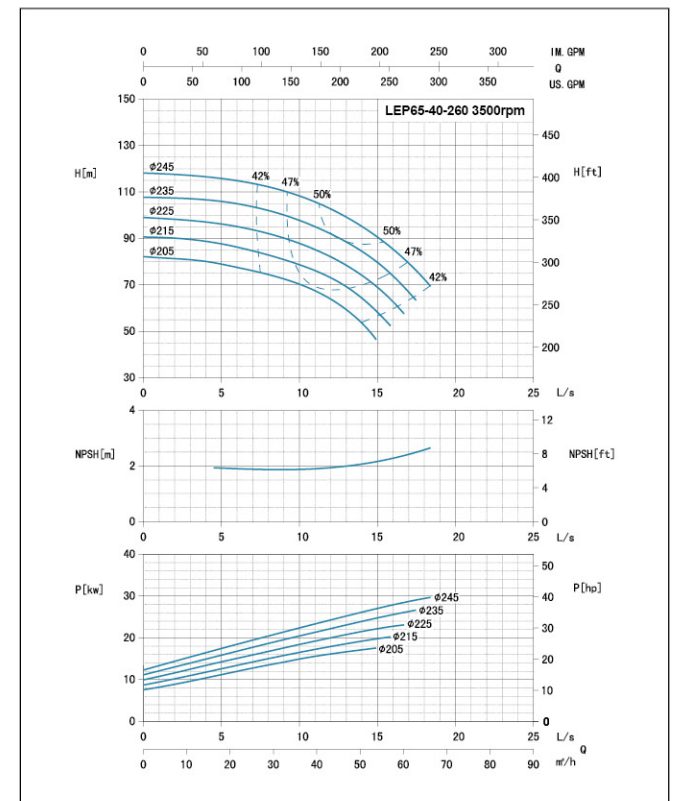
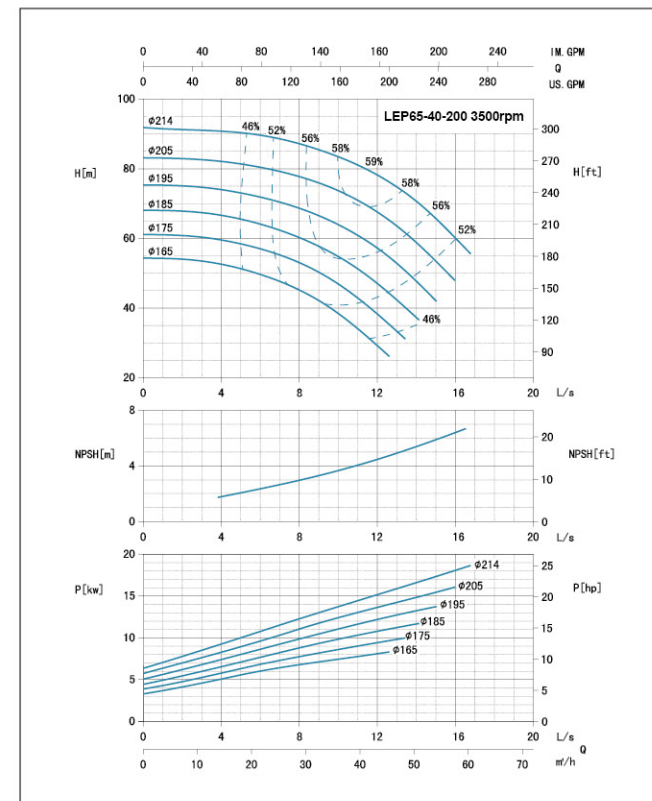
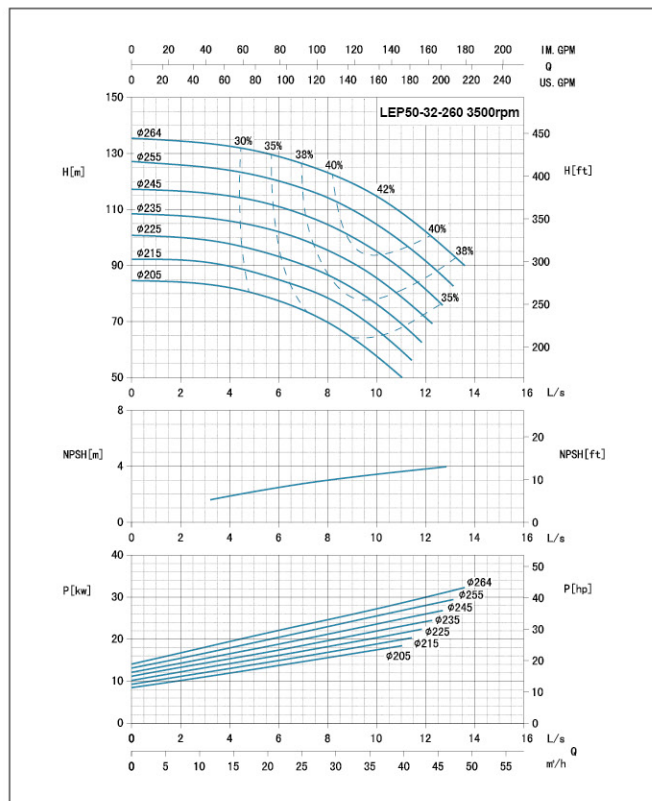
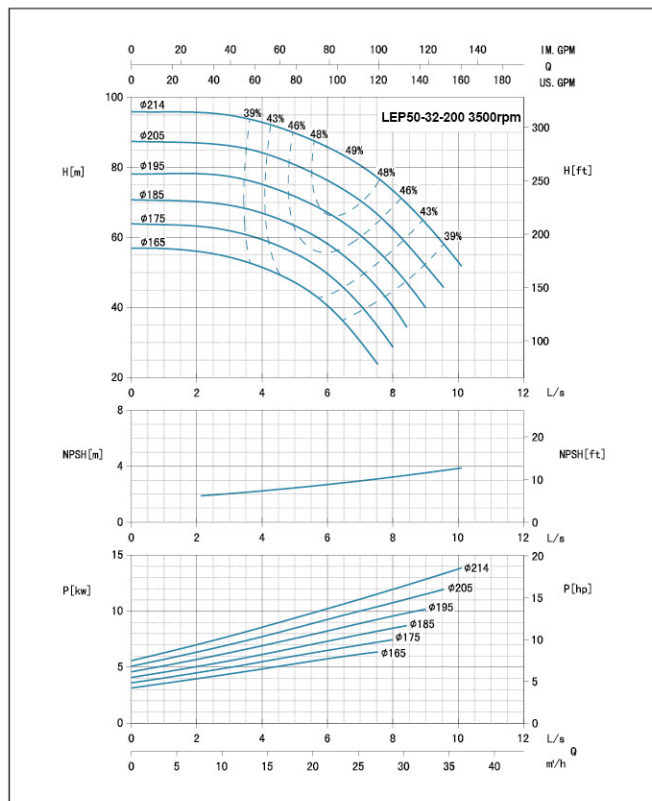
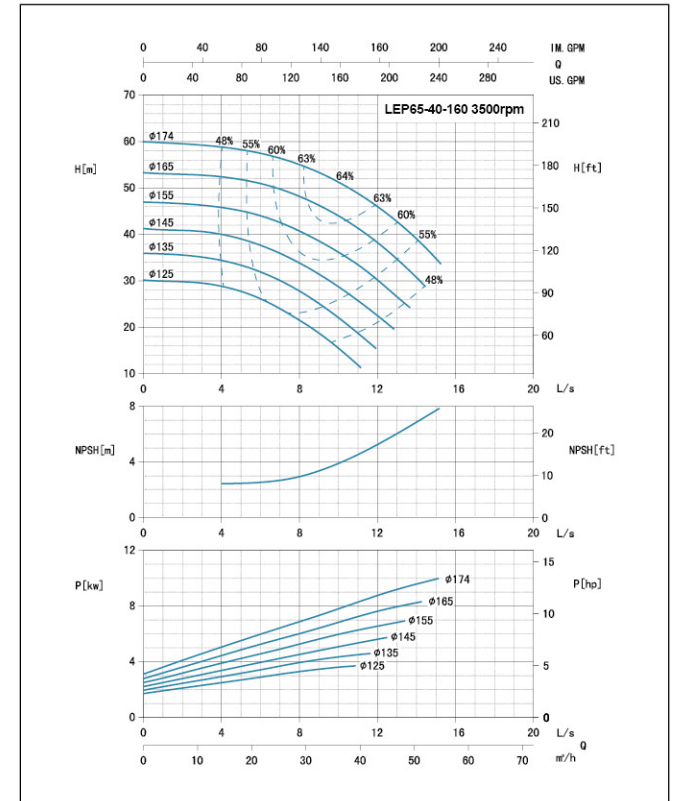
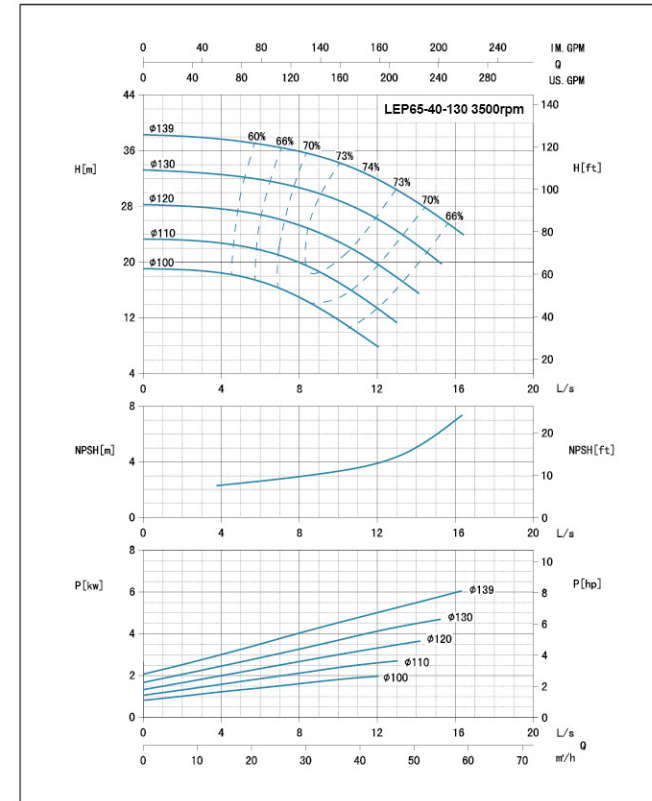
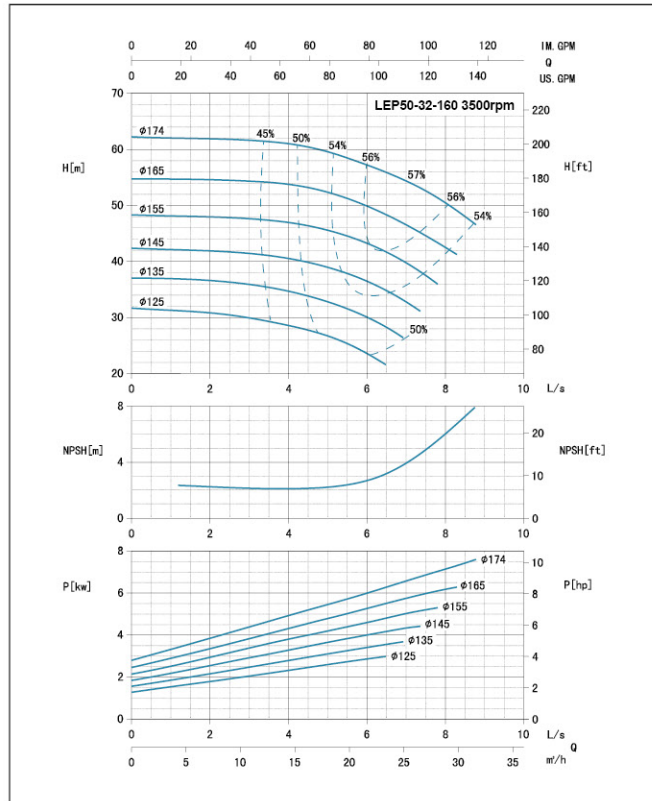
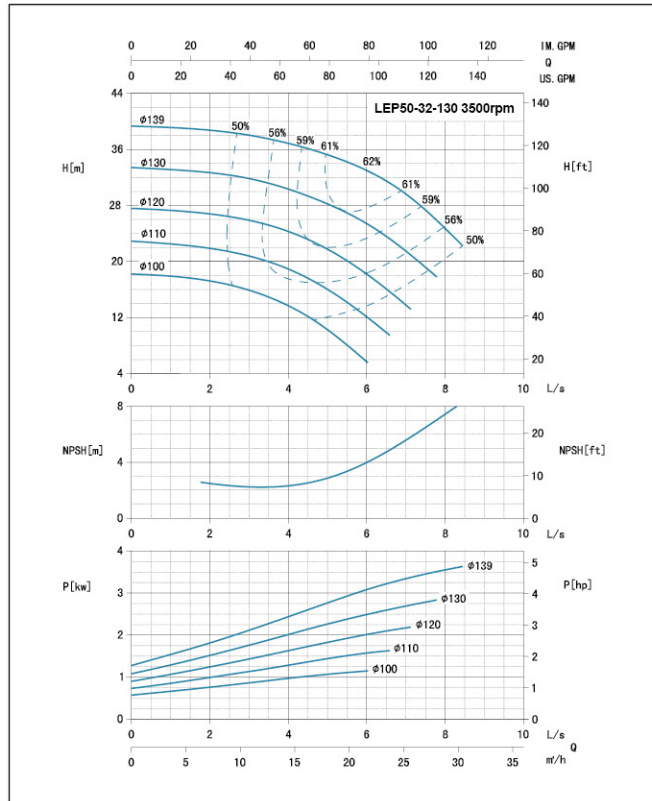

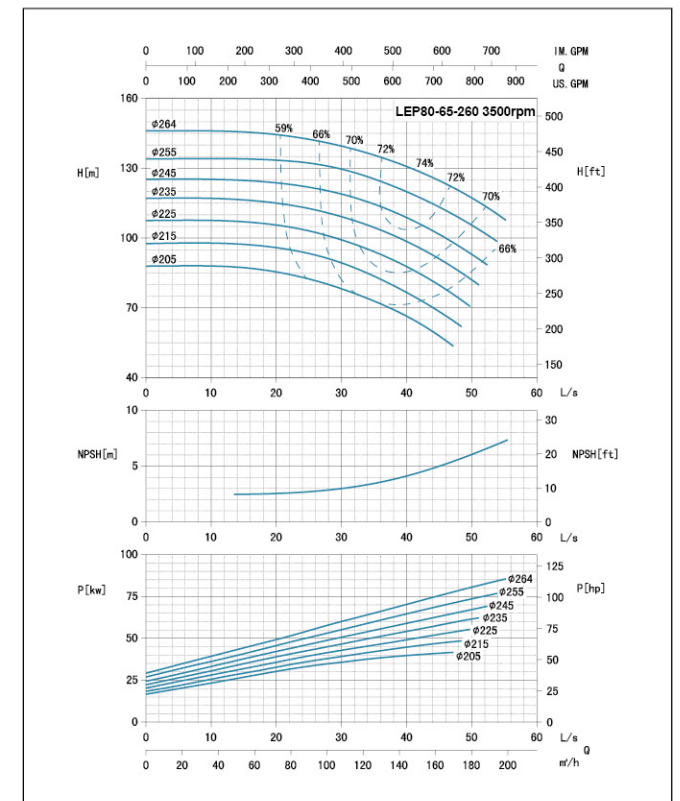
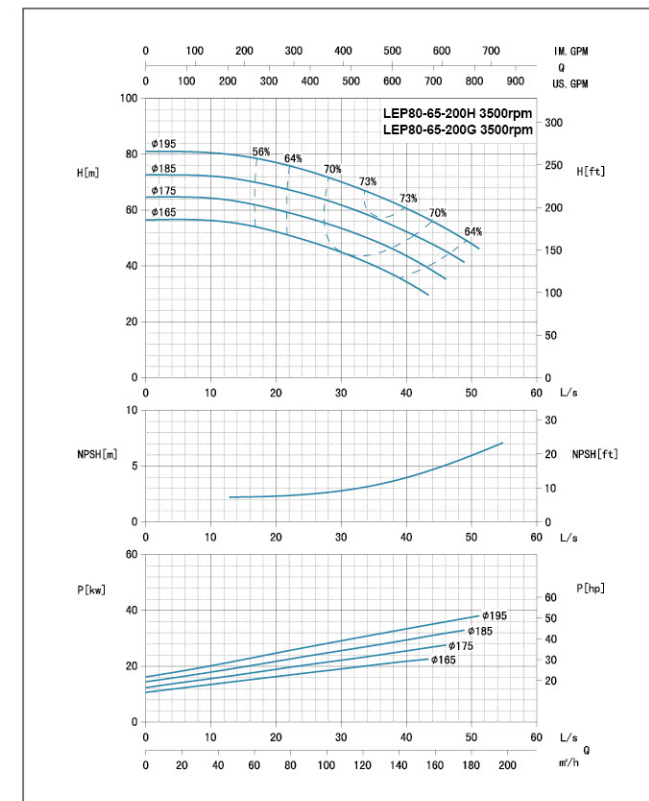
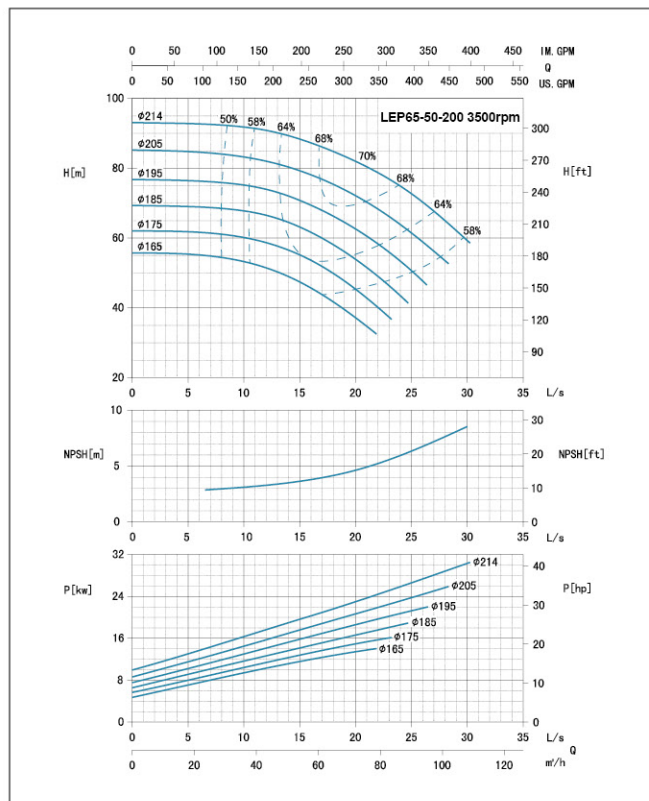
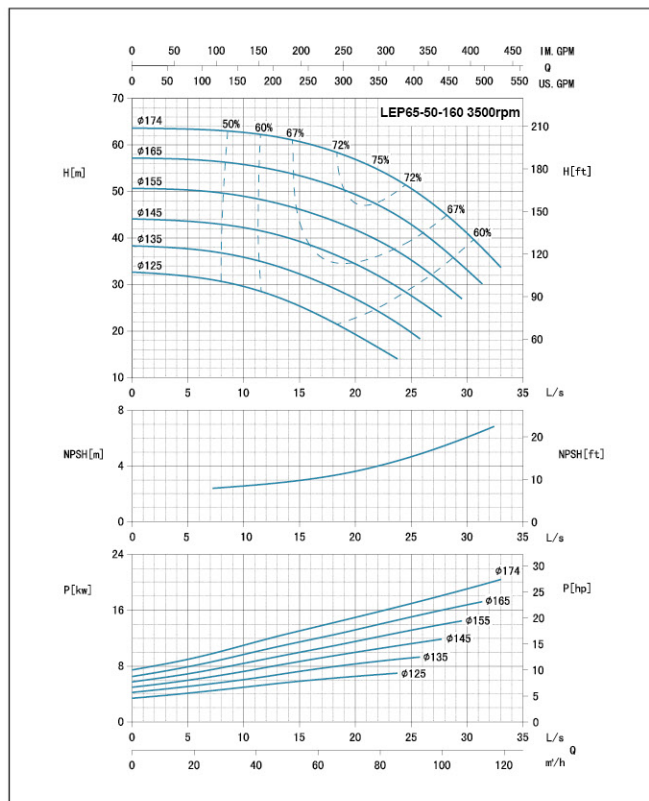
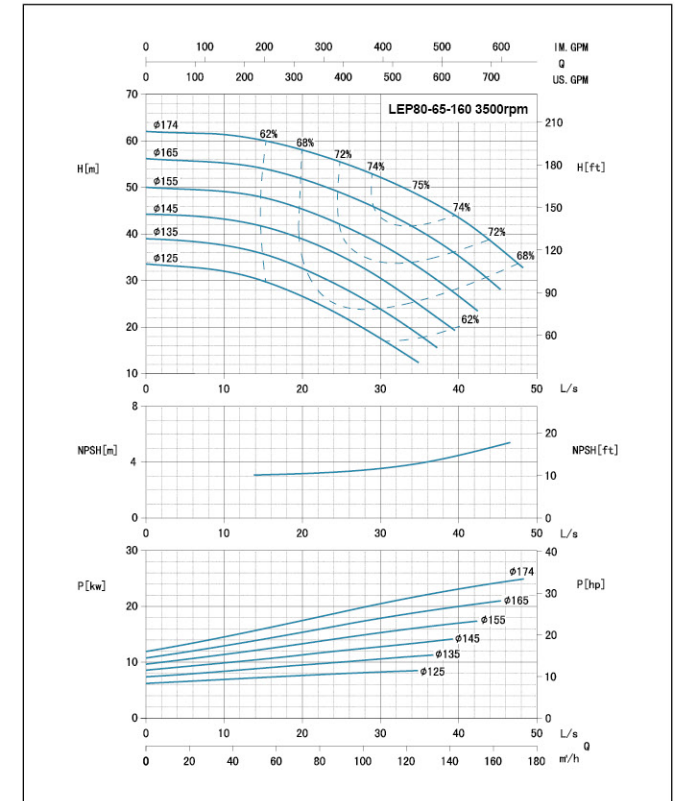
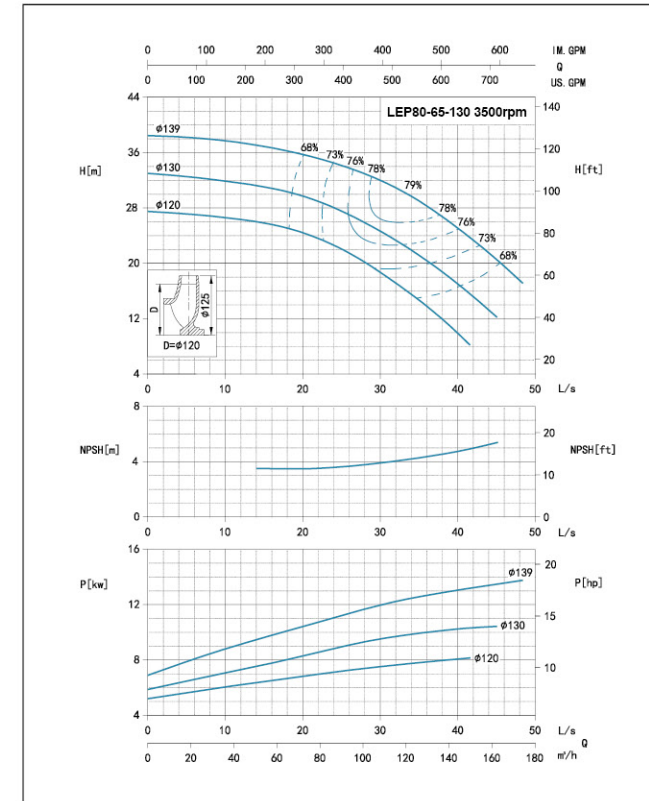
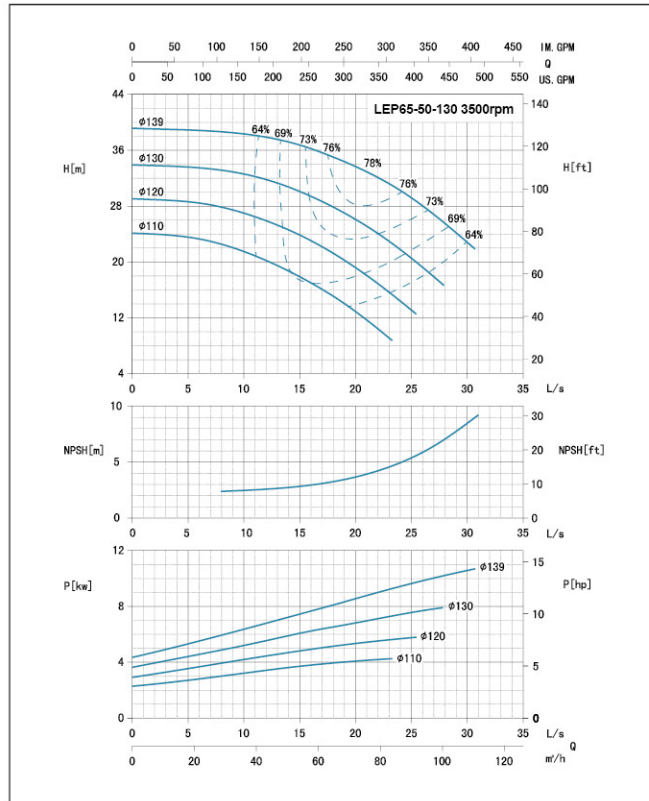
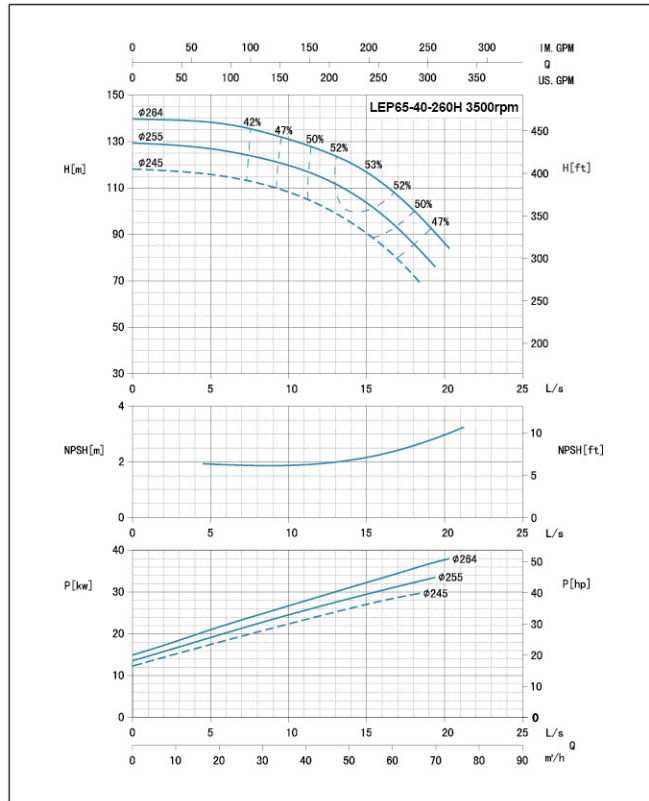

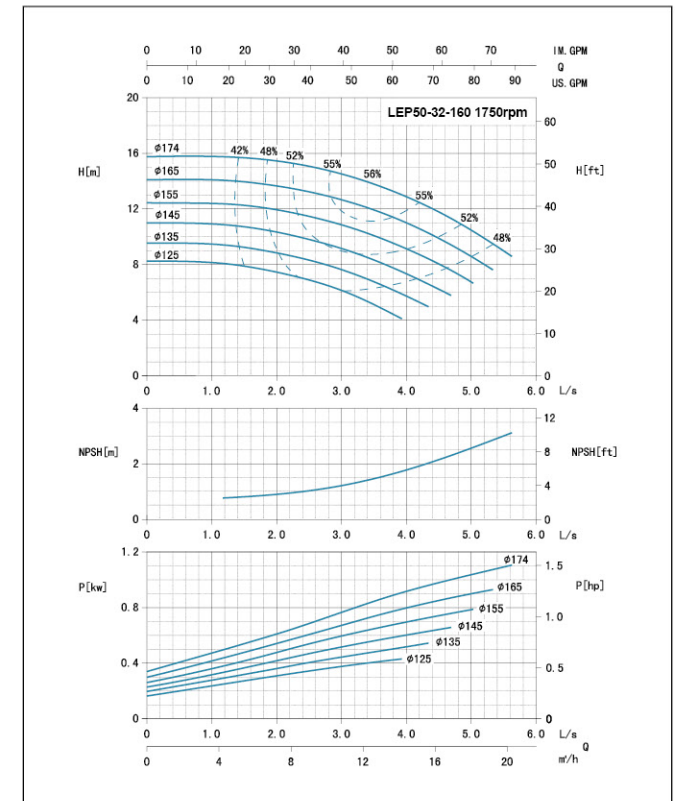
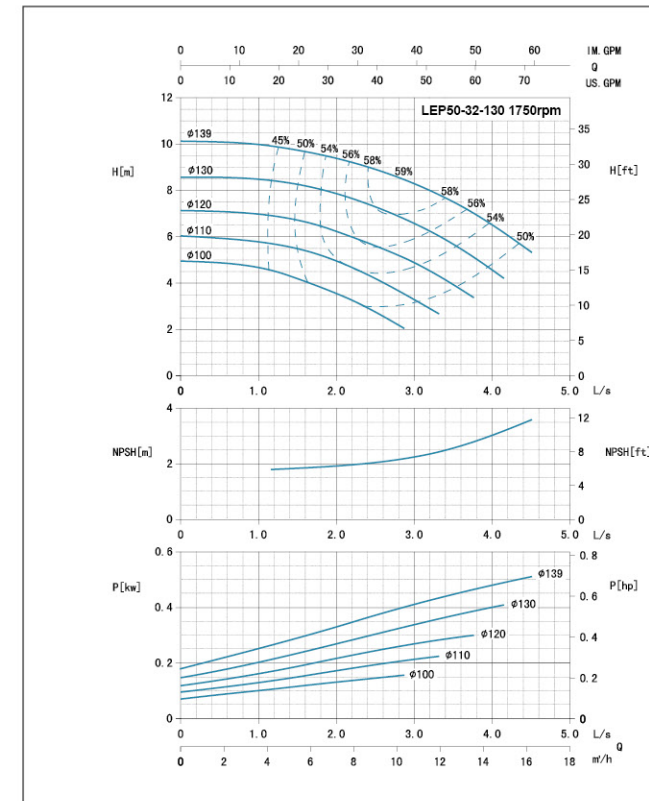
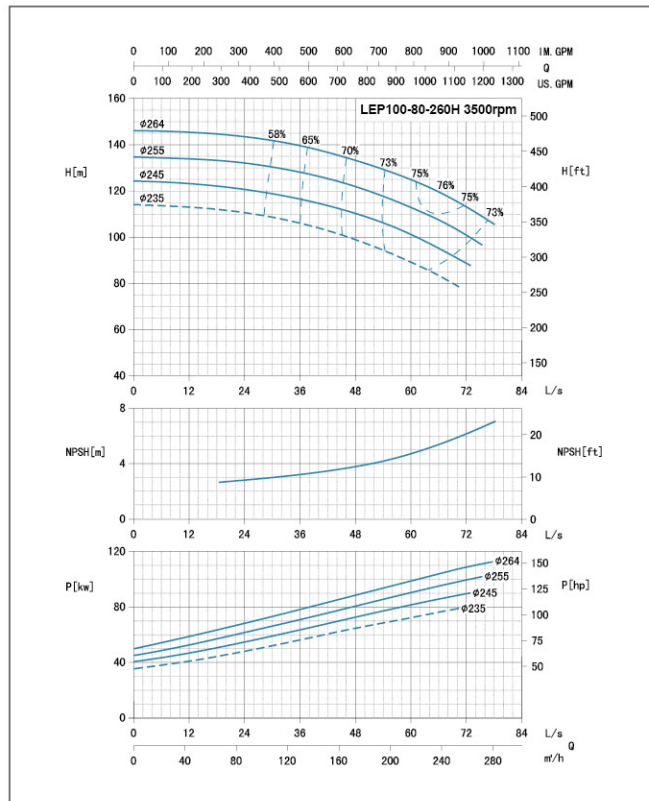
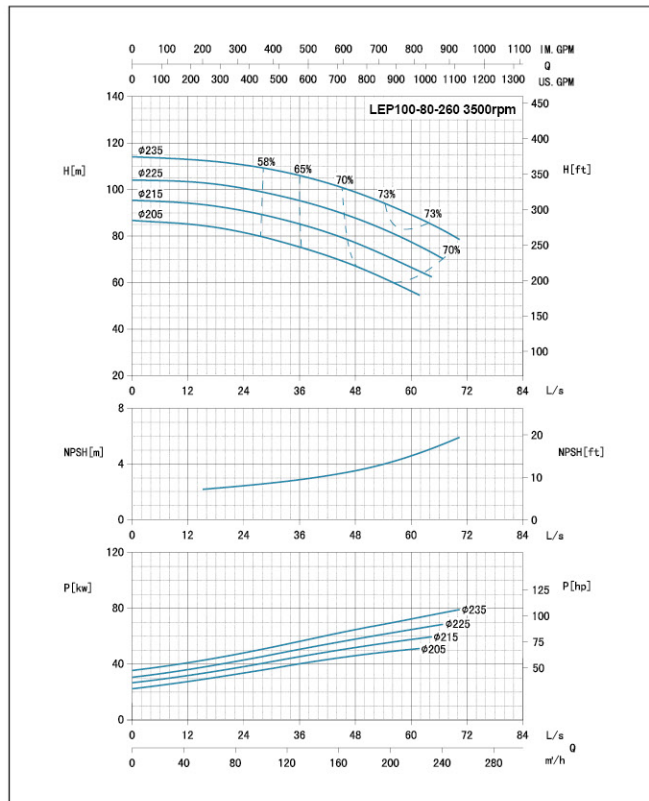
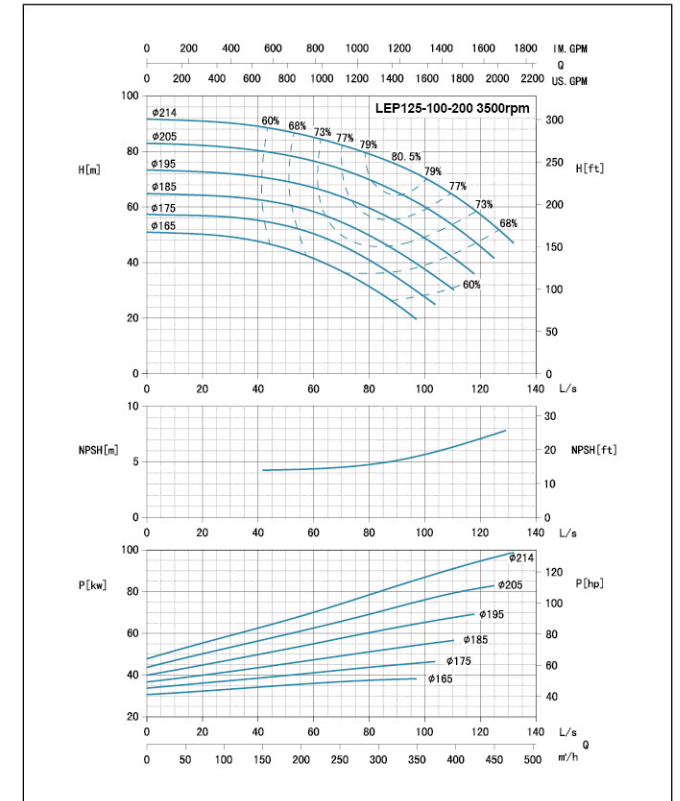
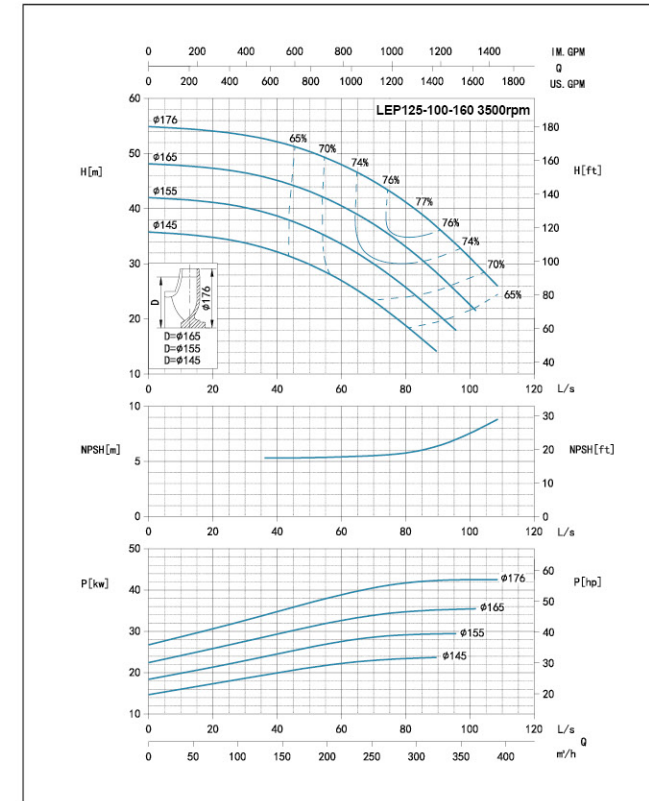
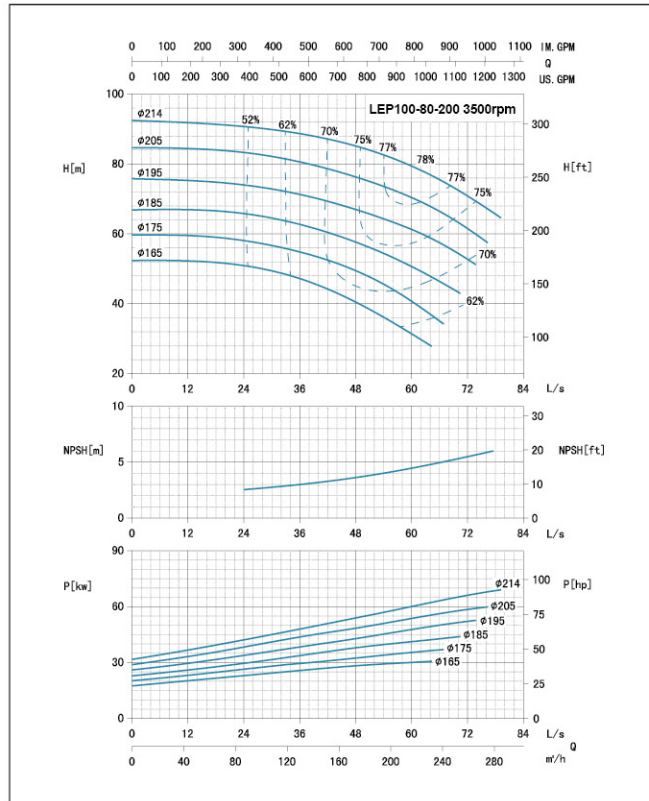
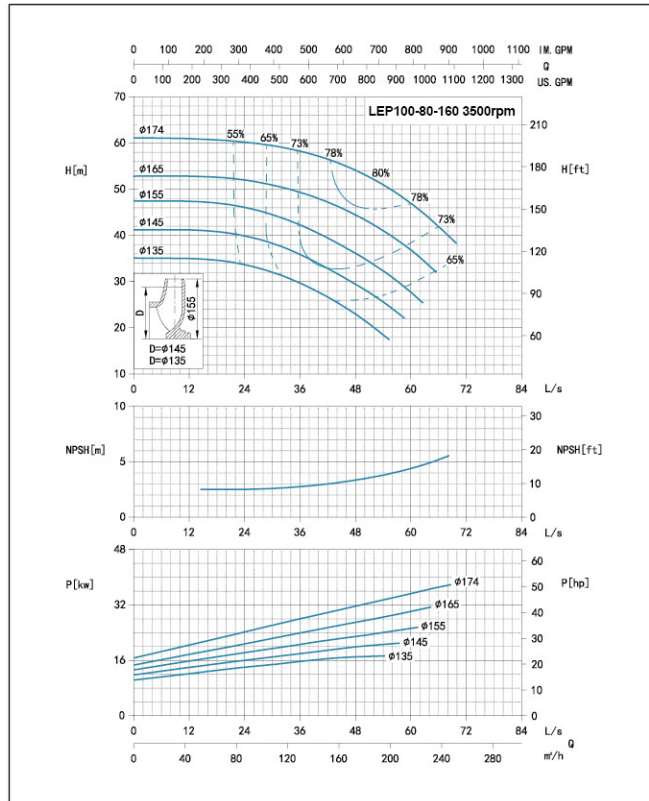

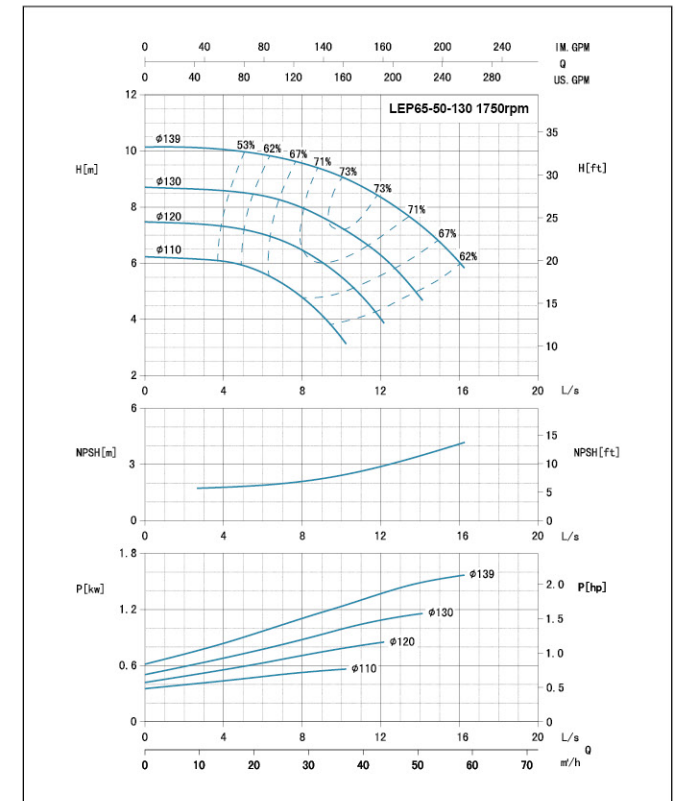
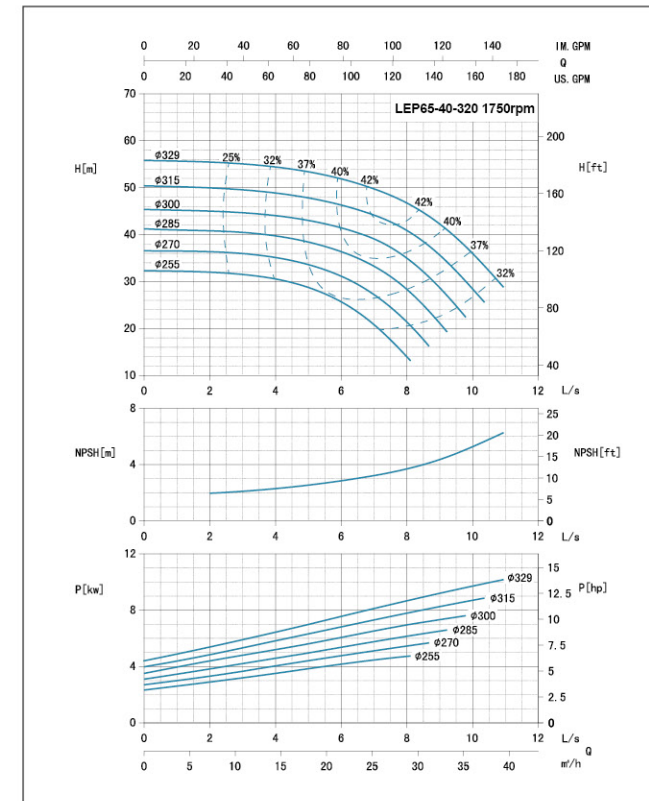
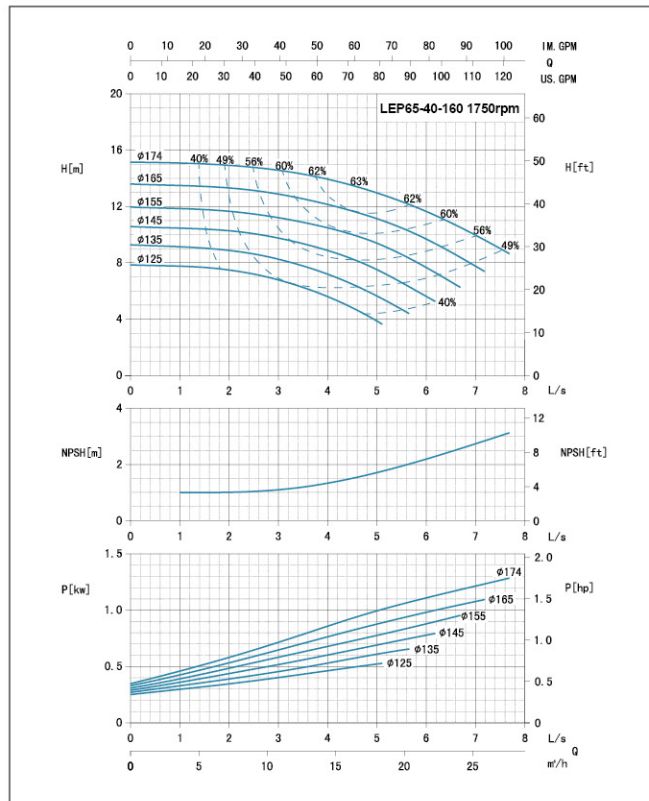
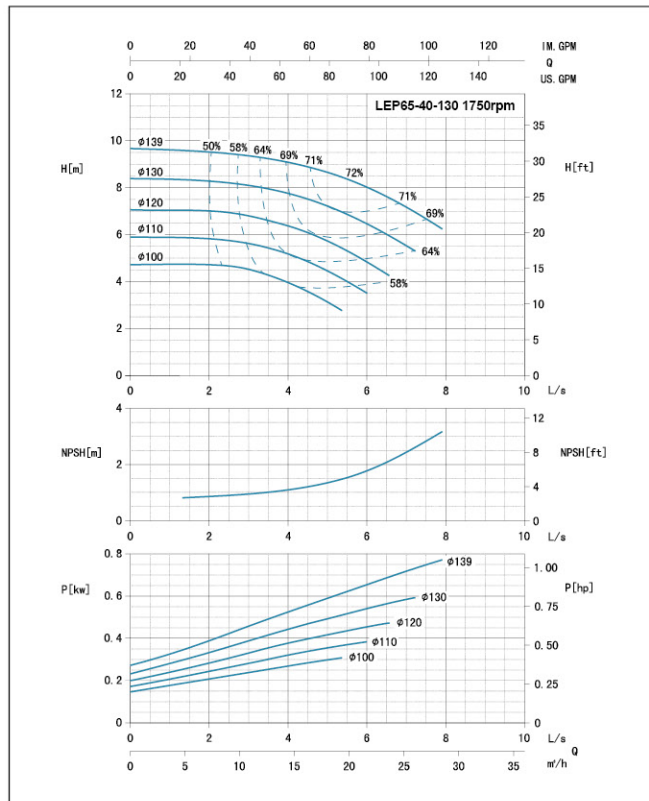
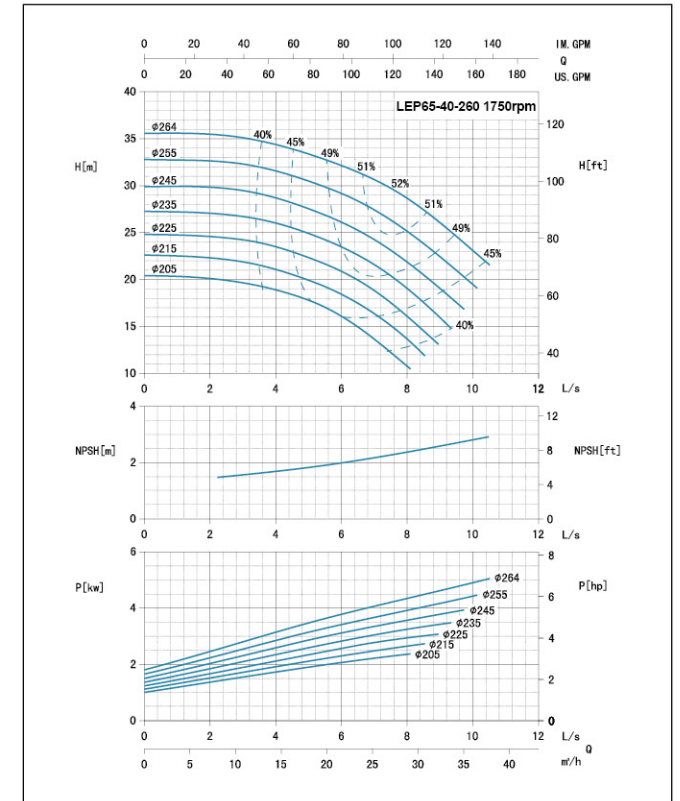
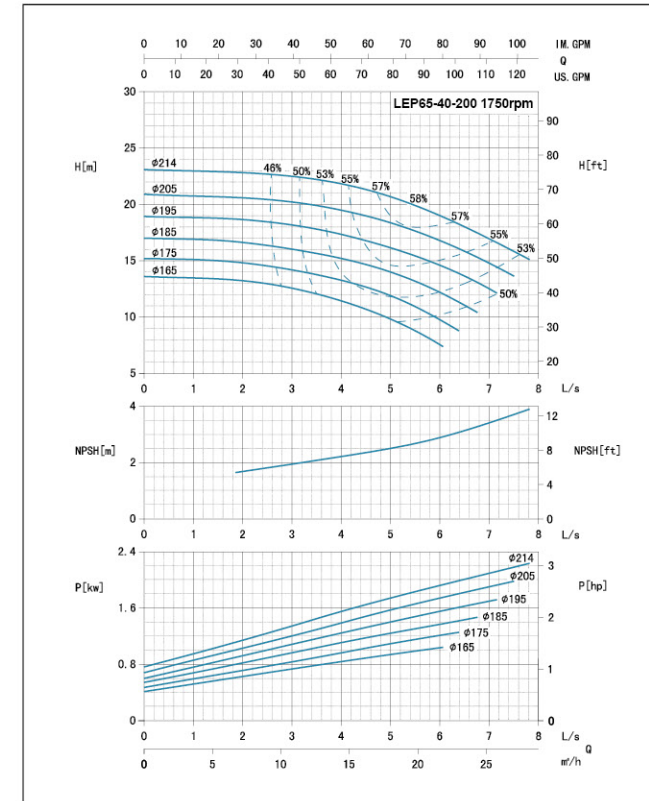
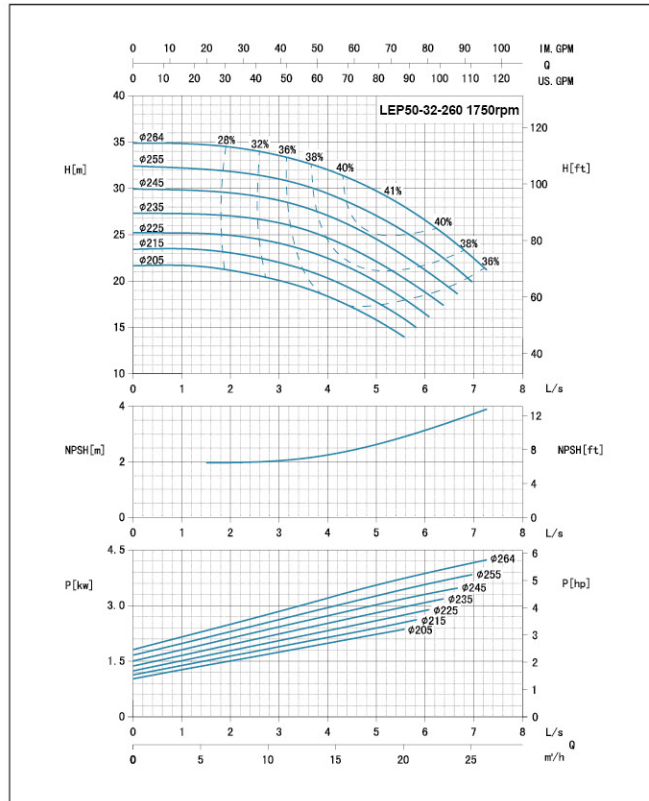
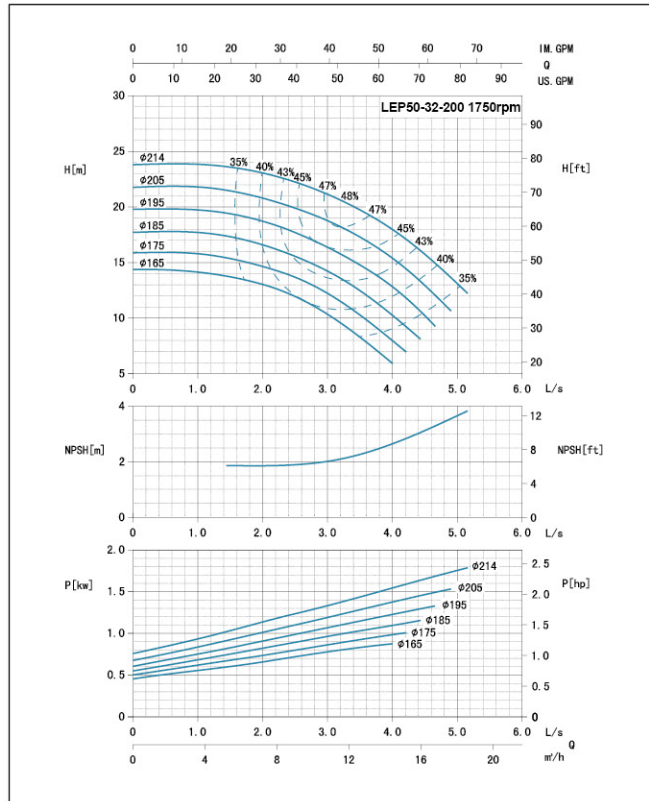

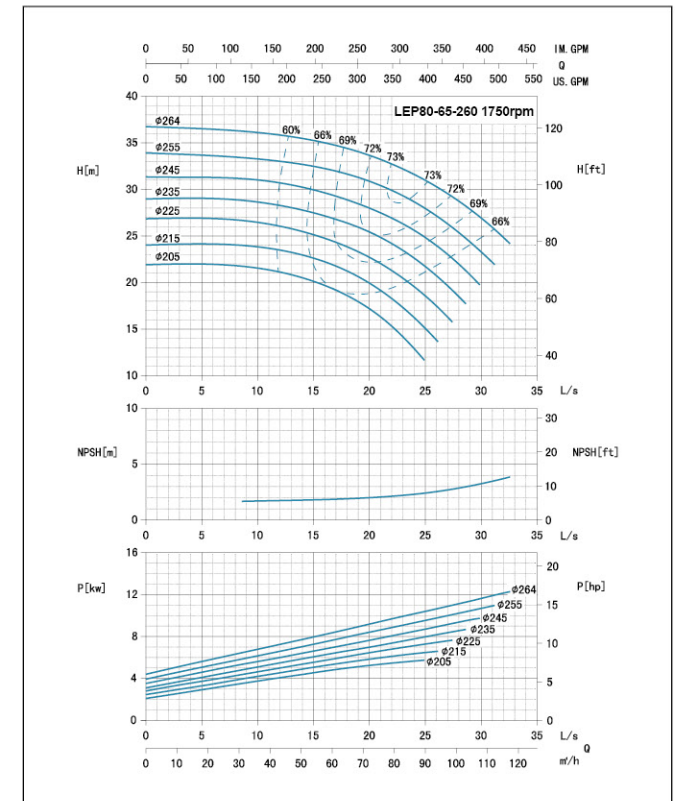
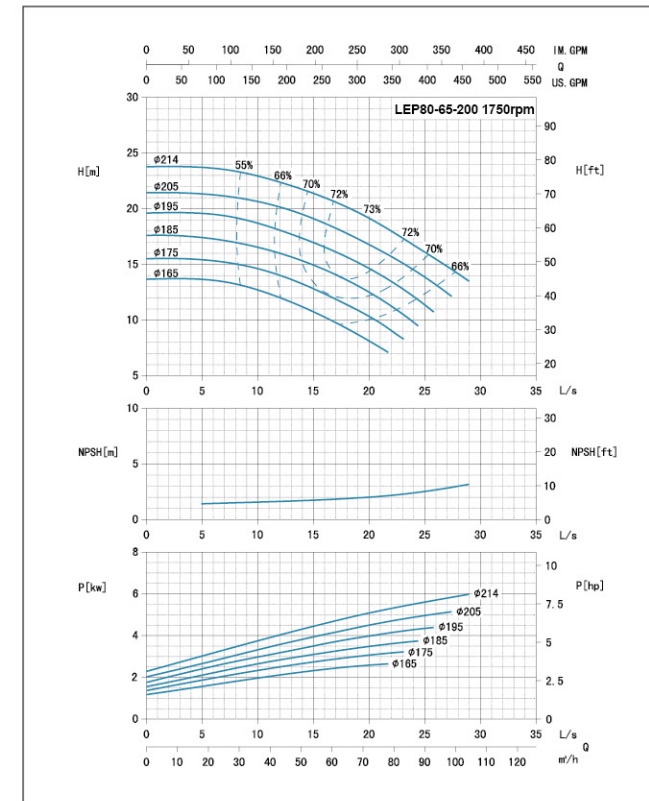
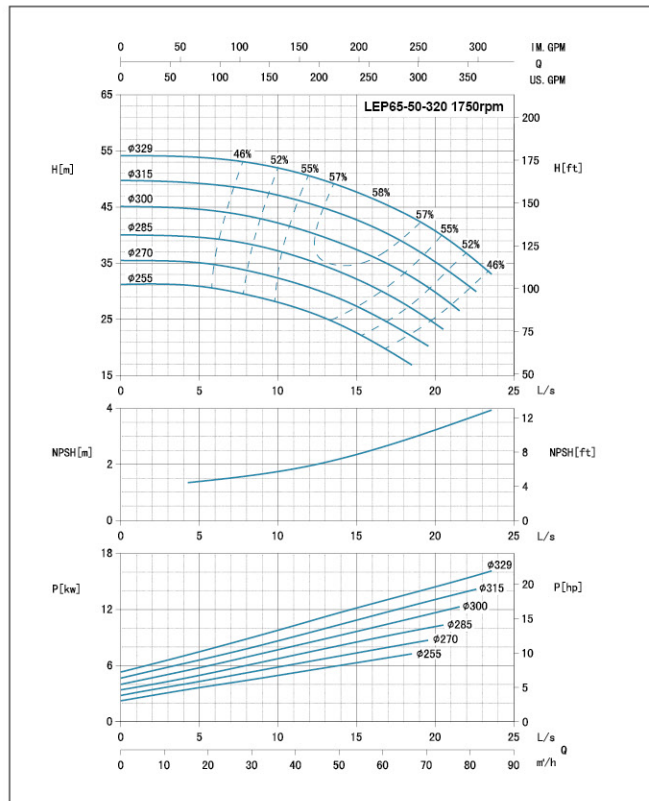
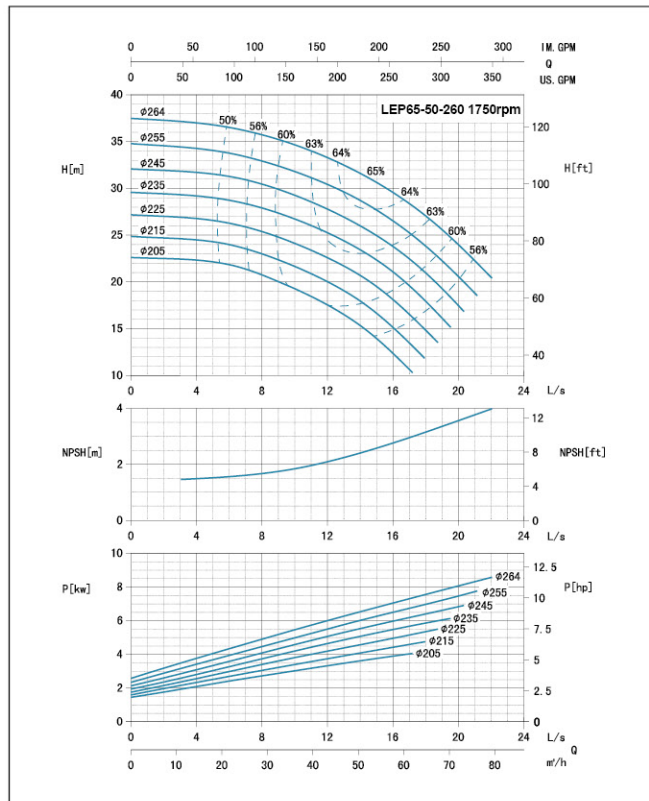
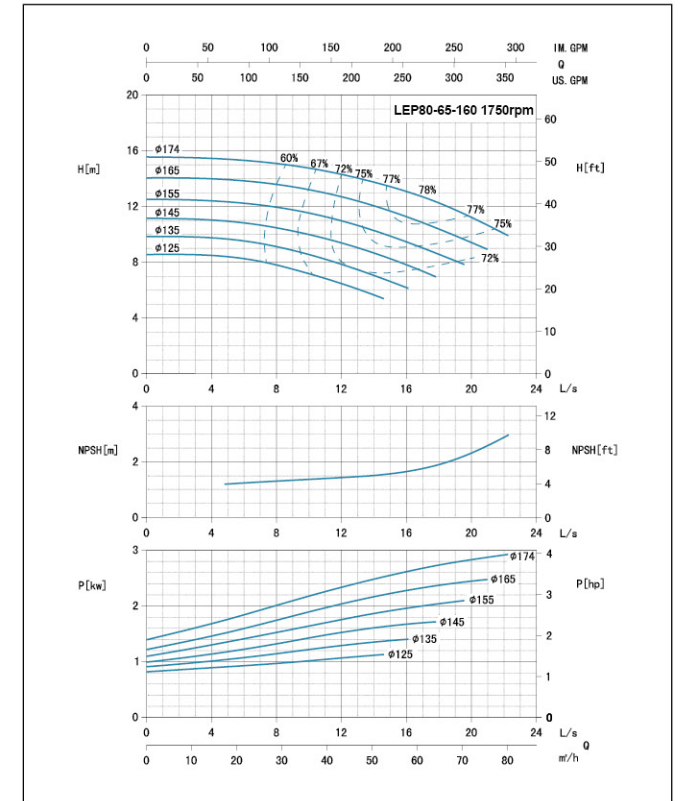
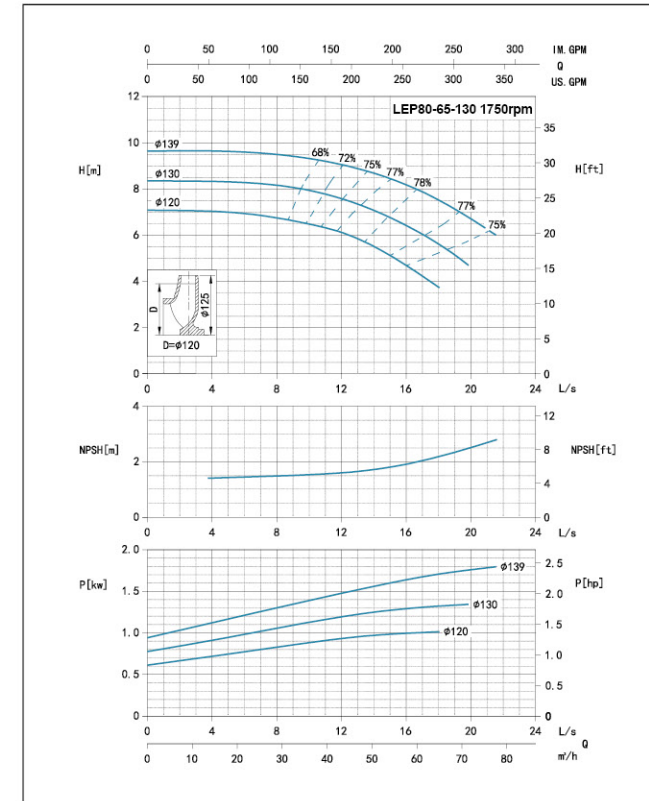
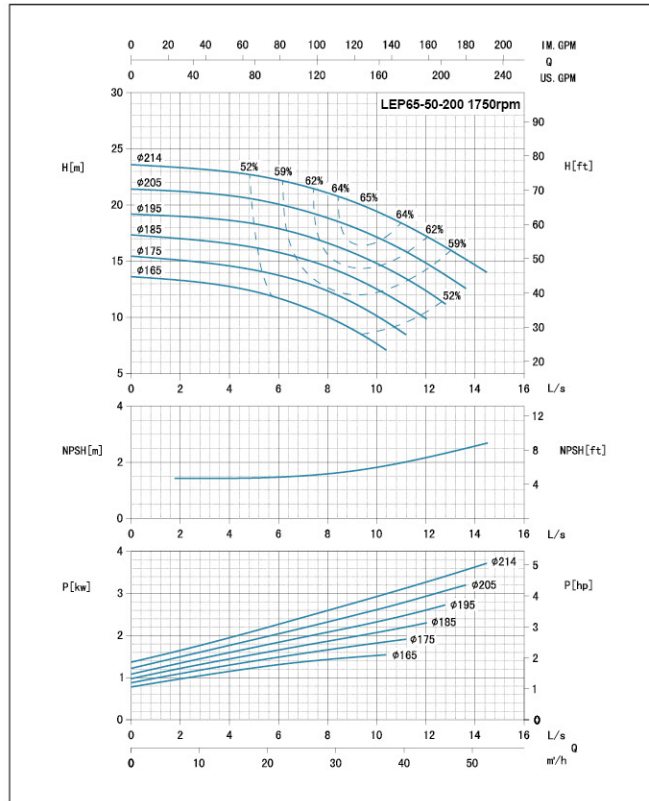
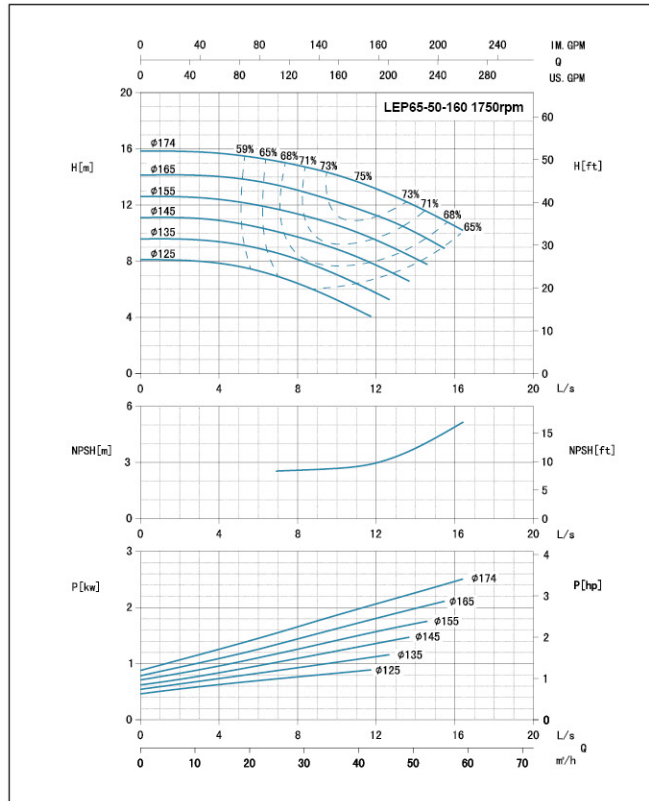

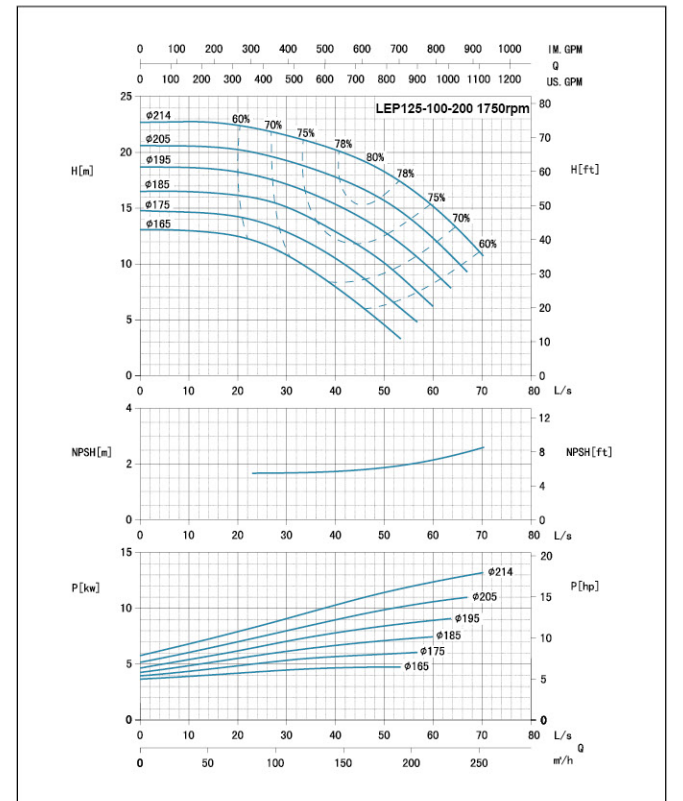
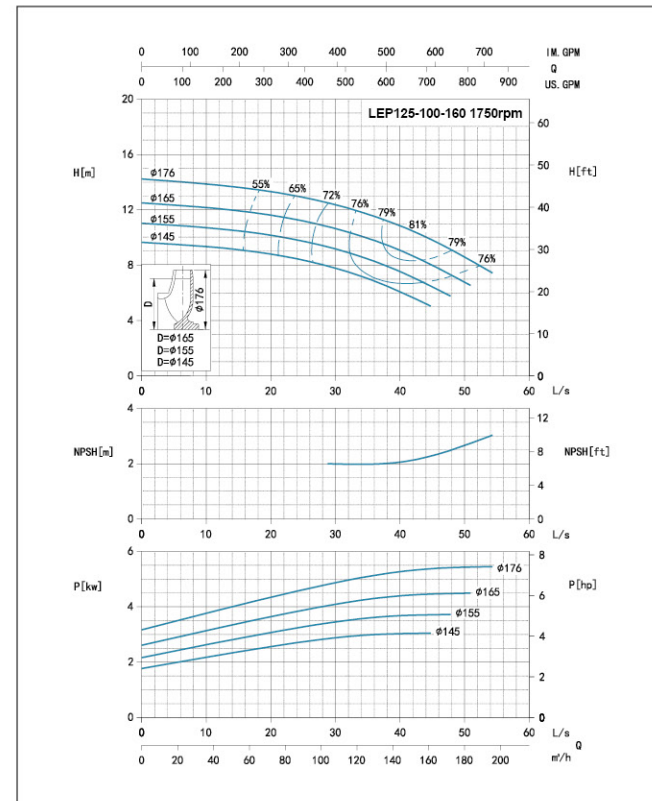
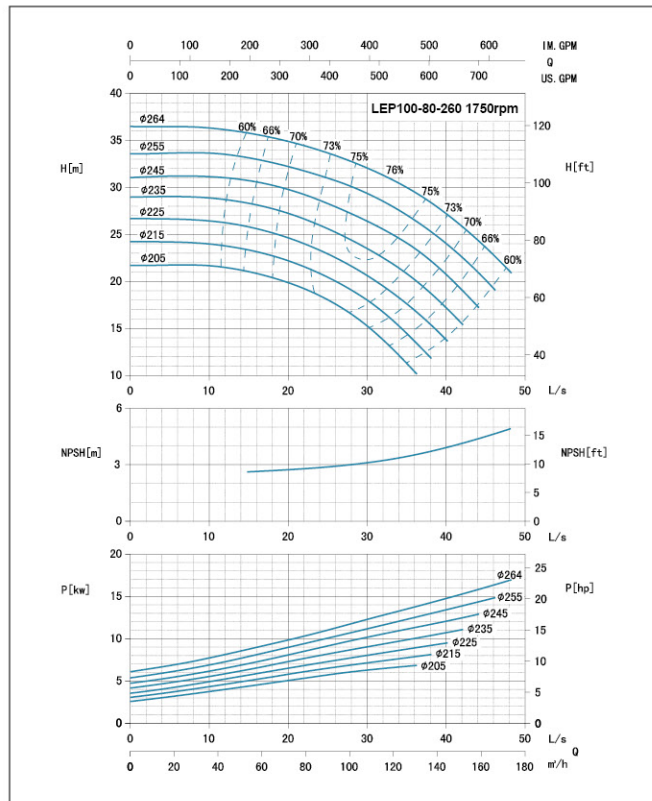
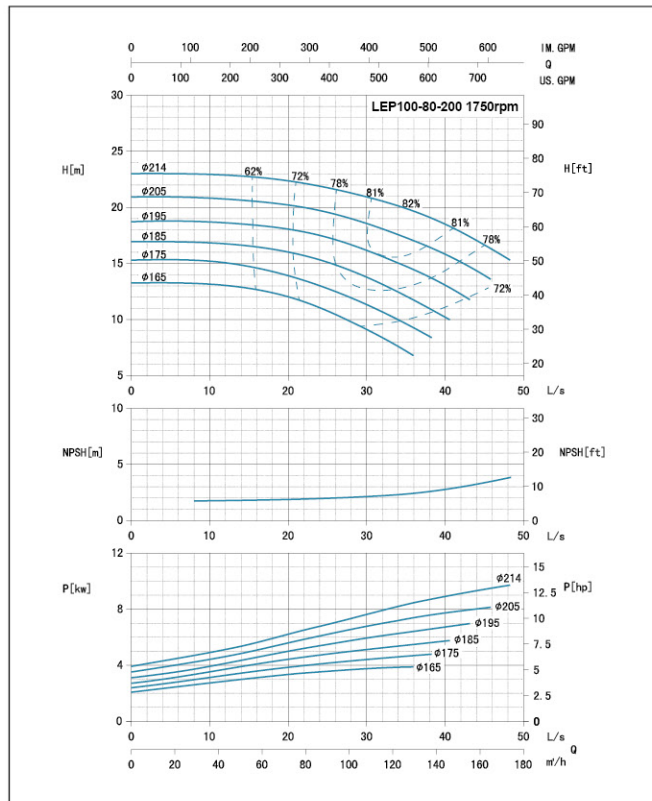
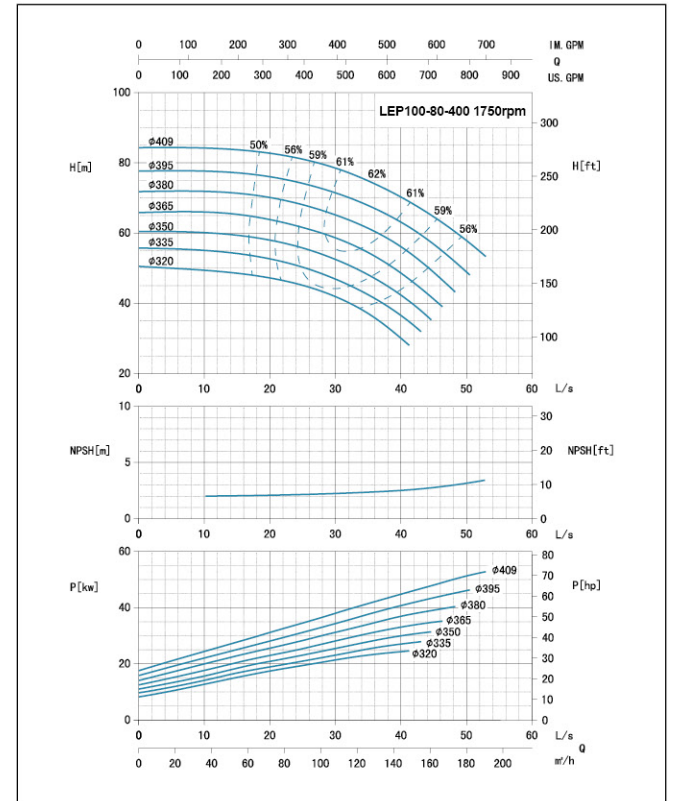
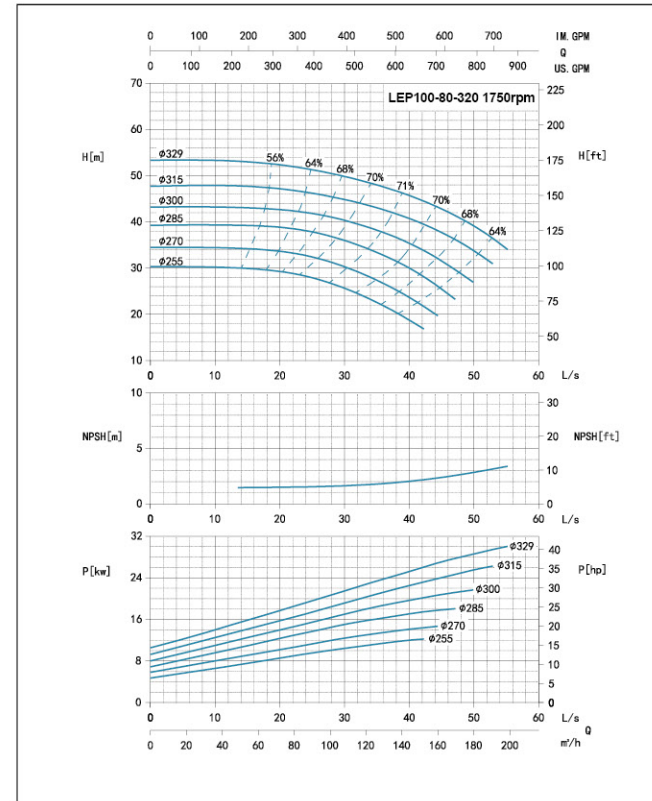
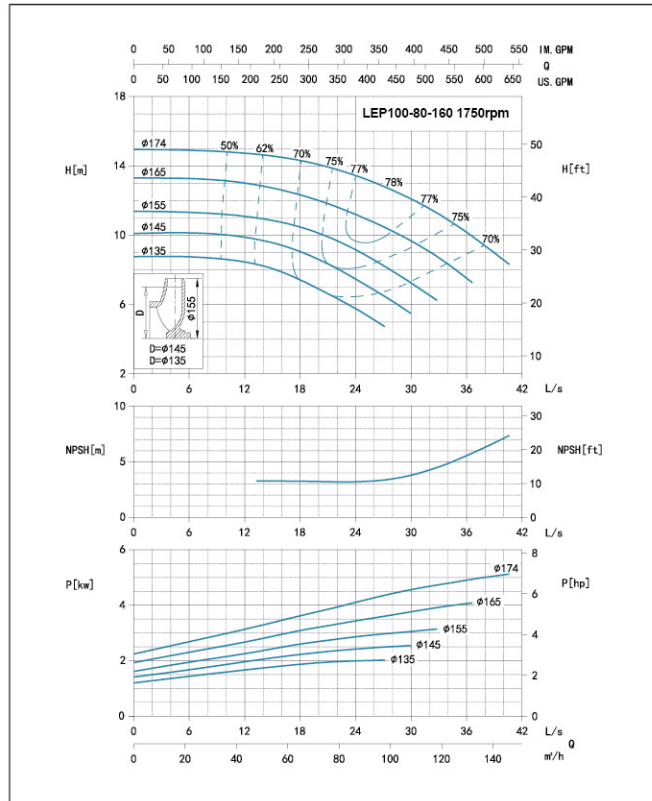
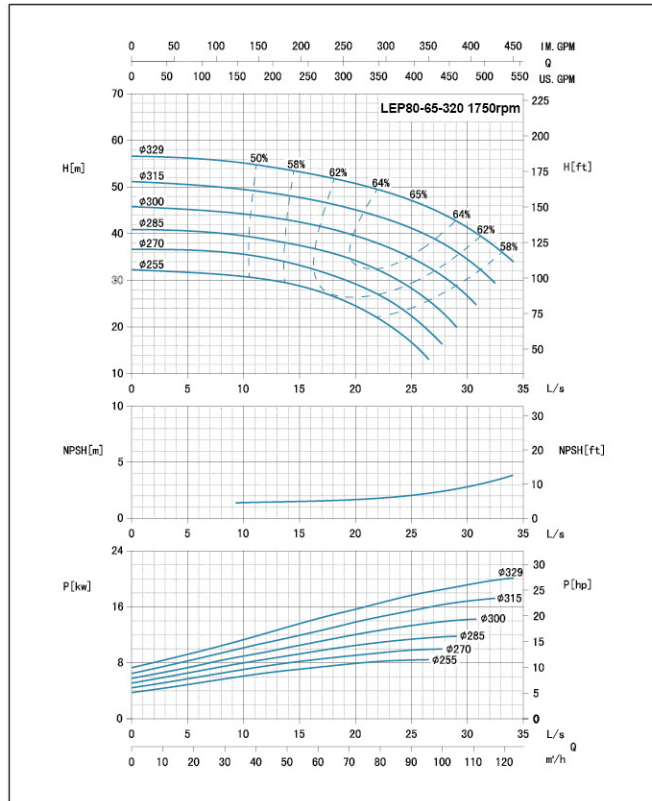

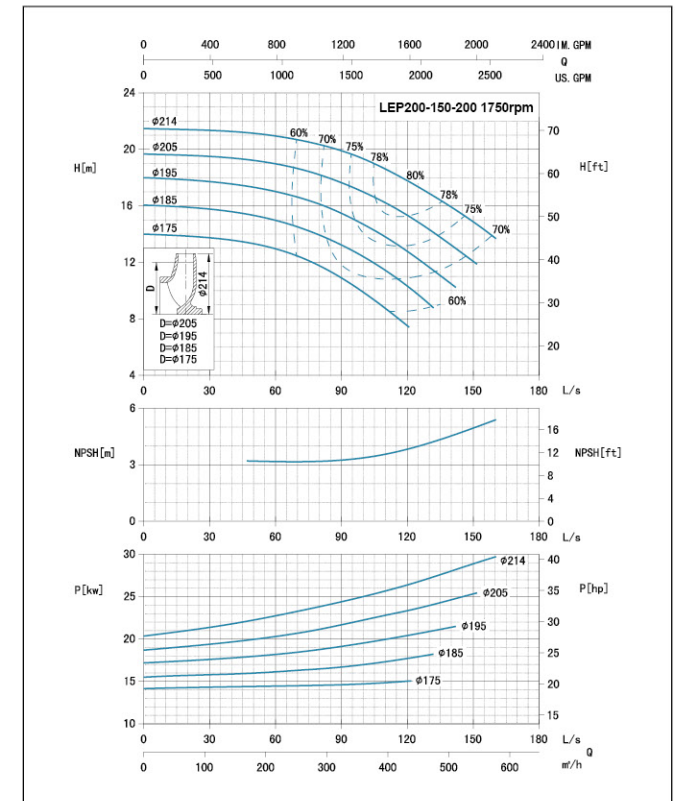
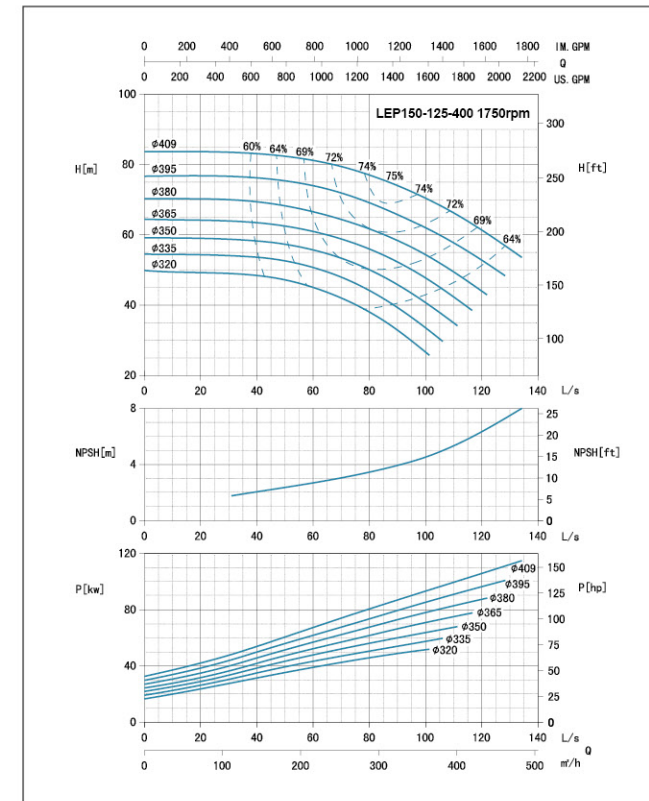
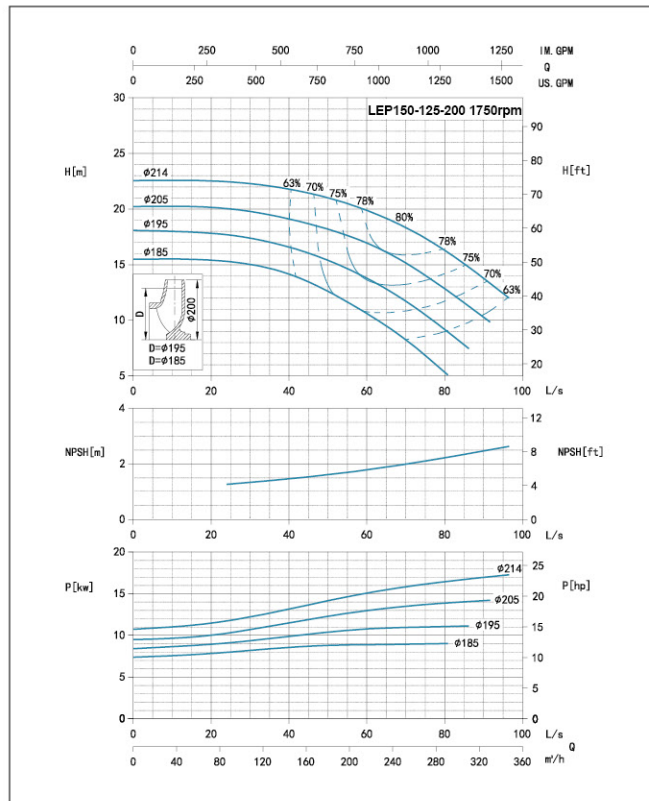
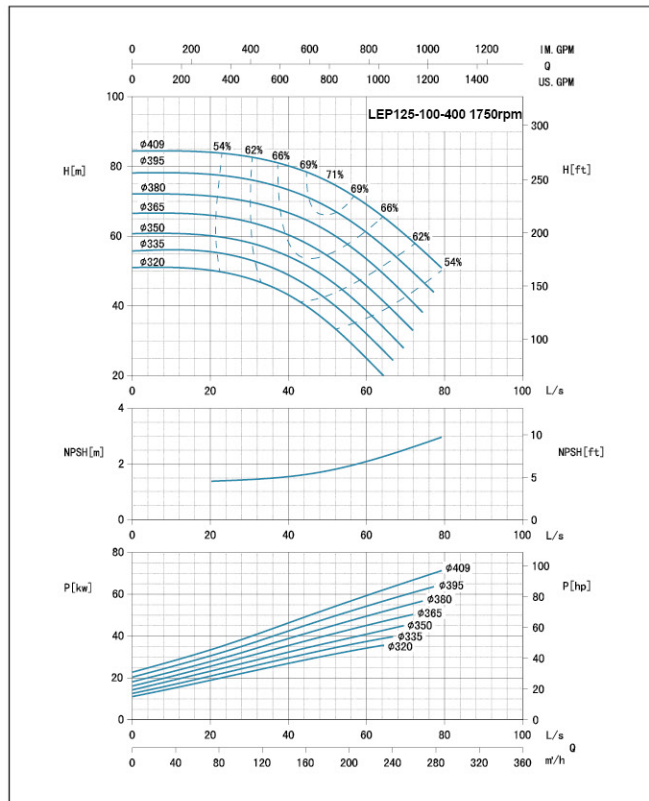
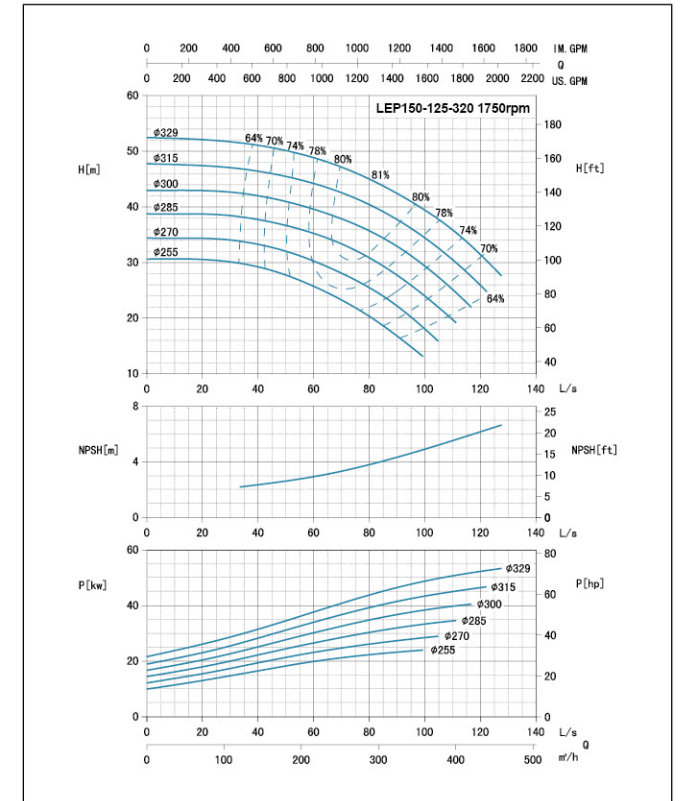
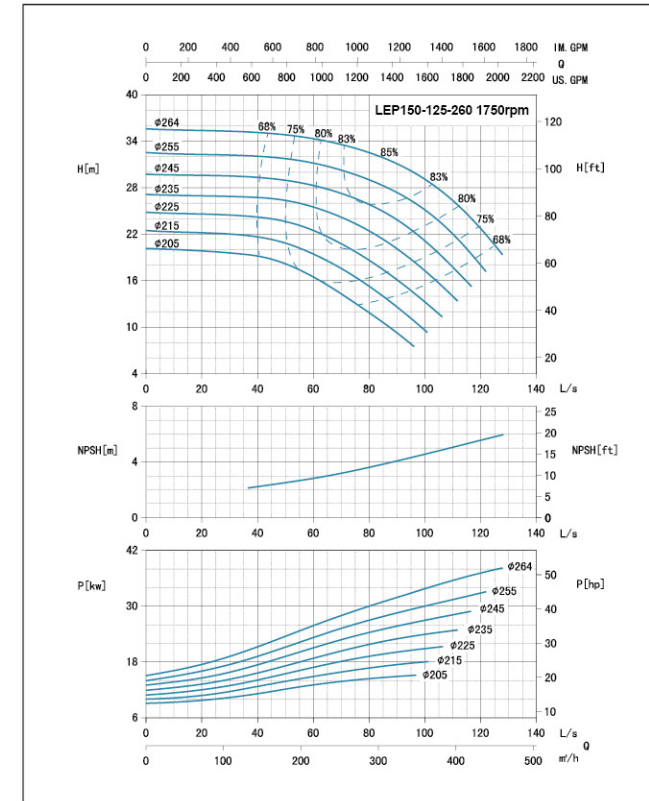
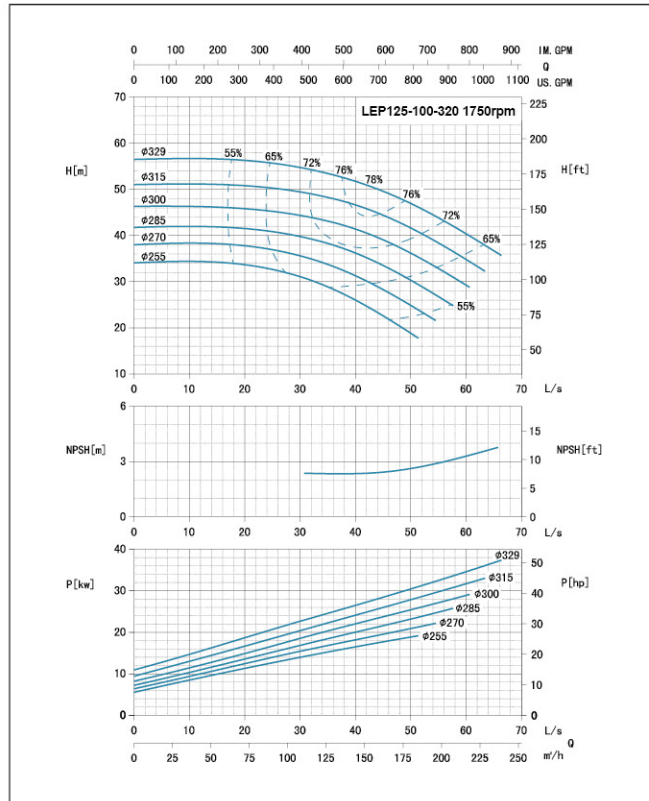
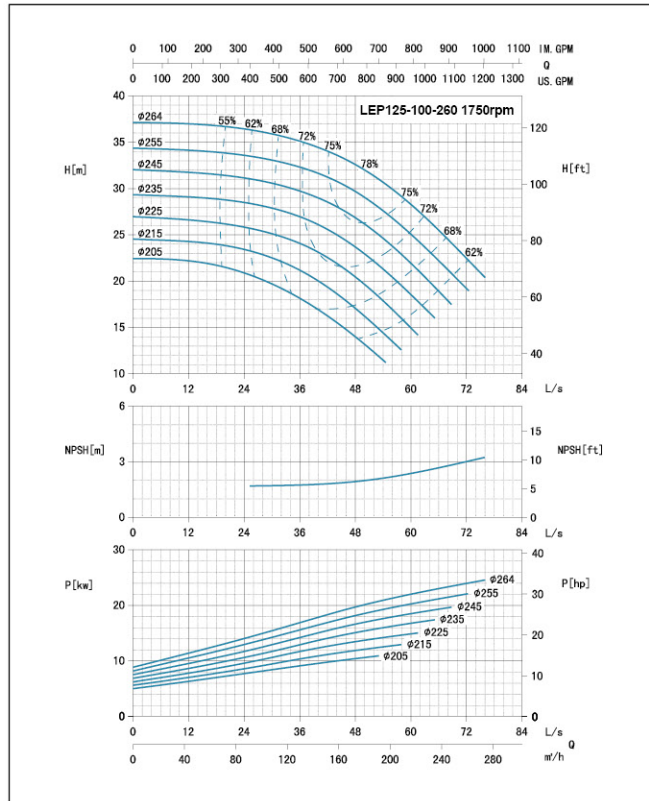

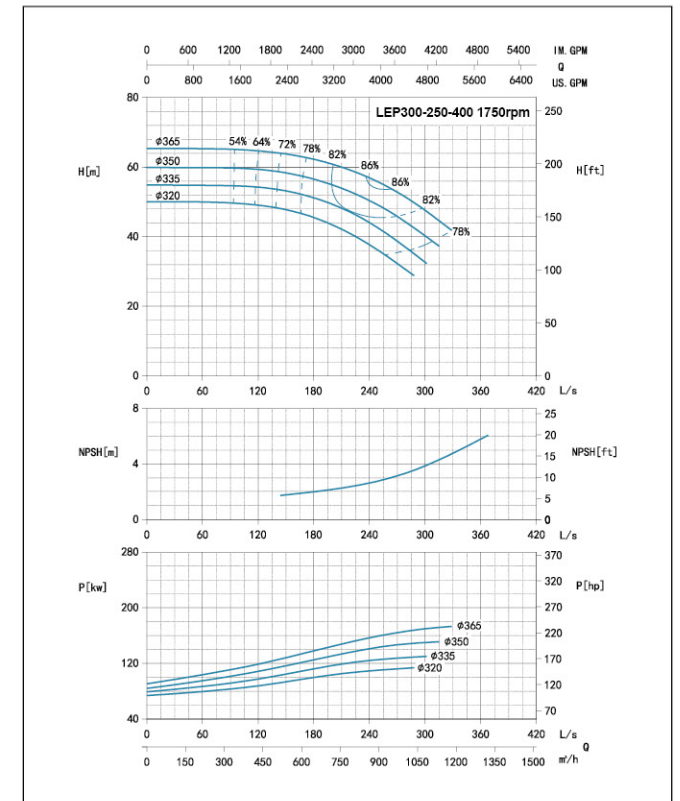
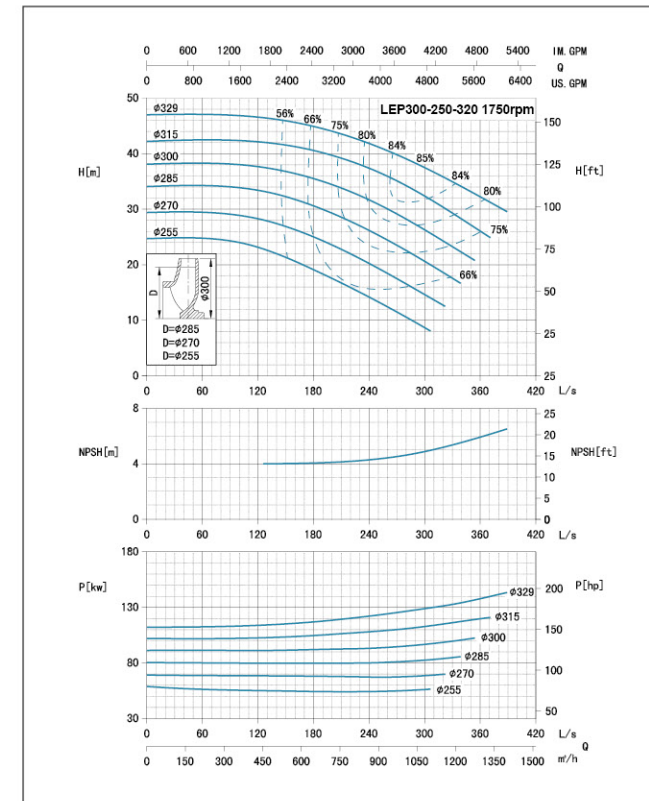
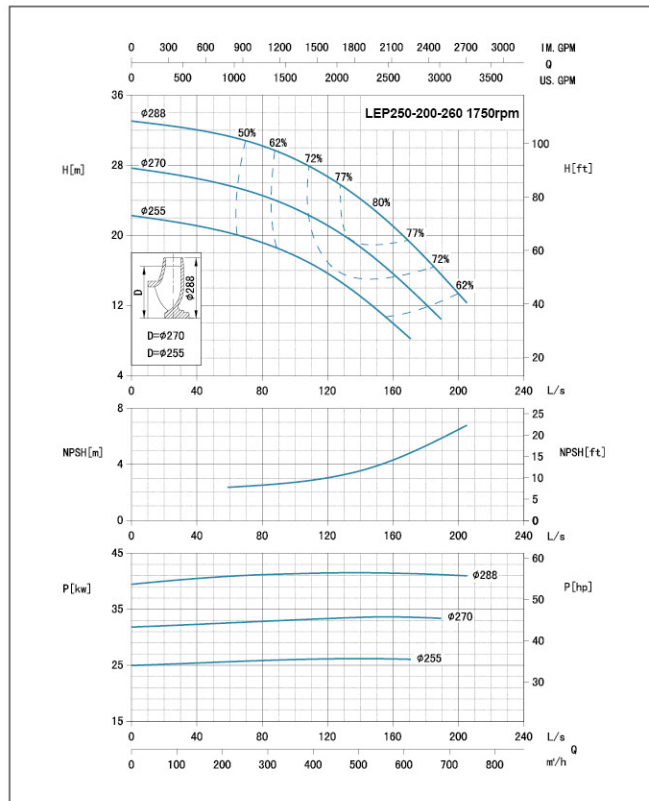
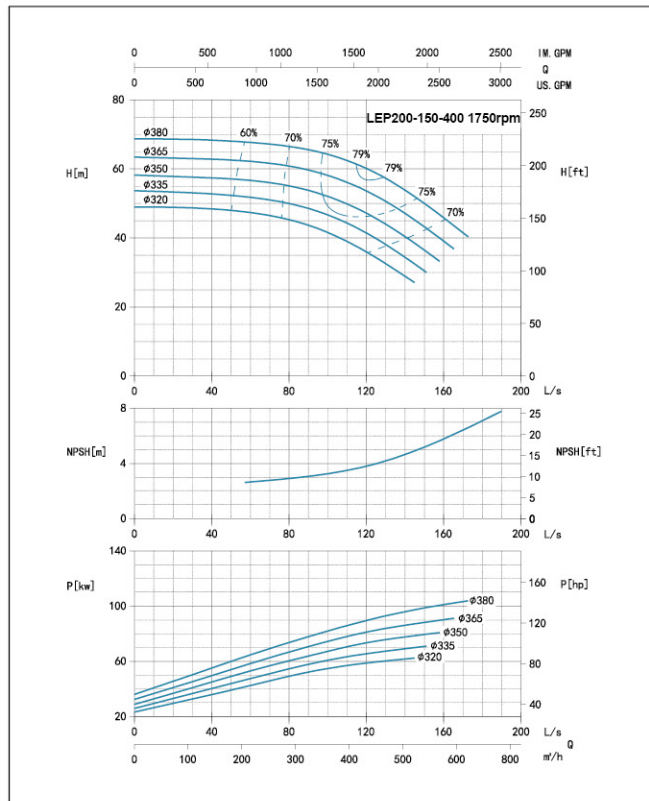
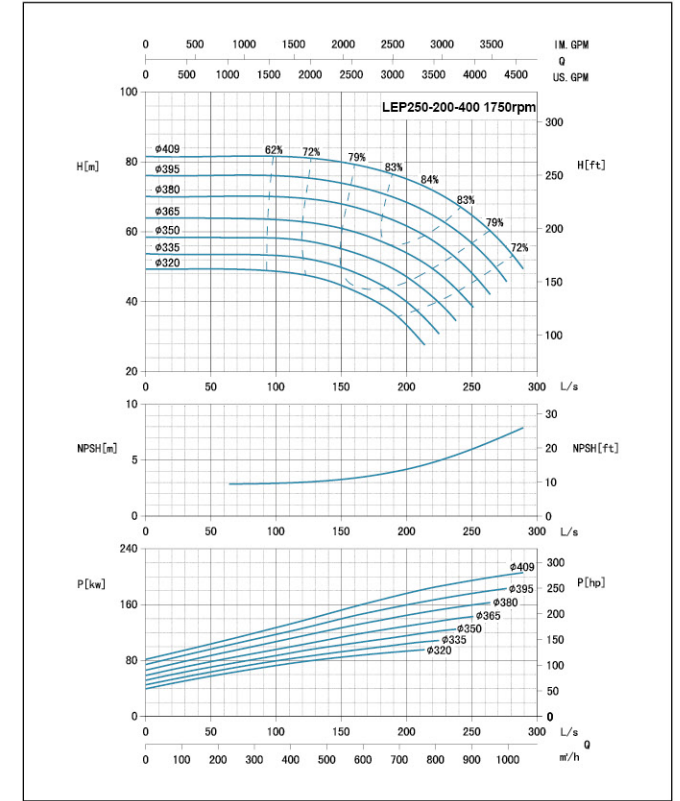
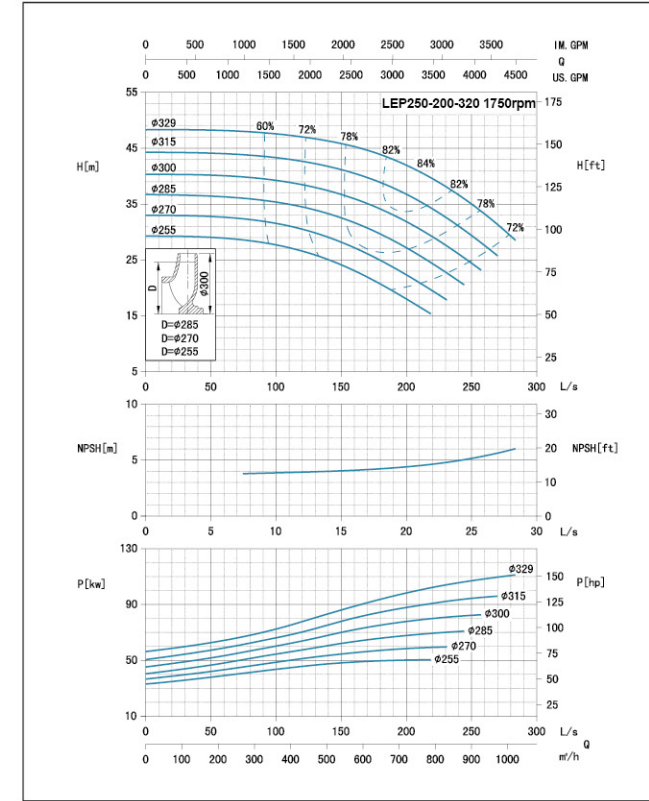
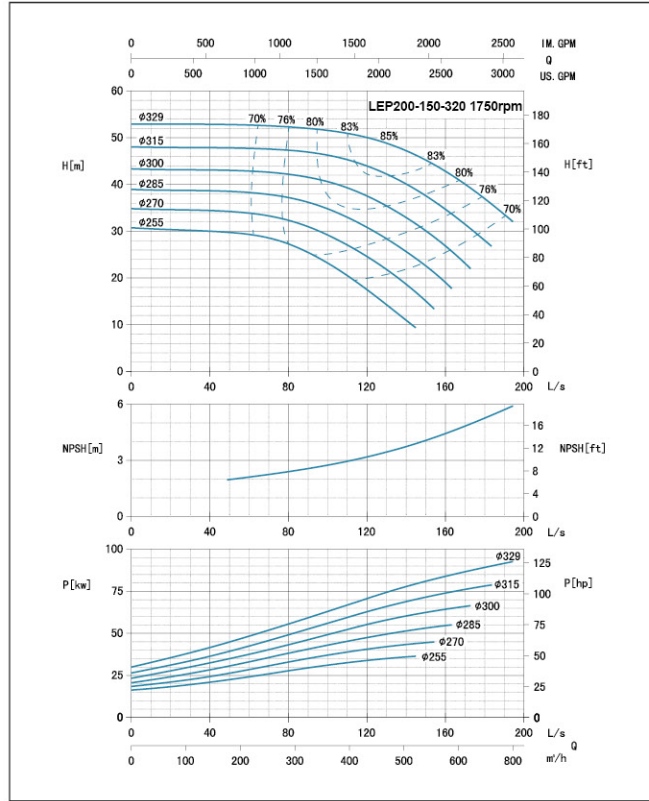
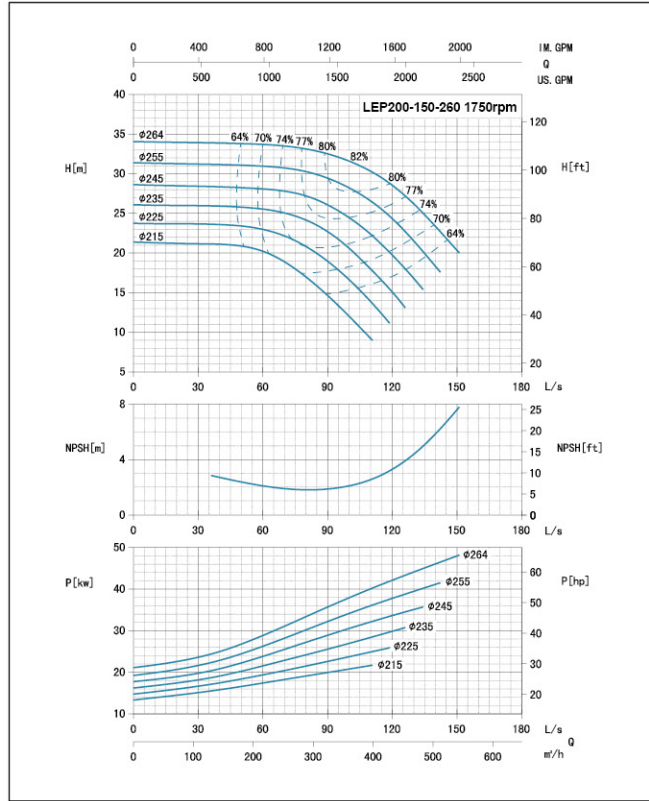

Pump Range



● Peripheral Pump



● Self-Priming Peripheral Pump



● Jet Pump



● Jet Pump for Deep Wells



● Centrifugal Pump



● Multistage Centrifugal Pump



● Self-Priming Centrifugal Pump



● Stainless Steel Multistage Centrifugal Pump



● Stainless Steel Centrifugal Pump



● Submersible Pump

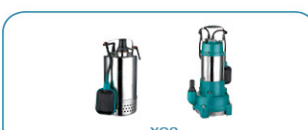

● Stainless Steel Submersible Pump



● Stainless Steel Submersible Sewage Pump



● Flexible Shaft Pump



● Domestic Lifting Station



● Pool Pump



● Garden Submersible Pump



● Garden Jet Pump



● Pressure Booster System



● Fountain Pump



● Standard Centrifugal Pump

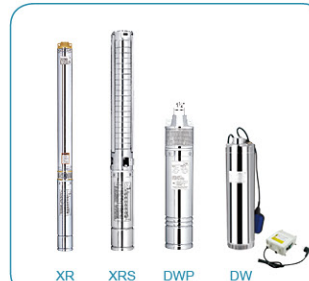

● Submersible Borehole Pump



● Gasoline/Diesel Engine Pump



● Booster Pump/Circulation Pump

Pump Range



● Submersible Sewage Pump



● Submersible Sewage Pump



● Submersible Dewatering Pump



● Submersible Slurry Pump

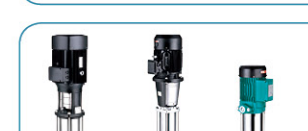

● Stainless Steel Vertical Multistage Pump



● Stainless Steel Horizontal Multistage Pump



● Semi-open Impeller Stainless Steel Centrifugal Pump



● Stainless Steel Standard Centrifugal Pump



● Pressure Booster System



● Vertical In-line Pump



● Bare Shaft End Suction Centrifugal Pump



● End Suction Centrifugal Pump