

Tideway

PNEUMATIC DIAPHRAGM PUMP

(GMB-25 1")



Stainless Steel

Air Consumption (m³/h)

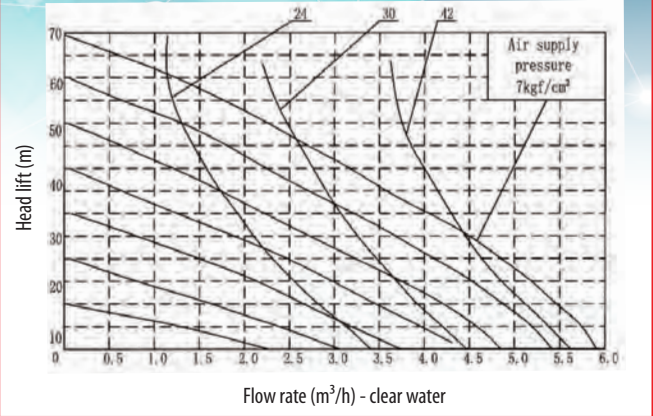

Installation Dimension

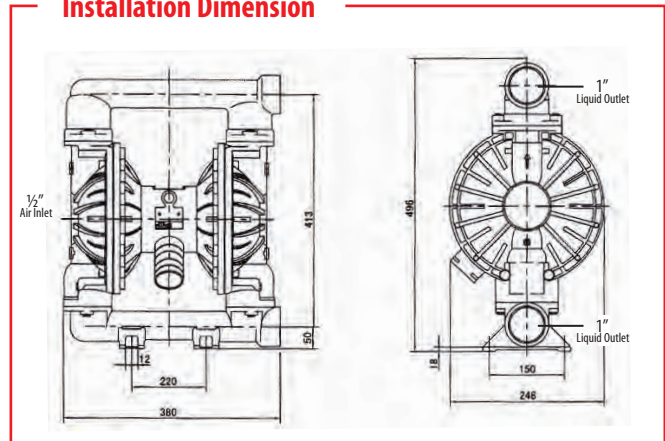

Technical Parameters

Max. Flow Rate	0 - 3.6 m ³ /h		
Max. Lift head	0 - 70 m		
Outlet pressure	0 - 6 kgf/cm ²		
Suction lift	0 - 5 m		
Allowable diameter of grains passing	0 - 2.5 mm		
Air supply pressure	0 - 7 kgf/cm ²		
Air consumption	0 - 600 L/min		
Inlet	1/2 inch		
Outlet	3/4 inch		
Net weight	Polypropylene - 12 kg		
	Aluminum - 20 kg		
	Stainless Steel - 29 kg		
Gross weight	Carton packaging, plus : 1.8 kg		
881218013A - GMB2A-25B	881218017A - GMB2S-25TFF	881218018A - GMB2P-25TFF	881218019A - GMB2A-25TFF

*** Product's specification subject to change without further notice.
 *** Actual product may slightly differ from pictures shown.

ESM411 - GMB25
 (16/12/19)