



VSY SERIES 50 Hz

6" NORYL® SUBMERSIBLE PUMPS



INDEX

6" Noryl®* Submersible pumps	2
Family curves	3
Pump identification code	3
Materials/Fluids compatibility	4
Table of Hydraulic performance at 50 Hz	5
TECHNICAL DATA AND PERFORMANCE CURVES AT 50 Hz	
VSY 10	6
VSY 15	8
VSY 24	10
PUMP SECTION AND LIST OF MAIN COMPONENTS	
	12
APPENDIX A	
Motor adapter and dimensions	13

*Noryl® is a Registered Trademark of G.E.

NOTE: Franklin Electric S.r.l. reserves the right to amend specification without prior notice
For the most up-to-date product information, visit franklinwater.eu.



6" NORYL® * SUBMERSIBLE PUMPS

APPLICATION

- Municipal water works
- Water distribution and pressure boosting
- Irrigation and sprinkler systems, water treatment plants, filtration and reverse osmosis
- Industrial cooling and processing
- Mining industry, drainage and dewatering
- Fire-fighting equipment
- Fountains

FEATURES

- Fabricated Noryl®* impellers and diffusers
- Compact, reliable and suited to operate in horizontal position
- Built-in check valve to protect the pump against water hammer risk
- External stainless steel sleeve to improve stiffness and assure permanent alignment of all the components
- The hydraulic design is such to enhance the overall efficiency thus reducing energy consumption and making the pumping systems more cost effective

PUMP SPECIFICATION

- Flow: up to 32 m³/h at 50 Hz
- Head: up to 346 m at 50 Hz
- Water temperature range: from 0 °C to 40 °C
- Maximum allowable amount of sand 100 g/m³
- Rotation: counter clockwise when looking into the discharge
- Pump can work continuously in vertical or horizontal position

MOTOR SPECIFICATION

- Motor adapter in compliance with NEMA standard
- For more information consult the product catalog of Submersible motors

AVAILABLE ON REQUEST

- Double cable guard
- Rp 3" discharge head for VSY10 and VSY15
- 4" motor adapter

*Noryl® is a Registered Trademark of G.E.

FAMILY CURVES

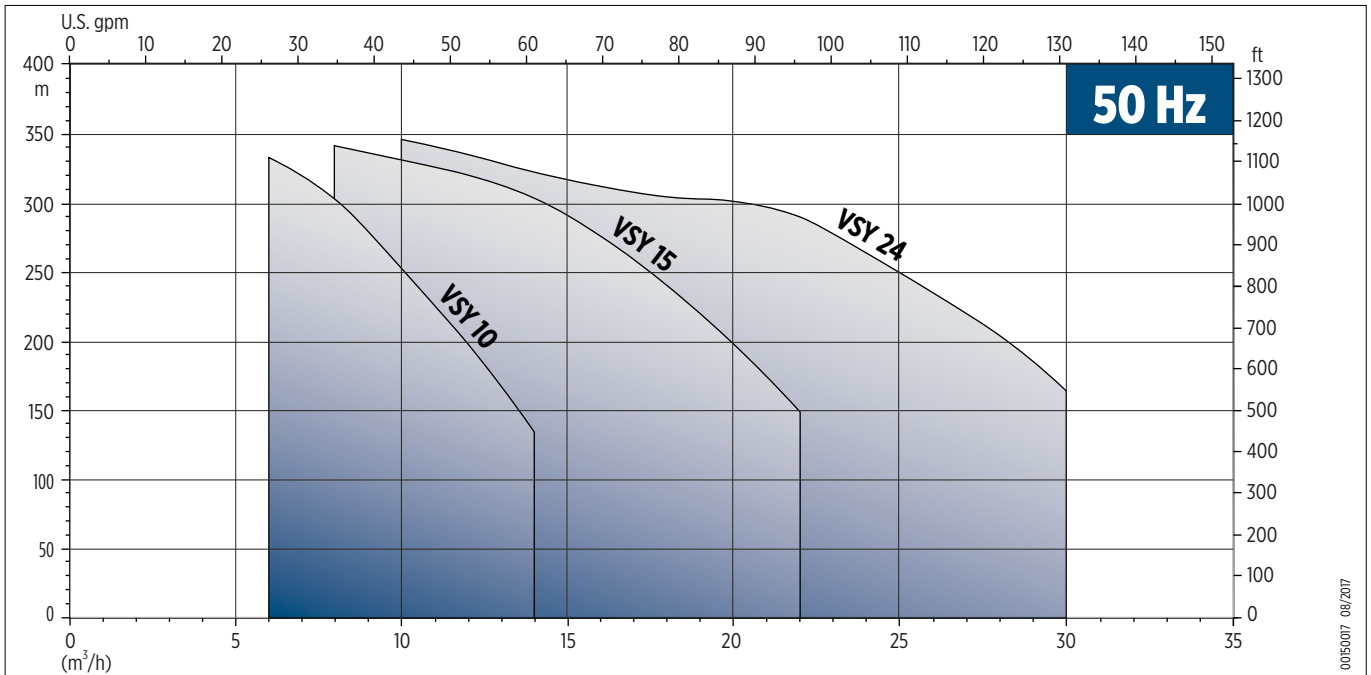

PUMP IDENTIFICATION CODE

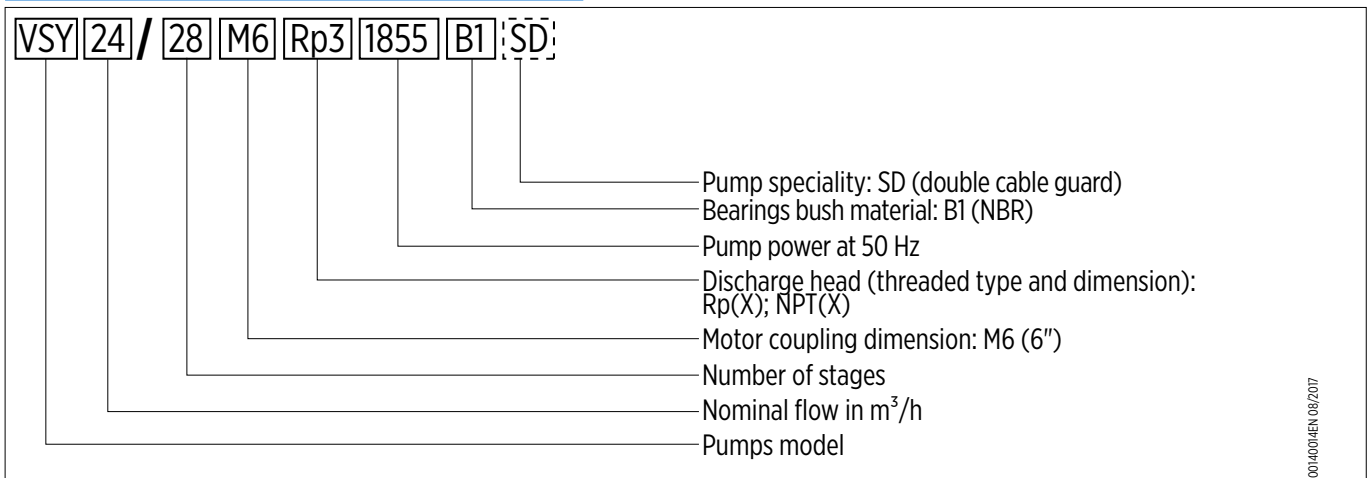



MATERIALS/FLUIDS COMPATIBILITY

Pos.	Part description	Type	Material	
			AISI	DIN / EN
10.00	Discharge head and screw	Stainless Steel	304	1.4301
10.01	Valve	Stainless Steel	316	1.4401
10.02	Kit O-ring (n° 3)	Nitrile rubber (NBR)	-	-
10.03	Screws and outer case locking nuts	Stainless Steel	316	1.4401
10.04	Valve support	Stainless Steel	316	1.4401
10.05	Seeger ring	Stainless Steel	316	1.4401
20.00	Outer case	Stainless Steel	304	1.4301
20.01	Suction strainer	Stainless Steel	316	1.4401
20.02	Cable guard and screws	Stainless Steel	316	1.4401
20.03	Initial spacer	Stainless Steel	304	1.4301
20.04	Flange and bolts	Stainless Steel	304	1.4301
20.05	Motor adapter	Stainless Steel	304	1.4301
20.08	First spacer	Noryl® * + 304 Stainless Steel	-	-
30.00	Pump shaft	Stainless Steel	304	1.4301
30.01	Coupling	Stainless Steel	304	1.4301
30.04	Bushing upper journal sleeve	Stainless Steel	420	1.4021
30.05	Screw and washer	Stainless Steel	304 / 420	1.4301 / 1.4021
30.07	Lower spacer	Noryl® *	-	-
40.05	Bearing housing assembly	Noryl® *	-	-
60.00	Diffuser and impeller assembled	Noryl® *	-	-

*Noryl® is a Registered Trademark of G.E.

VSY 10

TABLE OF HYDRAULIC PERFORMANCE AT 50 HZ

Pump model	RATED POWER		Q = DELIVERY									
			m ³ /h 0	6	7	8	9	10	11	12	13	14
	[kW]	[HP]	l/min 0	100	117	133	150	167	184	200	217	233
H = TOTAL HEAD METERS COLUMN OF WATER [m]												
VSY 10/05	1.5	2	49	42.5	40.5	38.5	35.5	32	28.5	25	21	17
VSY 10/08	2.2	3	77	66.5	63	60	54.5	49.5	44	38	32	26
VSY 10/11	3	4	106.5	92	87.5	83	76	69	61	53.5	45	36
VSY 10/14	4	5.5	137.5	119	114	108	99.5	90	80.5	70.5	60	48.5
VSY 10/18	5.5	7.5	177	154	147	140	129	117	104.5	91.5	78	63
VSY 10/21	5.5	7.5	205	177.5	169.5	160.5	147.5	134	119	104	88	71
VSY 10/25	7.5	10	244.5	212	202.5	192	175.5	160.5	143	125	106	85.5
VSY 10/28	7.5	10	272	235	224.5	212	195	177	157	137	116	93.5
VSY 10/32	9.3	12.5	313.5	272.5	260.5	246.5	227.5	206.5	184	161	137	111
VSY 10/36	9.3	12.5	351	303.5	289.5	274	252	228.5	203	177.5	150	121
VSY 10/39	11	15	381	329.5	314.5	297.5	273.5	248.5	221	193	163.5	132

VSY 15

TABLE OF HYDRAULIC PERFORMANCE AT 50 HZ

Pump model	RATED POWER		Q = DELIVERY										
			m ³ /h 0	8	10	12	13	14	15	16	18	20	22
	[kW]	[HP]	l/min 0	133	167	200	217	233	250	266	300	334	367
H = TOTAL HEAD METERS COLUMN OF WATER [m]													
VSY 15/06	3	4	59	53.5	52	50	48.5	47	45	43	37.5	30.5	23
VSY 15/08	4	5.5	80	72	70	67.5	66	64	61.5	58.5	51	42	32
VSY 15/12	5.5	7.5	119	108	104.5	100.5	98.5	95.5	91.5	87	76	62	47
VSY 15/15	7.5	10	148.5	134	130.5	126	123	119	114.5	108.5	94.5	78	58.5
VSY 15/18	9.3	12.5	179.5	162.5	158	152.5	149	144.5	139	132	115.5	95.5	72
VSY 15/23	11	15	227.5	205.5	199.5	192	187.5	181.5	174.5	165.5	144	118	88.5
VSY 15/26	15	20	260	236	229.5	222	217	210.5	202.5	193	169	140	106.5
VSY 15/30	15	20	298.5	269.5	262	253	247	239.5	230	219	191	157	118.5
VSY 15/34	18.5	25	340	308	299.5	289.5	282.5	274.5	264	251.5	220	182	138
VSY 15/38	18.5	25	377.5	341.5	332	320.5	313	303.5	291.5	277	242	199	150

VSY 24

TABLE OF HYDRAULIC PERFORMANCE AT 50 HZ

Pump model	RATED POWER		Q = DELIVERY											
			m ³ /h 0	10	12	14	16	18	20	22	24	26	28	30
	[kW]	[HP]	l/min 0	167	200	233	266	300	334	267	400	433	466	500
H = TOTAL HEAD METERS COLUMN OF WATER [m]														
VSY 24/04	3	4	38	34	33	32	30.5	30	29.5	28.5	25.5	23	19.5	16
VSY 24/06	4	5.5	57.5	51.5	50	48	46.5	45	44.5	43	39	35	30	24
VSY 24/08	5.5	7.5	76.5	69	66.5	64	62	60.5	60	57.5	52	46.5	40	32
VSY 24/12	7.5	10	113.5	101.5	98.5	94.5	91.5	89	88	84	76	67.5	57.5	46
VSY 24/14	9.3	12.5	133.5	120	116	111.5	108	105	104	99.5	90.5	80.5	69.5	55.5
VSY 24/18	11	15	170.5	152.5	147	141.5	137	133.5	131.5	125.5	113.5	100.5	86	68.5
VSY 24/20	15	20	191.5	172.5	167	160.5	155.5	152	150	144	131	117	101	81.5
VSY 24/23	15	20	219	196.5	190	183	176.5	172.5	170.5	163	147.5	131.5	113	90.5
VSY 24/28	18.5	25	267	240	232	223.5	215.5	210.5	208	199	180.5	161.5	138.5	111.5
VSY 24/34	22	30	323.5	290.5	281	270.5	261.5	255	252	241	218.5	194.5	167.5	134
VSY 24/40	30	40	383.5	346	335	323	312	305	301.5	290	264	235.5	204.5	165.5

VSY 10 50 Hz

TECHNICAL DATA - PUMPS WITH ENCAPSULATED MOTOR

Pump model	Motor			Dimensions					Weight [Kg]		
	Type	[kW]	[HP]	L1 [mm]	L2 [mm]	Lt [mm]	D		Pump	Motor	Total
							1 cable	2 cable			
VSY 10/05	E4	1.5	2	485	306	791	142.5	-	10	11.2	21.2
VSY 10/08	E4	2.2	3	589	422	1011	142.5	-	11.5	15	26.5
VSY 10/11	E4	3	4	694	477	1171	142.5	-	13	17	30
VSY 10/14	E4	3.7	5	798	520	1318	142.5	-	14.5	19.6	34.1
VSY 10/18	E4	5.5	7.5	938	652	1590	142.5	-	16.5	28.7	45.2
VSY 10/21	E4	5.5	7.5	1042	652	1694	142.5	-	18.5	28.7	47.2
VSY 10/25	E4	7.5	10	1182	730	1912	142.5	-	20	32.7	52.7
VSY 10/28	E4	7.5	10	1286	730	2016	142.5	-	22	32.7	54.7
VSY 10/05	E6	4	5.5	485	581	1066	143	144.5	10	37.5	47.5
VSY 10/08	E6	4	5.5	589	581	1170	143	144.5	11.5	37.5	49
VSY 10/11	E6	4	5.5	694	581	1275	143	144.5	13	37.5	50.5
VSY 10/14	E6	4	5.5	798	581	1379	143	144.5	14.5	37.5	52
VSY 10/18	E6	5.5	7.5	938	614.5	1553	143	144.5	16.5	41.1	57.6
VSY 10/21	E6	5.5	7.5	1042	614.5	1657	143	144.5	18.5	41.1	59.6
VSY 10/25	E6	7.5	10	1182	646	1828	143	144.5	20	45.2	65.2
VSY 10/28	E6	7.5	10	1286	646	1932	143	144.5	22	45.2	66.7
VSY 10/32	E6	9.3	12.5	1488	678.5	2167	143	144.5	24	47.5	71.5
VSY 10/36	E6	9.3	12.5	1628	678.5	2307	143	144.5	26	47.5	73.5
VSY 10/39	E6	11	15	1732	711	2443	143	144.5	27.5	50.9	78.4

TECHNICAL DATA - PUMPS WITH REWINDABLE MOTOR

Pump model	Motor			Dimensions					Weight [Kg]		
	Type	[kW]	[HP]	L1 [mm]	L2 [mm]	Lt [mm]	D		Pump	Motor	Total
							1 cable	2 cable			
VSY 10/05	RW6	4	5.5	485	699	1184	147	147.5	10	43	53
VSY 10/08	RW6	4	5.5	589	699	1288	147	147.5	11.5	43	54.5
VSY 10/11	RW6	4	5.5	694	699	1393	147	147.5	13	43	56
VSY 10/14	RW6	4	5.5	798	699	1497	147	147.5	14.5	43	57.5
VSY 10/18	RW6	5.5	7.5	938	699	1637	147	147.5	16.5	43	59.5
VSY 10/21	RW6	5.5	7.5	1042	700	1742	147	147.5	18.5	44	62.5
VSY 10/25	RW6	7.5	10	1182	719	1901	147	147.5	20	45	65
VSY 10/28	RW6	7.5	10	1286	719	2005	147	147.5	22	45	66.5
VSY 10/32	RW6	9.3	12.5	1488	749	2237	147	147.5	24	48	72
VSY 10/36	RW6	9.3	12.5	1628	749	2377	147	147.5	26	48	74
VSY 10/39	RW6	11	15	1732	779	2511	147	147.5	27.5	51	78.5

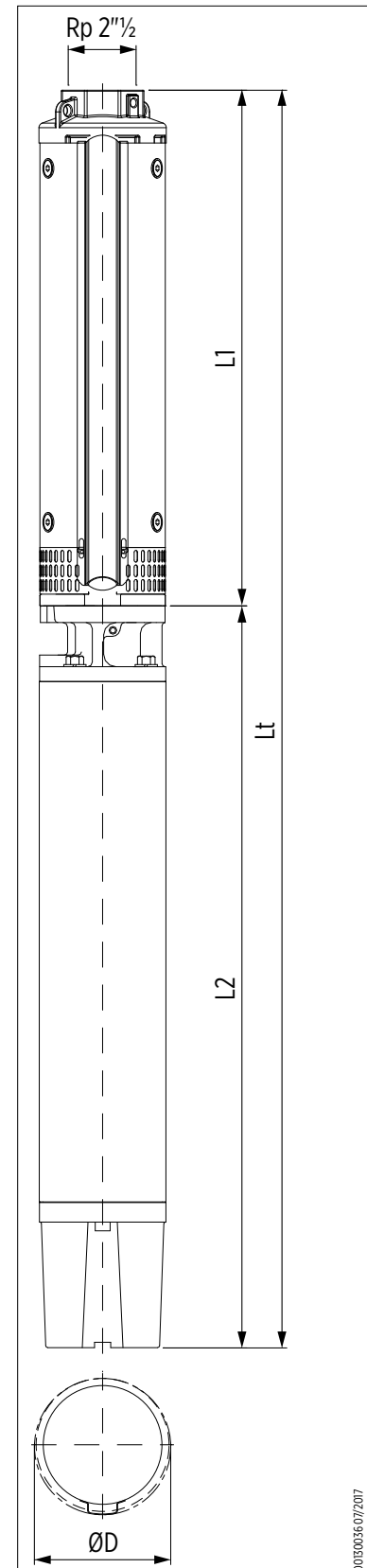

PERFORMANCE CURVES AT 50 Hz

MEI ≥ 0,40

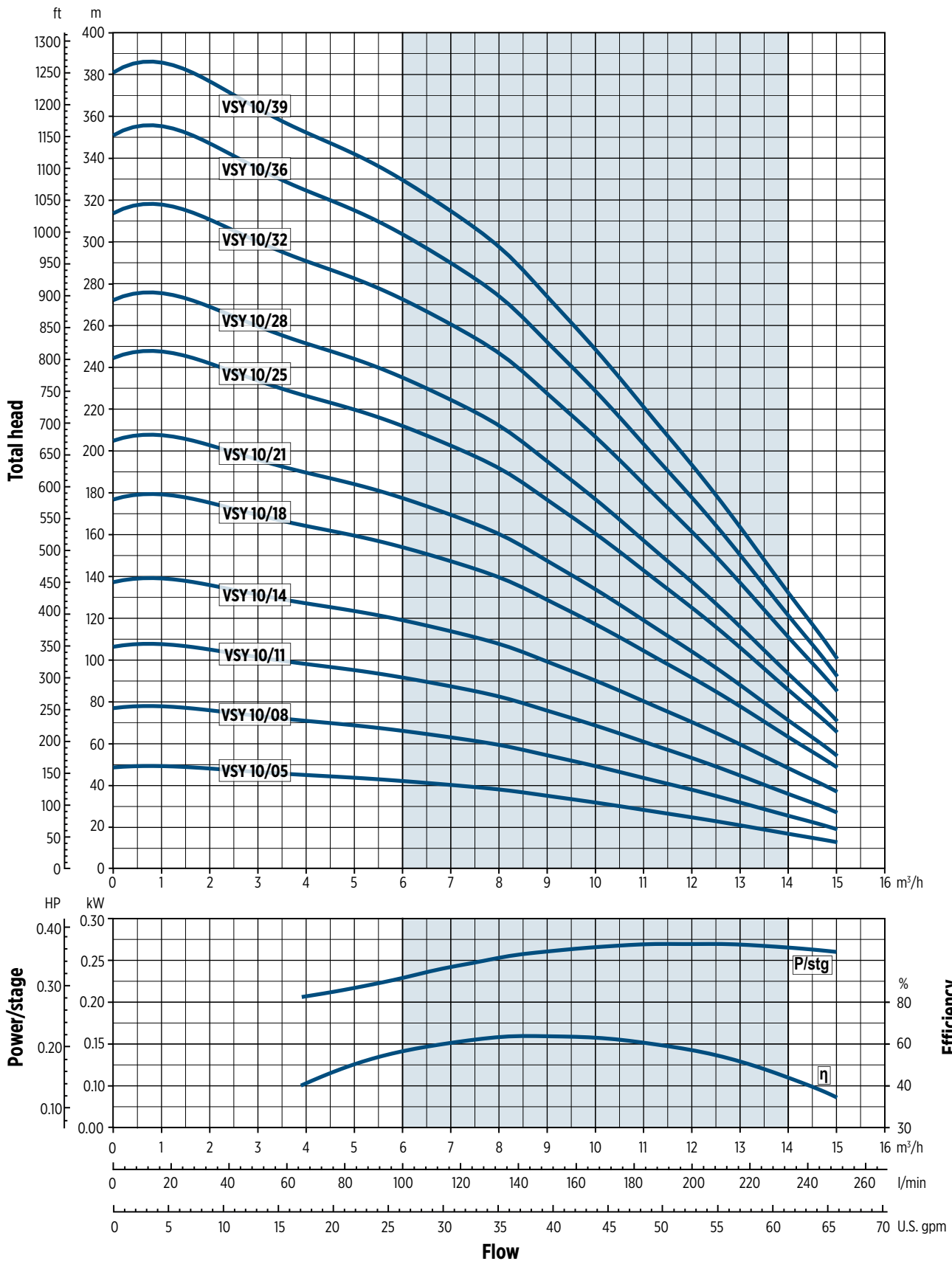

00120084EN/08/2017

VSY 15 50 Hz

TECHNICAL DATA - PUMPS WITH ENCAPSULATED MOTOR

Pump model	Motor			Dimensions					Weight [Kg]		
	Type	[kW]	[HP]	L1 [mm]	L2 [mm]	Lt [mm]	D		Pump	Motor	Total
							1 cable	2 cable			
VSY 15/06	E4	3	4	550	477	1027	142.5	-	10.5	17	27.5
VSY 15/08	E4	3.7	5	630	520	1150	142.5	-	12	19.6	31.6
VSY 15/12	E4	5.5	7.5	790	652	1442	142.5	-	14	28.7	42.7
VSY 15/15	E4	7.5	10	910	730	1640	142.5	-	15.5	32.7	48.2
VSY 15/06	E6	4	5.5	550	581	1131	143	144.5	10.5	37.5	48
VSY 15/08	E6	4	5.5	630	581	1211	143	144.5	12	37.5	49.5
VSY 15/12	E6	5.5	7.5	790	614.5	1405	143	144.5	14	41.1	55.1
VSY 15/15	E6	7.5	10	910	646	1556	143	144.5	15.5	45.2	60.7
VSY 15/18	E6	9.3	12.5	1030	678.5	1709	143	144.5	17	47.5	64.5
VSY 15/23	E6	11	15	1292	711	2003	143	144.5	20	50.9	70.9
VSY 15/26	E6	15	20	1412	776	2188	143	144.5	21.5	56.7	78.2
VSY 15/30	E6	15	20	1572	776	2348	143	144.5	23.5	56.7	80.2
VSY 15/34	E6	18.5	25	1731	841.5	2573	143	144.5	25.5	63.3	88.8
VSY 15/38	E6	18.5	25	1891	841.5	2733	143	144.5	28	63.3	91.3

TECHNICAL DATA - PUMPS WITH REWINDABLE MOTOR

Pump model	Motor			Dimensions					Weight [Kg]		
	Type	[kW]	[HP]	L1 [mm]	L2 [mm]	Lt [mm]	D		Pump	Motor	Total
							1 cable	2 cable			
VSY 15/06	RW6	4	5.5	550	699	1249	147	147.5	10.5	43	53.5
VSY 15/08	RW6	4	5.5	630	699	1329	147	147.5	12	43	55
VSY 15/12	RW6	5.5	7.5	790	699	1489	147	147.5	14	43	57
VSY 15/15	RW6	7.5	10	910	719	1629	147	147.5	15.5	45	60.5
VSY 15/18	RW6	9.3	12.5	1030	749	1779	147	147.5	17	48	65
VSY 15/23	RW6	11	15	1292	779	2071	147	147.5	20	51	71.5
VSY 15/26	RW6	13	17.5	1412	829	2241	147	147.5	21.5	56	78
VSY 15/30	RW6	15	20	1572	874	2446	147	147.5	23.5	61	85
VSY 15/34	RW6	18.5	25	1731	919	2650	147	147.5	25.5	65	91
VSY 15/38	RW6	18.5	25	1891	919	2810	147	147.5	28	65	93.5

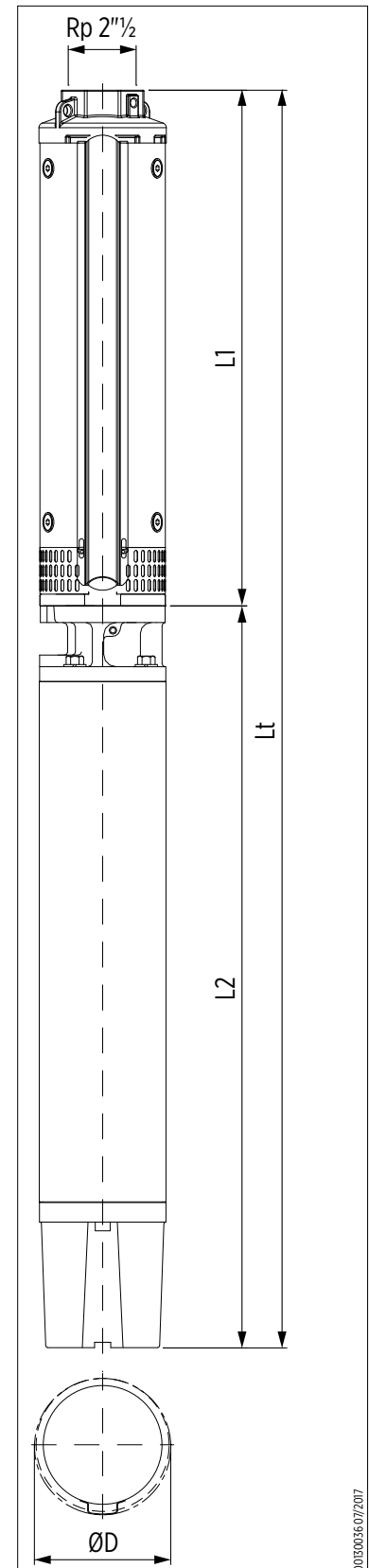

PERFORMANCE CURVES AT 50 Hz

MEI ≥ 0,40

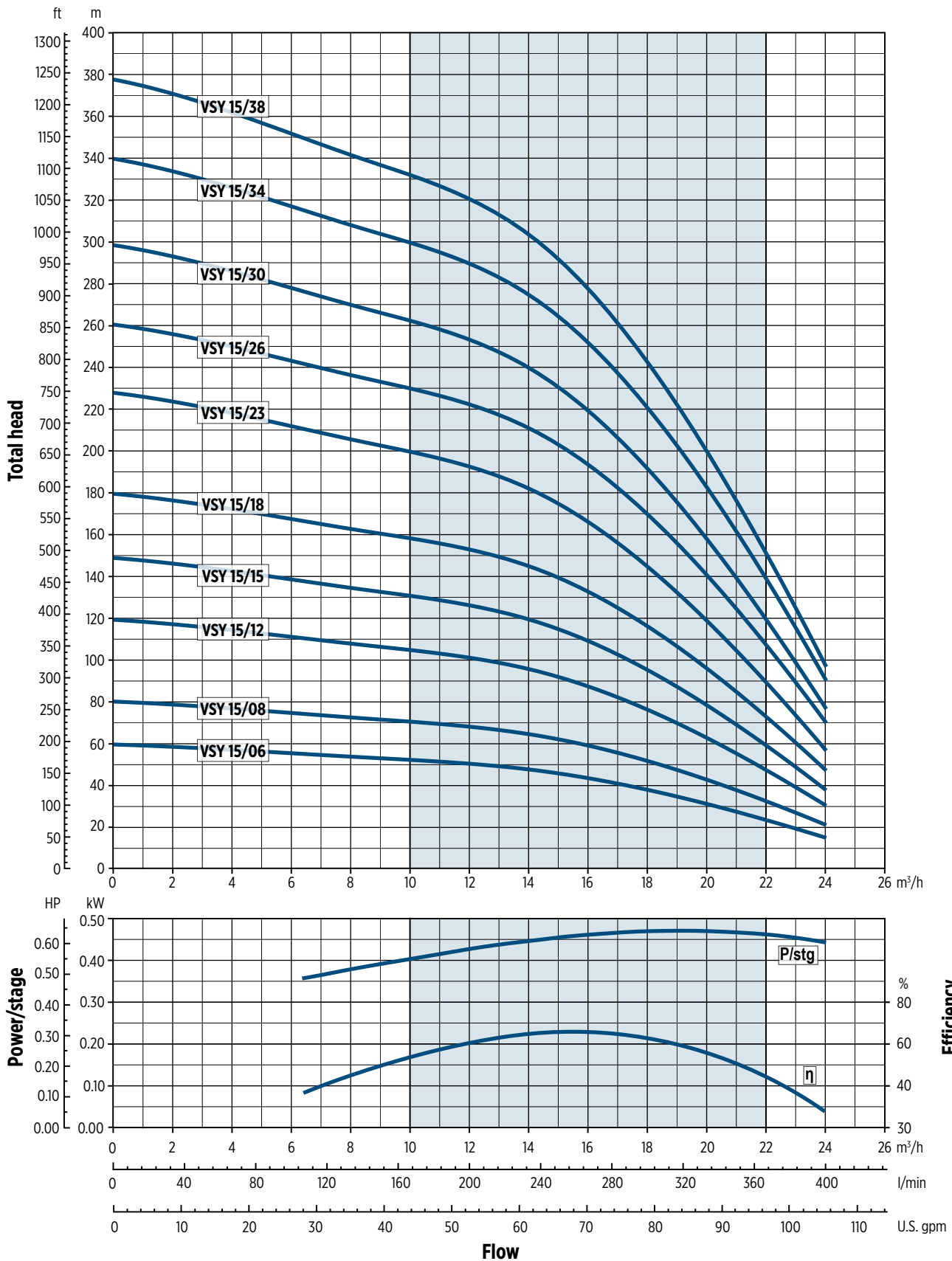

0072005EN/08/2017

VSY 24 50 Hz

TECHNICAL DATA - PUMPS WITH ENCAPSULATED MOTOR

Pump model	Motor			Dimensions					Weight [Kg]		
	Type	[kW]	[HP]	L1 [mm]	L2 [mm]	Lt [mm]	D		Pump	Motor	Total
							1 cable	2 cable			
VSY 24/04	E4	3	4	551	477	1028	142.5	-	11	17	28
VSY 24/06	E4	3.7	5	651	520	1171	142.5	-	12	19.6	31.6
VSY 24/08	E4	5.5	7.5	751	652	1403	142.5	-	13.5	28.7	42.2
VSY 24/12	E4	7.5	10	950	730	1680	142.5	-	16	32.7	48.7
VSY 24/04	E6	4	5.5	551	581	1132	143	144.5	11	37.5	48.5
VSY 24/06	E6	4	5.5	651	581	1232	143	144.5	12	37.5	49.5
VSY 24/08	E6	5.5	7.5	751	614.5	1366	143	144.5	13.5	41.1	54.6
VSY 24/12	E6	7.5	10	950	646	1596	143	144.5	16	45.2	61.2
VSY 24/14	E6	9.3	12.5	1050	678.5	1729	143	144.5	17.5	47.5	65
VSY 24/18	E6	11	15	1249	711	1960	143	144.5	20	50.9	70.9
VSY 24/20	E6	15	20	1412	776	2188	143	144.5	22	56.7	78.7
VSY 24/23	E6	15	20	1562	776	2338	143	144.5	23.5	56.7	80.2
VSY 24/28	E6	18.5	25	1811	841.5	2653	143	144.5	27.5	63.3	90.8
VSY 24/34	E6	22	30	2110	906.5	3017	143	144.5	31.5	69.3	100.8
VSY 24/40	E6	30	40	2472	1036.5	3509	143	144.5	35.5	83.9	119.4

TECHNICAL DATA - PUMPS WITH REWINDABLE MOTOR

Pump model	Motor			Dimensions					Weight [Kg]		
	Type	[kW]	[HP]	L1 [mm]	L2 [mm]	Lt [mm]	D		Pump	Motor	Total
							1 cable	2 cable			
VSY 24/04	RW6	4	5.5	551	699	1250	147	147.5	11	43	54
VSY 24/06	RW6	4	5.5	651	699	1350	147	147.5	12	43	55
VSY 24/08	RW6	5.5	7.5	751	699	1450	147	147.5	13.5	43	56.5
VSY 24/12	RW6	7.5	10	950	719	1669	147	147.5	16	45	61
VSY 24/14	RW6	9.3	12.5	1050	749	1799	147	147.5	17.5	48	65.5
VSY 24/18	RW6	11	15	1249	779	2028	147	147.5	20	51	71
VSY 24/20	RW6	13	17.5	1412	829	2241	147	147.5	22	56	78
VSY 24/23	RW6	15	20	1562	874	2436	147	147.5	23.5	61	84.5
VSY 24/28	RW6	18.5	25	1811	919	2730	147	147.5	27.5	65	92.5
VSY 24/34	RW6	22	30	2110	1009	3119	147	147.5	31.5	74	105.5
VSY 24/40	RW6	26	35	2472	1114	3586	147	147.5	35.5	85	120.5

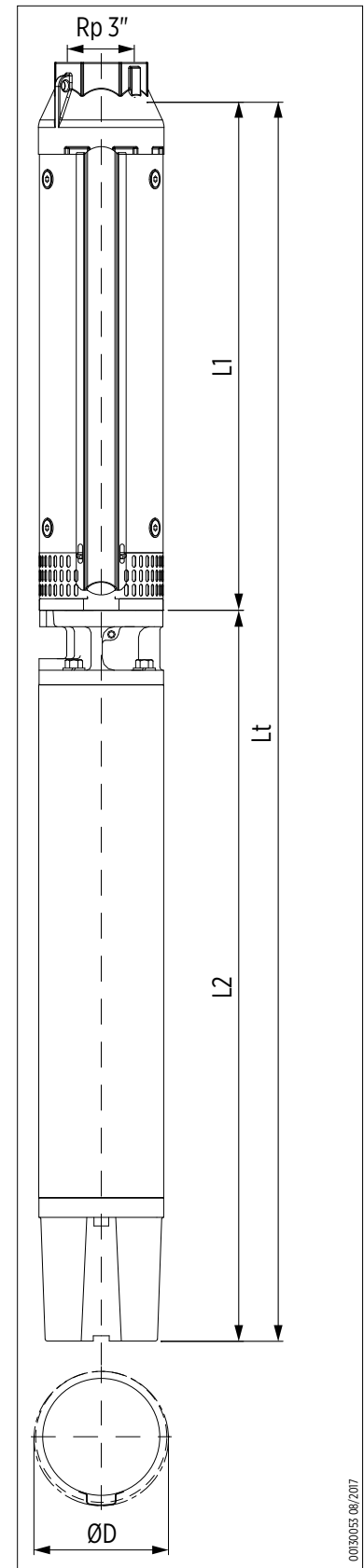

0030055 08/2017

PERFORMANCE CURVES AT 50 Hz

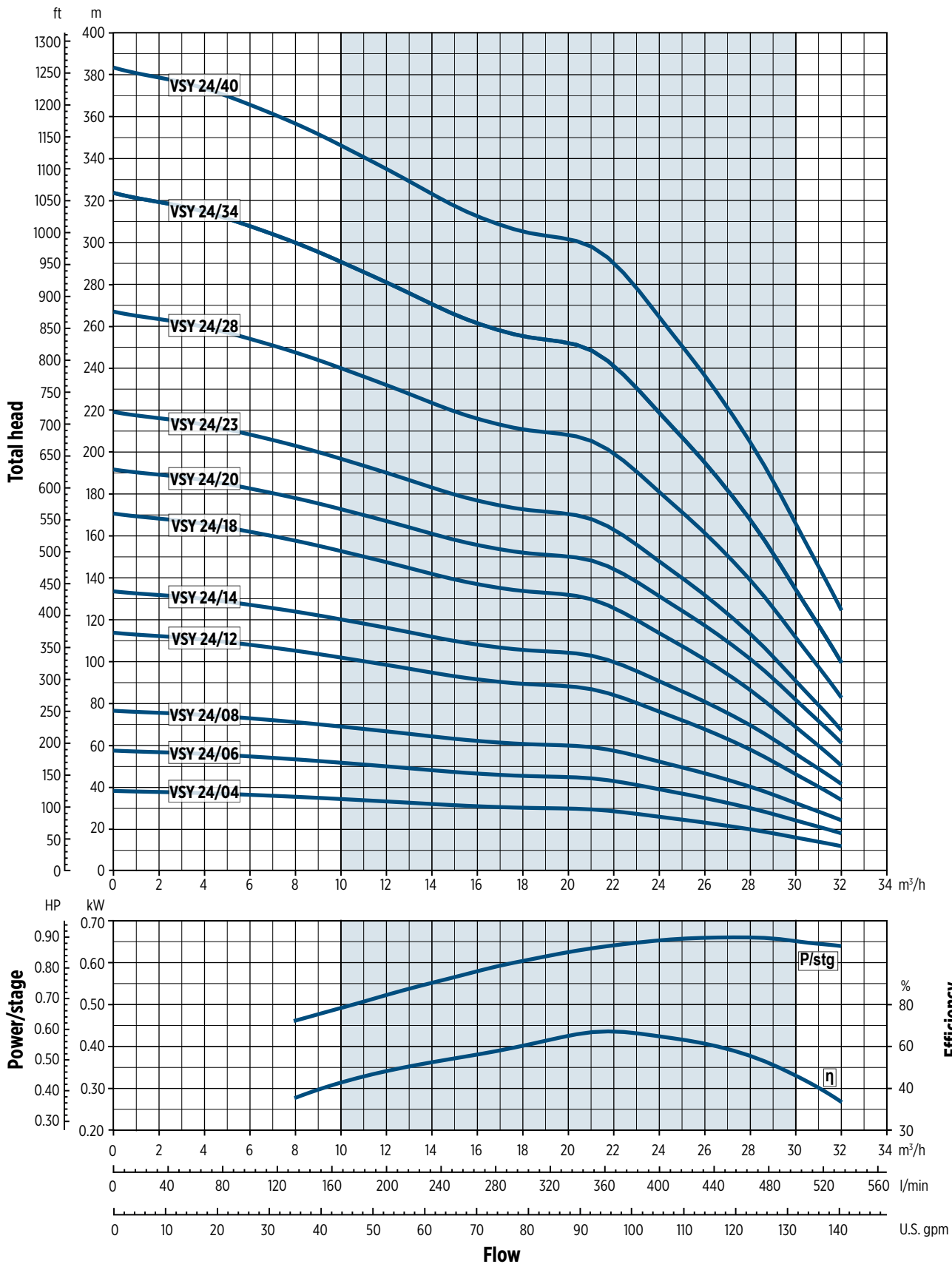

The hydraulic characteristics are guaranteed, according to ISO standard 9906:2012, grade 3B

VSY 10-15-24

PUMP SECTION AND LIST OF MAIN COMPONENTS

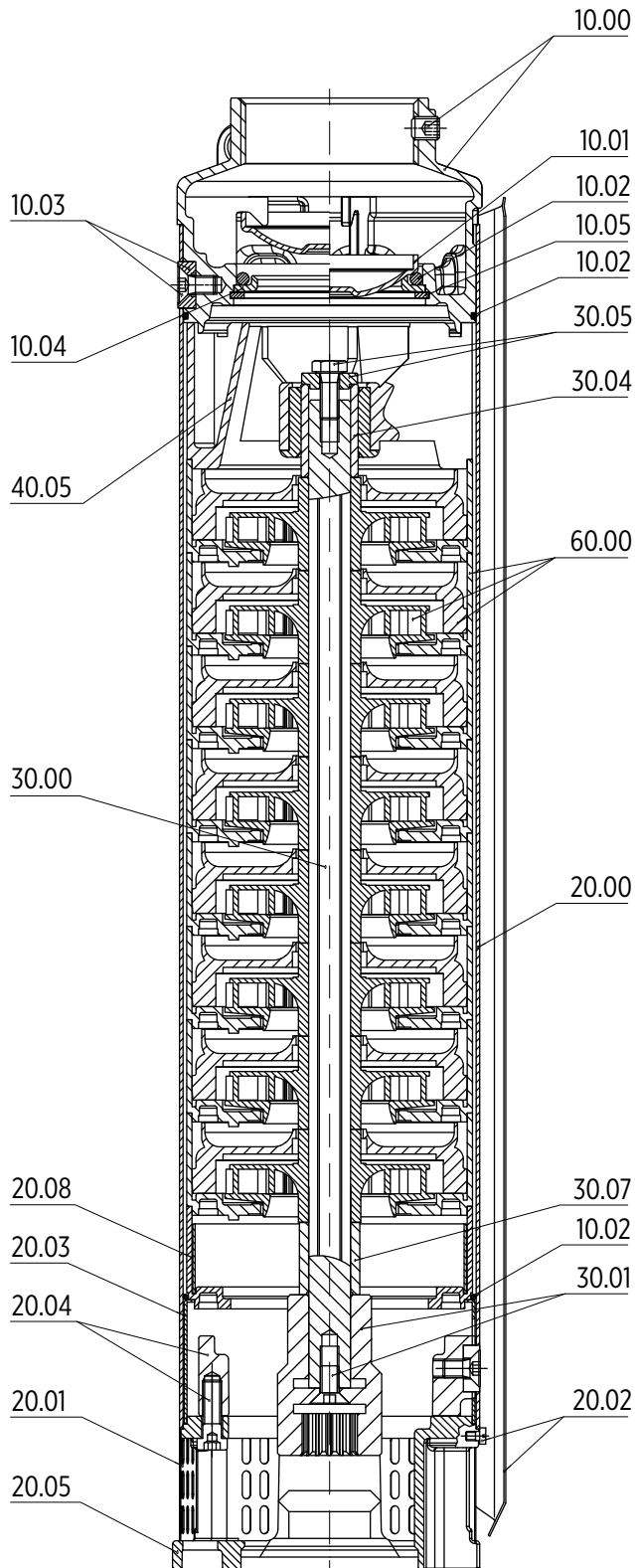

Pos.	Description	Material
10.00	Discharge head and screw	304 SS
10.01	Valve	316 SS
10.02	Kit O-ring	NBR
10.03	Screws and outer case locking nuts	316 SS
10.04	Valve support	316 SS
10.05	Seeger ring	316 SS
20.00	Outer case	304 SS
20.01	Suction strainer	316 SS
20.02	Cable guard and screws	316 SS
20.03	Initial spacer	304 SS
20.04	Flange and bolts	304 SS
20.05	Motor adapter	304 SS
20.06	4" motor flange/coupling adapter	316 SS
20.08	First spacer	Noryl® * + 304 SS
30.00	Pump shaft	304 SS
30.01	Coupling	304 SS
30.04	Bushing upper journal sleeve	420 SS
30.05	Screw and washer	304 SS / 420 SS
30.07	Lower spacer	Noryl® *
40.05	Bearing housing assembly	Noryl® *
60.00	Diffuser and impeller assembled	Noryl® *

* Noryl® is a Registered Trademark of G.E.

MOTOR ADAPTER 6x4

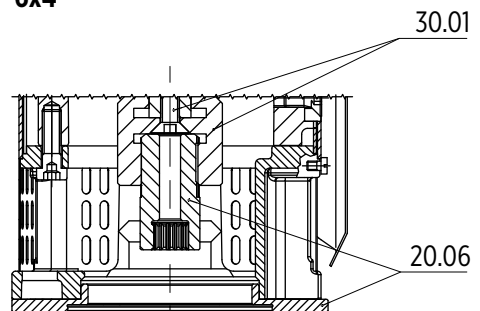

00130059EN 08/2017

00130059EN 08/2017

MOTOR ADAPTER AND DIMENSIONS

APPENDIX A

4" MOTOR ADAPTER

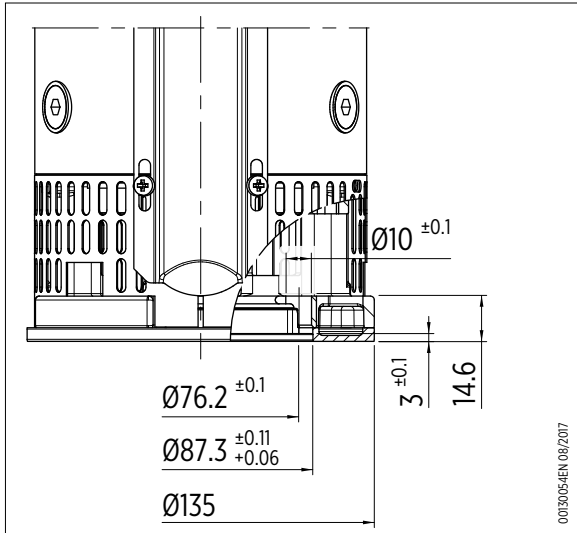

6" MOTOR ADAPTER

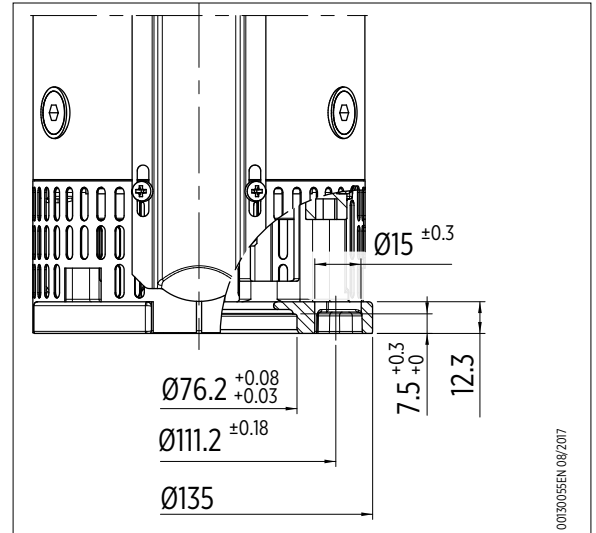



Franklin Electric

Franklin Electric S.r.l.
Via Asolo, 7 - 36031 Dueville (Vicenza) - ITALY
Phone: +39 0444 361114 - Fax: +39 0444 365247
Email: sales.it@fele.com

Single member - Company subject to the control and coordination of Franklin Electric Co., Inc.

Franklin Electric S.r.l. reserves the right to amend specification without prior notice

00104240EN_REV.02_11/2017

franklinwater.eu