

Hydro EN

Pumping sets according to
UNI EN 12845, UNI 10779 and UNI 11292 Standards
with end-suction type electric and/or diesel driven pumps

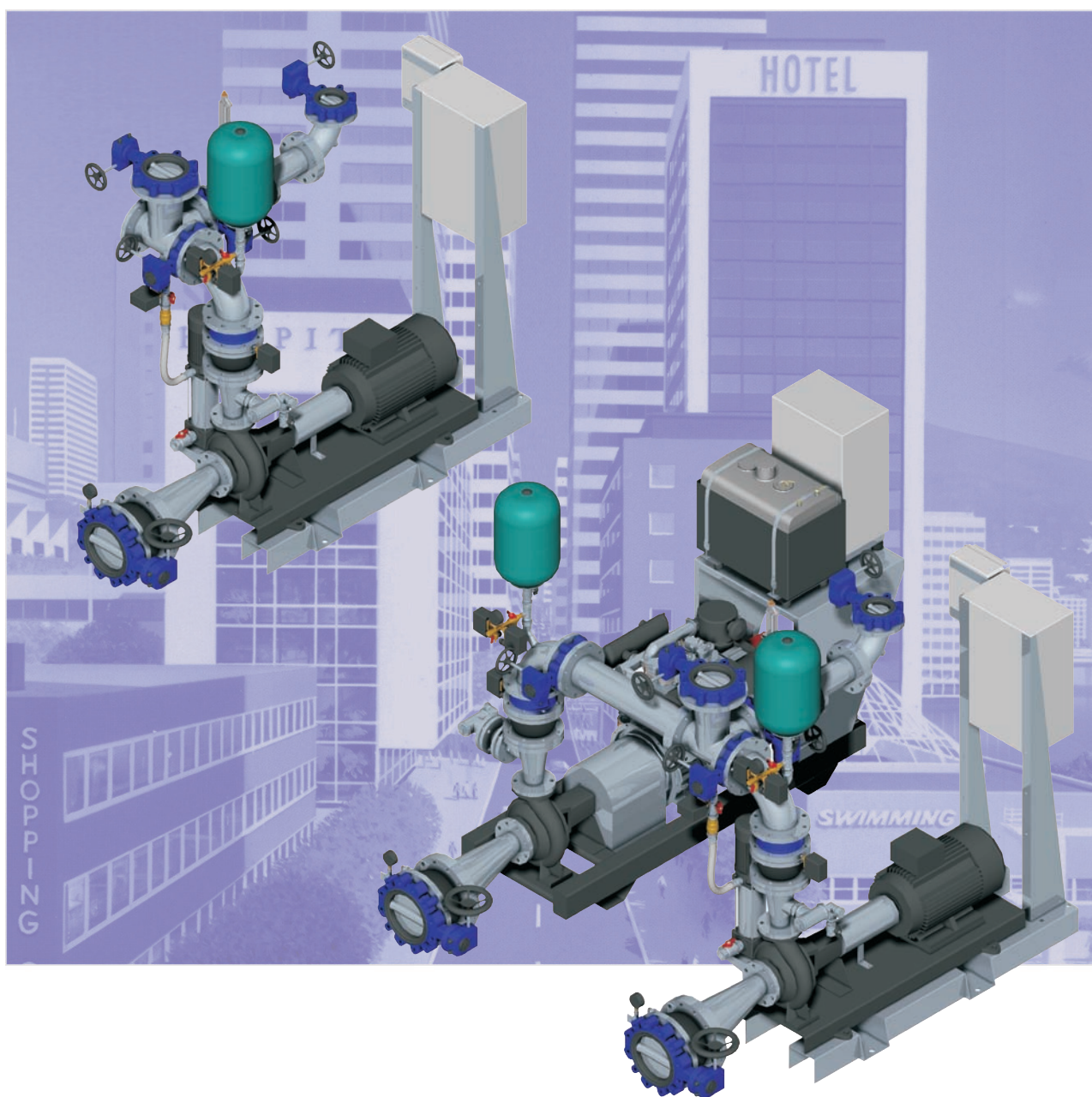

➤ Description

The **Grundfos Hydro EN** automatic pumping sets for fire-protection are built in compliance with the requirements from the designated Standards (see Normative references), **whose indication is provided for the relevant point** (normally referred to the EN 12845, if not otherwise specified).

The Hydro EN pumping sets are designed for fire extinguishing systems with water supplies of the single (9.6.1), single superior (9.6.2) and double (9.6.3) types.

In sets with two pumps, each one must be capable of delivering the required design performance (10.2). In sets with three pumps, each one must be capable of delivering 50% of the capacity at the required design head (10.2).

In case of single superior or double types of water supplies, no more than one pump can be driven by an electric motor (10.2).

When present, the second or third pumps are stand-by units to secure the water supply to the fire-fighting system in case the first pump is inefficient.

In case of sets with two or three pumps, the performances are compatible to work in parallel (10.2) and they are connected with a common discharge piping plus hydraulic and control components, whereas suction is independent.

The Hydro EN pumping sets are supplied as:

- **Hydro EN-S**, with 1 or 2 end-suction main pumps having the same hydraulic performance, operated by an electric motor (electric pumps),
- **Hydro EN-Y**, with 2 end-suction duty pumps having the same hydraulic performance, one operated by an electric motor (electric pump) and the other by a diesel engine (diesel pump),
- **Hydro EN-T**, with 1 or 2 end-suction duty pumps having the same hydraulic performance, operated by a diesel engine (diesel pumps).

The execution is completed by:

- a **Grundfos CMV** or **CR** series vertical multi-stage jockey pump for pressure maintenance (10.6.2.5) which automatically guarantees system pressurization in case of leaks so as to prevent unjustified start-up of the main pumps,
- 1 or 2 diaphragm pressure tanks with 24l capacity, PN16, for correct operation of the jockey pump; an independent control panel for each main pump and one for the jockey pump,
- an independent control panel for each main pump and one for the jockey pump,
- two pressure switches for each main pump hydraulically connected by a single-piece device with built-in complementary components (10.7.5.1; Figure 6 ref. 10),
- DN 50 arrangements for all the pumps for the connection of the priming tank, if any (10.6.2.4)
- by-pass output for the recirculation of partial flow to prevent overheating of the pump in case of operation against closed valve (10.5),
- flow rate test loop with throttling valve for reading of the design performance values (8.5; 8.5.1.b),
- a silencer of the industrial type for the diesel pumps.

The lay-out of the parts allows an easy reading of the measurement instruments and signals, also during the

periodic test routine (20.3.4.2).

The main pumps are subjected to automatic start and manual stop (10.7.5.2). The automatic stop function, for hose reel and hydrants systems only (UNI 10779, A.1.2) is supplied on request. The suction manifold can be supplied as optional.

➤ Executions on demand

Changes from what is described in the catalogues or adaptation to specific applications or integration of optional components and/or accessories not included in our standard scope of supply, can be defined in the order. The same applies to the design criteria required by the prescriber of the fire fighting system.

➤ Performance range

Grundfos Hydro Fire pumping sets cover for each duty pump the performance range indicated in the chart below.

Furthermore, units with performance exceeding the following range can be supplied on request.

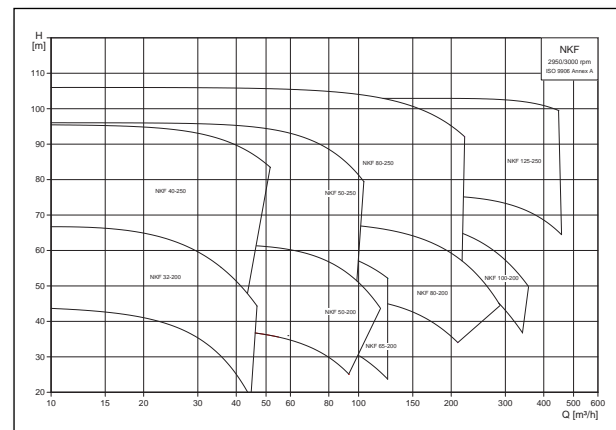

➤ Operating condition

- Flow: up to 450 m³/h per pump.
- Head: 10 bar delivered by the main pumps.
- Performance: according to ISO 9906 Annex A.
- Nominal pressure: PN16 for components and materials.
- Water temperature: from 0°C to +50°C.
- Ambient temperature: from +4°C to +40°C. (min. +10° for diesel pump).

➤ Accessories

Grundfos provides the following optional accessories conceived by the Standards:

- automatic stop function, for hose reel and hydrants systems only (UNI 10779, A.1.2),
- priming tank with the prescribed equipment (10.6.2.4),
- set of spare parts for the diesel engine (10.9.12),
- kit of switches to monitor the state of the main gate valves (D.3.4; H.2.2; UNI 10779, 7.4.3),
- remote signalling alarm units unit with siren and lights of the conforming colours (10.8.6.3), even with SMS alarm sending,
- emergency power supply unit for drainage pump in the installation room (UNI 11292, 6.3.2).

➤ Normative References

Hydro EN automatic pumping sets for water supply of fire systems, are built in compliance with the requirements from the following reference Standards.

■ UNI EN 12845

Automatic sprinkler systems

UNI 10779

■ Hose reel and hydrants systems, related to:

- Gear-operated valves for sizes larger than DN 100,
- possibility of automatic stop of the main pumps.

UNI 11292

■ Compartments for installations of fire fighting pumping sets, for:

- diesel pump fuel tank which prevents dispersion in the case fuel leakage should occur,
- diesel pump fuel tank with connection for the venting pipe,
- hand pump for refilling the fuel tank when the supply point is at a height above 1.5 meters or exceeding 50 lt. of capacity (UNI 11292, 7.3),
- aspects compatible with the instructions for installation.

➤ <CE> mark

The marking <CE> of the Hydro EN Series states the compliance with the provisions of the following directives:

- Machinery (new release EC 2006/42 which prescribes the essential safety requirements,
- Electromagnetic compatibility (2004/108/EC),
- Electrical equipment designed for use within certain voltage limits (2006/95/EC).

BE>THINK>INNOVATE **GRUNDFOS**

Declaration of Conformity
We Grundfos declare under our sole responsibility that the products Hydro EN to which this declaration relates, are in conformity with the Council Directives on the approximation of the laws of the EC Member States relating to:

- Machinery (2006/42/EC)
Standard used: EN 809:1998, EN 60204-1:2006 (except paragraph 7.3)
- Electromagnetic compatibility (2004/108/EC)
Standard used: EN 61000-6-1, EN 61000-6-2, EN 61000-6-3 and EN 61000-6-4:2005
- Electrical equipment designed for use within certain voltage limits (2006/95/EC)
Standard used: EN 60334-1, EN 60334-2, EN 61800-2, EN 60335-1:2002, EN 60335-2-11:2003 e EN 60439-1:2003

Dichiarazione di Conformità
Noi Grundfos dichiariamo sotto la nostra esclusiva responsabilità che i prodotti Hydro EN ai quali questa dichiarazione si riferisce, sono conformi alle direttive del Consiglio, concernenti il avvicinamento delle legislazioni degli Stati membri CE relativi a:

- Macchine (2006/42/CE)
Standard usato: EN 809:1998; EN 60204-1:2006 (escluso paragrafo 7.3)
- Compatibilità elettromagnetica (2004/108/CE)
Standard usati: EN 61 000-6-1, EN 61 000-6-2, EN 61 000-6-3 e EN 61 000-6-4:2005
- Materiale elettrico destinato ad essere utilizzato entro certi limiti di tensione (2006/95/CE)
Standard usati: EN 60334-1, EN 60334-2, EN 61800-2, EN 60335-1:2002, EN 60335-2-11:2003 e EN 60439-1:2003

Truccazzano, 23 Dicembre, 2009

Angelo Colombo
General Manager

Do not remove protective elements during operation.
Divieto di rimozione delle protezioni con organi in moto.

Do not attempt to clean, oil, grease, adjust or repair any parts while in motion.
Divieto di pulire, oliare, ingrassare, regolare o riparare organi in moto.

To move the product use forklift whenever possible.
Per la movimentazione usare preferibilmente il muletto.

Check in the instruction booklet the weight of parts to be moved. Hook lifting equipment directly onto electric pump baseplate or diesel pump skid.
Verificare sul manuale il peso delle parti da movimentare. Agganciare sul telaio di baseplate o diesel pump skid.

Before installing, keep fingers away from moving parts of end valves.
Prima di avere effettuato l'installazione non manovrare le valvole di connessione all'impianto se le estremità sono insorte nel passaggio delle stesse.

Do not touch the diesel engine and its connected items while in operation. Even after stop, wait for all parts to cool down before intervening.
Non toccare il motore Diesel o i suoi componenti durante il funzionamento e dopo la sua fermata, finché la temperatura si sia adeguatamente abbassata.

Be aware of the high water temperature coming from the heat exchanger (if present) of the diesel engine.
Attenzione alla temperatura dell'acqua in uscita dallo scambiatore di calore (se presente) del motore diesel.

Ensure exhaust fumes are correctly piped out of the installation room with no leakage to it.
Accertarsi che il condotto dei fumi del motore diesel scarchi liberamente all'esterno e non abbia fuoriuscite nel locale di installazione.

CC - CE HEN doc Part number 97633571

BE>THINK>INNOVATE **GRUNDFOS**

Statement of conformity to the Norms

Product Denomination	Product Number
Customer Name	Serial Number
Customer Order Nr.	Grundfos Order Nr.

We Grundfos declare that the pumping set for water supply to fire-fighting systems indicated above is made in compliance with the requirements from the following reference Standards.

- **UNI EN 12845** Sprinkler automatic systems
- **UNI 10779** Hose reel and Hydrant systems
 - gear-operated valves for sizes larger than DN 100,
 - possibility of automatic stop for the main pumps.
- **UNI 11292** Compartments for installations of fire fighting pumping sets
 - diesel pump fuel tank which prevents dispersion in the case fuel leakage should occur,
 - diesel pump fuel tank with connection for the venting pipe,
 - hand pump for refilling the fuel tank when the supply point is at a height above 1.5 meters or exceeding 50 liters of capacity,
 - other elements compatible with installation requirements.
- **<CE> Mark**
The <CE> marking applied on the Hydro EN Series pumping sets states the compliance with the provisions of the following directives:
 - Machinery (new release: 2006/42/EC) which prescribes the essential safety requirements,
 - Electromagnetic compatibility (2004/108/EC),
 - Electrical equipment designed for use within certain voltage limits (2006/95/EC).

Grundfos is not liable for any modifications that should occur after the delivery of the product.

➤ **ISO 9000 Certification**
The Hydro EN pumping sets are manufactured by Grundfos pumps Italy which is a ISO 9000 certified company. This certificate proves that the company operates within a total quality assurance system, which is also approved specifically for "study, tailoring and assembly of pumping systems".

Grundfos Pompe Italia Srl
Date: 25/02/10

CC - Conformity HEN_GB Part number 97633571

➤ Certification ISO 9000

The Hydro EN pumping sets are manufactured by Grundfos pumps Italy which is a ISO 9000 certified company.

This certificate proves that the company operates within a total quality assurance system, which is also approved specifically for "study, tailoring and assembly of pumping systems".

CSQ **I-Net**

CERTIFICATO N. 9101.GRUN
CERTIFICATE N. 9101.GRUN

SI CERTIFICA CHE IL SISTEMA QUALITÀ DI
WE HEREBY CERTIFY THAT THE QUALITY SYSTEM OPERATED BY
GRUNDFOS POMPE ITALIA SRL

VIA GRAN SASSO 4 - 20090 TRUCCAZZANO (MI)
LIMITI OPERATIVE OPERATIVE LIMITS
VIA GRAN SASSO 4 - 20090 TRUCCAZZANO (MI)
Filiale di Roma
VIA ALTOMONTE 11 - 00173 ROMA (RM)
E' CONFORME ALLA NORMA
IS IN COMPLIANCE WITH THE STANDARD
ISO 9001:2000
PER LE SEGUENTI ATTIVITÀ:
FOR THE FOLLOWING ACTIVITIES
Studio, personalizzazione ed assemblaggio di sistemi di pompaggio su progettazione sviluppata e validata dalla Funzione Regionale Grundfos. Commercializzazione ed assistenza di pompe e sistemi di pompaggio per il prelievo e movimentazione dell'acqua e dei fluidi in genere.
Study, tailoring and assembly of pumping systems designed, developed and validated by the Grundfos Regional Department. Sales of and after-sales service for pumps and pumping systems for the extraction and movement of water and liquids in general.
Riferirsi al manuale della qualità per l'applicabilità dei requisiti della norma ISO 9001:2000
Refer to quality manual for details of application to ISO 9001:2000 requirements

IL PRESENTE CERTIFICATO È SOGGETTO AL RISPETTO DEL REGOLAMENTO PER LA CERTIFICAZIONE DEI SISTEMI DI QUALITÀ E DI GESTIONE DELLE AZIENDE
THE USE AND THE VALIDITY OF THE CERTIFICATE SHALL SATISFY THE REQUIREMENTS OF THE RULES FOR THE CERTIFICATION OF COMPANY QUALITY AND MANAGEMENT SYSTEM

PRIMA EMISSIONE	EMISSIONE CORRENTE	DATA SCADENZA
2002-07-31	2008-06-16	2011-07-30

Truccazzano

NO 8 s.p.a. - VIA GURTTIARNO, 43 - 20138 MILANO (ITALY)

SINCERT EA 15
Certificazione di Qualità
Certification of Quality

IL CERTIFICATO È VALIDO PER UN PERIODO DI VALIDITÀ DI CINQUE ANNI A CONDIZIONE CHE IL CLIENTE MANTIENGA IN CONDIZIONE IL SISTEMA DI GESTIONE DELLA QUALITÀ E CHE IL CERTIFICATO SIA RINNOVATO PERIODICAMENTE.
THE CERTIFICATE IS VALID FOR A PERIOD OF FIVE YEARS PROVIDED THAT THE CLIENT MAINTAINS THE QUALITY MANAGEMENT SYSTEM IN ORDER AND THAT THE CERTIFICATE IS RENEWED PERIODICALLY.

CESQA **CSQ**

➤ Functional diagram

The functional diagram beside represents the standard execution of the 2 pumps Hydro EN set, typically: with an electric + a diesel + a jockey pumps.

- ① Eccentric cone with controlled taper plus vacuum gauge
- ② Pressure gauge on discharge
- ③ Flow meter
- ④ By-pass line connection
- ⑤ Priming circuit connection
- ⑥ Check valve
- ⑦ Pump starting device
- ⑧ Connection water supply to the pump room sprinkler net
- ⑨ Pressure diaphragm tanks
- ⑩ Suction connection
- ⑪ Discharge connection to the system

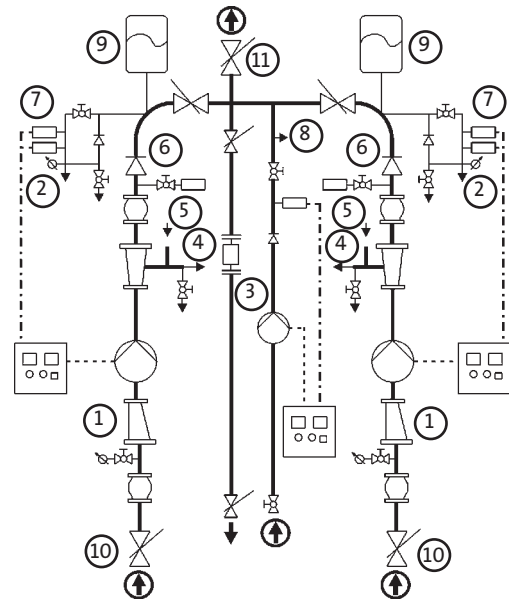

➤ PN16 construction

The components and structure of the Hydro EN pumping sets are in class PN 16, to meet the following conditions:

- Hydrostatic testing of the system for at least two hours at 1.5 times the operating pressure with a minimum of 15 bar (19.1.1.2),
- rated pressure of the system components not lower than 1.2 MPa (UNI 10779, 6.1).

➤ Suction Kit

The criterion from the Standard is that the water can flow effectively into the pump. The reference values are:

- velocity of the intaken water within 1.8 m/s in case of installation with positive inlet head (10.6.2.2),
- velocity of the intaken water within 1.5 m/s in case of suction lift installation (10.6.2.3).

The components of the suction kits of the Hydro EN sets are designed as to secure the size of the suction connection fulfils the more stringent of the criteria above.

The diverging cone with 20° taper (10.6.2.1) is used to prevent accumulation of any air collected along the suction piping.

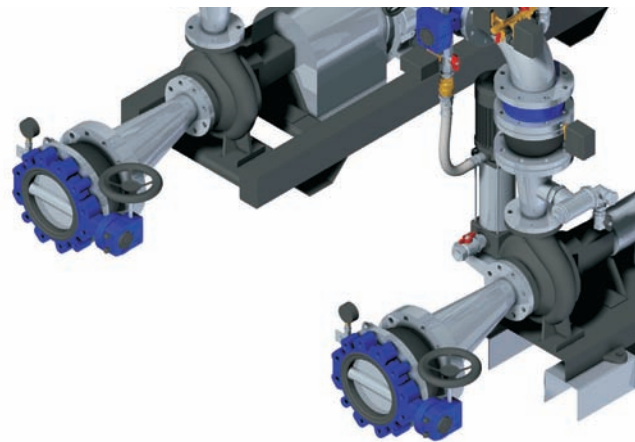

➤ Spacer coupling and back pull out design

In the horizontal axis pumps, the coupling between the pump and motor must allow each of these parts can be removed independently of the other and that the pump components can be inspected or serviced without having to disconnect the suction or discharge pipes (10.1).

To realize these conditions, a spacer coupling is used.

The end suction pumps should have the rotating part removable towards the motor (back pull-out design) (10.1).

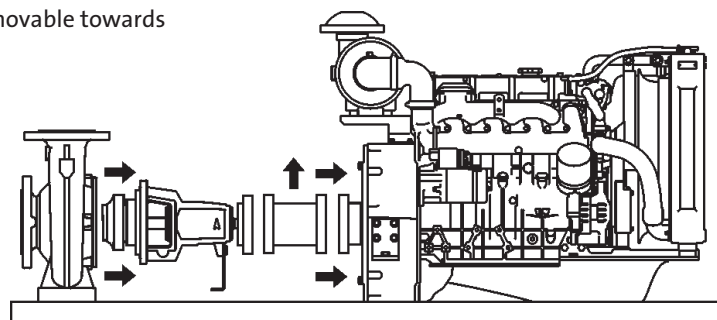
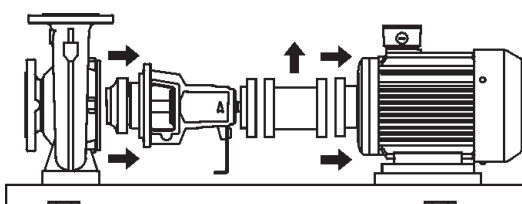

➤ Shape of the curve

The Q-H characteristic curve of the pumps is stable (10.1).

➤ Motor power size

The drivers must be able to deliver the power corresponding to one of the following two conditions:

- the maximum power required in case of “non overloading” curve (10.1.a) (in such a case the peak of power can occur inside or outside the working area of the curve published), or
- the power required at the flow corresponding to the NPSHR of 16m (10.1.b).

The pumps of the Hydro EN pumping sets correspond to the latter condition.

Diesel engines have to be able to operate continuously at full load and at an altitude of installation, with a power output in accordance with ISO 3046.

➤ NPSH available

The friction loss in the suction line and the water level should allow the following condition from the standard:

$$NPSH_D \geq NPSH_R + 1 \text{ [m]} \text{ (10.6.2.1)}$$

The transversal line through the Q-H curves indicates the limit of the working area generally allowed, although the analytical proof of the suction capability is always recommended. Duty points on the right of that line (for example in case of positive inlet head installations) can be chosen if confirmed by the design calculation.

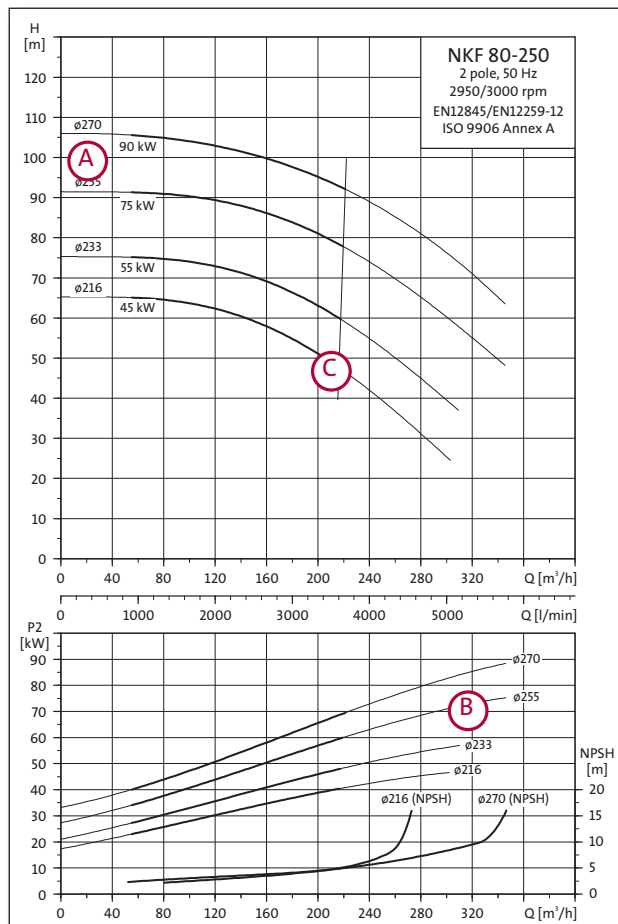

➤ Pressure maintenance pump

The jockey pump avoids unjustified starting of the main pumps.

But it must have such a limited flow performance to be not able to supply even a single sprinkler, if opened (10.6.2.5).

Thus, in the case of real need, always the start of the main pump must be caused.

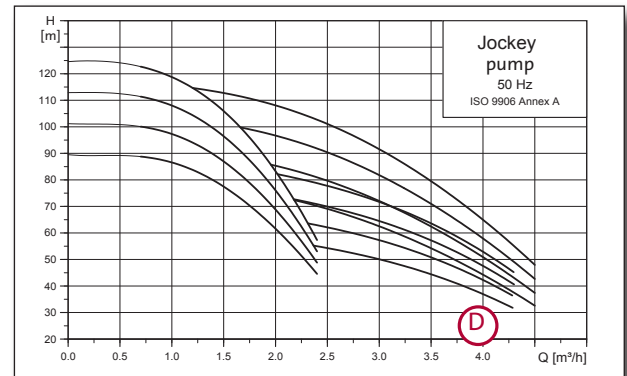

➤ Diesel driven pump factory test

A factory functional test is performed and data are reported on a test bulletin (10.9.13.1).

➤ Diesel engine cooling

The cooling of the Hydro EN diesel driven pump is by:

- direct air flow (10.9.3.d) for lower power sizes,
- water and heat exchanger (10.9.3.b), for power sizes of 30 kW onwards.

The latter solution allows proper operation, as independent as possible from the heat disposal condition in the installation room (UNI 11292, 5.4.2.1).

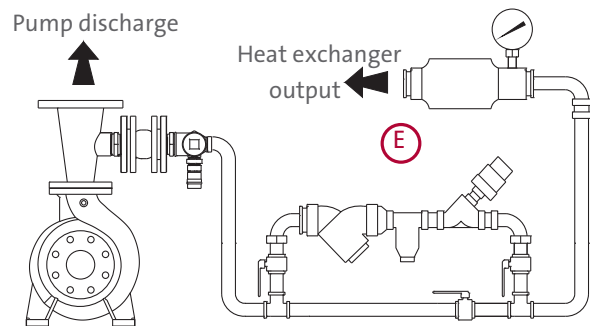

➤ Fuel tank

The tank of the diesel pump is equipped with a containment wall that prevents dispersion of fuel in the case of leakage (UNI 11292, 7.2; 7.3).

➤ Pump tank filling

For diesel pumps with tank refilling point at a height exceeding 1.5 m or above 50 lt. volume, a hand pump to refill the fuel tanks is included in the standard scope of supply (UNI 11292, 7.2; UNI 10779, 7.3).

➤ Tank vent

The tank of the diesel pump is equipped with a connection for the vent pipe to be carried out of the installation room (UNI 11292, 7.4).

➤ Automatic operation

When the discharge pressure drops (opening of exits), the pressure switches automatically start in the cascade sequence: the jockey pump, the first main pump, and, if necessary, and if present in the pumping set, the second main pump.

The jockey pump prevents unjustified starting of the main pumps, by automatically restoring the pressure in fire fighting system in case of leakage, but not in case of opening of a sprinkler (10.6.2.5).

The first main pump starts automatically in case of demand, thus providing the performance foreseen in the pump selection.

The second main pump, if present, is for backup as to secure anyhow, in case of need or lack of power mains (when the second main pump is diesel driven), the water to the fire fighting system to which the pumping set is connected.

The jockey pump is the only one which stops automatically by its pressure switch when the discharge pressure reaches the cut off value.

The main pumps can only be stopped manually by using the appropriate button on the panel. For application with hose reel or hydrants systems, the stop can be automatic by a timer, which is available on request (UNI 10779, A.1.2).

Appropriate selectors "AUT-0-TEST", always allows the start and stop of each pump at any time.

➤ Test mode of operation

In accordance with the requirements of the UNI EN 12845 Standard, the pumping units must be tested periodically for measuring of the performance delivered (20.3.4.2).

In this case the main pumps have to be tested one at a time, by simulating a discharge pressure drop, and opening the flow rate measuring loop, with consequent water flowing through the meter.

By using the throttling valve downstream of the flowmeter, the flow in transit in the test loop can be adjusted to the design value.

Therefore, It is possible to measure the following parameters:

- FLOW - by the flowmeter and the measuring loop,
- PRESSURE - both on suction and discharge through appropriate vacuum and pressure gauges,
- CURRENT through ammeter.

And also, related to the diesel pump:

- DIESEL ENGINE RPM,
- WORKING HOURS,
- ENGINE TEMPERATURE,
- OIL PRESSURE,
- FUEL LEVEL,
- BATTERIES VOLTAGE.

Lay-out of parts allows an immediate reading of the measurement instruments and signals, for ease of operations during both commissioning and the periodic test routine.

➤ Motor starting

The motor starting methods are of the following types:

- Direct On Line (DOL) for power sizes up to 30 kW included,
- Star/Delta (SD) from 37 kW included and upwards.

The version with starting method different than the standard described above is available on request.

The starting of the diesel engine is provided by two DC batteries, whose charge is constantly assured by dedicated electronic devices.

At each starting request, a dedicated electronic circuit, allows the alternate use of the two batteries and the automatic exclusion of the failing battery, if any.

➤ Signalling

To the control panels of the main pumps it must be connected a remote alarm unit (see accessories), installed in a permanently manned location, which is equipped with audible and visual signals according to the state of the pumping unit (10.8.6.2; 10.9.11; UNI 10779, A.1.5).

To this purpose, the control panel of the main pumps have the following outputs available in the terminal blocks (10.8.6.1; 10.9.11).

Diesel control panel:

- mode of operation not in automatic,
- pump starting failure,
- pump running,
- diesel control panel fault.

Electric pump control panel:

- voltage available to the motor,
- pump start request,
- pump running,
- pump starting failure,
- power mains failure.

► Parts layout

The following drawing is representative of the standard configuration of the Hydro EN set with 2 pumps. Different executions are available on request.

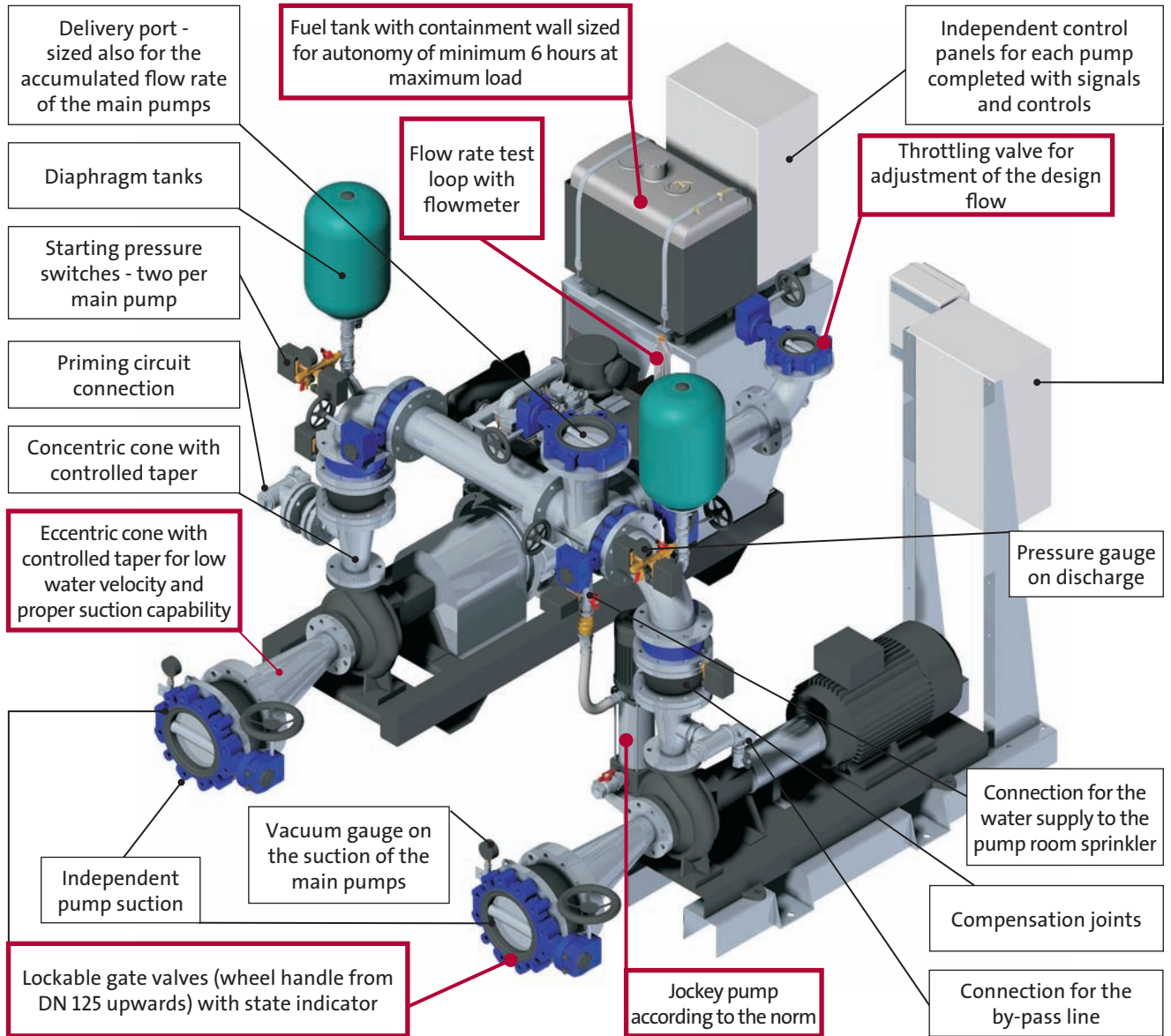

► Scope of delivery

The concept of modular construction applied to the Hydro EN range will facilitate the operations of transport, handling and positioning in the place of installation. All the pumping sets are divided into macroblocks and normally:

- a baseframe that houses the main pump, the jockey pump, the respective control panels with brackets, the flow rate test loop, with its flowmeter and throttling valve and all the related hydraulic components,
- in the case of pumping sets with two main pumps, the second macroblock includes a second baseframe that houses the second main pump, its control panel with brackets and all related hydraulic components.

Example of a single pumping unit

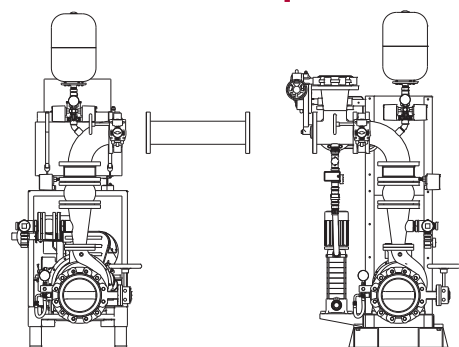

Example of a pumping set with two pumps

Prerogatives and advantages

- The Grundfos fire-fighting Hydro EN pumping sets are conceived as a complete, robust and compact package.
- The modular structure of sets comprising two or more pumping units enables them to be separated into macroblocks for easy handling and positioning.
- Installation is made easier by its rational design.
- The features that distinguish the Grundfos Hydro EN sets and the resulting advantages are here summarised (compliance with the various points of the reference UNI EN 12845 Standard, if not otherwise stated, are indicated into parenthesis).
- The intended mode of operation is automatic start by means of pressure-switches and manual stop (10.9.5.2; 10.9.7.1). The automatic stop is optional (UNI 10779, A.1.2).

Reliable

- Connections sized for low velocity of intaken water and correct suction capability (10.6.2.2; 10.6.2.3).
- Eccentric cone connection with controlled taper (10.6.2.1) for disposing of any air that may have been collected in the piping.
- Diffuser cone on the discharge side (10.5) for managing the output flow with low friction loss components.
- NPSH of the pump within regulation limits (10.6.2.1) to safeguard a correct suction capability
- Lockable gate valves with state indicator (15.2; UNI 10779, 7.4.3) and wheel handle from DN 125 upwards (UNI 10779, 6.3).
- Diesel engines cooled by a heat exchanger (10.9.3) for power sizes above 30 kW, allowing engine operation, as independent as possible from the heat disposal condition in the installation room (UNI 11292, 5.4.2.1).
- Metal pipes for diesel oil (10.9.6).
- Start-up of diesel engine with automatic sequence of six attempts and battery switching (10.9.7.2).

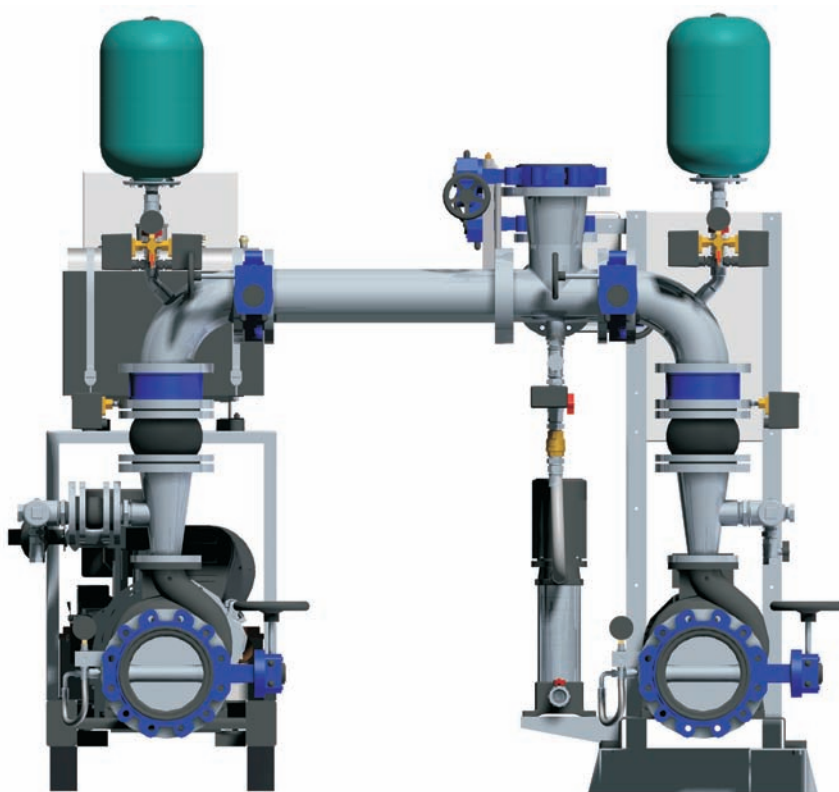

Complete

- Provided with a 50 mm fitting for connection to a priming tank (10.6.2).
- Equipped with a connection for water supply to the sprinkler protecting the installation room (10.3.2).
- Factory set pressure-switches (10.7.5.2).
- Muffler with industrial type silencer (10.9.5) always supplied together with the diesel engine.
- Kit of spares for diesel engines as mentioned by the standards (10.9.12) available on request.
- Jockey pump so as to avoid unjustified starting of the duty pumps (10.6.2.5).
- Supplied with pre-charged pressure tanks for proper jockey pump operation.
- Flow rate test loop with throttling valve for reading of the design performance values (8.5; 8.5.1.b) included in the standard scope of supply.
- Hand pump to refill the fuel tanks for diesel pumps with tank refilling point at a height exceeding 1.5 m or above 50 l volume (UNI 11292, 7.2; UNI 10779, 7.3).
- Automatic stop function, for hose reel and hydrants systems only (UNI 10779, A.1.2) available on request.
- Priming tank with the prescribed equipment (10.6.2.4) available on request.
- Availability of remote alarm signalling unit (10.8.6.2) with siren and suitably coloured signalling lamps (10.8.6.3).

- The configurations proposed for the main pumps are: 1 or 2 electric pumps, 1 electric + 1 diesel pumps, 1 or 2 diesel pumps (10.2). Sets with 3 pumps are manufactured on request. The jockey pump prevents unjustified starting of the main pumps.
- The lay-out of the parts and the completeness of the functions facilitate the periodic checking and testing routine operations to be performed during the operational life (20.2).

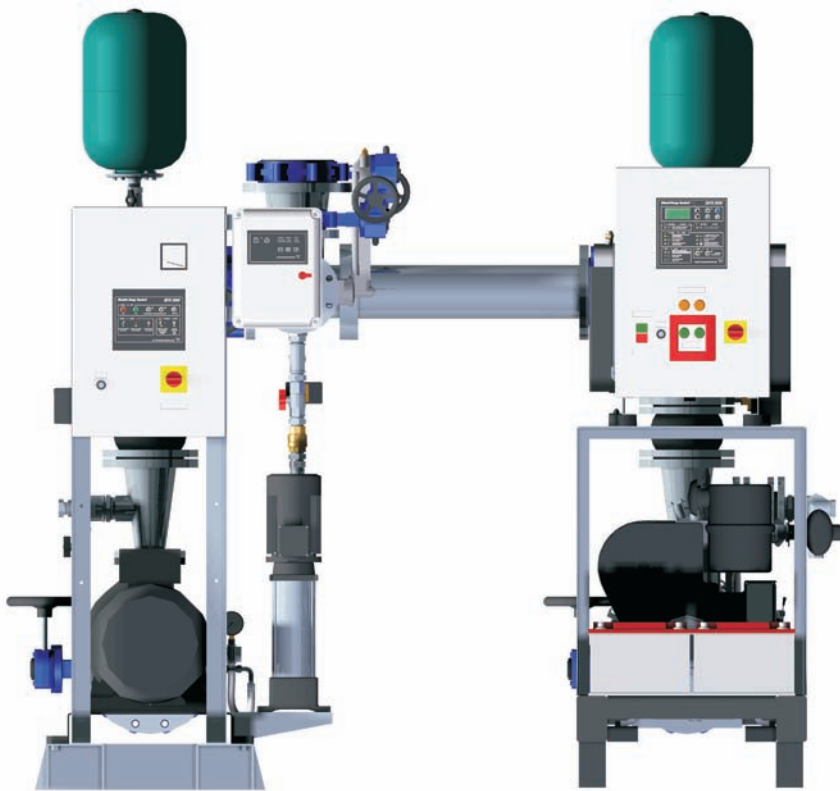

Easy routine checks

- Alarms displayed with different designated coloured lamps depending on the type of warning (10.9.11).
- LCD display 62x25 mm with 4 rows and 16 digits for simultaneous visualization of 8 system parameters.
- Test device for checking the signalling lamps (10.8.6.4).
- Selective check of pressure-switches with individual testing (10.7.5.3).
- Sensors and/or measuring devices installed at the relevant points of the pumping engine (10.9.7.1; 10.9.13.1).
- Test devices easily accessible for routine checks (20.2).
- Reading of performance with effective measurement of capacity and pressure, the latter on both the discharge and the suction sides of the duty pumps (10.9.13.1).
- Easy adjustment for measurement of the design flow rate.
- Kit of switches to monitor the state of the main gate valves (D.3.4; H.2.2; UNI 10779, 7.4.3).

Safe

- By-pass output for the recirculation of partial flow to prevent overheating of the pump in case of operation against closed valve and/or flow for cooling the diesel engine; relevant and proper flow rates stated beside the duty performance of the pumping set (10.5).
- Two start-up pressure switches for each main pump, hydraulically connected by a single piece device with built-in complementary components (10.7.5.1; Figure 6 ref. 10).
- Jockey pump so as to avoid unjustified starting of the main pumps, with such a limited flow performance to be not able to supply even a single sprinkler, if opened (10.6.2.5).
- Operating conditions of the duty pumps fully displayed by the control panel (10.8.6.1).
- The signals of the operating conditions can be entirely transferred remotely and specific alarms can be handled individually (10.8.6.2).
- Cooling pump of diesel engine driven by a double belt (10.9.3).
- Adequate capacity of diesel oil tank sized for minimum 6 hours of operation (10.9.6).
- Indication of a 25% drop in the level of the fuel (Appendix H 2.4).
- ON/OFF controls for diesel driven pumps have independent circuits and separate relays (10.9.7.1).
- Diesel driven pump control panel powered simultaneously by two batteries (10.9.7.2).
- Automatic exclusion of the failed battery, if any, so as not to spoil the other one as well (10.9.7.2).
- Emergency start-up of the diesel driven pump by a push-button for each battery behind a glass panel (10.9.7.3).
- Push-button and signalling lamp for manual testing of the diesel driven pump (10.9.7.4).
- One battery charger for each battery to ensure operational back-up (10.9.9).
- Controlled-recharge battery charger for steady performance and long battery life (10.9.9).
- Test bulletin with performance and characteristic data of diesel driven pumps, as mentioned by the standards (10.9.13.1).
- Tank of the diesel pump equipped with a containment wall that prevents dispersion of fuel in the case of leakage (UNI 11292, 7.2; UNI 10779, 7.3).
- Tank of the diesel pump equipped with a connection for the vent pipe to be carried out of the installation room (UNI 11292, 7.4).

97633592 4411	GB

GRUNDFOS POMPE ITALIA s.r.l.

SEDE: Via Gran Sasso, 4 - TRUCCAZZANO (MI)

Tel. 0295838112 (r.a. 10 linee) - Fax 0295309063

Fax 0295367421 (informazioni tecniche / offerte)

Fax 0295367486 (servizio assistenza)

www.grundfos.it