

LGP15-A Petrol engine pump

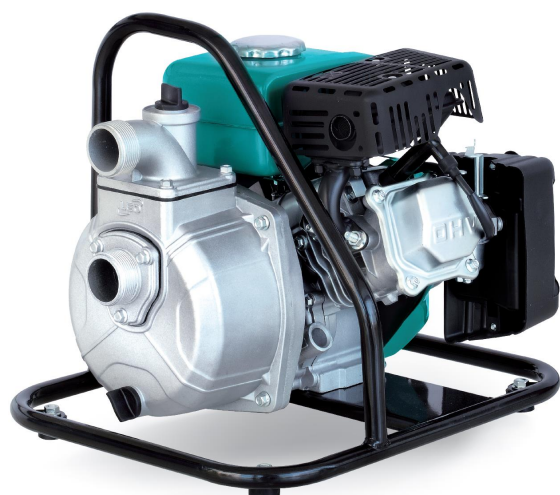

Application

- Transfer of clean water at a temperature between 0 and 40 ° C
- Usable for water supply and drainage for factories, mines, public facilities as well as for irrigation

Pompe

- Powerful and efficient 4-stroke engine
- Easier start-up, more complete combustion, low consumption, increased respect for the environment
- Better sealing thanks to a specific mechanical seal
- Turbine design for high hydraulic efficiency
- Rust protected cast iron impeller and diffuser (cataphorèse)
- Maximum suction at 5 m, priming time at 5 m of 2 min
- 38 mm suction and blowing

Moteur

- Single cylinder, 4-stroke, air-cooled
- Maximum power 2 CV
- Engine cylinder capacity: 87 cm³
- Rotation speed: 3600 rpm

Identification codes

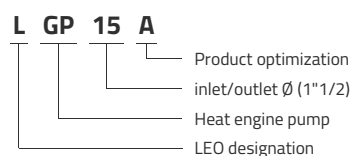

Technical data

MODEL	kW	Q (m ³ /h)																			
		0	2	4	6	8	10	12	14	16	18										
LGP15-A	2.25	0	33	67	100	133	167	200	233	267	300	0	25	24.8	23	22	20	17	15	12	7.2

Dimensions

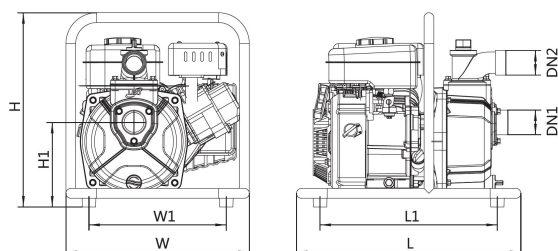

MODEL	DN1	DN2	L	W	H	L1	W1	H1
LGP15-A	1 1/2	1 1/2	438	358	377	346	268	164.2

Exploded view

No.	Type	Materials
1	frame	steel
2	engine	
3	pump bottom	aluminium
4	O-ring	nitrile rubber (NBR)
5	Mechanical seal	carbon / ceramic
6	Impeller	cast iron HT200
7	diffuser	cast iron HT200
8	O-ring	nitrile rubber (NBR)
9	Pump body	aluminium
10	seal	nitrile rubber (NBR)
11	plug	polypropylene
12	outlet fitting	aluminium
13	non-return valve	nitrile rubber (NBR)
14	inlet fitting	aluminium

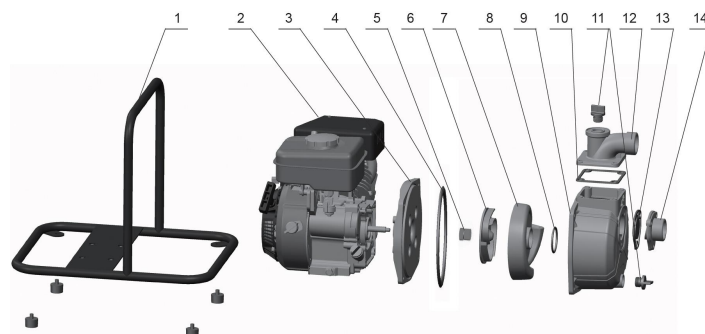

Packaging

MODEL	Weight (kg)	Length L (mm)	Width W (mm)	Height H (mm)
LGP15-A	15.5	464	378	400

