

# HL130M Dri-Prime® Pump

The Godwin Dri-Prime HL130M pump is an extremely powerful yet compact pump with flow capabilities to 340 m<sup>3</sup>/hr and discharge heads to 191 metres.

The HL130M features the unique Godwin high pressure oil bath mechanical seal design. This allows for dry running for prolonged periods while automatically priming and repriming. Able to perform in the toughest conditions, the HL130M can handle solids up to 22 mm in diameter. This makes it an extremely effective pump, suitable for both slurry and clean water applications. The powerful HL130M has proven itself a pump of choice for mines, quarries and many other high capacity applications.



## Features and Benefits

- Fully automatic priming from dry to 8.5 metres suction lift.
- Godwin Dri-Prime is a continuously operated Venturi air ejector priming device which requires no periodic adjustment or control.
- Extensive application flexibility. It will handle sewage, slurries and liquids with solids up to 22 mm in diameter.
- Dry-running high pressure oil bath mechanical seal, with high abrasion resistant silicon carbide faces.
- A Close-coupled centrifugal pump with Godwin Dri-Prime system mounted to a diesel engine or electric drive.
- All cast iron construction (stainless steel construction option available) with cast steel impeller.
- Also available as Hush-Pac or as a bareshaft pumpend.
- Standard build engines; Caterpillar C9, Volvo TAD950VE, Volvo TAD951VE. Other engine options are available.

## Specifications

Suction connection	150 mm (6" BS10 Table 'E')
Delivery connection	100 mm (4" BS EN 1092 PN25)
Max capacity	340 m <sup>3</sup> /hr
Max Head	191 metres
Max Solids handling	22 mm
Max Impeller diameter	514 mm
Max operating temp	80 °C
Max working pressure	18.8 bar
Max suction pressure	6.0 bar
Max casing pressure	28.3 bar
Max operating speed	2100 rpm

godwin   
a xylem brand

# Performance Curve

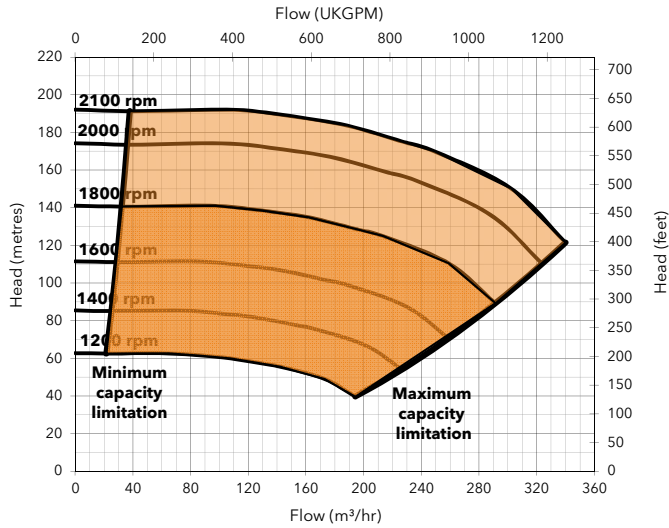

## Engine option 1

Price list ref - HL130M-01-DBO-001

Caterpillar, C9, 205.0 kW @ 2100 rpm

Impeller diameter 514 mm

Pump Speed 2100 rpm

### Suction Lift Table

Total Suction Head (metres)	Total Delivery Head (metres)				
	111	149	160	171	182
	Output (m³/hr)				
3.0	341	299	268	229	153
4.6	336	294	263	226	143
6.1	331	294	252	210	134
7.6	326	294	263	189	105

Fuel capacity (Full) 850 litres, (Usable) 690 litres

Fuel consumption @ 2100 rpm BEP 52 litres/hour

Weight: (Dry) 4,600 kg, (Wet) 5,331 kg

Dimensions: (L) 3,700 x (W) 1,700 x (H) 2,200 mm

Performance data provided in tables is based on water tests at sea level and 20°C ambient. All information is approximate and for general guidance only. Please contact the factory or office for further details.

# Materials

Pump casing & suction cover	Cast iron BS EN 1561 - 1997
Wearplates	High Chromium Cast Iron HC403:1977 Grade FR6252
Pump Shaft	Carbon steel BS EN 1561 - 1997
Impeller	Cast Steel BS3100 A5 Hardness to 200 HB Brinell
Non-return Valve body	Steel BS EN 1561 - 1997
Mechanical Seal Faces	Silicon carbide vs silicon carbide

## Engine option 2

Price list ref - HL130M-01-DBO-002

Volvo, TAD950VE, 181.0 kW @ 1800 rpm

Impeller diameter 514 mm

Pump Speed 1800 rpm

### Suction Lift Table

Total Suction Head (metres)	Total Delivery Head (metres)				
	79	107	115	123	131
	Output (m³/hr)				
3.0	293	257	230	196	131
4.6	288	252	225	194	122
6.1	284	252	216	180	115
7.6	279	252	225	162	90

Fuel capacity (Full) 850 litres, (Usable) 690 litres

Fuel consumption @ 1800 rpm BEP 35 litres/hour

Weight: (Dry) 5,000 kg, (Wet) 5,744 kg

Dimensions: (L) 3,700 x (W) 1,700 x (H) 2,200 mm

Performance data provided in tables is based on water tests at sea level and 20°C ambient. All information is approximate and for general guidance only. Please contact the factory or office for further details.

HL130M - Caterpillar C9

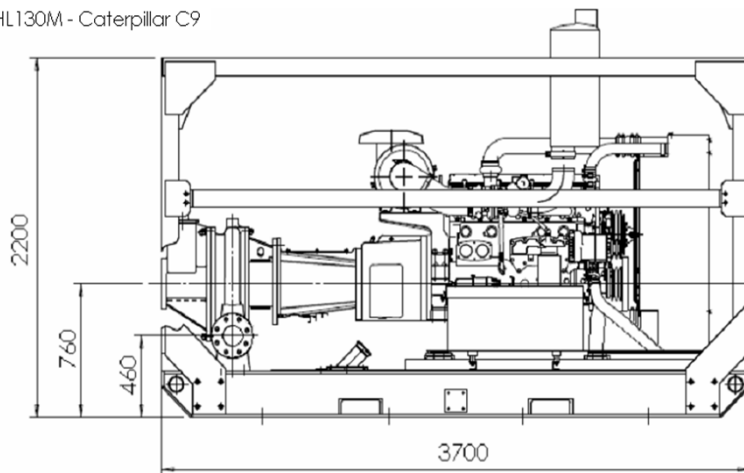
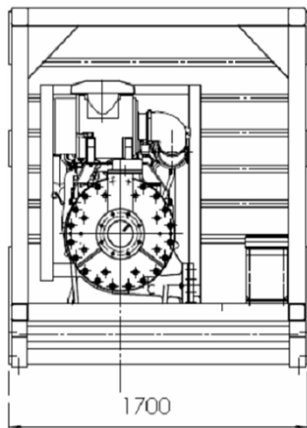

Xylem Dewatering Solutions UK Ltd  
 Quenington, Cirencester  
 Gloucestershire GL7 5BX, England  
 Tel: 01285 750271 Fax: 01285 750352



Assessed to ISO 9001:2008  
 Certificate N° 1027

Reference number : 95-1116-1000  
 Date of issue : 05 December 2012  
 Issue : 13

[www.godwinpumps.com](http://www.godwinpumps.com)