

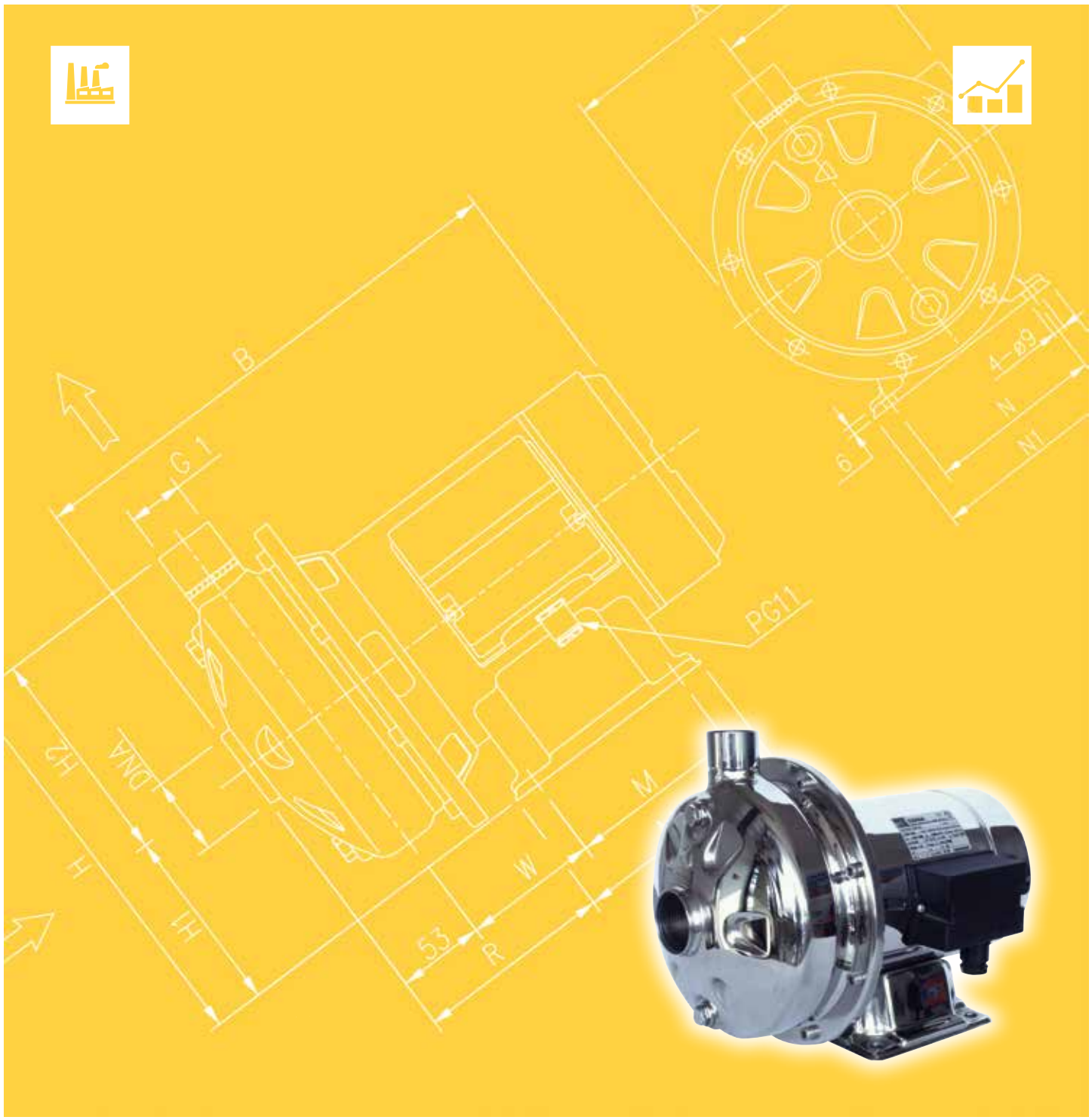

Japanese Technology since 1912

CD

Data Book 50Hz



	Page
- SPECIFICATIONS ^①	200
PERFORMANCE RANGE and SELECTION CHART	201
TYPE KEY	202
CURVE SPECIFICATIONS	203
PERFORMANCE CURVE CD 70	204
PERFORMANCE CURVE CD 90	205
PERFORMANCE CURVE CD 120	206
PERFORMANCE CURVE CD 200	207
- CONSTRUCTIONS	300
SECTIONAL VIEW CD 70/05-70/07-90/10	300
SECTIONAL VIEW CD 70/12-120/07-120/20	301
SECTIONAL VIEW CD 120/12-200/12-200/20-200/25	302
MECHANICAL SEAL	303
BEARINGS	305
- DIMENSIONS and WEIGHT	400
PUMP	400
PACKING	401
- TECHNICAL DATA	500
MOTOR DATA	500
NOISE DATA	500

① click INDEX to jump CORRESPONDING SECTION

② click  to go back to INDEX

SPECIFICATIONS

50Hz

Rev. Q

PUMP		
Liquid Handled	Type of liquid	Clean water
	Temperature [°C]	min. -5 max. +60 only for model 70/05, 70/07, 90/10 max. +60 for model 70/05, 70/07, 90/10 version: E, Q1AEGG, VAEGG, U3U3EGG, Q1U3EGG, U3CEGG max. +90 max. +110 H – HS - HW - HSW max. +120 E, Q1AEGG, VAEGG, U3U3EGG, Q1U3EGG, U3CEGG
Maximum working pressure [MPa]		0.8
Construction	Impeller	Closed centrifugal type
	Shaft seal type	Mechanical seal
	Bearing	Sealed ball bearing
Pipe Connection	Suction	G1"¼ (G1"½ CD 200) UNI ISO 228-1
	Discharge	G1" UNI ISO 228-1
Material	Casing	EN 1.4301 (AISI 304)
	Impeller	EN 1.4301 (AISI 304)
	Casing cover	EN 1.4301 (AISI 304)
	Shaft seal	Ceramic / Carbon / NBR(for special versions see page 303)
	Shaft	AISI 303 (Wet extension)
	Bracket	EN 1.4301 (AISI 304)
Applicable standard of test		ISO 9906:2012 – Grade 3B

MOTOR		
Type	Electric - TEFC	
	Single Phase	Three Phase
Efficiency level (Reg. 1781/2019)	-	IE3
No. of Poles	2	
Rotation speed [min ⁻¹]	≈ 2800	
Insulation Class	F	
Protection degree (CEI EN 60034-5)	IP 55	
Power rating	[kW]	0.37 ÷ 1.5
	[HP]	0.5 ÷ 2
Frequency [Hz]	50	
Voltage [V]	230 ±10%	230/400 ±10%
Capacitor	Built in	-
Over load protection	Built in	Provided by the user
Casing material	EN 1.4301 (AISI 304)	
Base material/motor support	EN 1.4301 (AISI 304)	
Dimensions of cable entry	PG11	

PERFORMANCE RANGE

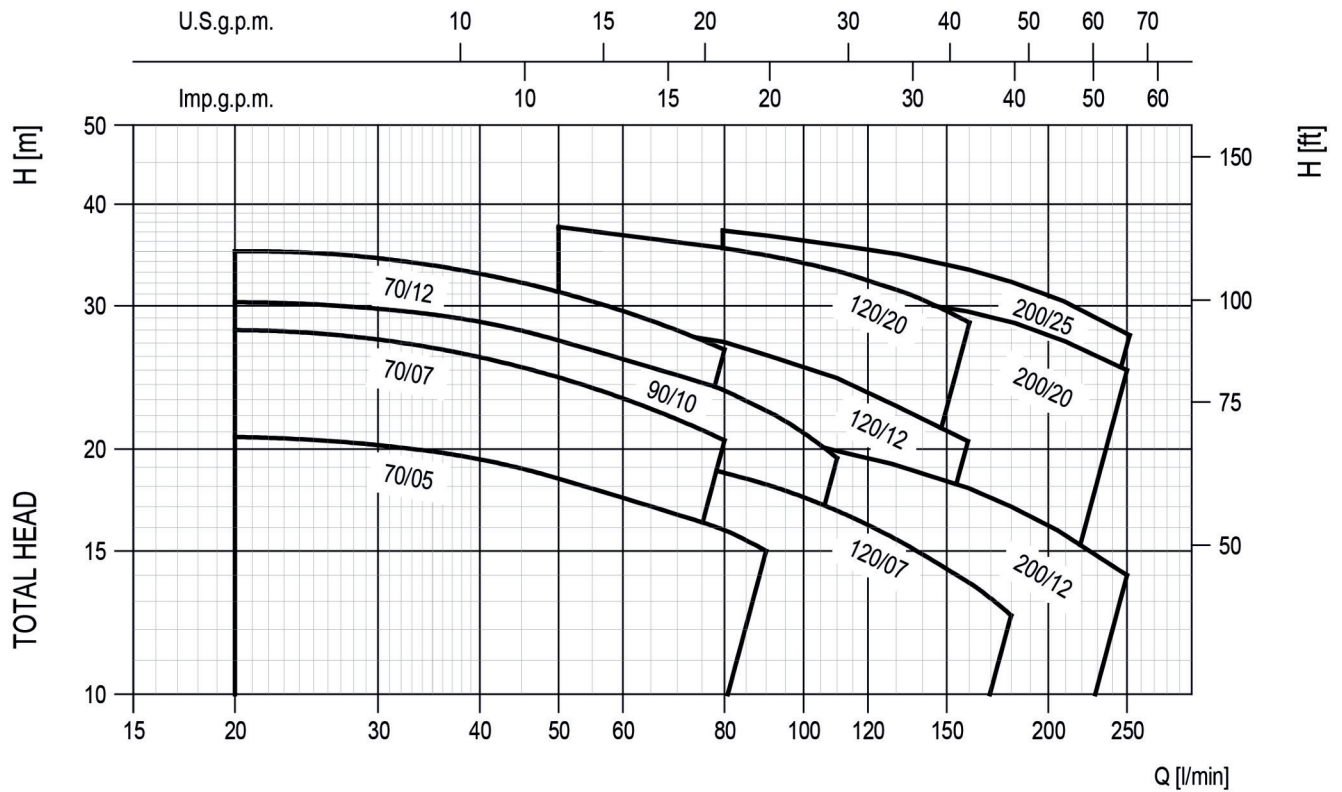

SELECTION CHART

Pump type		Power		Q=Capacity												
				l/min	0	20	50	80	90	110	130	160	180	210	250	
Single Phase	Three Phase	[kW]	[HP]	m ³ /h	0	1.2	3.0	4.8	5.4	6.6	7.8	9.6	10.8	12.6	15	
H=Total manometric head in meters																
CDM 70/05	CD 70/05	0.37	0.5	22	20.7	18.4	15.9	15	-	-	-	-	-	-	-	-
CDM 70/07	CD 70/07	0.55	0.75	30	28	24.5	20.5	-	-	-	-	-	-	-	-	-
CDM 70/12	CD 70/12	0.9	1.2	37	35	31.2	26.5	-	-	-	-	-	-	-	-	-
CDM 90/10	CD 90/10	0.75	1	32	30.3	27.2	23.6	22.3	19.5	-	-	-	-	-	-	-
CDM 120/07	CD 120/07	0.55	0.75	22.5	-	20.5	18.7	18.1	16.8	15.5	13.7	12.5	-	-	-	-
CDM 120/12	CD 120/12	0.9	1.2	31.2	-	29.3	27.5	26.8	25.2	23.6	21	-	-	-	-	-
CDM 120/20	CD 120/20	1.5	2	40.5	-	37.5	35.3	34.6	33.1	31.4	28.6	-	-	-	-	-
CDM 200/12	CD 200/12	0.9	1.2	22.8	-	-	21.3	21	20.4	19.7	18.5	17.6	16	14	-	-
CDM 200/20	CD 200/20	1.5	2	33	-	-	31.5	31.2	30.6	30	28.7	27.9	26.5	24.5	-	-
-	CD 200/25	1.8	2.5	39.4	-	-	36.8	36.5	35.6	34.7	33.3	32	30	27.2	-	-

TYPE KEY

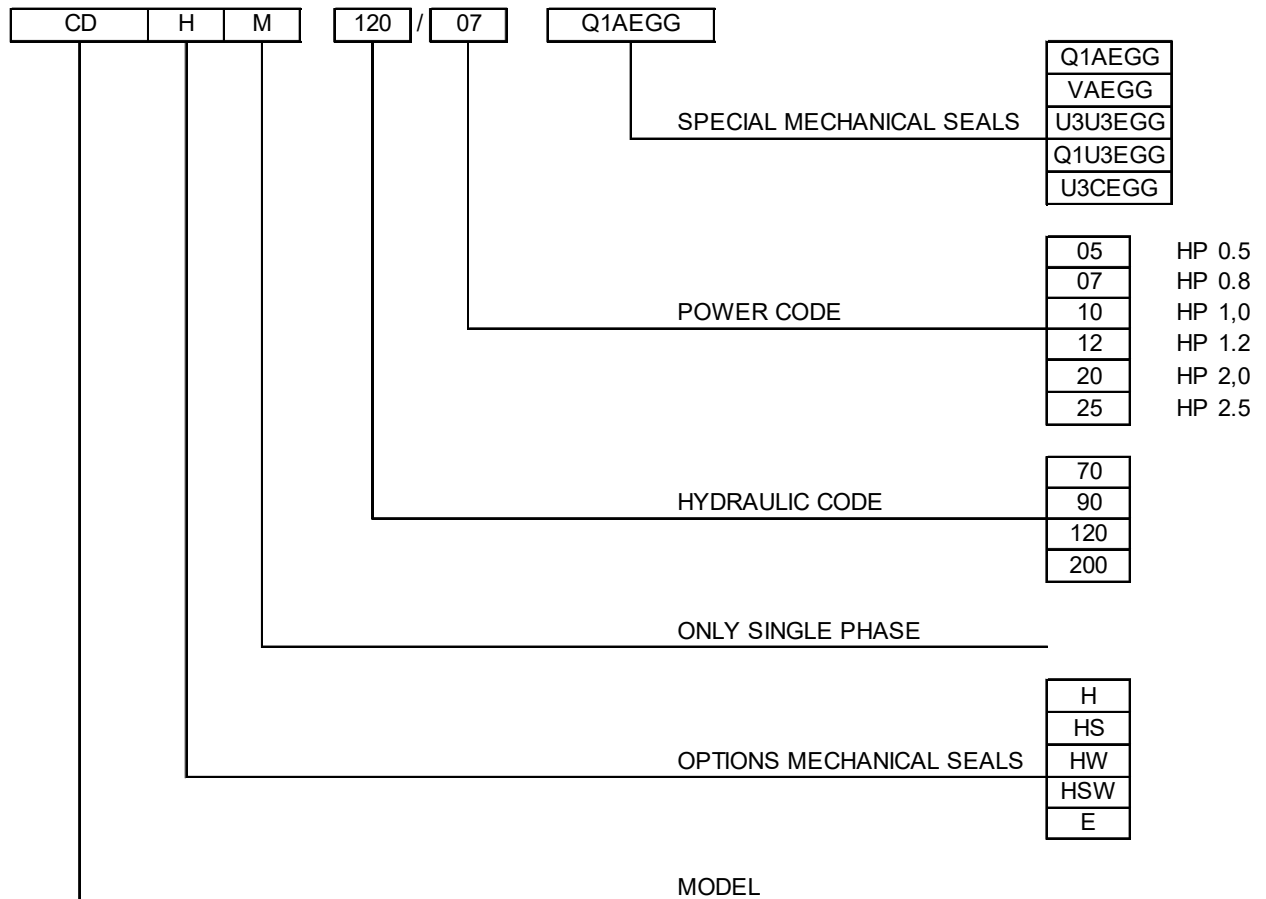

PERFORMANCE CURVE SPECIFICATIONS

The specifications below qualify the curves shown on the following pages.

Tolerances according to ISO 9906:2012 – Grade 3B

The curves refer to effective speed of asynchronous motors at 50 Hz, 2 poles.

Measurements were carried out with clean water at 20°C of temperature and with a kinematic viscosity of $\nu = 1 \text{ mm}^2/\text{s}$ (1 cSt)

The NPSH curve is an average curve obtained in the same conditions of performance curves.

The continuous curves indicate the recommended working range. The dotted curve is only a guide.

In order to avoid the risk of over-heating, the pumps should not be used at a flow rate below 10% of best efficiency point.

Symbols explanation:

- Q = volume flow rate
- H = total head
- P_2 = pump power input (shaft power)
- η = pump efficiency
- NPSH = net positive suction head required by the pump
- MEI = minimum efficiency index

The minimum efficiency index (MEI) is a measure of the quality of a pump size in respect to its mean efficiency. The minimum efficiency index is based on the hydraulic efficiency and on the head at the best efficiency point.

The efficiency of a pump with trimmed impeller is usually lower than that of a pump with the full impeller diameter. The trimming of the impeller will adapt the pump to a fixed duty point, leading to reduced energy consumption. The minimum efficiency index (MEI) is based on the full impeller diameter.

The operation of these water pumps with variable duty points may be more efficient and economic when controlled, for example, by the use of a variable speed drive that matches the pump duty to the system.

MEI = 0.4 for ESCC 2900 rpm

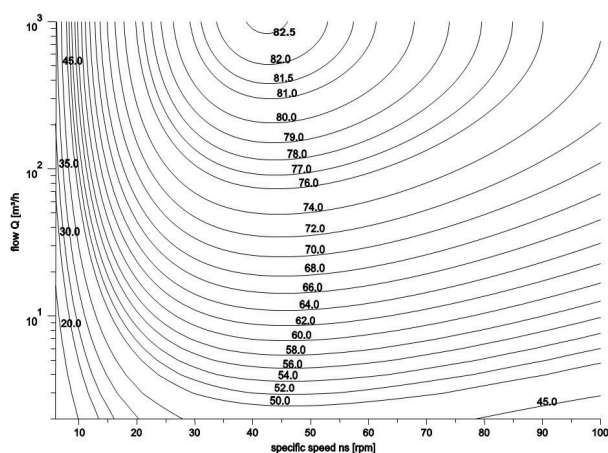

MEI = 0.7 for ESCC 2900rpm

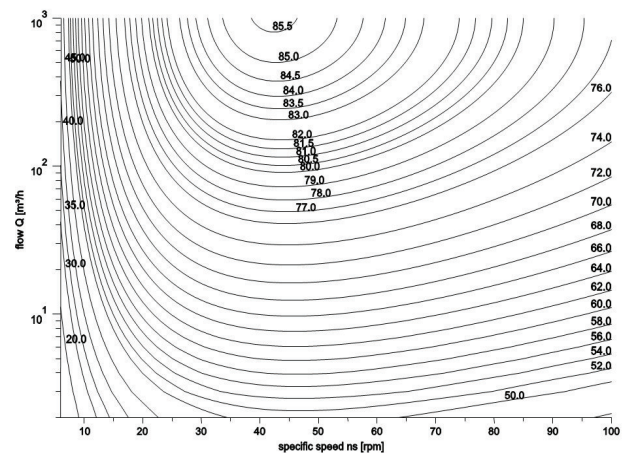

CD 70/05 (0.37 kW) - Impeller diameter = 132 mm
 CD 70/07 (0.55 kW) - Impeller diameter = 157 mm
 CD 70/12 (0.90 kW) - Impeller diameter = 176 mm

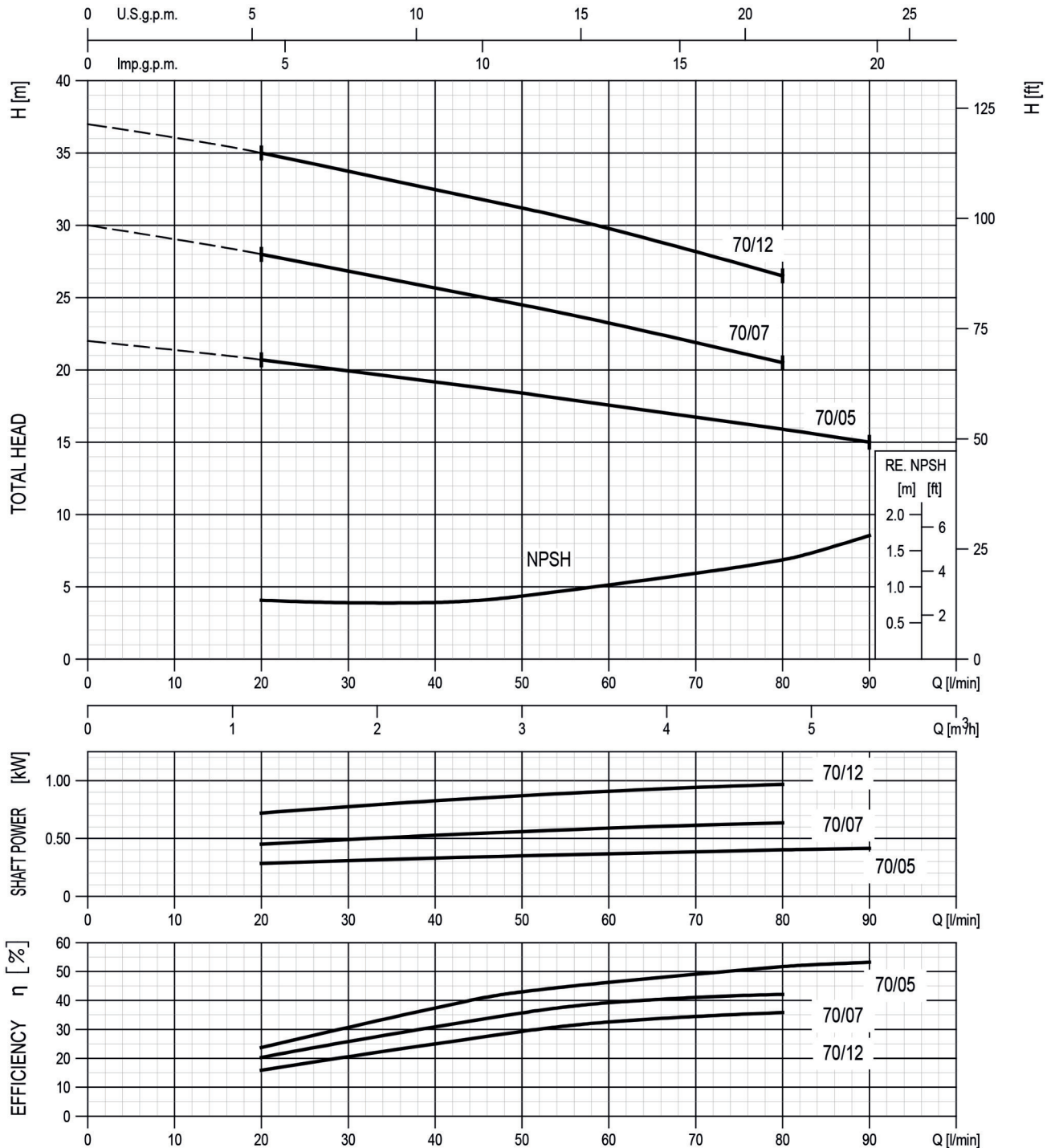

Rotation speed $\approx 2800 \text{ min}^{-1}$
 Test standard: ISO 9906:2012 – Grade 3B

CD 90/10 (0.75 kW) MEI > 0.50 - Impeller diameter = 157 mm

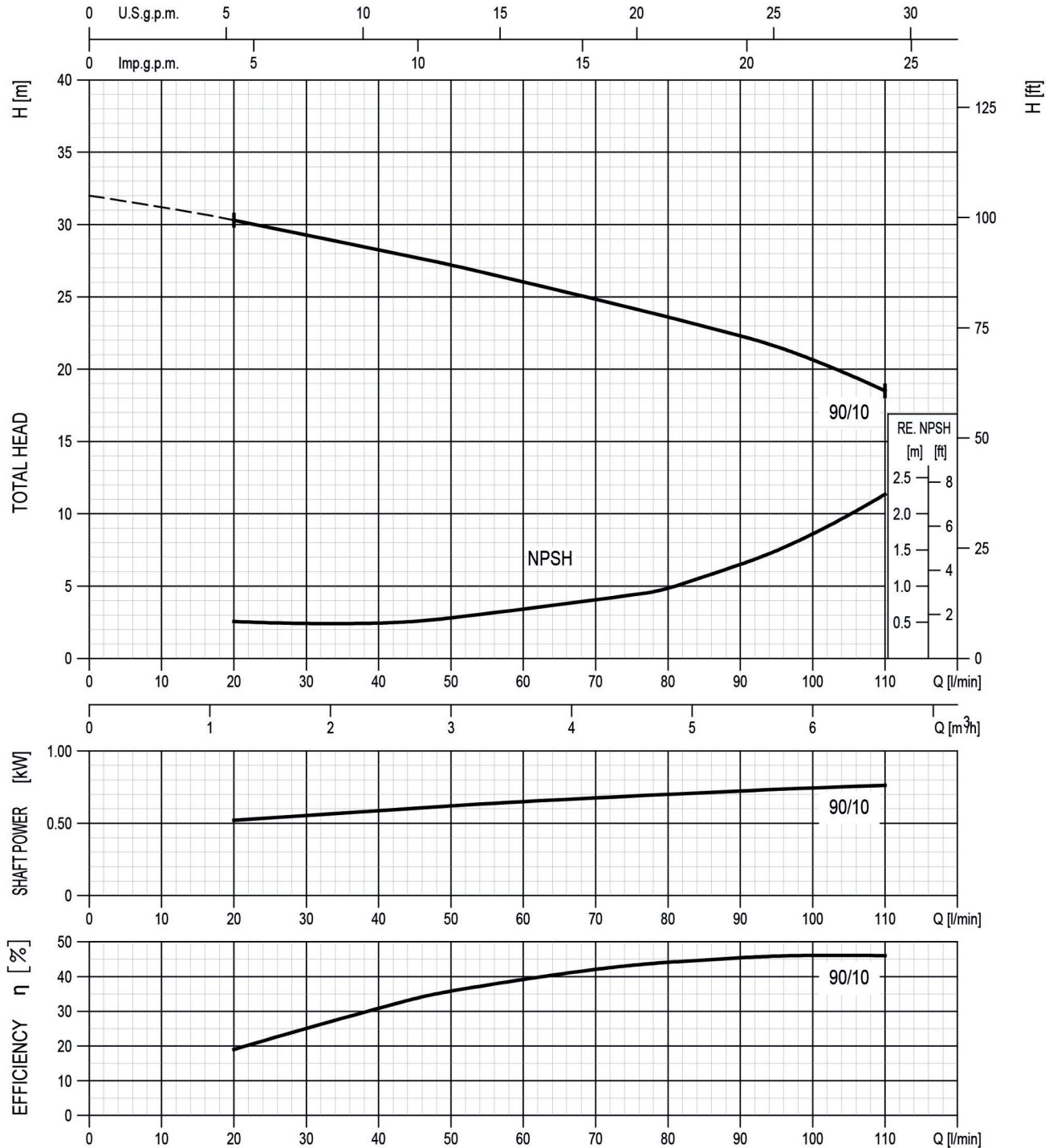

Rotation speed $\approx 2800 \text{ min}^{-1}$
 Test standard: ISO 9906:2012 – Grade 3B

CD 120/07 (0.75 kW) MEI > 0.50 - Impeller diameter = 132 mm
 CD 120/12 (0.90 kW) MEI > 0.40 - Impeller diameter = 157 mm
 CD 120/20 (1.50 kW) MEI > 0.40 - Impeller diameter = 176 mm

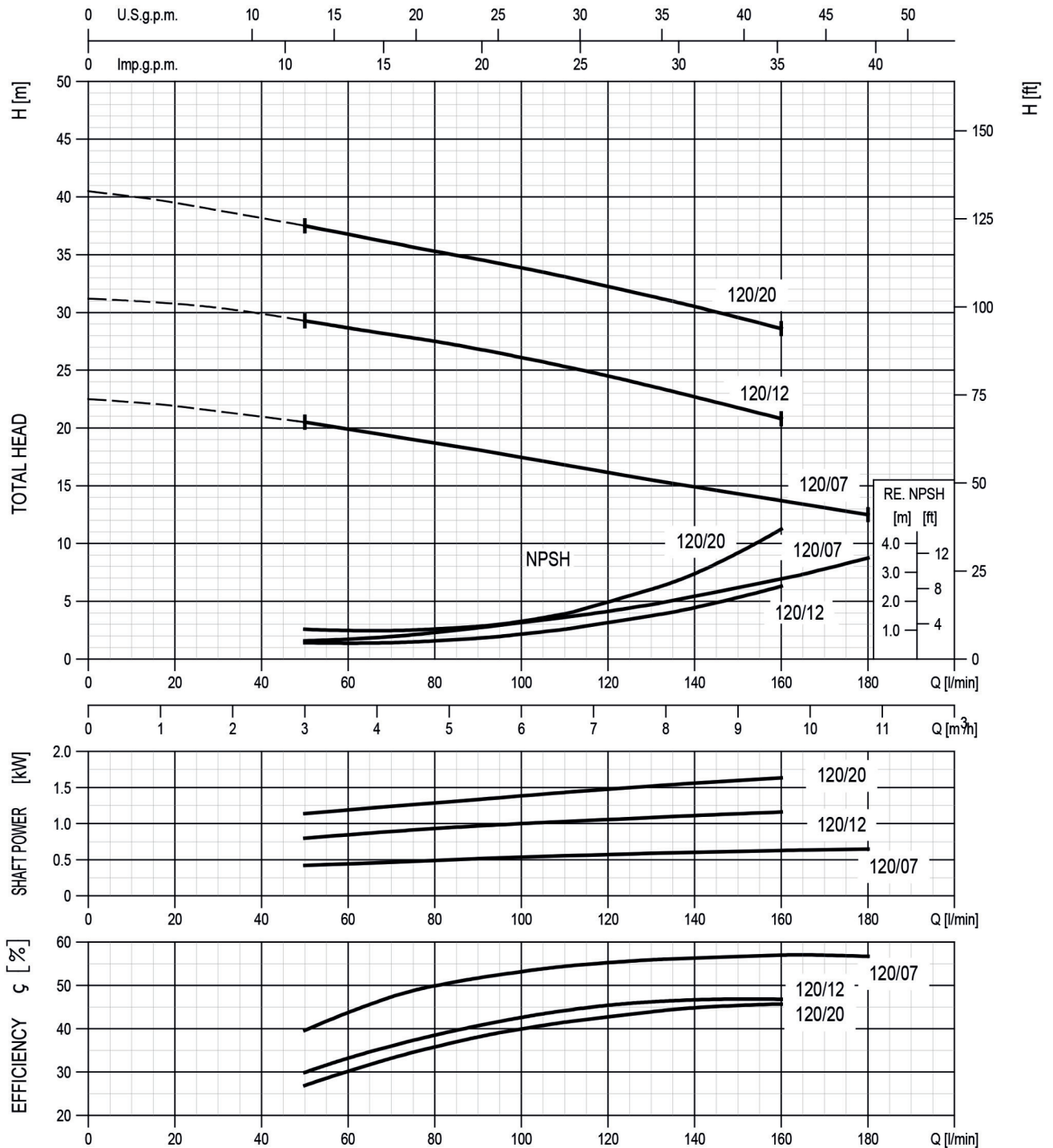

Rotation speed ≈ 2800 min⁻¹

CD 200/12 (0.90 kW) MEI > 0.50 - Impeller diameter = 132 mm
 CD 200/20 (1.50 kW) MEI > 0.60 - Impeller diameter = 157 mm
 CD 200/25 (1.80 kW) MEI > 0.40 - Impeller diameter = 176 mm

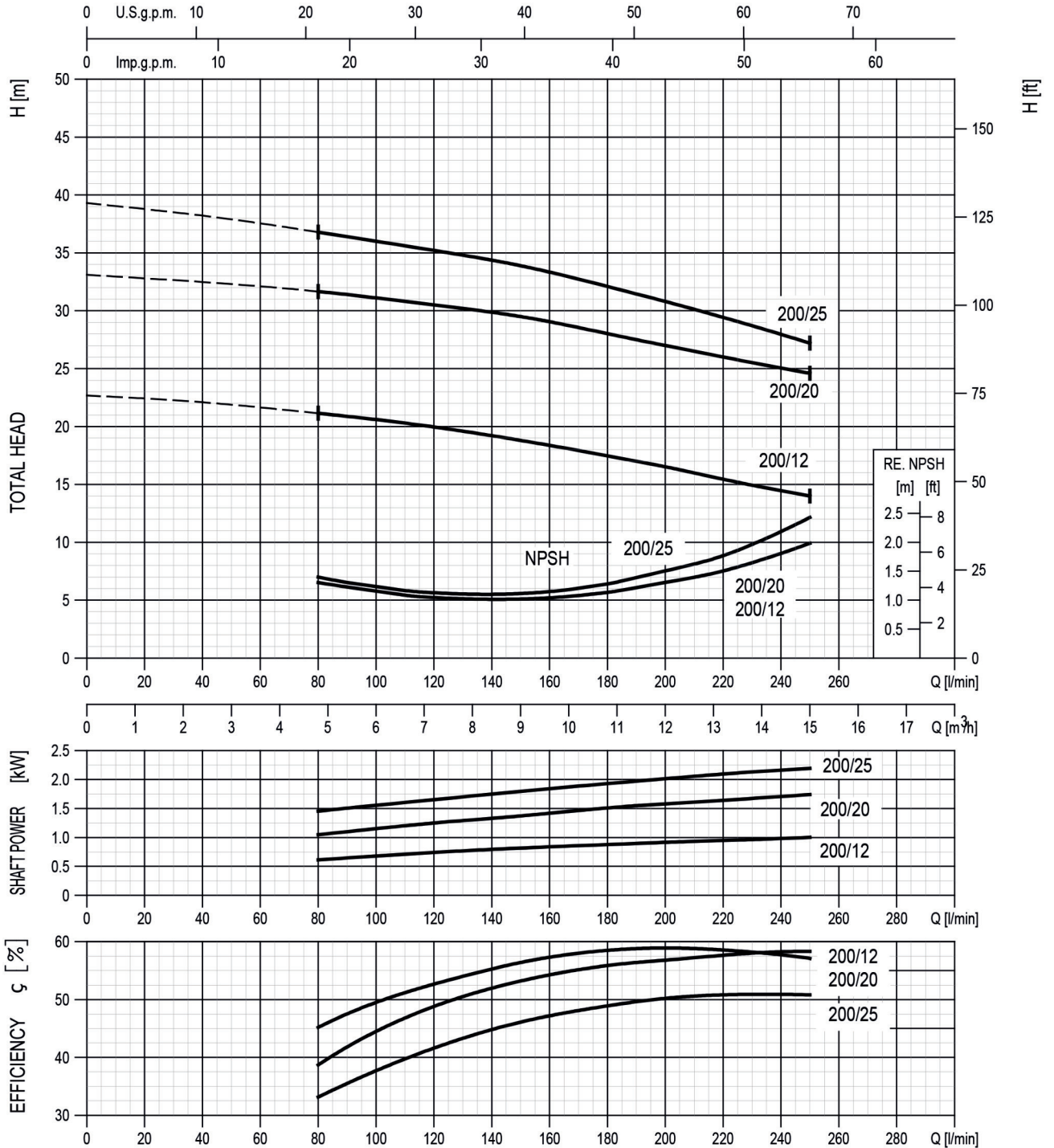

Rotation speed ≈ 2800 min⁻¹
 Test standard: ISO 9906:2012 – Grade 3B

SECTIONAL VIEW CD 70/05 - 70/07 - 90/10

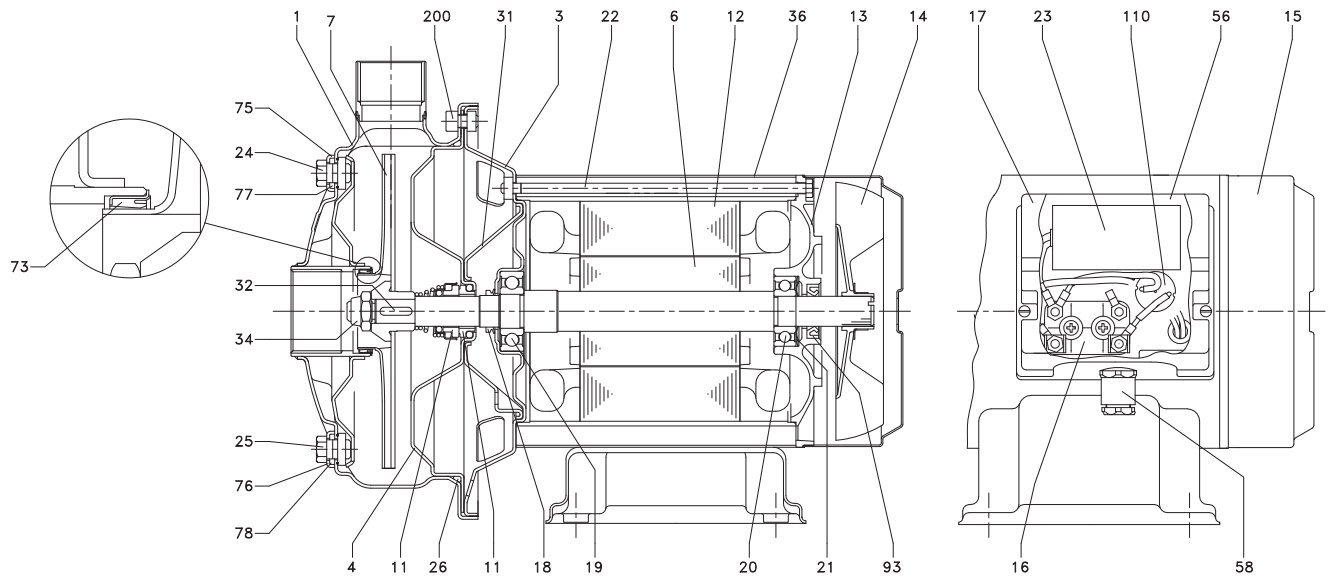

N°	PART NAME	MATERIAL	DIMENSION	STANDARD	Q.TY
1	Casing	AISI 304			1
3	Motor bracket	AISI 304			1
4	Casing cover	AISI 304			1
6	Shaft with rotor	AISI 303 (Wet extension)			1
7	Impeller	AISI 304			1
11	Mechanical seal [4]	Ceramic/Carbon/NBR			1
12	Motor frame with stator	-			1
13	Motor cover	Aluminium			1
14	Fan	PA			1
15	Fan cover	AISI 304			1
16	Terminal board	-			1
17	Terminal box cover	PA66 glass fibre reinforced class V-0			1
18	Splash ring	NBR			1
19	Pump side ball bearing	-			1
20	Fan side ball bearing	-			1
21	Adjusting ring	Steel C70			1
22	Tie rod	Fe 420 Galvanized			4
23	Capacitor [1]	-			1
24	Priming plug	AISI 304			1

N°	PART NAME	MATERIAL	DIMENSION	STANDARD	Q.TY
25	Drain plug	AISI 304			1
26	O-ring [2]	NBR			1
31	Thrust flange	AISI 304			1
32	Key	AISI 316	4x4x14	UNI 6604	1
34	Impeller nut	Stainless steel A2-70	M10X1,25	UNI 7474	1
36	Motor casing	AISI 304			1
56	Box gasket	NBR			1
58	Cable entry	-			1
73	Casing ring [3]	NBR			1
75	Washer	AISI 304			1
76	Washer	AISI 304			1
77	O-ring [2]	NBR			1
78	O-ring [2]	NBR			1
93	Lip seal	NBR			1
110	Protector [1]	-			1
200	Screw	Stainless steel A2-70	M6X12 M8X14	UNI 5931	8

[1] Only for single phase

[2] FPM for H-HS-HW-HSW
EPDM for E and Special Mechanical Seal

[3] FPM for CDH 70/05, CDHS 70/05, CDHW 70/05, CDHSW 70/05, CDH 70/07, CDHS 70/07, CDHW 70/07, CDHSW 70/07, CDH 90/10, CDHS 90/10, CDHW 90/10, CDHSW 90/10
NBR for CDE 70/05, 70/07, 90/10

[4] See **MECHANICAL SEAL** pages 303-304

SECTIONAL VIEW CD 70/12 - 120/07 - 120/20

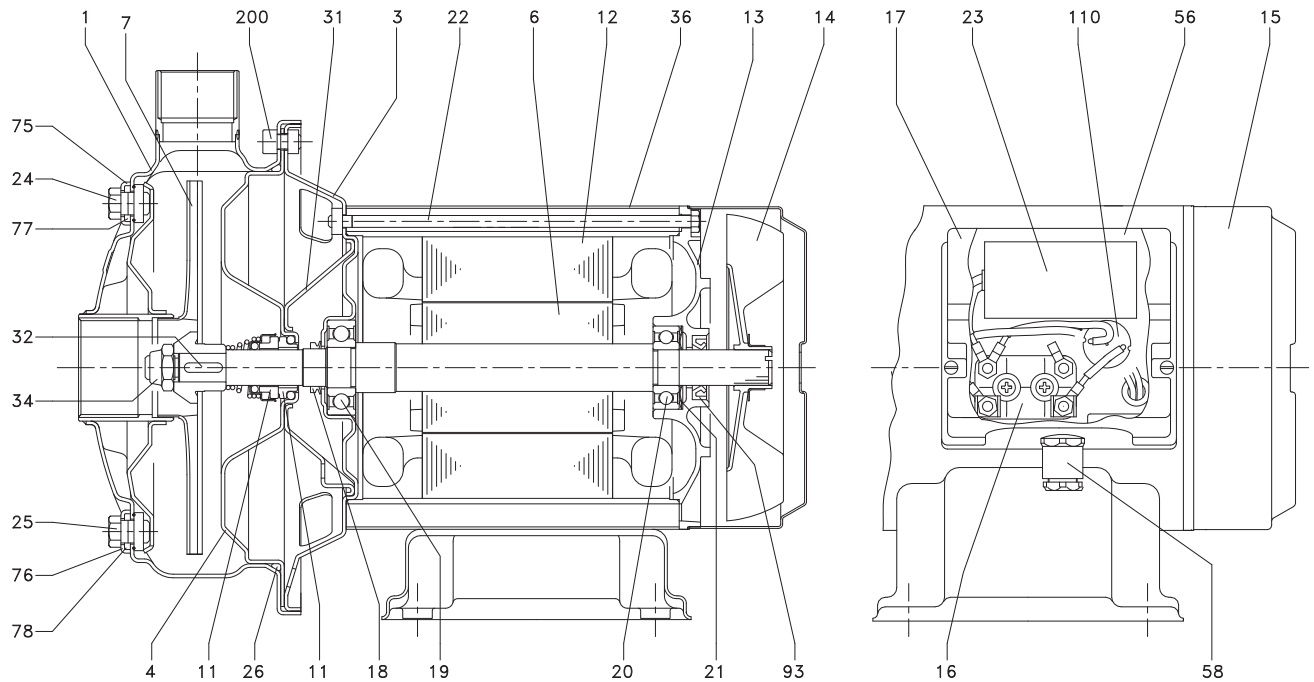

N°	PART NAME	MATERIAL	DIMENSION	STANDARD	Q.TY
1	Casing	AISI 304			1
3	Motor bracket	AISI 304			1
4	Casing cover	AISI 304			1
6	Shaft with rotor	AISI 303 (Wet extension)			1
7	Impeller	AISI 304			1
11	Mechanical seal [3]	Ceramic/Carbon/NBR			1
12	Motor frame with stator	-			1
13	Motor cover	Aluminium			1
14	Fan	PA			1
15	Fan cover	AISI 304			1
16	Terminal board	-			1
17	Terminal box cover	PA66 glass fibre reinforced class V-0			1
18	Splash ring	NBR			1
19	Pump side ball bearing	-			1
20	Fan side ball bearing	-			1
21	Adjusting ring	Steel C70			1
22	Tie rod	Fe 420 Galvanized			4
23	Capacitor [1]	-			1
24	Priming plug	AISI 304			1

N°	PART NAME	MATERIAL	DIMENSION	STANDARD	Q.TY
25	Drain plug	AISI 304			1
26	O-ring [2]	NBR			1
31	Thrust flange	AISI 304			1
32	Key	AISI 316	4x4x14	UNI 6604	1
34	Impeller nut	Stainless steel A2-70	M10X1,25	UNI 7474	1
36	Motor casing	AISI 304			1
56	Box gasket	NBR			1
58	Cable entry	-			1
73	Casing ring	-			1
75	Washer	AISI 304			1
76	Washer	AISI 304			1
77	O-ring [2]	NBR			1
78	O-ring [2]	NBR			1
93	Lip seal	NBR			1
110	Protector [1]	-			1
200	Screw	Stainless steel A2-70	M6X12	UNI 5931	8
			M8X14		

- [1] Only for single phase
 [2] FPM for H-HS-HW-HSW
 EPDM for E and Special Mechanical Seal
 [3] See **MECHANICAL SEAL** pages 303-304

SECTIONAL VIEW CD 120/12 - CD 200/12 - CD 200/20 - CD 200/25

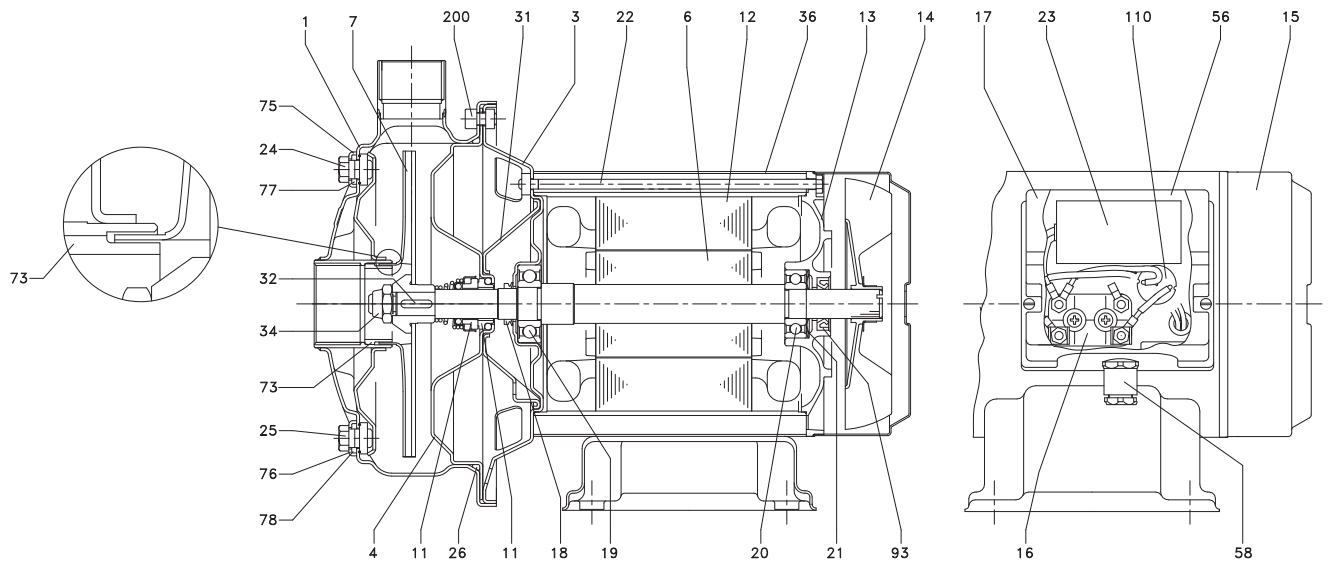

N°	PART NAME	MATERIAL	DIMENSION	STANDARD	Q.TY
1	Casing	AISI 304			1
3	Motor bracket	AISI 304			1
4	Casing cover	AISI 304			1
6	Shaft with rotor	AISI 303 (Wet extension)			1
7	Impeller	AISI 304			1
11	Mechanical seal [3]	Ceramic/Carbon/NBR			1
12	Motor frame with stator	-			1
13	Motor cover	Aluminium			1
14	Fan	PA			1
15	Fan cover	AISI 304			1
16	Terminal board	-			1
17	Terminal box cover	PA66 glass fibre reinforced class V-0			1
18	Splash ring	NBR			1
19	Pump side ball bearing	-			1
20	Fan side ball bearing	-			1
21	Adjusting ring	Steel C70			1
22	Tie rod	Fe 420 Galvanized			4
23	Capacitor [1]	-			1
24	Priming plug	AISI 304			1

N°	PART NAME	MATERIAL	DIMENSION	STANDARD	Q.TY
25	Drain plug	AISI 304			1
26	O-ring [2]	NBR			1
31	Thrust flange	AISI 304			1
32	Key	AISI 316	4x4x14	UNI 6604	1
34	Impeller nut	Stainless steel A2-70	M10X1,25	UNI 7474	1
36	Motor casing	AISI 304			1
56	Box gasket	NBR			1
58	Cable entry	-			1
73	Double ring	AISI 304			1
75	Washer	AISI 304			1
76	Washer	AISI 304			1
77	O-ring [2]	NBR			1
78	O-ring [2]	NBR			1
93	Lip seal	NBR			1
110	Protector [1]	-			1
200	Screw	Stainless steel A2-70	M6X12 M8X14	UNI 5931	8

- [1] Only for single phase
 [2] FPM for H-HS-HW-HSW
 EPDM for E and Special Mechanical Seal
 [3] See **MECHANICAL SEAL** pages 303-304

MECHANICAL SEAL

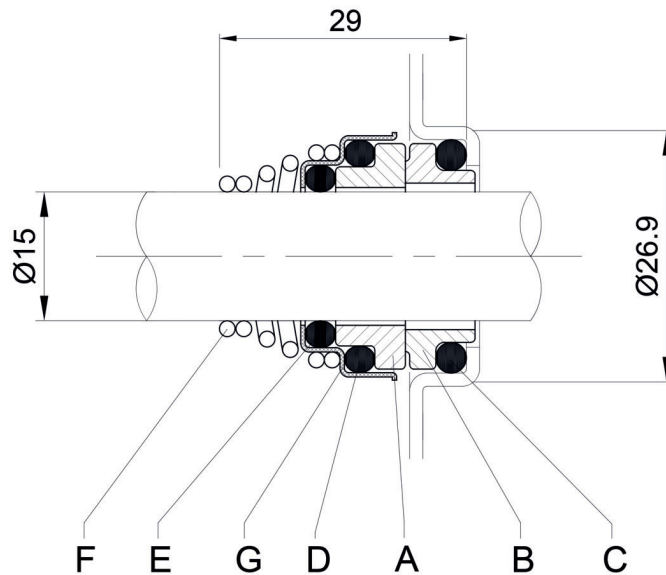

STANDARD
+
"L" version

REF	PART NAME	MATERIAL
A	Rotary seal ring	Ceramic
B	Stationary seal ring	Carbon graphite
C	O-Ring	NBR
D	O-Ring	NBR
E	O-Ring	NBR
F	Self-driving spring	AISI 316
G	Frame	AISI 304

REF	PART NAME	MATERIAL			
		H	HW	HSW	E
A	Rotary seal ring	Ceramic	Tungsten carbide	Silicon carbide	Ceramic
B	Stationary seal ring	Carbon graphite	Tungsten carbide	Tungsten carbide	Carbon graphite
C	O-Ring	FPM	FPM	FPM	EPDM
D	O-Ring	FPM	FPM	FPM	EPDM
E	O-Ring	FPM	FPM	FPM	EPDM
F	Self-driving spring	AISI 316	AISI 316	AISI 316	AISI 316
G	Frame	AISI 304	AISI 316	AISI 316	AISI 316

OPTIONAL

SPECIAL

REF	PART NAME	MATERIAL			
		Q1U3EGG	VAEGG	U3U3EGG	U3CEGG
A	Rotary seal ring	Silicon carbide	Ceramic	Tungsten carbide	Tungsten carbide
B	Stationary seal ring	Tungsten carbide	Metallised carbon	Tungsten carbide	special Carbon
C	O-Ring	EPDM	EPDM	EPDM	EPDM
D	O-Ring	EPDM	EPDM	EPDM	EPDM
E	O-Ring	EPDM	EPDM	EPDM	EPDM
F	Self-driving spring	AISI 316	AISI 316	AISI 316	AISI 316
G	Frame	AISI 316	AISI 316	AISI 316	AISI 316

MECHANICAL SEAL

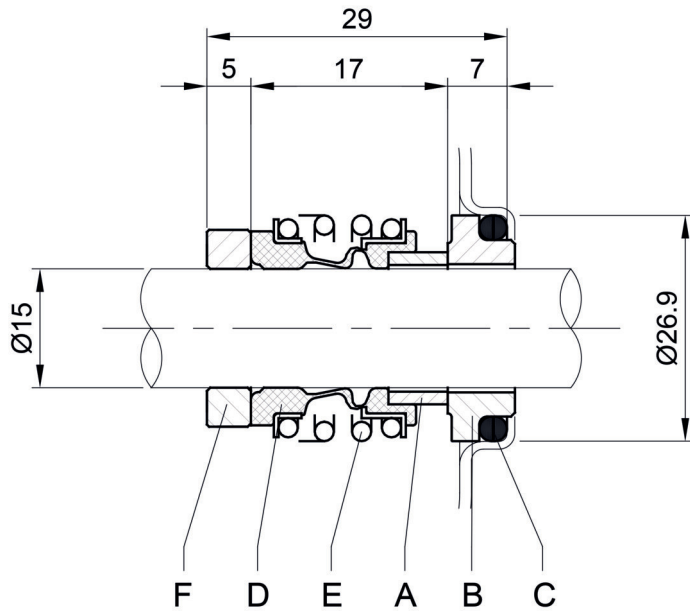

OPTIONAL

REF	PART NAME	MATERIAL HS
A	Rotary seal ring	Silicon carbide
B	Stationary seal ring	Silicon carbide
C	O-Ring	FPM
D	Bellows	FPM
E	Frame + Spring	AISI 316
F	Spacer ring	AISI 316

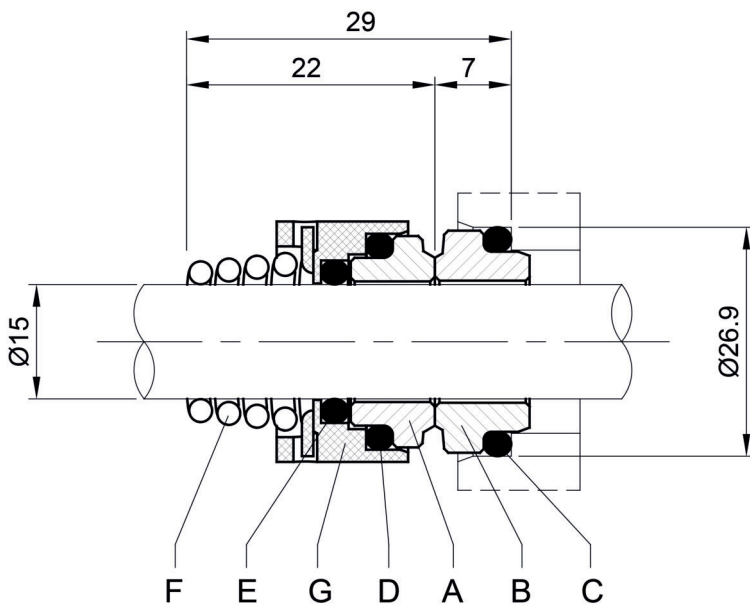

SPECIAL

REF	PART NAME	MATERIAL Q1AEGG
A	Rotary seal ring	Silicon carbide
B	Stationary seal ring	Metallised carbon
C	O-Ring	EPDM
D	O-Ring	EPDM
E	O-Ring	EPDM
F	Self-driving spring	AISI 316
G	Frame	AISI 316

BEARINGS

Pump type		Ball Bearing			
Single Phase	Three Phase	Pump side		Fan side	
		[1~]	[3~]	[1~]	[3~]
CDM 70/05	CD 70/05	6203 2RSH	6203 2DW C3	6202 2RSH	6202 2DW C3
CDM 70/07	CD 70/07	6203 2RSH	6203 2DW C3	6202 2RSH	6202 2DW C3
CDM 70/12	CD 70/12	6203 2RSH	6203-ZZ C3	6202 2RSH	6202-ZZ C3
CDM 90/10	CD 90/10	6203 2RSH	6203-ZZ C3	6202 2RSH	6202-ZZ C3
CDM 120/07	CD 120/07	6203 2RSH	6203 2DW C3	6202 2RSH	6202 2DW C3
CDM 120/12	CD 120/12	6203 2RSH	6203-ZZ C3	6202 2RSH	6202-ZZ C3
CDM 120/20	CD 120/20	6204 2RSH	6204-ZZ C3	6203 2RSH	6203-ZZ C3
CDM 200/12	CD 200/12	6203 2RSH	6203-ZZ C3	6202 2RSH	6202-ZZ C3
CDM 200/20	CD 200/20	6204 2RSH	6204-ZZ C3	6203 2RSH	6203-ZZ C3
-	CD 200/25	-	6204-ZZ C3	-	6203-ZZ C3

PUMP

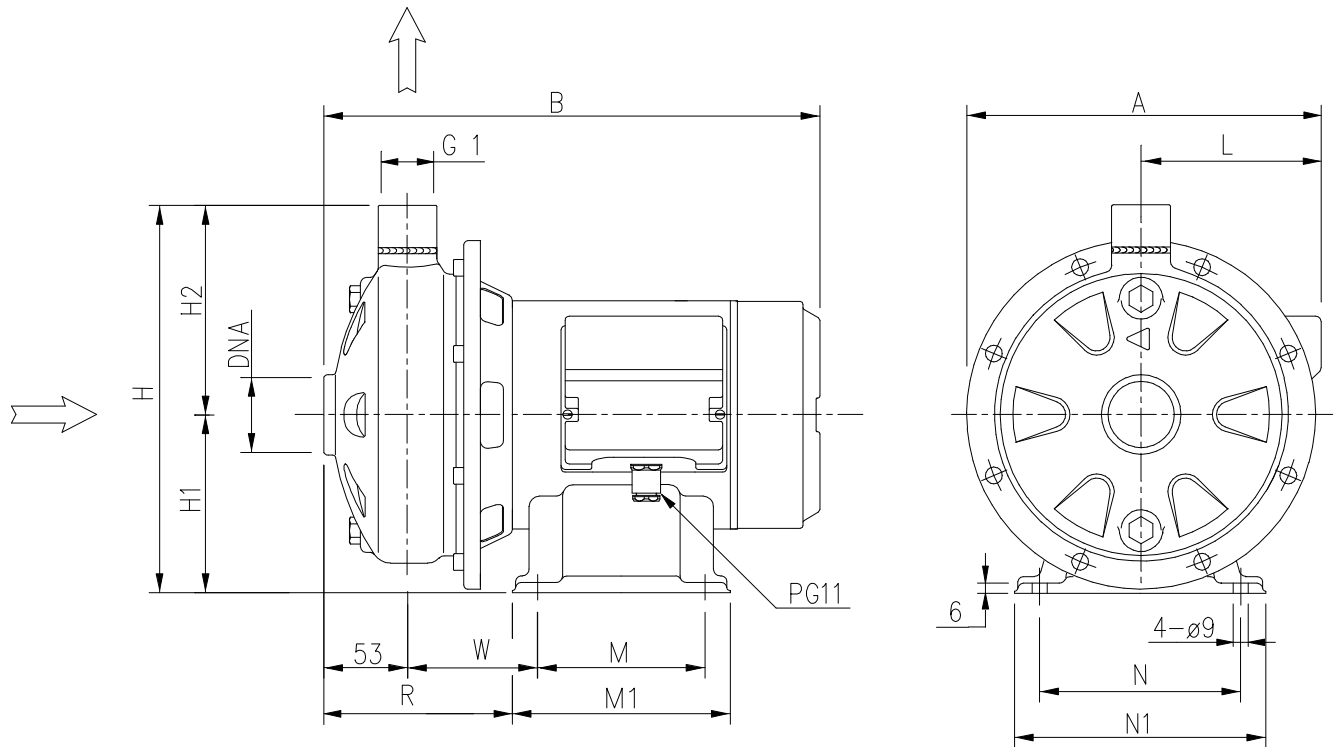

Pump type		Dimensions [mm]																	Weight [kgf]		
Single Phase	Three Phase	A		B		H	H1	H2	L		M		M1		N	N1	R	W	DNA	[1~]	[3~]
		[1~]	[3~]	[1~]	[3~]				[1~]	[3~]	[1~]	[3~]	[1~]	[3~]							
CDM 70/05	CD 70/05	209	208	298	298	229.5	106	123.5	105	104	100	100	130	130	120	150	115.5	77.5	G1"1/4	8.7	9.5
CDM 70/07	CD 70/07	209	208	298	328	229.5	106	123.5	105	104	100	100	130	130	120	150	115.5	77.5	G1"1/4	10	11.5
CDM 70/12	CD 70/12	208	208	328	338	229.5	106	123.5	104	104	100	100	130	130	120	150	135.5	97.5	G1"1/4	13.2	13.7
CDM 90/10	CD 90/10	209	208	328	328	229.5	106	123.5	105	104	100	100	130	130	120	150	130.5	92.5	G1"1/4	11.5	11.6
CDM 120/07	CD 120/07	209	208	298	328	229.5	106	123.5	105	104	100	100	130	130	120	150	115.5	77.5	G1"1/4	10	12
CDM 120/12	CD 120/12	208	208	328	338	229.5	106	123.5	104	104	100	100	130	130	120	150	135.5	97.5	G1"1/4	12.3	12.9
CDM 120/20	CD 120/20	232	232	356	376	250	118	132	116	116	120	120	150	150	140	170	133	95	G1"1/4	15.3	18.3
CDM 200/12	CD 200/12	208	208	328	338	229.5	106	123.5	104	104	100	100	130	130	120	150	135.5	97.5	G1"1/2	12	12.6
CDM 200/20	CD 200/20	213	213	356	376	229.5	106	123.5	109	109	120	120	150	150	140	170	133	95	G1"1/2	15.8	17.5
-	CD 200/25	-	232	-	376	250	118	132	-	116	-	120	-	150	140	170	138	100	G1"1/2	-	18.3

[1~] Single phase
[3~] Three phase

PACKING

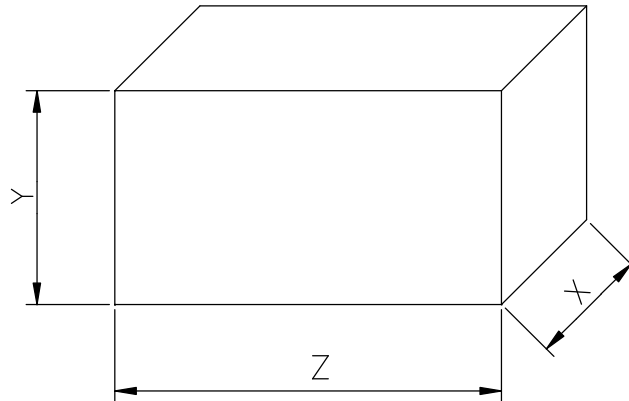

Pump type		Packing [mm]			Weight [kgf]	
Single Phase	Three Phase	X	Y	Z	[1~]	[3~]
CDM 70/05	CD 70/05	239	250	362	9.6	10.4
CDM 70/07	CD 70/07	239	250	362	10.8	12.3
CDM 70/12	CD 70/12	244	279	382	13.8	14.6
CDM 90/10	CD 90/10	239	250	362	12.2	12.4
CDM 120/07	CD 120/07	239	250	362	10.5	12.8
CDM 120/12	CD 120/12	239	250	362	13	13.7
CDM 120/20	CD 120/20	252	279	402	17.5	19.2
CDM 200/12	CD 200/12	239	250	362	12.8	13.4
CDM 200/20	CD 200/20	252	279	402	16.6	18.5
-	CD 200/25	252	279	402	-	19.3

[1~] Single phase

[3~] Three phase

MOTOR DATA

Pump type		Power		Efficiency		Capacitor		Efficiency (% load)			Input		Full load current			Locked rotor current		
Single Phase	Three Phase	[kW]	[HP]	Single Phase	Three Phase	Single Phase		Three phase			[kW]		[A]			[A]		
						[μF]	[V]	50%	75%	100%	Single Phase	Three Phase	Single Phase	Three Phase	Single Phase	Three Phase	Single Phase	Three Phase
CDM 70/05	CD 70/05	0.37	0.5	-	IE3	12.5	450	75.1	78.5	78.0	0.75	0.71	3.4	2.4	1.4	10.1	12.7	7.3
CDM 70/07	CD 70/07	0.55	0.75	-	IE3	16	450	80.2	82.8	82.9	1.10	0.91	5.0	3.0	1.7	16.1	20.5	11.8
CDM 70/12	CD 70/12	0.9	1.2	-	IE3	31.5	450	81.7	83.1	82.4	1.50	1.34	6.5	4.3	2.5	24.5	28.8	16.6
CDM 90/10	CD 90/10	0.75	1.0	-	IE3	20	450	80.9	82.3	82.1	1.20	1.05	5.6	3.3	1.9	22.7	19.7	11.4
CDM 120/07	CD 120/07	0.55	0.75	-	IE3	16	450	80.2	82.8	82.9	0.97	0.91	4.6	3.0	1.7	16.1	20.5	11.8
CDM 120/12	CD 120/12	0.9	1.2	-	IE3	31.5	450	81.7	83.1	82.4	1.60	1.34	6.9	4.3	2.5	25	28.8	16.6
CDM 120/20	CD 120/20	1.5	2.0	-	IE3	40	450	84.2	86.8	86.9	2.10	2.01	9.3	7.1	4.1	43	66.6	38.4
CDM 200/12	CD 200/12	0.9	1.2	-	IE3	31.5	450	81.7	83.1	82.4	1.40	1.34	6.3	4.3	2.5	25	28.8	16.6
CDM 200/20	CD 200/20	1.5	2.0	-	IE3	40	450	84.2	86.8	86.9	2.30	2.01	10.2	7.1	4.1	43	66.6	38.4
-	CD 200/25	1.85	2.5	-	IE3	-	-	86.2	87.0	86.0	-	2.55	-	8.2	4.7	-	66.6	38.43

NOISE DATA

Pump type		Power		L _{pA} - dB(A) *
Single Phase	Three Phase	[kW]	[HP]	
CDM 70/05	CD 70/05	0.37	0.5	<70
CDM 70/07	CD 70/07	0.55	0.75	
CDM 70/12	CD 70/12	0.9	1.2	
CDM 90/10	CD 90/10	0.75	1.0	
CDM 120/07	CD 120/07	0.55	0.75	
CDM 120/12	CD 120/12	0.9	1.2	
CDM 120/20	CD 120/20	1.5	2.0	
CDM 200/12	CD 200/12	0.9	1.2	
CDM 200/20	CD 200/20	1.5	2.0	
-	CD 200/25	1.85	2.5	

* Mean value of several measures at 1m distance around the pump.
Tolerance ± 2.5 dB.