

## USER'S GUIDE

### KD SERIE



## Index.

	Pag.
1.- Introduction _____	3
1.1.- Previous considerations.	
2.- Setting up _____	4
2.1.- Setting up description.	
2.2.- Dimensions.	
2.3.- Other specifications.	
3.- Pump operation _____	8
3.1.- First operation.	
3.2.- Lubrication.	
3.3.- Maintenance.	
3.4.- Troubles and solutions.	
3.5.- Basic repairs.	
4.- Spare parts _____	17
5.- Warranty _____	22

## 1.- INTRODUCTION.

### 1.1. Previous considerations.



*Safety symbol. This symbol on the present document states that the point described thereafter involves very important information regarding the safety of the vacuum pump operation.*



*The vacuum pump is one component of the vacuum unit (tanker). It is totally necessary to read the operation booklet provided by the tank manufacturer before operating with the pump and the tanker.*



*The non-observance of the advised safety indications may cause injury to the pump operator.*



*Take special care of the distance to be kept to any mobile part of the vacuum pump. Read carefully all the information related to this point on the tank manufacturer booklet.*



*Never use the vacuum pump in inflammable atmospheres in order to prevent the risk of explosion due to the working temperature of the vacuum pump.*

## 2.- SETTING UP.



*Always be careful by hanging the vacuum pump. Use the hole situated at the top of the pump body to lift the pump, keeping always the safety distance to avoid injuries due to a sudden fall down of the pump.*

### 2.1. Setting up description.

Enclosed is one basic setting-up schema of the vacuum pump on the vacuum tanker. End montage may vary from this basic description, which only shows the non-dispensable parts of the system.

Some accessories of the pump are packed in one cartoon box to make easier the process of palletising and transporting the vacuum pumps.



*Never manipulate the pump when the cardan shaft or driven system of the vacuum pump is connected.*

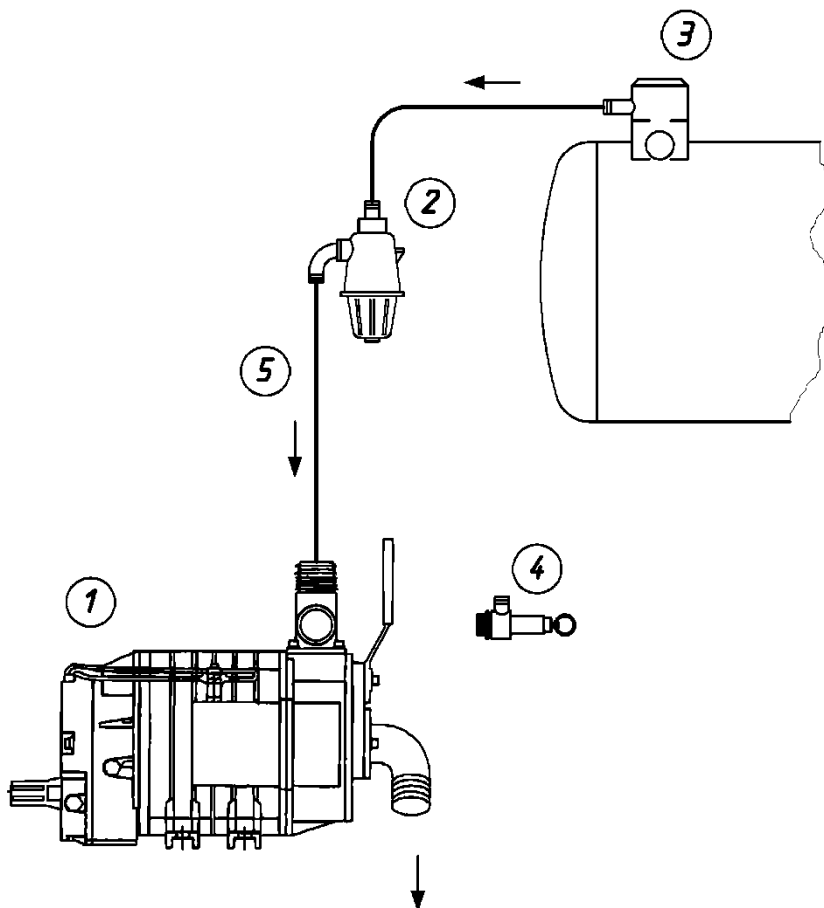

- 1.- Vacuum Pump.
- 2.- Siphon valve.
- 3.- Overflow valve.
- 4.- Safety valve.
- 5.- Vacuum pipe.

The overflow valve (3) guarantees that, when filling up tank, the liquid cannot get into the vacuum pump. Anyway, a setting up of the siphon valve (2) is highly recommended in order to be sure that no liquid comes into the vacuum pump.

Up from KD-8000 vacuum pump it is recommended to use a Ø 80 mm pipe (5). To install a narrower pipe as the recommended one can follow to an overheating of the air sucked and may damage the pump.

In order to prevent the over pressure and the rupture risk of the tanker it is necessary to install a pressure safety valve (4) on system. It is strongly recommended to install at least one of these valves on the vacuum pump.



***Always be sure that the pressure safety valve is in good working conditions, especially when installing a new pump in an old tanker.***

Depending on the vacuum installation a vacuum relief valve (4 too) can be mounted on the vacuum pump to limit the maximal vacuum level. The fact of decreasing the vacuum level increases the operation time of the pump. All these variables depend on the working conditions of the vacuum tanker.

It is the decision of the tank manufacturer to choose the dimension of the pump the same way as the other accessories of the tanker.



***No manipulations of the vacuum pump are permitted without the supervision of the tank manufacturer or his authorized technical service.***

## 2.2.- Dimensions.

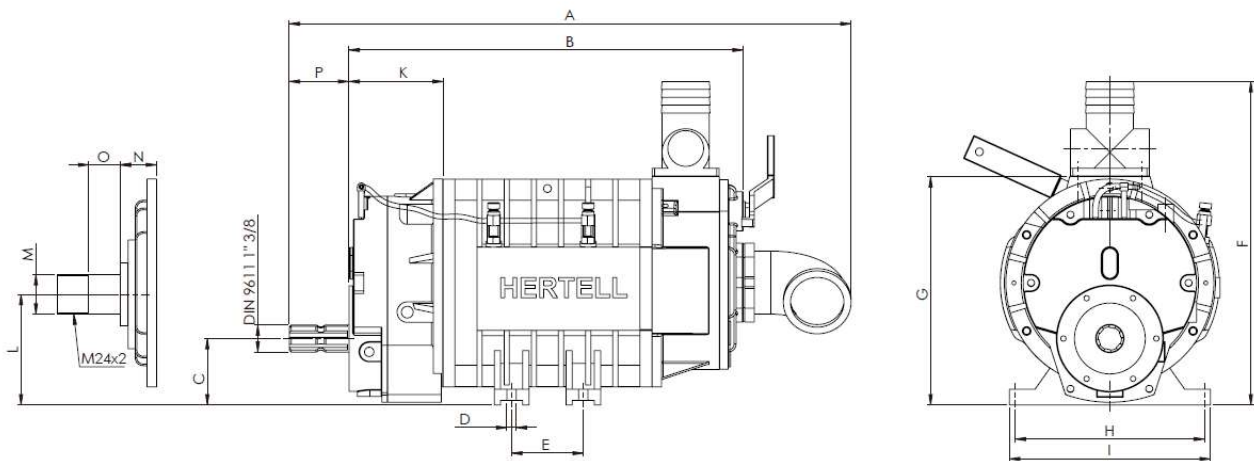

Mod.	A	B	C	D	E	F	G	H	I	K	L	M	N	O	Q	Weight Kg
<b>KD-3.000</b>	570	370	80	16	88	410	290	240	260	115	169.5	28	31	30	79	64
<b>KD-4.000</b>	620	420	80	16	88	410	290	240	260	115	169.5	28	31	30	79	70
<b>KD-5.000</b>	675	475	80	16	88	410	290	240	260	115	169.5	28	31	30	79	75
<b>KD-6.500</b>	710	490	95	20	140	460	340	280	310	130	200	32	35	34	79	106
<b>KD-8.000</b>	770	550	95	20	140	460	340	280	310	130	200	32	35	34	79	117
<b>KD-10.000</b>	830	610	95	20	140	460	340	280	310	130	200	32	35	34	79	130
<b>KD-12.000</b>	895	675	95	20	140	460	340	280	310	130	200	32	35	34	79	143

### 2.3. Other specifications.

<b>Mod.</b>	<b>KD-3</b>	<b>KD-4</b>	<b>KD-5</b>	<b>KD-6.5</b>	<b>KD-8</b>	<b>KD-10</b>	<b>KD-12</b>
Rpm.Max.	540	540	540	540 1.000	540 1.000	540 1.000	540 1.000
Max. vacuum (%)	90	90	90	90	90	90	90
Max. pressure (bar)	1,5	1,5	1,5	1,5	1,5	1,5	1,5
Weight (kG)	64	70	75	106	117	130	143
Noise level (dB)	85	86	86	87	87	87	88
Power consumption (kW)	8	10	12	15	18	22	25

Power consumption and noise level at maximum pressure

### 3.- PUMP OPERATION.

(Picture 1)

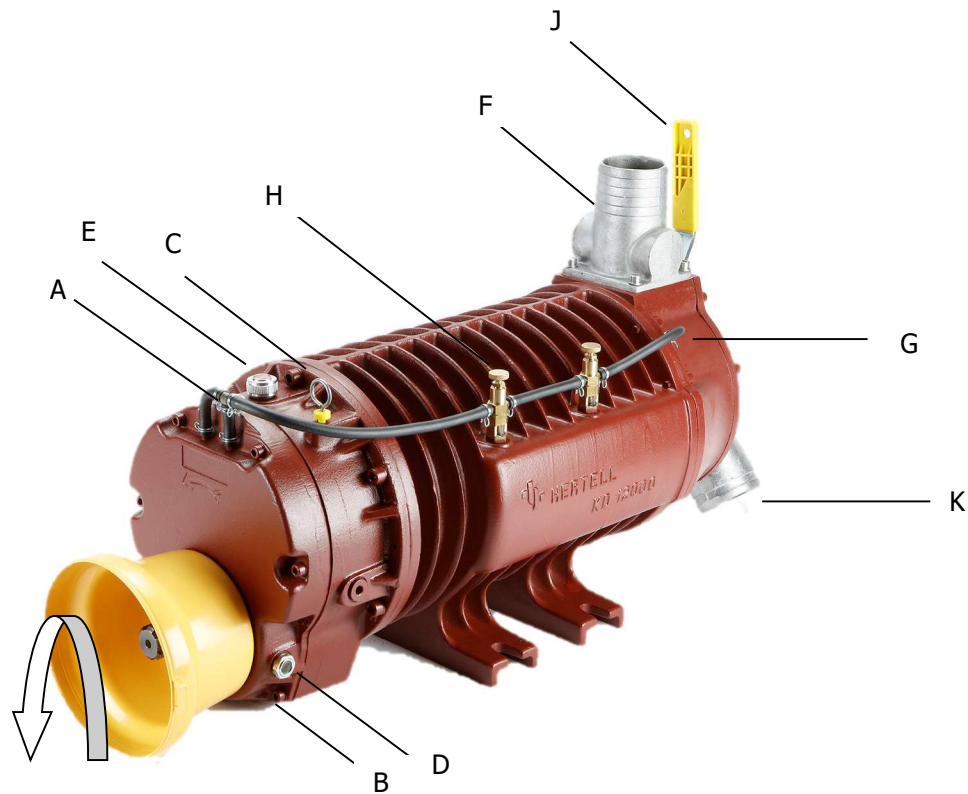

#### 3.1.- First operation



***Maximal angle between cardan shaft axe and pump shaft should not exceed 15° for 540 rpm pumps and 7° for 1000 rpm pumps.***



***Never manipulate the pump when the cardan shaft or driven system is connected to the vacuum pump.***

KD Pumps always run counter-clockwise sense, as stated at the front cover. Be sure that the driven system (cardan shaft or similar) turns on the right sense. The pump coupling F has to be connected and secured to the vacuum pipe. For the first operation, just prepare the tanker for vacuum operation, put the handle (J) on “V” vacuum position and let the pump run at the estimated turning speed. Drop feeders (H) will be start lubricating after some seconds. Check that the minimal distance between the outlet K and any object in risk of being sucked into the pump is at least 100 cm.





*The vacuum / pressure operations are regulated by handle J. The vacuum tanker has to guarantee that the manipulation of this is possible without any risk for the operator.*



*The maximal working time under maximal vacuum level (with no vacuum relief valve on the system) must not exceed 8 minutes or 90° temperature. The non-observance of these indications can damage seriously the pump.*



*To stop operating with the pump, first stop the cardan shaft before manipulating the pump.*

Each KD vacuum pump has one flange at the front cover to assembly of one hydraulic drive.

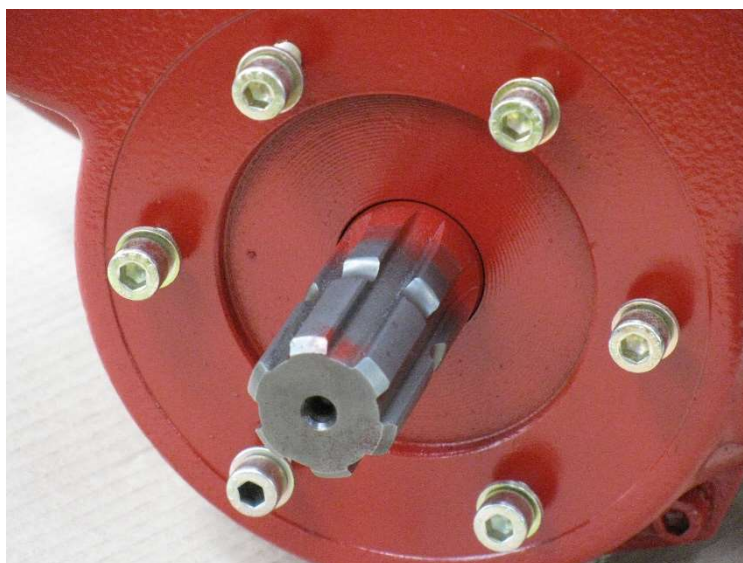

In case of one hydraulic drive, check that the oil flow and pressure are the ones required to drive the pump at the correct rpm turning speed of the vacuum pump, not exceeding that speed in any case.



### 3.2.- Lubrication.

#### 3.2.1.- Vane's lubrication.

When the pump is operating the vanes have to be lubricated. The vanes lubrication oil is filled up through plug E and controlled with oil lever indicator C (see picture 1). This level has to be controlled each day to be sure that pump is not running dry. Oil tank capacity allows 4 hours of working time.

Each vacuum pump has been tested and therefore the drop feeders (H) have been regulated before leaving the Works. One normal lubrication flow is between 15 and 20 drop per minute. Should the drop feeders need to be adjusted, then release the set screw M and adjust turning the nipple N (Picture 2). If the nipple is turned in clockwise sense, the oil flow decreases, and it increases with the opposite operation. After adjusting, tighten set screw M again.

(Picture 2)

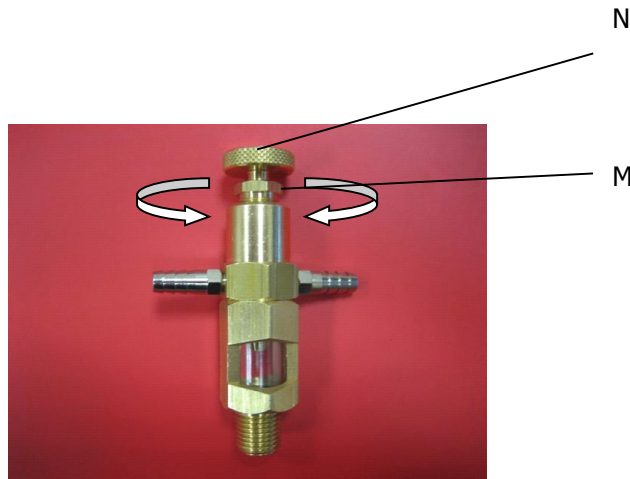

***Viscosity of the vanes lubrication oil: ISO VG - 68***

#### 3.2.2.-Gearbox lubrication.

The gearbox is filled to its maximal level (sight glass D) when pump is delivered. Never fill up over this maximum level. To fill up the gearbox oil, use plug A, and to empty use plug B. Gearbox oil has to be exchanged after 500 operation or at least once a year.



***Viscosity of the gearbox oil: ISO VG - 220***

### 3.3.-Maintenance.

The rear bearing has to be lubricated at least once a month through oilier G. Use a normal grease till the gap from bearing to the oilier is filled up. (KD-3000/5000).

The interior of the pump must be cleaned each time when any liquid of the tanker comes into the vacuum pump or, at least, once a year. It is highly recommended to do that when the pump is going to stay for a long time without usage. For this operation, release the vacuum pipe on coupling F, put the handle J in vacuum position, drive the pump at low speed and give some detergent through the coupling F.

The vanes have to be controlled after 650 hours of effective working time and have to be changed if the waste comes up to 10% of the original dimension:

<b>KD-3000</b>	(160 x 57 x 7,5) - 4 Un.
<b>KD-4000</b>	(210 x 57 x 7,5) - 4 Un.
<b>KD-5000</b>	(265 x 57 x 7,5) - 4 Un.
<b>KD-6500</b>	(240 x 64 x 7,5) - 6 Un.
<b>KD-8000</b>	(300 x 64 x 7,5) - 6 Un.
<b>KD-10000</b>	(360 x 64 x 7,5) - 6 Un.
<b>KD-12000</b>	(425 x 64 x 7,5) - 6 Un.

#### CHANGE :

1.- Unscrew the distributor.

2.- Take apart the distributor. Use the two extraction holes.

3.- Exchange the vanes.

4.- Before setting up, exchange the gasket.

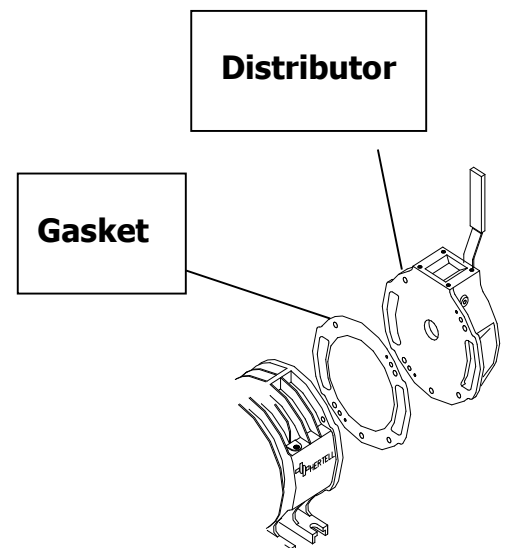

### 3.4.- Troubles and solutions.



*The pump is one part of the vacuum tanker. So, check that all the rest of the vacuum circuit is in a good condition before checking the pump. It is advised to take apart the vacuum pipe and make turn the pump to check if the pump is transferring air before start manipulating the interior of the pump. Always read the tank manufacturer instructions beforehand.*

TROUBLE	LIKELY ORIGIN	SOLUTION
Pumps is not turning	One vane is out.	Take apart the distributor and place the vanes.
	One object from the exterior has got into the pump.	Take apart and get out the object.
No vacuum or pressure	Non-correct turning sense.	Turn in correct sense.
	Low turning speed.	Turn at right speed.
	Pump body is damaged / wavy.	Change the pump body.
	Conic distributor is not in right position.	Place in right position.
No lubrication	Air aspiration on the lubrication pies.	Check pipes and nipples.
	Oil pump is broken.	Take apart oil tubes and check turning the shaft even by hand. I necessary, change the oil pump.
No retention of pressure	Retention flap is damaged	Change retention flap.

### 3.4.- Repairing description.

Enclosed advised repairing description for the most usual maintenance operation.

## **BASIC REPARIS & MAINTENANCE. KD VACUUM PUMP.**

*(See diagram on page 16)*

### **1. Vanes change (N.44).**

- 1.1 Take apart distributor N.41. Use the two extraction holes.
- 1.2 Exchange the vanes N.44.
- 1.3 Put a new gasket N.42.
- 1.4 Set up the distributor N.41.

---

### **2. Flap change (N.40) / Conic distributor change (N.22).**

Flap change (N.40).

- 2.1.1 Unscrew the cover N.29.
- 2.1.2 Unscrew the screw N.31. Exchange Flap. Put the screw N.31.
- 2.1.3 Change the Gasket N.30.
- 2.1.4 Set up the cover N.29.

---

2.2 Conic distributor change (N.22).

- 2.2.1 The same as 2.1.1.
  - 2.2.2 Unscrew the handle N.28.
  - 2.2.3 Take apart the conic distributor N.22 and exchange.
  - 2.2.4 The same as 2.1.3 to 2.1.4.
-

### **3. Seal change (N.5) / Gears change (N.8 - N .56) / Oil pump change (N.48-N.49-N.50-N.51).**

Seal change (N.5).

- 3.1.1. Empty the gearbox oil (Screw N.4 at cover N.54).
  - 3.1.2 Empty the lubrication oil (Screw N.4 at Gearbox N.47)
  - 3.1.3 Take apart the Guard N.59.
  - 3.1.4 Take apart the lubrication tube N.12.
  - 3.1.5 Unscrew the cover N.54. The gear N.8 will come together.
  - 3.1.6 Take apart bearing N.7 and / or seal N.5 and exchange.
  - 3.1.7 Change the gasket N.53.
  - 3.1.8 Set up the cover N.54. Take care while connecting the rotor and the oil pump axe. In order to prevent further damages, place both at vertical position.
  - 3.1.9 Fill up the gearbox and the lubrication oil tanks.
  - 3.1.10 Set up the oil lubrication tube.
  - 3.1.11 Set up the Guard N.59.
- 

3.2 Gears change (N.8 – N.56).

- 3.2.1 The same as 3.1.1 to 3.1.5.
  - 3.2.2 Unscrew the set screw N.52.
  - 3.2.3 Extract the gear N.56 and exchange.
  - 3.2.4 Screw the set screw N.52.
  - 3.2.5 The same as 3.1.7 to 3.1.11.
- 

3.3 Oil pump change (N.48 – N.49 – N-50 – N.51)

- 3.3.1 The same as 3.1.1 till 3.1.5.
- 3.3.2 Unscrew the cover N.48 and extract and change gears N.50 and N.51.
- 3.3.3 Exchange the gasket N.49.
- 3.3.4 Set up the cover N.48.
- 3.3.5 The same as 3.1.7 to 3.1.11.

#### **4. Rotor - Body change (N.45 – N.43) / Rotor bearing - Seal change(N.35 – N.36).**

##### 4.1 Rotor - Body change (N.44 – N.43).

- 4.1.1 The same as 1.1
  - 4.1.2 The same as 3.2.1 to 3.2.3.
  - 4.1.3 Take apart the oil tube N.12 and unscrew the drop feeders N.15.
  - 4.1.4 Unscrew the Gearbox N.47.
  - 4.1.5 Take apart the rotor N.45 and the body N.43, exchange and set up new ones. It is necessary to change vanes N.44. Set up drop feeders N.15.
  - 4.1.6 Change the gasket N.46 and set up the gearbox N.47.
  - 4.1.7 Set up the gear N.56.
  - 4.1.8 The same as 3.2.4. to 3.2.5.
  - 4.1.9 The same as 1.3 to 1.4.
- 

##### 4.2 Rotor bearing / seals exchange (N.35 – N.36).

- 4.2.1 The same as 4.1.1 to 4.1.4.
  - 4.2.2 Extract the bearing N.35 and the seal N.36 and exchange for new ones.
  - 4.2.3 Take apart the cover N.34.
  - 4.2.4 The same as 4.2.2. (Rear ones).
  - 4.2.5 The same as 4.1.5 to 4.1.9.
-



## 4.- Spare parts

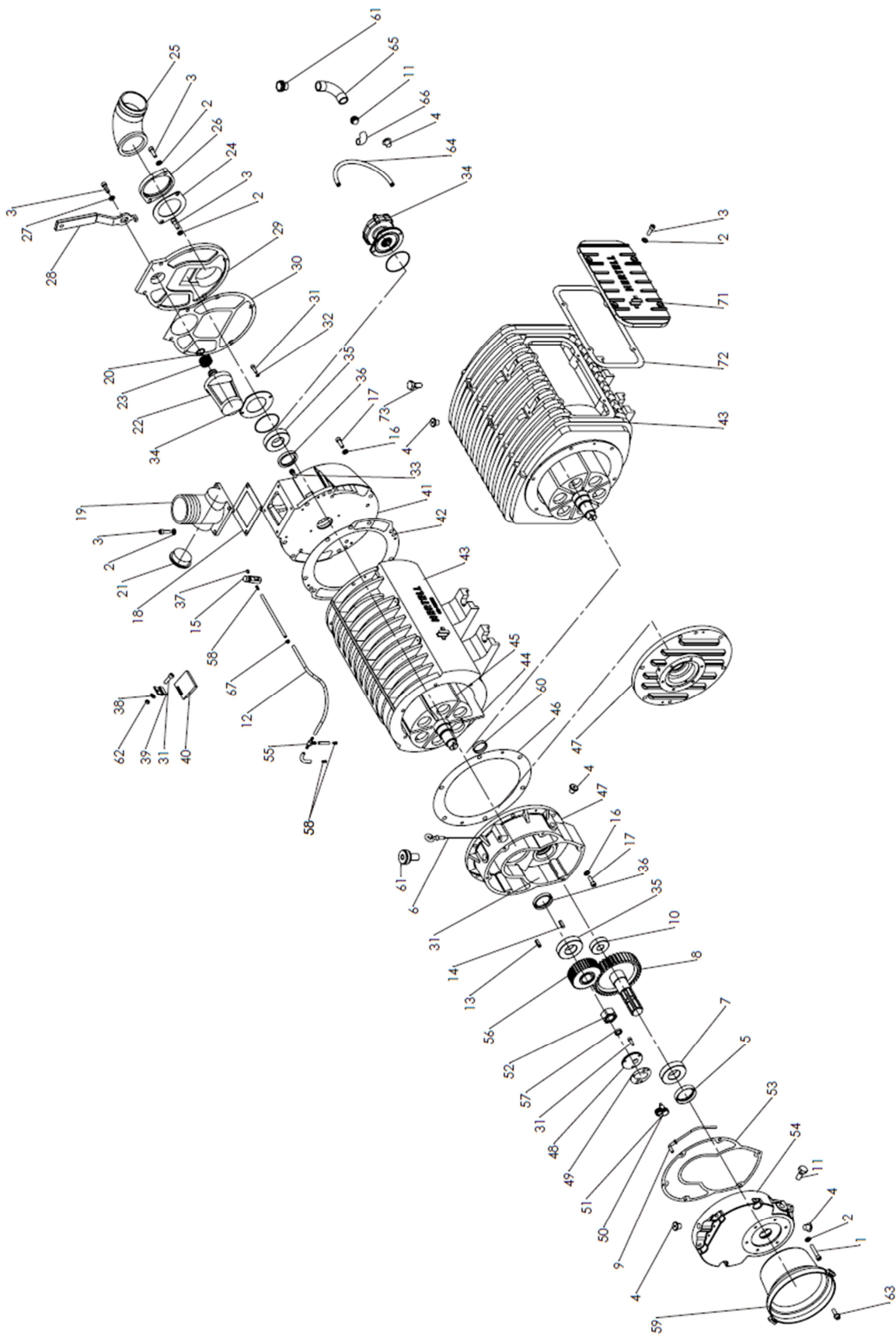

Reference	Denomination
01KD050001	N. 1. Screw for KD-3000/5000
01KD140001	N. 1. Screw for KD-6500/14000
01KD140002	N. 2. Washer for KD-3000/14000
01KD140003	N. 3. Screw for KD-3000/14000
01KD140004	N. 4. Plug for KD-3000/14000
01KD140005	N. 5. Seal for KD-3000/14000 35x55x10
01KD140006	N. 6. Oil level indicator KD-3000/14000
01KD050007	N. 7. Bearing for KD-3000/5000 6207
01KD140007	N. 7. Bearing for KD-6500/14000 6307
01KD050008	N. 8. Attack gear 49 teeth KD-3000/5000
01KD140008	N. 8. Attack gear 55 teeth KD-6500/14000
01KD141008	N. 8. Attack gear 1000 rpm KD-6500/14000
01KD140009	N. 9. Nipple 90 for KD-3000/14000
01KD140010	N.10. Bearing for KD-3000/14000 6304
01KD140011	N.11. Oil sight glass KD-3000/14000
01KD030012	N.12. Oil tube for KD- 3000
01KD040012	N.12. Oil tube for KD- 4000
01KD050012	N.12. Oil tube for KD- 5000
01KD060012	N.12. Oil tube for KD- 6500
01KD080012	N.12. Oil tube for KD- 8000
01KD100012	N.12. Oil tube for KD-10000
01KD120012	N.12. Oil tube for KD-12000
01KD140012	N.12. Oil tube for KD-14000
01KD140013	N.13. Elastic pin for KD-3000/14000
01KD050014	N.14. Key for KD-3000/5000
01KD140014	N.14. Key for KD-6500/14000
01KD140015	N.15. Drop feeder for KD-3000/14000
01KD140016	N.16. Washer for KD-3000/14000
01KD140017	N.17. Screw for KD-3000/14000
01KD050018	N.18. Gasket for KD-3000/5000
01KD140018	N.18. Gasket for KD-6500/14000
01KD050019	N.19. Outlet Ø 60 KD-3000/5000
01KD060019	N.19. Outlet Ø 60 KD-6500
01KD140019	N.19. Outlet Ø 80 KD-6500/14000
01KD141019	N.19. Outlet Ø 100 KD-14000
01KD052019	N.19. Double outlet Ø 60 KD-3000/5000
01KD062019	N.19. Double outlet Ø 60 KD-6500
01KD142019	N.19. Double outlet Ø 80 KD-6500/14000

01KD140020	N.20. O-Ring for KD-3000/14000
01KD140021	N.21. Plug for KD-3000/14000
01KD050022	N.22. Conic distributor for KD-3000/5000
01KD140022	N.22. Conic distributor for KD-6500/14000
01KD140023	N.23. Spring for KD-3000/14000
01KD140024	N.24. Outlet gasket KD-3000/14000
01KD140025	N.25. Outlet for KD-3000/14000
01KD140026	N.26. Flange for KD-3000/14000
01KD140027	N.27. Washer for KD-3000/14000
01KD140028	N.28. Handle for KD-3000/14000
01KD050029	N.29. Distributor cover KD- 3000/5000
01KD120029	N.29. Distributor cover KD- 6500/12000
01KD140029	N.29. Distributor cover KD-14000
01KD050030	N.30. Gasket for KD-3000/5000
01KD140030	N.30. Gasket for KD-6500/14000
01KD140031	N.31. Screw for KD-3000/14000
01KD140032	N.32. Washer for KD-3000/14000
01KD140033	N.33. Lubrication nipple for KD-3000/14000
01KD050034	N.34. Bearing cover for KD- 3000/5000
01KD140034	N.34. Bearing cover for KD- 6500/14000
01KD141034	N.34. Water pump for KD-14000
01KD050035	N.35. Bearing for KD-3000/5000 6207
01KD140035	N.35. Bearing for KD-6500/14000 6208
01KD050036	N.36. Seal for KD-3000/5000 40x55x8
01KD140036	N.36. Seal for KD-6500/14000 45x60x12
01KD140037	N.37. Plug M6 for KD-3000/14000
01KD140038	N.38. Copper washer KD-3000/14000
01KD140039	N.39. Hinge for KD-3000/14000
01KD050040	N.40. Plug forKD-3000/5000
01KD140040	N.40. Plug for KD-6500/14000
01KD050041	N.41. Distributor for KD- 3000/5000
01KD140041	N.41. Distributor for KD- 6500/14000
01KD050042	N.42. Gasket for KD-3000/5000
01KD140042	N.42. Gasket for KD-6500/14000
01KD030043	N.43. Body for KD- 3000
01KD040043	N.43. Body for KD- 4000
01KD050043	N.43. Body for KD- 5000
01KD060043	N.43. Body for KD- 6500
01KD080043	N.43. Body for KD- 8000
01KD100043	N.43. Body for KD-10000

01KD120043	N.43. Body for KD-12000
01KD140043	N.43. Body for KD-14000
01KD030044	N.44. Vane for KD- 3000 (160x57x7,5) 4
01KD040044	N.44. Vane for KD- 4000 (210x57x7,5) 4
01KD050044	N.44. Vane for KD- 5000 (265x57x7,5) 4
01KD060044	N.44. Vane for KD- 6500 (240x64x7,5) 6
01KD080044	N.44. Vane for KD- 8000 (300x64x7,5) 6
01KD100044	N.44. Vane for KD-10000 (360x64x7,5) 6
01KD140044	N.44. Vane for KD-12/14000 (425x64x7,5) 6
01KD030045	N.45. Rotor for KD- 3000
01KD040045	N.45. Rotor for KD- 4000
01KD050045	N.45. Rotor for KD- 5000
01KD060045	N.45. Rotor for KD- 6500
01KD080045	N.45. Rotor for KD- 8000
01KD100045	N.45. Rotor for KD-10000
01KD120045	N.45. Rotor for KD-12000
01KD140045	N.45. Rotor for KD-14000
01KD050046	N.46. Gasket for KD-3000/5000
01KD140046	N.46. Gasket for KD-6500/14000
01KD050047	N.47. Gearbox for KD-3000/5000
01KD140047	N.47. Gearbox for KD-6500/14000
01KP050047	N.47. End cover for KDP-3000/5000
01KD120047	N.47. End cover for KDP-6500/12000
01KD140048	N.48. Oil pump cover KD-3000/14000
01KD140049	N.49. Oil pump gasket KD-3000/14000
01KD140050	N.50. Oil pump attack gear KD-3000/14000
01KD140051	N.51. Oil pump gear KD-3000/14000
01KD140052	N.52. Lock nut for KD-3000/14000
01KD050053	N.53. Gasket for KD-3000/5000
01KD140053	N.53. Gasket for KD-6500/14000
01KD050054	N.54. Gearbox cover for KD-3000/5000
01KD140054	N.54. Gearbox cover for KD-6500/14000
01KD140055	N.55. T-connection for KD-3000/14000
01KD050056	N.56. Small gear 19 teeth KD-3000/5000
01KD140056	N.56. Small gear 28 teeth KD-6500/14000
01KD141056	N.56. Small gear 1000 rpm KD-6500/14000
01KD140057	N.57. Seal for KD-3000/14000 12x20x5
01KD140058	N.58. Pipette for KD-3000/14000
01KD140059	N.59. PTO Guard for KD-3000/14000
01KD140060	N.60. Rotor plug for KD-3000/14000

01KD140061	N.61. 1/2" plug for KD-3000/14000
01KD140062	N.62. Nut for KD-3000/14000
01KD140063	N.63. PTO Guard screw KD-3000/14000
01KP120064	N.64. Nipple for KDP-3000/12000
01KP120065	N.65. Elbow 1/2 for KDP-3000/12000
01KP120066	N.66. Nipple 1/8K for KDP-3000/12000
01KD140067	N.67. Bracket for KD-3000/14000
01KD140071	N.71. Cover for KD-14000
01KD140072	N.72. Cover gasket for KD-14000
01KD140073	N.73. Purge plug for KD-14000
01KD050099	N.99. Accessories kit for KD-3000/5000
01KD060099	N.99. Accessories kit for KD-6500
01KD140099	N.99. Accessories kit for KD-6500/14000

## 5.- Warranty.

Each pump is checked in our Test-bank by vacuum and pressure before leaving our Works, being the oil system regulated as well. Thereafter each vacuum pump is identified with a manufacture number.

Our pumps have one year warranty after delivery against defects of material or assembly. HERTELL S.COOP is not responsible of direct or indirect costs caused by the pump misuse. In case of reclamation, it is decision of Hertell S.Coop. to verify the origin of the claim. It is the responsibility of the tank manufacturer to verify that the pump is going to be used according to the advised instructions.

The vacuum pumps fulfil the 89/392/CEE directive about machines (partly completed machine) and its posterior modification 98/37/CEE and 2006/42/CEE, according to the norms concerning vacuum pumps and compressors UNE - EN 1012-1 and UNE - EN 1012-2. By request a certificate according to this directive is available

### **HERTELL S.COOP.**

Industrialdea 2  
20267 Ikaztegieta

**SPAIN**

Tel: + 34 943653240

Fax: + 34 943653332

E-mail: [info@hertell.net](mailto:info@hertell.net)

<http://www.hertell.net>