

Kiekis	Aprašymas
--------	-----------

1

COMFORT 15-14 B TA



Atkreipkite dėmesį! Paveikslėlyje parodytas produktas gali skirtis nuo tikrojo

Produkto Nr.: [97916757](#)

COMFORT TA is an efficient circulator designed for hot-water recirculation in residential buildings with a dedicated return line. It is compatible with all types of water heater tanks, tankless systems, solar or heat pumps regardless of whether the system has mixing or tampering valves installed.

The pump features a compact housing and a permanent magnet with an integrated control unit.

The spherical rotor, equipped with an impeller, ensures optimal functionality supported by a robust single-bearing ball system.

The drinking-water approved brass pump housing guarantees both safety and reliability.

COMFORT TA moreover features a built-in temperature sensor to maintain water temperature.

The user-friendly interface features LEDs and push-buttons on the operating panel. This offers an intuitive way to display and set operating times and control modes and ensures a comfortable and energy-efficient experience for residential use.

COMFORT TA features three control modes: AUTOADAPT, temperature and continuous 24/7.

AUTOADAPT control mode

With the AUTOADAPT control mode, the pump quickly learns usage patterns throughout the day and ensures hot water is available only when needed via an external sensor on the supply pipe.

The pump can therefore differentiate between mornings, evenings, weekdays, weekends, and periods of inactivity, such as vacations, saving energy and water by allowing the pump only to operate when required.

After 24 hours of detecting no hot water usage, the pump automatically enters vacation mode and resumes operation when demand for hot water arises.

During the first two weeks after installation, the pump frequently starts based on temperature control to ensure immediate comfort until the usage pattern has been learned. The pump provides, regardless of usage pattern, instant comfort when it detects demand for hot water.

Once a week, the pump runs a 15-minute disinfection (anti-legionella) cycle. The water heater must enable that function once a week.

Temperature control mode

The temperature control mode incorporates both the external and internal sensors for more accurate water temperature measurement and activates the pump when the water temperature drops below a certain level.

The on/off temperatures are automatically adjusted based on the maximum temperature measured in the system.

The maximum temperature of the system is measured constantly, allowing dynamic adjustment of the on/off temperatures.

This mode also includes automatic vacation mode for enhanced energy efficiency which makes it ideal for vacation homes.

Continuous 24/7 control mode

Pump operates continuously 24 hours a day.

The product offers:

-

Kiekis	Aprašymas
--------	-----------

1

Q-H performance that is designed for single—and multi-family homes, depending on the required duty point to accommodate heat loss in a specific pipe layout.

- Heat loss reduction by 67 % compared to continuously running pump.
- Low power consumption and silent operation.
- Compliance with pipe manufacturers' flow velocity limits, including DN 15, DN 20 PEX, copper, and others.
- Drinking-water approval, ensured by the brass pump housing, stainless-steel rotor, and composite impeller.
- A design that makes it easy to clean limescale and foreign deposits by removing the pump head, enabling the product to meet unlimited water hardness requirements.
- Dry-running protection to prevent failure if the system runs out of water.
- Multiple installation positions, even with the pump head pointing downwards.
- A pump head designed to fit brass pump housings of old and new pumps of the same design, even from different pump manufacturers (such as WILO, VORTEX, LOWARA, DAB and others).

The design enables easy installation and removes the need to replace the pump housing and drain the system.

- Easy electrical installation, which is provided by a pre-assembled power plug with a 1.5 m cable and a double insulation protection design, which eliminates the need for a ground wire.
- Insulating shells for heat loss reduction.
- Non-return and shut-off valves included in "BX" variant, reducing installation cost.
- An optional venting flange that provides a simple way to vent or drain the system without the need to install an additional venting valve permanently.
- Optional fittings for pipe connections in different sizes and types.
- Optional non-return and shut-off valves are available.

97916757 COMFORT 15-14 B TA

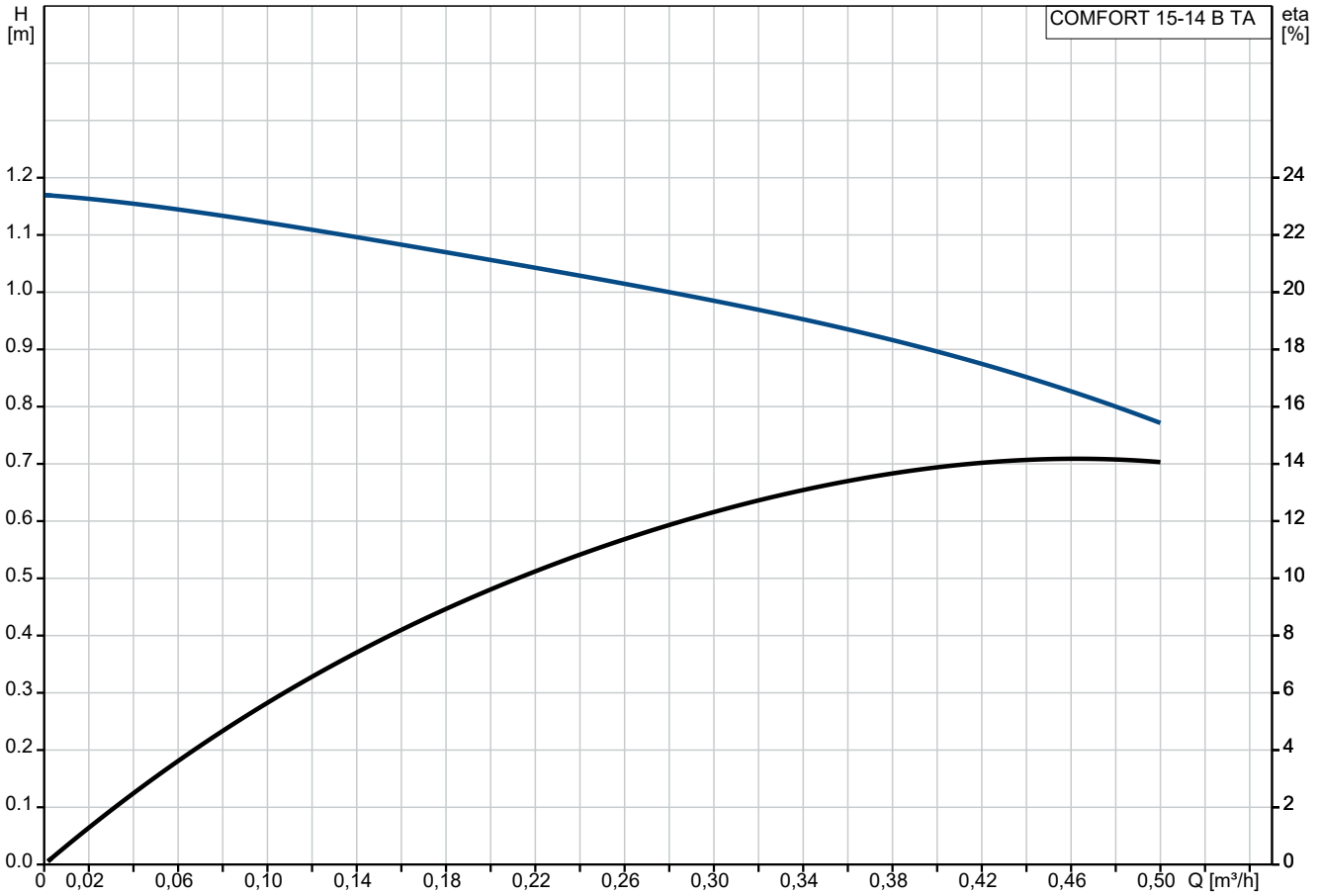

Siurbiamas skystis = Vanduo
Skysčio temperatūra darbo metu = 60 °C
Tankis = 983.2 kg/m³

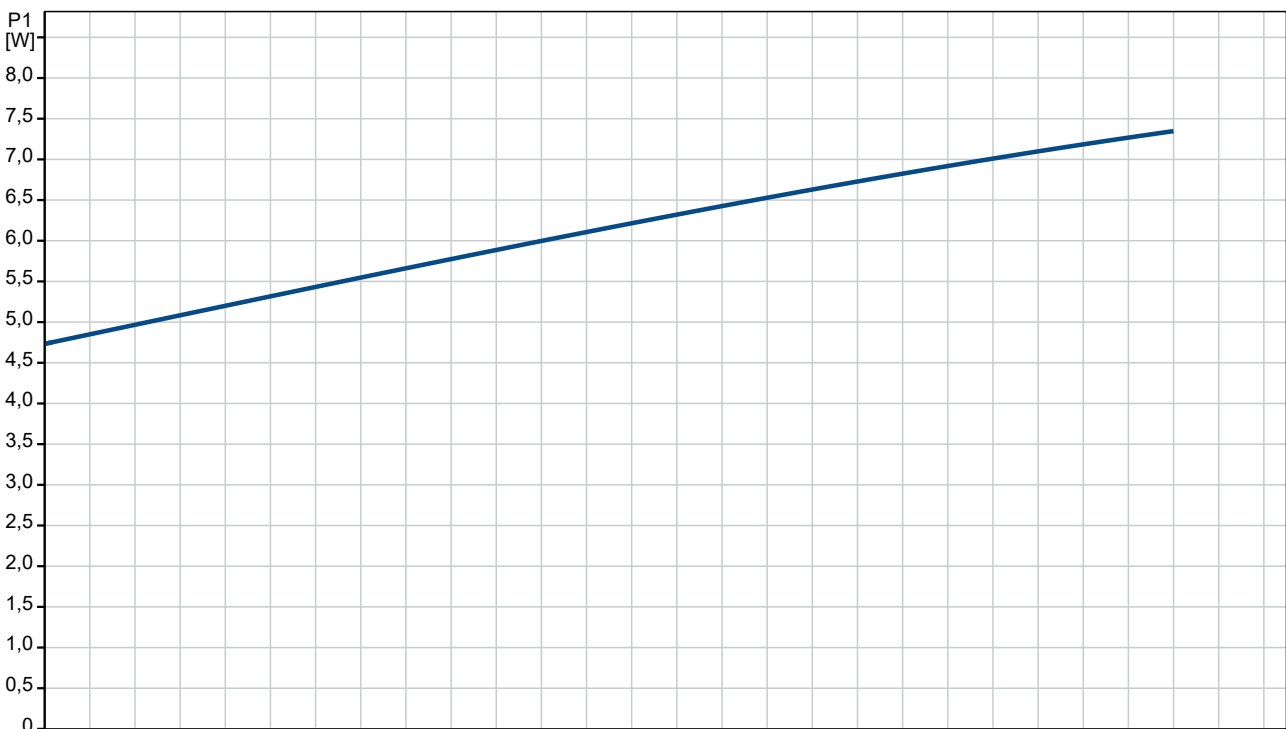

Aprašymas	Vertė
-----------	-------

Bendra informacija:

Produkto pavadinimas: COMFORT 15-14 B TA

Produkto Nr.: 97916757

EAN numeris: 5710626363506

Techniniai duomenys:

Greičių skaičius: 1

Nominalus debitas: 0.45 m³/h

Nominalus slėgio aukštis: 0.9 m

Maximum head: 14 dm

TF klasė: 95

Sertifikatai: CE, VDE, EAC, WEEE

Medžiagos:

Siurblio korpusas: Žalvaris

Siurblio korpusas: CuZn39Pb3, MS58

Darbaratis: Kompozitas

Darbaratis: PPO-GF20/Stainless steel

Įrengimas:

Minimali aplinkos temperatūra: 0 °C

Maksimalus darbinis slėgis: 10 bar

Jungties tipas: Rp

Jungties dydis: 1/2 inch

Vamzdžio jungties slėgio klasė: PN 10

Port-to-port length: 80 mm

Skystis:

Siurbiamas skystis: Vanduo

Skysčio temperatūros diapazonas: 2 .. 95 °C

Skysčio temperatūra eksploataavimo metu: 60 °C

Tankis: 983.2 kg/m³

Elektrotechniniai duomenys:

Maks. naudojama galia: 7 W

Elektros tinklo dažnis: 50 / 60 Hz

Nominali įtampa: 1 x 230 V

Srovė esant greičiui 3: 0.07 A

Korpuso klasė (IEC 34-5): IP44

Izoliacijos klasė (IEC 85): F

Integruota variklio apsauga: ELECT.

Šiluminė apsauga: IMP.

Valdikliai:

Operation mode include: Temperature

Kita:

Neto masė: 0.98 kg

Bruto masė: 1.08 kg

Tiekimo tūris: 0.003 m³

Danijos VVS Nr.: 380634014

Švedijos RSK Nr.: 5803088

Norvegijos NRF Nr.: 9042115

Kilmės šalis: DE

Muitinės kodas: 84137030

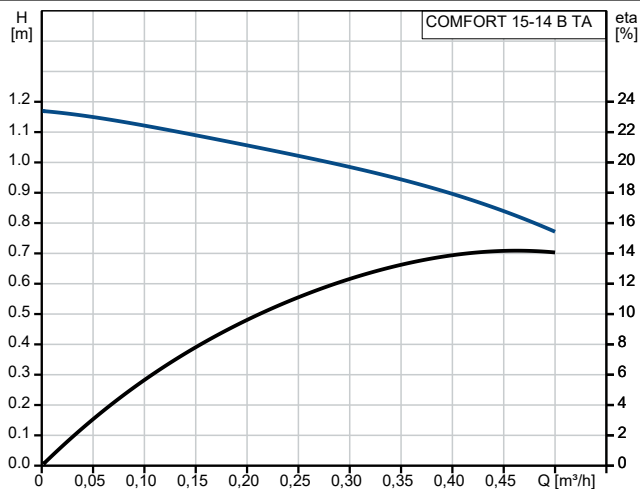

Siurbiamas skystis = Vanduo
Skysčio temperatūra darbo metu = 60 °C
Tankis = 983.2 kg/m³

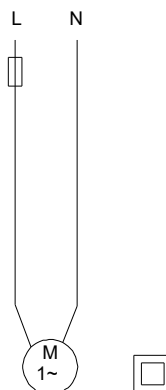
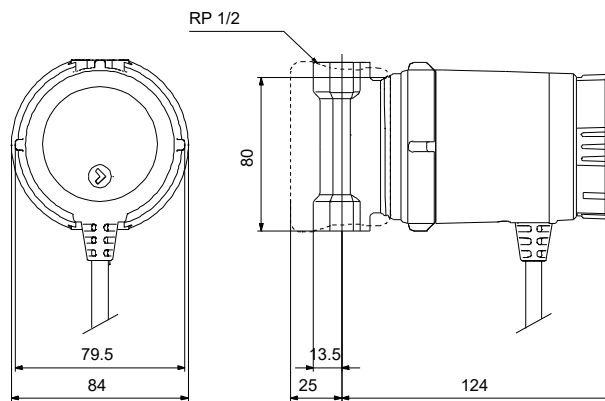
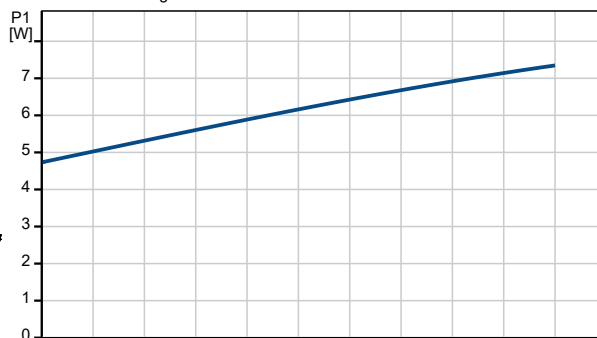

97916757 COMFORT 15-14 B TA

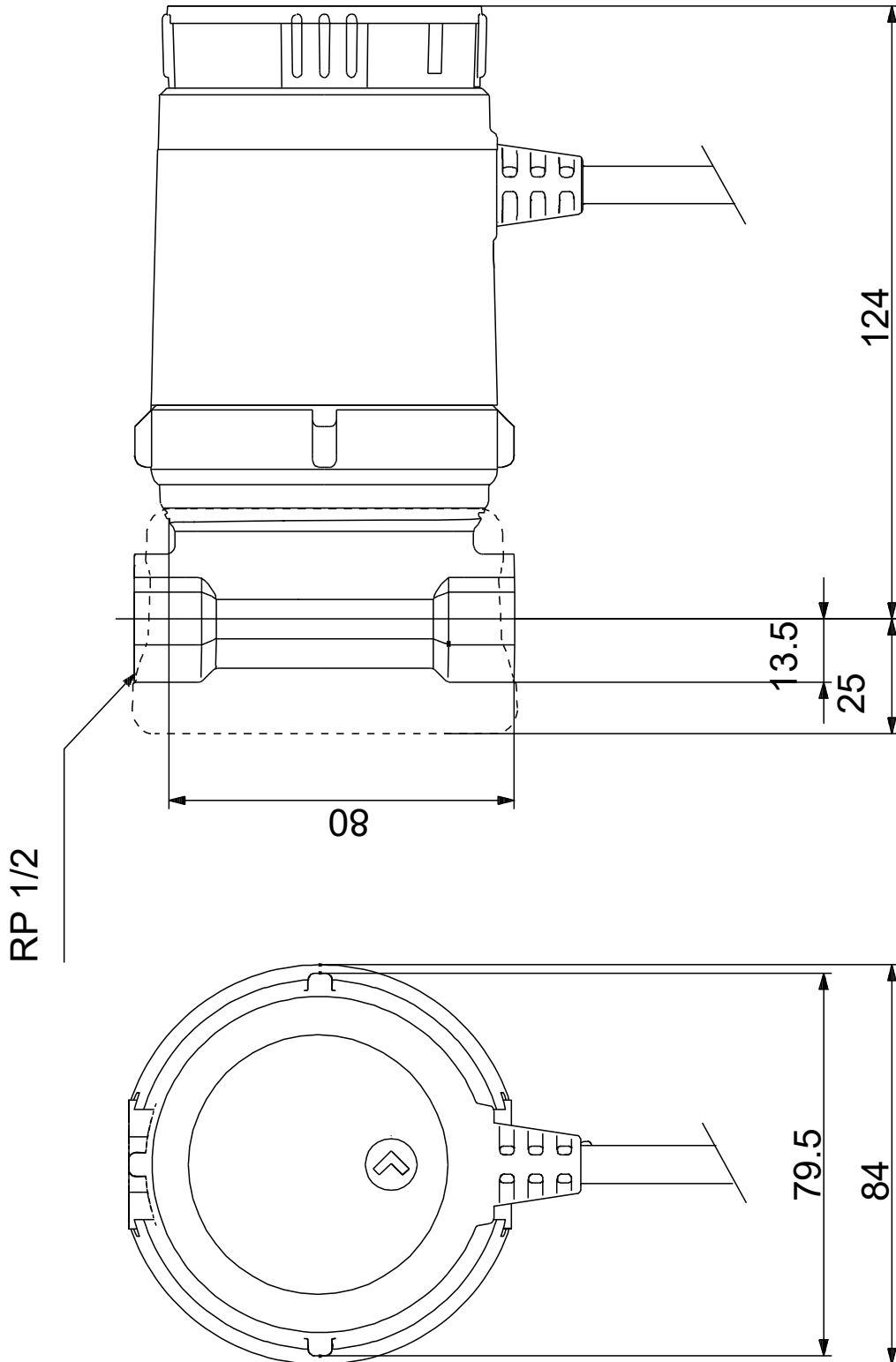

Atkreipkite dėmesį! Visi matmenys, jei nenurodyta kitaip, pateikti milimetrais.
Atsakomybės apribojimas: šiame supaprastintame matmenų brėžinyje neparodytos visos detalės.

97916757 COMFORT 15-14 B TA



Atkreipkite dėmesį! Visi matmenys, jei nenurodyta kitaip, pateikti milimetrais.