



VS 6" - 8" SERIES 60 HZ

SUBMERSIBLE PUMPS FOR 4" DEEP WELLS OR LARGER



INDEX

6" Stainless Steel submersible pumps	4
Family curves.....	5
Pump identification code.....	5
Pumps and motors range.....	5
Materials/fluids compatibility.....	6
Table of hydraulic performance at 60 Hz	7
VS 14.....	7
VS 19.....	8
VS 25*.....	9
VS 30.....	10
VS 46.....	11
VS 65.....	12
Technical data and performance curves	14
VS 14.....	14
VS 14 High pressure.....	18
VS 19.....	20
VS 19 High pressure.....	22
VS 25*.....	24
VS 25* High pressure.....	26
VS 30.....	28
VS 30 High pressure.....	30
VS 46.....	32
VS 46 High pressure.....	34
VS 65.....	36
VS 65 High pressure.....	38
Spare parts	40
VS 14-19-25*.....	40
VS 30-46-65.....	41
Motor adapter and dimensions	42
VS 14-19-25*.....	42
VS 30-46-65.....	43
8" Stainless Steel submersible pumps	46
Family curves.....	47
Pump identification code.....	47
Pumps and motors range.....	47
Materials/fluids compatibility.....	48
Hydraulic performance at 60 Hz	49
VS 78.....	49
VS 97.....	49
Technical data and performance curves	50
VS 78.....	50
VS 97.....	52
Spare parts	54
VS 78-97.....	54
Motor adapter and dimensions	55
VS 78-97.....	55

* IMPORTANT: VS25 models only for sales out of EU or as a component of fire-fighting units

NOTE: Franklin Electric S.r.l. reserves the right to amend specification without prior notice

For the most up-to-date product information, visit franklinwater.eu



VS 6" Series

VS 14-19-25-30-45-65

6" STAINLESS STEEL SUBMERSIBLE PUMPS

APPLICATION

- Municipal water works
- Water distribution and pressure boosting
- Irrigation and sprinkler systems, water treatment plants, filtration and reverse osmosis
- Industrial cooling and processing
- Mining industry, drainage and dewatering
- Fire-fighting equipment
- Fountains

FEATURES

- Fabricated stainless steel impellers and diffusers for corrosion resistance
- Heavy-duty stainless-steel structure for improved stiffness and ensuring the permanent alignment of all components and thus increased run time and trouble-free operation
- Floating Neck ring in PPS (14-19-25*) or in PTFE (30-46-65)
- Reinforced version with double welded rings for high pressure pumps
- Compact, reliable and suited to operate in horizontal position
- Built-in check valve to protect the pump against water hammer risk
- The hydraulic design is such to enhance the overall efficiency thus reducing energy consumption and making the pumping systems more cost effective

PUMP SPECIFICATION

- Flow: up to 100 m³/h at 60 Hz
- Head: up to 744 m (73 Bar) at 60 Hz
- Water temperature range:
 - Minimum: -5 °C
 - Maximum: +90 °C (+60 °C for NBR parts)
- Maximum allowable amount of sand 100 g/m³
- Rotation: counterclockwise when looking into the discharge
- Pump can work continuously in vertical or horizontal position

MOTOR SPECIFICATION

- Motor adapter in compliance with NEMA standard
- For more information consult the product catalog of Submersible motors

AVAILABLE ON REQUEST

- Pump material:
 - 316 Stainless steel (N) version (DIN/EN 1.4401)
 - 904L (R) version (DIN/EN 1.4539)
 - See specified material variant in "Materials/Fluids compatibility" table on page 7
- Double cable guard (SD version)
- Discharge heads:
 - Rp 2" (with kit adapter 2"1/2-2" PN 14251008) and Rp 3" for 14 and 19 I and N versions
 - Rp 4" for 25*-30-46-65 I and N versions
- Motor adapter:
 - 4" for I and N version
 - 8" for I and N version
- Pump with NBR rubber parts

* IMPORTANT: VS25 models only for sales out of EU or as a component of fire-fighting units

FAMILY CURVES

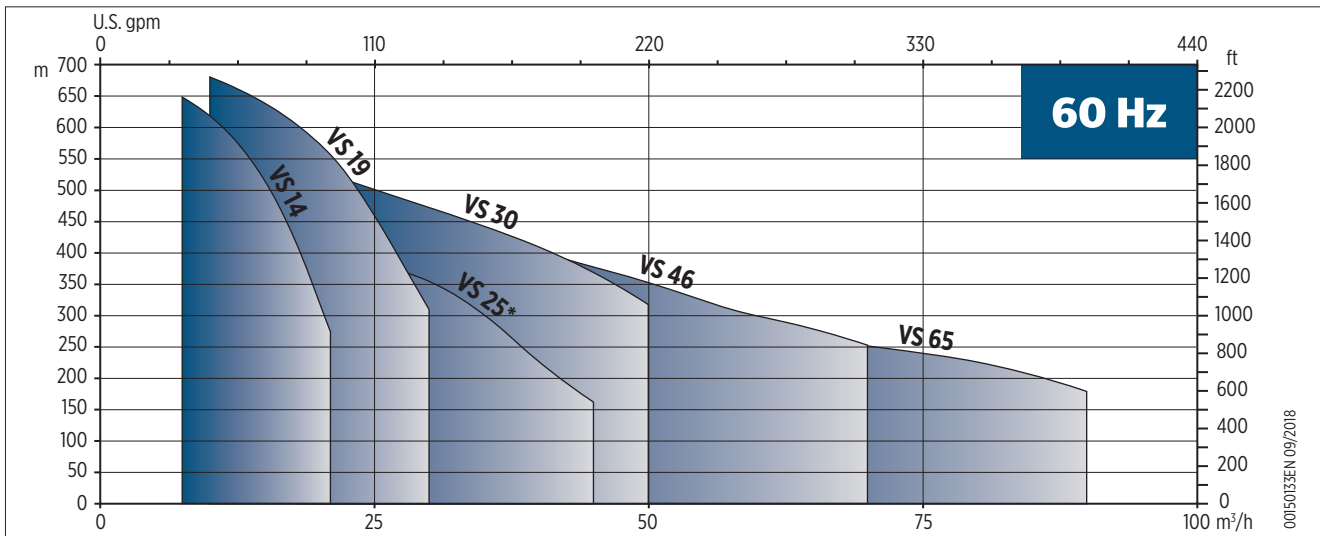

PUMP IDENTIFICATION CODE

VS 14 / 15 I M6 RP5 E1 P HP SD

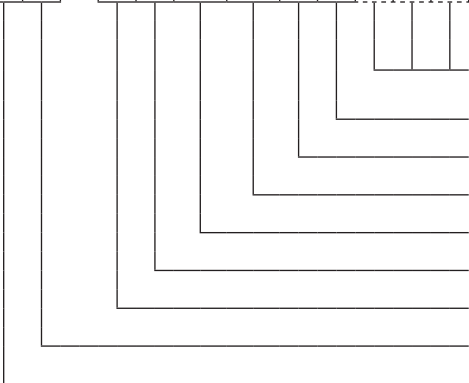

- Pump speciality: P (Passivated); HP (High pressure); SD (Double cable guard)
- Bearing bush material: E1 (EPDM)
- Frequency: 50 (50 Hz); 60 (60 Hz)
- Discharge head (threaded type and dimension): Rp(X); NPT(X)
- Motor coupling dimension: M6 (6")
- Material: I (AISI 304); N (AISI 316); R (AISI 904L)
- Number of stages
- Nominal flow in m³/h
- Pump model

00140101 06/2021

PUMPS AND MOTORS RANGE

Pump model	Versions			Motor power range [kW]	
	I EN 1.4301	N EN 1.4401	R EN 1.4539	I e N	R
VS 14	○	○	-	4 ÷ 30	-
VS 19	○	○	-	4 ÷ 37	-
VS 25*	○	○	-	4 ÷ 45	-
VS 30	○	○	●	3 ÷ 55	4 ÷ 37
VS 46	○	○	●	3.7 ÷ 55	4 ÷ 37
VS 65	○	○	●	3.7 ÷ 55	4 ÷ 37

○ = Version available ● = Version available only with 6" motor coupling

* IMPORTANT: VS25 models only for sales out of EU or as a component of fire-fighting units

MATERIALS/FLUIDS COMPATIBILITY

Ref. No.	Parts description	Material	Standard					
			I Version		N Version		R Version	
			ASTM	DIN/EN	ASTM	DIN/EN	ASTM	DIN/EN
10.00	Discharge head	Stainless steel	CF8 (304)	1.4308	CF8M (316)	1.4408	CD4MCuN (904L)	1.4517
10.01 10.04 10.05	Valve	Stainless steel	316	1.4401	316	1.4401	2205/904L	1.4462/1.4460
10.02	Sealing O-ring		EPDM					
10.03	Outer case locking nuts	Stainless steel	316	1.4401	316	1.4401	2205	1.4462
20.00	Outer case	Stainless steel	304	1.4301	316	1.4401	2205	1.4462
20.01	Suction strainer	Stainless steel	316	1.4401	316	1.4401	904L	1.4539
20.02	Cable guard and screws	Stainless steel	316	1.4401	316	1.4401	904L	1.4539
20.03	Initial spacer	Stainless steel	304	1.4301	316	1.4401	904L	1.4539
20.04	Flange	Stainless steel	CF8 (304)	1.4308	CF8M (316)	1.4408	CD4MCuN (904L)	1.4517
	Screws		304	1.4301	316	1.4401	904L	1.4539
20.05	Motor adapter	Stainless steel	CF8 (304)	1.4308	CF8M (316)	1.4408	CD4MCuN (904L)	1.4517
20.06	4" motor flange	Stainless steel	CF8M (316)	1.4408	CF8M (316)	1.4408	-	-
	4" coupling adapter		316	1.4401	316	1.4401		
20.07	8" motor adapter (30/46/65)	Stainless steel	CF8M (316)	1.4408	CF8M (316)	1.4408	-	-
	Bolts and washers (30/46/65)		316	1.4401	316	1.4401		
30.00	Pump shaft	Stainless steel	431	1.4057	316/329	1.4401/1.4460	329	1.4460
30.01	Coupling	Stainless steel	431/329	1.4057/1.4460	316/329	1.4401/1.4460	904L/329	1.4462/1.4539 1.4460
30.02	Upper up-thrust washer	Stainless steel	316	1.4401	316	1.4401	329	1.4460
30.03	Lower up-thrust washer	Stainless steel	316	1.4401	316	1.4401	329	1.4460
30.04	Upper journal sleeve	Alluminum Oxide	Al2 O3 (99,7%)					
30.05	Screw and washer	Stainless steel	316	1.4401	316	1.4401	904L/329	1.4539/1.4460
30.06	Up-thrust ring		PTFE + Grafite					
30.07 30.08	Lower / Upper spacer	Stainless steel	316	1.4401	316	1.4401	-	-
40.00	Diffuser	Stainless steel	304	1.4301	316	1.4401	904L	1.4539
40.01	Secondary bearing bush		EPDM					
40.02	Floating neck ring		PPS (14/19/25)					
			PTFE (30/46/65)					
40.03	Flange clamping neck ring (30/46/65)	Stainless steel	304	1.4301	316	1.4401	904L	1.4539
40.04	Bearing bush		EPDM					
40.05	Upper bearing guide (14/19/25*)	Stainless steel	CF8M (316)	1.4408	CF8M (316)	1.4408	-	-
	Last - Intermediate diffuser (30/46/65)		316	1.4401	316	1.4401	904L	1.4539
40.06	First diffuser (14/19/25*)	Stainless steel	316	1.4401	316	1.4401	-	-
40.07	Diffuser with upper up-thrust washer (14/19/25*)	Stainless steel	316	1.4401	316	1.4401	-	-
40.08	Last diffuser (14/19/25*)	Stainless steel	316	1.4401	316	1.4401	-	-
50.00	Impeller	Stainless steel	304	1.4301	316	1.4401	904L	1.4539
50.05	Wear ring	Stainless steel	304	1.4301	316	1.4401	904L	1.4539
50.01	Impeller spacer (14/19/25*)	Stainless steel	316	1.4401	316	1.4401	329	1.4460
51.01	Split cone (30/46/65)	Stainless steel	316	1.4401	316	1.4401	329	1.4460
51.02	Split cone nut (30/46/65)	Stainless steel	316	1.4401	316	1.4401	329	1.4460
51.03	Intermediate cone nut (30/46/65)	Stainless steel	316	1.4401	316	1.4401	329	1.4460
		Alluminum Oxide	Al2 O3 (99,7%)					
51.04	Up-thrust split cone nut (30/46/65)	Stainless steel	316	1.4401	316	1.4401	329	1.4460
51.06	Intermediate impeller with screw (30/46/65)	Stainless steel	304	1.4301	316	1.4401	904L	1.4539

* IMPORTANT: VS25 models only for sales out of EU or as a component of fire-fighting units



TABLE OF HYDRAULIC PERFORMANCE AT 60 Hz

VS 14

Pump model	RATED POWER		Q = DELIVERY								
			m ³ /h 0	6	8	10	12	14	16	18	21
	[kW]	[HP]	l/min 0	100	133.3	166.6	200	233.3	266.6	300	350
H = TOTAL HEAD METERS COLUMN OF WATER [m]											
VS 14/5	3.7	5	87.5	77.5	75.5	72.5	68.5	63.0	56.5	47.5	31.0
VS 14/6	5.5	7.5	107.0	96.0	93.5	90.0	85.5	79.0	71.0	60.5	41.0
VS 14/7	5.5	7.5	124.5	111.0	108.0	104.0	98.5	91.5	82.0	69.5	46.5
VS 14/8	5.5	7.5	142.0	126.0	122.5	118.0	111.5	103.0	92.0	78.0	52.0
VS 14/9	7.5	10	159.5	142.0	138.5	133.5	126.5	117.0	105.0	89.0	59.5
VS 14/10	7.5	10	177.0	157.0	153.0	147.0	139.0	129.0	115.0	97.5	65.0
VS 14/11	7.5	10	194.0	172.0	167.5	160.5	152.0	140.0	125.0	105.5	70.0
VS 14/12	9.3	12.5	213.0	190.0	185.5	178.5	169.0	157.0	140.5	119.5	80.0
VS 14/13	9.3	12.5	230.0	205.0	200.0	192.5	182.0	169.0	151.0	128.0	85.5
VS 14/14	11	15	249.0	221.5	216.0	208.0	197.0	182.5	163.5	139.0	93.0
VS 14/15	11	15	266.0	236.5	230.5	221.5	210.0	194.0	174.0	147.5	98.0
VS 14/16	11	15	283.0	251.5	245.0	235.5	222.5	206.0	184.0	156.0	103.5
VS 14/17	11	15	300.5	266.0	259.0	249.0	235.0	217.5	194.0	164.0	108.5
VS 14/18	15	20	320.0	285.0	277.5	267.0	253.0	234.5	210.0	178.5	119.5
VS 14/19	15	20	337.0	300.0	292.0	281.0	266.0	246.0	220.5	187.0	125.0
VS 14/20	15	20	354.0	315.0	306.5	295.0	279.0	258.0	230.5	195.5	130.0
VS 14/21	15	20	371.5	330.0	321.0	308.0	291.5	269.5	241.0	203.5	135.0
VS 14/22	15	20	388.5	344.5	335.0	322.0	304.0	281.0	251.0	212.0	140.0
VS 14/23	18.5	25	408.5	363.5	354.0	341.0	322.5	299.0	268.0	227.0	152.0
VS 14/24	18.5	25	425.5	378.5	368.5	354.5	335.5	311.0	278.0	236.0	157.0
VS 14/25	18.5	25	443.0	393.5	383.0	368.5	348.5	322.5	288.5	244.0	162.5
VS 14/26	18.5	25	460.0	408.0	397.5	382.0	361.0	334.0	298.5	252.5	168.0
VS 14/27	18.5	25	477.0	423.0	411.5	395.5	374.0	345.5	308.5	261.0	173.0
VS 14/28	18.5	25	494.0	438.0	426.0	409.0	386.5	357.0	318.5	269.0	178.0
VS 14/29	22	30	513.0	455.0	443.0	425.5	402.0	371.5	332.0	281.0	186.0
VS 14/30	22	30	530.0	470.0	457.0	439.0	414.5	383.0	342.0	289.0	191.0
VS 14/31	22	30	547.0	484.5	471.0	452.0	427.0	394.0	352.0	297.0	196.0
VS 14/32	22	30	564.0	499.0	485.0	465.5	439.5	405.5	361.5	305.0	201.0
VS 14/33 HP	30	40	588.0	525.5	512.5	494.0	468.5	435.0	390.0	332.5	224.0
VS 14/34 HP	30	40	605.5	540.5	527.5	508.0	421.5	447.0	401.0	341.5	229.5
VS 14/35 HP	30	40	623.0	556.0	542.0	522.0	495.0	459.0	411.5	350.0	235.5
VS 14/36 HP	30	40	640.5	541.0	559.0	536.0	508.0	471.0	422.0	359.0	241.0
VS 14/37 HP	30	40	657.5	586.0	517.5	550.0	521.0	483.0	411.0	368.0	246.5
VS 14/38 HP	30	40	675.0	601.5	586.0	564.0	534.0	495.0	449.5	376.5	252.0
VS 14/39 HP	30	40	692.0	616.5	600.5	578.0	547.0	507.0	454.0	385.0	257.5
VS 14/40 HP	30	40	709.5	637.5	615.0	592.0	560.0	518.5	464.0	393.5	262.7
VS 14/41 HP	30	40	727.0	646.5	629.5	605.5	573.0	530.0	474.5	402.0	268.0
VS 14/42 HP	30	40	744.0	661.5	644.0	619.0	585.5	542.0	484.5	410.5	273.5

VS 19

Pump model	RATED POWER		Q = DELIVERY								
			m ³ /h 0	12	15	18	21	24	27	30	32
	[kW]	[HP]	l/min 0	200	250	300	350	400	450	500	533.3
H = TOTAL HEAD METERS COLUMN OF WATER [m]											
VS 19/3	4	5.5	54.0	48.0	45.5	43.0	39.0	34.0	28.0	22.0	17.5
VS 19/4	5.5	7.5	74.0	66.0	63.5	60.0	55.5	49.0	40.5	32.5	26.0
VS 19/5	5.5	7.5	92.0	82.0	78.5	73.5	68.0	59.5	49.5	39.0	31.5
VS 19/6	7.5	10	110.0	98.5	94.0	88.5	81.5	71.5	59.5	47.5	38.0
VS 19/7	7.5	10	128.0	113.5	108.5	102.0	94.0	82.0	68.0	54.0	43.0
VS 19/8	9.3	12.5	147.0	131.5	126.0	118.5	109.5	96.0	80.0	63.5	51.0
VS 19/9	9.3	12.5	165.0	147.0	140.5	132.5	122.0	107.0	88.5	70.0	56.0
VS 19/10	11	15	177.0	159.5	153.0	145.0	134.0	117.0	96.5	74.5	58.0
VS 19/11	11	15	194.0	174.5	167.5	158.0	146.0	127.5	105.0	81.0	62.0
VS 19/12	15	20	212.5	190.0	185.0	175.0	161.5	141.0	117.0	90.5	70.5
VS 19/13	15	20	230.0	207.0	199.0	188.0	174.0	152.0	125.0	97.0	75.0
VS 19/14	15	20	247.0	222.0	213.0	201.0	186.0	162.5	133.5	103.0	79.0
VS 19/15	15	20	261.0	237.0	227.0	214.0	197.5	172.0	141.5	109.0	83.5
VS 19/16	18.5	25	283.0	255.0	245.0	232.0	214.0	187.5	154.5	119.5	92.5
VS 19/17	18.5	25	300.0	270.0	259.5	245.0	226.5	198.0	162.5	125.5	97.0
VS 19/18	18.5	25	317.5	285.0	273.5	258.0	238.0	208.0	171.0	132.0	101.0
VS 19/19	22	30	335.5	301.5	298.5	273.5	525.5	220.5	181.0	140.0	108.0
VS 19/20	22	30	352.5	316.5	303.5	286.5	264.0	230.5	189.0	146.0	112.0
VS 19/21	22	30	369.5	331.0	317.0	299.0	276.0	240.5	197.0	152.0	116.0
VS 19/22	22	30	356.5	345.5	331.0	312.0	289.0	250.0	205.0	157.5	119.5
VS 19/23	30	40	408.5	370.0	356.0	337.0	312.0	274.0	226.5	176.0	137.5
VS 19/24	30	40	426.0	385.5	370.5	351.0	325.0	285.0	236.0	182.5	142.5
VS 19/25	30	40	443.0	400.5	385.0	364.0	337.0	295.5	243.5	189.0	147.0
VS 19/26	30	40	460.5	415.5	399.5	378.0	349.5	306.0	252.0	195.5	152.0
VS 19/27	30	40	477.5	430.5	414.0	391.0	361.5	316.5	260.5	201.5	156.5
VS 19/28	30	40	495.0	445.5	428.0	404.5	373.5	327.0	269.0	208.0	161.0
VS 19/29	30	40	512.0	460.5	442.0	417.5	385.5	337.0	277.0	214.0	165.0
VS 19/30	30	40	529.0	475.5	456.0	430.5	397.5	347.0	285.0	220.0	169.0
VS 19/31 HP	37	50	548.0	494.0	474.5	448.0	414.0	362.5	298.0	231.0	178.5
VS 19/32 HP	37	50	565.5	508.5	488.5	461.5	426.5	373.0	306.5	237.0	183.0
VS 19/33 HP	37	50	582.0	523.5	502.5	474.5	438.0	383.0	314.5	243.0	187.0
VS 19/34 HP	37	50	599.0	538.5	516.5	488.0	450.0	393.0	322.5	285.0	191.5
VS 19/35 HP	37	50	616.5	553.0	530.5	500.5	462.0	403.0	330.5	255.0	195.0
VS 19/36 HP	37	50	633.5	568.0	544.5	513.5	473.5	413.0	338.5	261.0	199.0
VS 19/37 HP	45	60	655.0	591.0	568.5	537.5	497.0	435.5	358.5	278.0	216.0
VS 19/38 HP	45	60	672.0	206.5	528.5	551.0	509.0	446.0	367.0	284.0	220.5
VS 19/39 HP	45	60	689.0	621.5	597.0	564.0	521.5	456.0	375.0	260.5	225.0
VS 19/40 HP	45	60	706.5	636.0	611.0	577.5	533.5	466.5	393.5	296.5	229.0
VS 19/41 HP	45	60	723.5	651.0	625.0	590.5	545.5	476.5	392.0	303.0	233.5
VS 19/42 HP	45	60	741.0	666.0	639.0	603.5	557.0	487.0	400.0	309.0	237.5

VS 25*

* IMPORTANT: Models only for sales out of EU or as a component of fire-fighting units

Pump model	RATED POWER		Q = DELIVERY									
			m ³ /h 0	16	20	24	28	32	36	40	45	50
	[kW]	[HP]	l/min 0	266,6	333,3	400	466,6	533,3	600	666,6	750	833,3
H = TOTAL HEAD METERS COLUMN OF WATER [m]												
VS 25/3	5,5	7,5	55,5	49,5	48,0	47,0	45,5	42,5	38,0	32,5	26,5	20,5
VS 25/4	7,5	10	73,5	65,5	64,0	62,5	60,0	56,5	50,5	43,0	35,0	27,0
VS 25/5	9,3	12,5	92,0	82,5	80,5	78,5	76,0	71,5	64,0	54,5	44,5	34,0
VS 25/6	11	15	110,5	99,0	96,5	94,0	90,5	85,0	76,5	65,0	53,0	40,5
VS 25/7	11	15	128,5	114,0	111,5	108,5	104,5	98,0	87,5	74,0	60,5	46,0
VS 25/8	15	20	147,0	131,5	128,0	145,0	120,5	113,0	101,0	86,0	70,0	53,5
VS 25/9	15	20	165,0	147,0	143,0	139,5	134,0	126,0	112,0	95,5	77,5	59,0
VS 25/10	18,5	25	184,0	164,0	160,0	156,0	150,5	141,5	126,5	107,5	87,5	67,0
VS 25/11	18,5	25	202,0	180,0	175,0	170,5	164,0	154,0	137,5	117,0	95,0	72,5
VS 25/12	22	30	220,0	196,0	191,0	186,0	179,0	168,0	150,0	127,5	104,0	79,0
VS 25/13	22	30	238,0	211,5	206,0	200,5	193,0	180,5	161,0	136,5	111,0	84,5
VS 25/14	22	30	255,5	226,5	220,5	214,5	206,0	193,0	171,0	145,5	118,0	89,5
VS 25/15	30	40	277,0	248,0	241,5	236,0	227,5	214,5	192,5	163,5	133,0	102,5
VS 25/16	30	40	295,0	263,5	257,0	251,0	242,0	227,5	204,0	173,0	141,0	108,0
VS 25/17	30	40	312,5	279,0	272,0	265,5	255,5	240,5	215,0	183,0	148,5	114,0
VS 25/18	30	40	330,5	295,0	287,0	280,0	269,5	253,0	226,0	192,0	156,0	119,0
VS 25/19	30	40	348,5	310,0	302,0	294,5	283,0	265,5	237,0	201,0	163,5	124,5
VS 25/20	37	50	367,0	327,5	319,0	311,5	299,5	281,5	251,5	214,0	174,0	133,0
VS 25/21	37	50	385,0	343,0	334,0	326,0	313,5	294,0	262,5	223,0	181,0	138,0
VS 25/22	37	50	403,0	358,5	349,0	340,0	327,0	306,5	273,0	232,0	188,5	143,5
VS 25/23	37	50	420,5	313,5	363,5	354,0	340,5	319,0	284,0	241,0	196,0	148,5
VS 25/24 HP	45	60	441,5	394,5	384,0	375,0	361,0	339,5	303,5	258,0	210,0	161,0
VS 25/25 HP	45	60	459,0	410,0	399,0	389,5	375,0	352,0	315,0	267,5	217,5	166,0
VS 25/26 HP	45	60	477,0	425,0	414,0	404,0	388,5	365,0	326,0	277,0	225,0	171,5
VS 25/27 HP	45	60	495,0	440,5	429,0	418,0	402,0	377,5	336,5	286,0	232,5	177,0
VS 25/28 HP	45	60	512,5	456,0	444,0	432,5	416,0	390,0	347,0	295,0	239,5	182,0

VS 30

Pump model	R vers.	RATED POWER		Q = DELIVERY								
				m ³ /h 0	20	25	30	35	40	45	50	55
		[kW]	[HP]	l/min 0	333.3	416.6	500	583.3	666.6	750	833.3	916.6
H = TOTAL HEAD METERS COLUMN OF WATER [m]												
VS 30/3	●	5.5	7.5	67.0	55.0	51.5	48.5	45.0	41.0	36.0	30.0	22.5
VS 30/4	●	7.5	10	89.0	73.0	68.5	64.0	59.5	54.5	48.0	40.0	29.5
VS 30/5	●	9.3	12.5	111.0	92.0	87.0	72.0	76.0	70.0	62.0	52.0	39.5
VS 30/6	●	11	15	133.0	110.0	104.0	98.0	91.0	84.0	74.0	62.0	47.0
VS 30/7	●	15	20	156.0	129.5	122.5	115.5	107.5	99.0	88.0	74.5	57.5
VS 30/8	●	15	20	177.0	146.5	138.5	130.5	121.0	111.5	99.0	83.5	64.0
VS 30/9	●	18.5	25	201.5	167.5	178.0	149.0	138.0	128.0	114.0	97.0	76.0
VS 30/10	●	18.5	25	222.5	185.0	174.5	164.0	152.0	141.0	125.0	106.0	82.5
VS 30/11	●	22	30	245.0	203.5	192.0	180.0	167.0	154.5	137.5	116.5	90.5
VS 30/12	●	22	30	265.5	220.5	207.5	195.0	180.5	167.0	148.0	125.5	97.0
VS 30/13	●	30	40	293.5	244.5	230.5	217.0	202.0	187.5	167.5	143.0	113.0
VS 30/14	●	30	40	315.0	262.0	247.0	233.0	216.0	200.5	179.0	153.0	120.0
VS 30/15	●	30	40	336.0	280.0	263.5	248.0	230.0	213.5	190.0	162.0	127.0
VS 30/16	●	30	40	357.0	297.0	280.0	263.5	244.0	226.0	201.0	171.0	133.5
VS 30/17	●	37	50	381.0	317.0	298.5	281.0	261.0	242.0	215.5	183.5	143.5
VS 30/18	●	37	50	402.0	334.0	315.0	296.0	274.5	254.5	226.5	193.0	150.5
VS 30/19	●	37	50	423.0	351.5	331.0	311.5	288.5	267.0	237.5	201.5	157.0
VS 30/20	●	37	50	443.5	369.0	347.0	326.0	312.0	279.5	248.0	210.5	163.0
VS 30/21		45	60	471.0	392.0	369.5	348.0	322.5	299.0	266.5	227.5	178.0
VS 30/22		45	60	492.0	409.5	386.0	363.0	336.5	312.0	278.0	236.5	185.0
VS 30/23		45	60	513.0	427.0	402.0	378.0	350.5	325.0	289.0	246.0	191.5
VS 30/24		45	60	534.0	444.0	418.0	393.0	364.0	337.5	299.5	254.5	198.0
VS 30/25 HP		55	75	571.0	476.0	449.5	424.5	395.0	368.0	330.0	284.0	226.5
VS 30/26 HP		55	75	593.0	494.5	467.0	441.0	410.0	381.5	342.0	294.5	234.5
VS 30/27 HP		55	75	615.0	513.0	484.0	457.0	425.0	395.5	354.5	305.0	242.5
VS 30/28 HP		55	75	637.0	531.0	501.5	473.0	440.0	409.5	367.0	315.0	250.5

● = Pump available in R version (AISI 904L)

VS 46

Pump model	R vers.	RATED POWER		Q = DELIVERY										
				m ³ /h 0	30	35	40	45	50	55	60	65	70	75
		[kW]	[HP]	l/min 0	500	583.3	666.6	750	833.3	916.6	1000	1083.3	1166.6	1250
				H = TOTAL HEAD METERS COLUMN OF WATER [m]										
VS 46/2	●	5.5	7.5	39.5	34.0	32.0	30.0	28.5	27.0	25.0	23.0	21.0	18.5	16.0
VS 46/3	●	7.5	10	58.5	50.5	47.5	44.5	42.0	39.5	37.0	34.0	31.0	27.0	23.5
VS 46/4	●	9.3	12.5	78.0	67.5	63.5	59.5	56.5	53.0	49.5	45.5	42.0	36.5	31.5
VS 46/5	●	11	15	97.0	84.0	79.0	74.0	70.0	65.5	61.0	56.5	51.5	45.0	38.5
VS 46/6	●	15	20	118.0	102.5	67.0	61.0	86.0	79.5	73.0	67.5	63.0	56.5	48.5
VS 46/7	●	15	20	136.0	118.0	111.5	104.5	98.5	91.5	84.0	77.5	72.0	64.5	55.0
VS 46/8	●	18.5	25	156.5	136.0	128.5	120.5	113.5	105.5	97.0	89.5	83.0	75.0	64.0
VS 46/9	●	18.5	25	175.0	151.5	143.0	134.0	126.5	117.0	108.0	99.5	92.0	83.0	70.0
VS 46/10	●	22	30	194.0	168.0	158.5	149.0	140.0	130.0	119.5	110.0	102.0	91.5	77.5
VS 46/11	●	22	30	211.5	183.0	172.5	162.0	152.5	141.0	129.5	120.0	110.5	99.0	83.5
VS 46/12	●	30	40	236.5	206.0	195.0	182.5	170.0	160.0	147.0	136.0	126.0	114.0	97.5
VS 46/13	●	30	40	255.0	222.0	209.5	196.5	185.0	172.0	158.0	146.0	135.5	122.0	104.0
VS 46/14	●	30	40	273.0	237.0	224.0	210.0	198.0	184.0	169.0	156.0	144.5	130.0	111.0
VS 46/15	●	37	50	293.5	255.0	241.5	226.0	213.0	198.0	182.0	168.0	156.0	140.5	120.0
VS 46/16	●	37	50	312.0	281.0	256.0	240.0	226.0	209.5	193.0	178.0	165.0	148.5	126.5
VS 46/17	●	37	50	330.0	286.0	270.0	253.5	238.5	221.0	203.5	188.0	173.5	156.0	132.5
VS 46/18		37	50	348.0	301.0	284.5	266.5	251.0	232.5	214.0	197.5	182.0	164.0	138.5
VS 46/19		45	60	372.0	323.0	305.5	286.5	270.0	250.5	230.5	212.5	197.0	177.5	152.0
VS 46/20		45	60	390.0	339.0	320.0	300.0	283.0	262.0	241.0	222.5	206.0	185.5	158.0
VS 46/21		45	60	408.5	354.0	334.5	313.5	295.5	274.0	252.0	232.5	215.0	193.5	164.5
VS 46/22		45	60	426.5	369.0	349.0	327.0	308.0	285.0	262.5	242.0	224.0	201.5	170.5
VS 46/23 HP		55	75	459.5	402.5	381.0	357.5	337.0	314.0	289.0	266.5	248.5	224.5	195.0
VS 46/24 HP		55	75	479.0	419.0	396.5	372.0	351.0	327.0	301.0	277.5	258.5	233.5	202.5
VS 46/25 HP		55	75	498.0	436.0	412.0	387.0	364.5	340.0	312.5	288.0	268.5	242.5	210.0
VS 46/26 HP		55	75	517.0	452.0	428.0	401.5	378.5	352.5	324.0	299.0	278.5	252.0	217.5

● = Pump available in R version (AISI 904L)

VS 65

Pump model	R vers.	RATED POWER		Q = DELIVERY												
				m ³ /h 0	40	45	50	55	60	65	70	75	80	85	90	100
		[kW]	[HP]	l/min 0	666.6	750	833.3	916.6	1000	1083.3	1166.6	1250	1333.3	1416.6	1500	1666.6
H = TOTAL HEAD METERS COLUMN OF WATER [m]																
VS 65/2	●	5.5	7.5	39.5	32.5	30.0	28.0	26.0	25.0	24.0	23.0	22.5	21.0	19.0	16.5	11.0
VS 65/3	●	9.3	12.5	59.5	49.5	45.5	42.0	39.0	37.5	37.0	35.0	34.0	32.0	29.0	25.0	17.0
VS 65/4	●	11	15	79.0	65.0	60.0	55.5	51.5	49.5	48.5	46.0	45.0	41.5	38.0	32.5	21.5
VS 65/5	●	15	20	98.0	81.0	75.5	71.0	66.5	64.0	61.0	58.5	56.0	52.0	46.5	41.0	28.0
VS 65/6	●	15	20	116.0	95.5	89.0	83.5	78.5	75.0	72.0	69.0	66.0	61.0	54.5	48.0	31.5
VS 65/7	●	18.5	25	136.0	112.0	105.0	98.0	92.0	88.5	85.0	81.0	77.5	72.0	64.0	56.5	37.5
VS 65/8	●	22	30	155.0	128.0	119.0	111.5	105.0	100.5	96.5	92.0	88.0	81.5	73.0	64.0	42.5
VS 65/9	●	30	40	177.5	148.0	138.0	129.0	121.5	116.0	111.5	107.0	102.0	95.5	86.0	76.0	52.5
VS 65/10	●	30	40	196.5	163.0	152.0	142.0	133.5	128.0	123.0	117.5	112.5	105.0	94.0	83.0	56.5
VS 65/11	●	30	40	215.0	177.5	165.5	155.0	146.0	140.0	134.0	128.0	122.5	114.0	102.0	90.0	60.5
VS 65/12	●	37	50	235.0	194.0	181.0	169.5	159.5	153.0	147.0	140.0	134.0	124.5	112.0	98.5	66.5
VS 65/13	●	37	50	253.0	209.0	195.0	182.5	141.5	164.5	157.5	151.0	144.0	133.5	119.5	105.0	70.5
VS 65/14	●	37	50	271.5	223.0	208.0	195.0	183.0	176.0	168.5	161.0	153.5	142.0	127.0	112.0	74.0
VS 65/15		45	60	293.5	243.0	226.5	212.0	199.5	191.0	183.5	175.5	167.5	156.0	140.0	123.5	83.5
VS 65/16		45	60	312.0	257.5	240.0	225.0	211.5	203.0	194.5	186.0	177.5	165.0	148.0	130.0	87.5
VS 65/17		45	60	330.5	272.0	254.0	237.5	223.0	214.0	205.5	196.5	187.5	173.5	155.5	137.0	91.0
VS 65/18		45	60	348.5	286.5	267.0	250.0	235.0	225.5	216.0	206.5	197.0	182.0	163.0	143.0	94.0
VS 65/19 HP		55	75	978.0	916.0	295.0	276.0	260.0	248.5	239.0	228.5	219.0	205.5	185.0	164.0	116.0
VS 65/20 HP		55	75	397.0	332.0	310.0	290.0	273.0	261.0	251.0	240.0	230.0	215.5	194.0	142.0	121.0
VS 65/21 HP		55	75	416.0	347.5	324.0	303.5	285.5	273.0	263.0	251.0	240.5	225.5	203.0	179.0	126.0

● = Pump available in R version (AISI 904L)

VS 14 - TECHNICAL DATA 60 HZ

PUMPS WITH ENCAPSULATED MOTOR

Pump model	Motor			Dimensions [mm]					Pump weight [kg]
	Type	[kW]	[HP]	L1	L2	Lt	D		
							1 cable	2 cable	
VS 14/5	E4	3.7	5	413.5	520	933.5	142.5	-	30.5
VS 14/6		5.5	7.5	443.5	652.5	1096	142.5	-	39.5
VS 14/7		5.5	7.5	473.5	652.5	1126	142.5	-	39.5
VS 14/8		5.5	7.5	503.5	652.5	1156	142.5	-	40.5
VS 14/9		7.5	10	533.5	730.5	1264	142.5	-	45
VS 14/10		7.5	10	563.5	730.5	1294	142.5	-	45.5
VS 14/11		7.5	10	593.5	730.5	1324	142.5	-	46.5

* Kit 14251005 necessary for 4" motors

VS 14/5	E6	4	5.5	411	581	992	143	144.5	49
VS 14/6		5.5	7.5	441	614.5	1055.5	143	144.5	53.5
VS 14/7		5.5	7.5	471	614.5	1085.5	143	144.5	54
VS 14/8		5.5	7.5	501	614.5	1115.5	143	144.5	55
VS 14/9		7.5	10	531	646	1177	143	144.5	59.5
VS 14/10		7.5	10	561	646	1207	143	144.5	60
VS 14/11		7.5	10	591	646	1237	143	144.5	61
VS 14/12		9.3	12.5	621	678.5	1299.5	143	144.5	64.5
VS 14/13		9.3	12.5	651	678.5	1329.5	143	144.5	65
VS 14/14		11	15	681	711	1392	143	144.5	69.5
VS 14/15		11	15	711	711	1422	143	144.5	70
VS 14/16		11	15	741	711	1452	143	144.5	71
VS 14/17		11	15	771	711	1482	143	144.5	71.5
VS 14/18		15	20	801	776	1577	143	144.5	78
VS 14/19		15	20	831	776	1607	143	144.5	78.5
VS 14/20		15	20	861	776	1637	143	144.5	79.5
VS 14/21		15	20	891	776	1667	143	144.5	80
VS 14/22		15	20	921	776	1697	143	144.5	80.5

PUMPS WITH REWINDABLE MOTOR

Pump model	Motor			Dimensions [mm]					Pump weight [kg]
	Type	[kW]	[HP]	L1	L2	Lt	D		
							1 cable	2 cable	
VS 14/5	RW6	4	5.5	411	699	1110	147	147.5	59.5
VS 14/6		5.5	7.5	441	699	1140	147	147.5	60.5
VS 14/7		5.5	7.5	471	699	1170	147	147.5	61
VS 14/8		5.5	7.5	501	699	1200	147	147.5	62
VS 14/9		7.5	10	531	719	1250	147	147.5	64.5
VS 14/10		7.5	10	561	719	1280	147	147.5	65
VS 14/11		7.5	10	591	719	1310	147	147.5	66
VS 14/12		9.3	12.5	621	749	1370	147	147.5	70
VS 14/13		9.3	12.5	651	749	1400	147	147.5	70.5
VS 14/14		11	15	681	779	1460	147	147.5	74.5
VS 14/15		11	15	711	779	1490	147	147.5	75
VS 14/16		11	15	741	779	1520	147	147.5	76
VS 14/17		11	15	771	779	1550	147	147.5	76.5
VS 14/18		13	17.5	801	829	1630	147	147.5	82.5
VS 14/19		13	17.5	831	829	1660	147	147.5	83
VS 14/20		15	20	861	874	1735	147	147.5	89
VS 14/21		15	20	891	874	1765	147	147.5	89.5
VS 14/22		15	20	921	874	1795	147	147.5	90

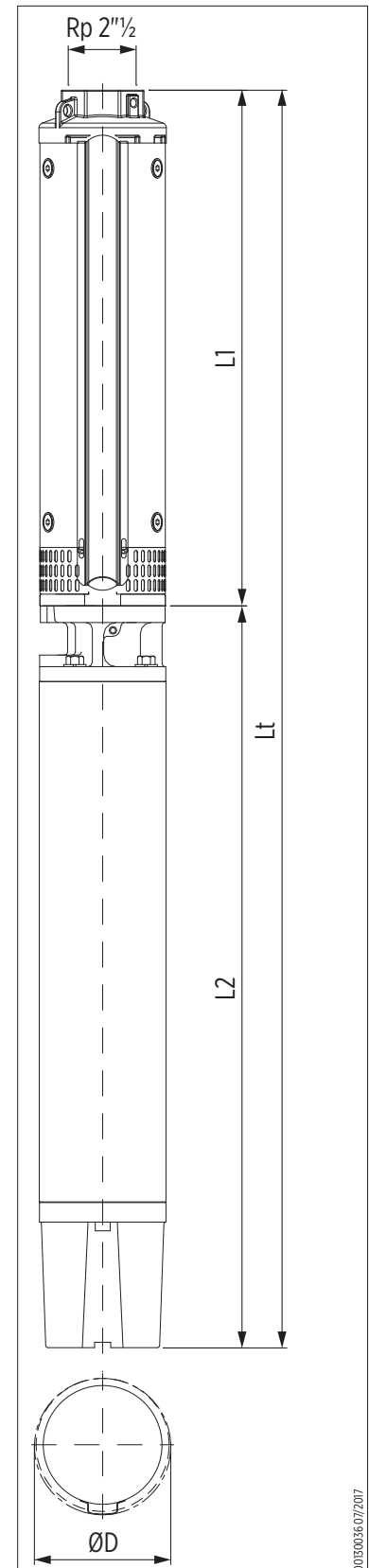

0030036/07/07

VS 14 - PERFORMANCE CURVES 60 HZ

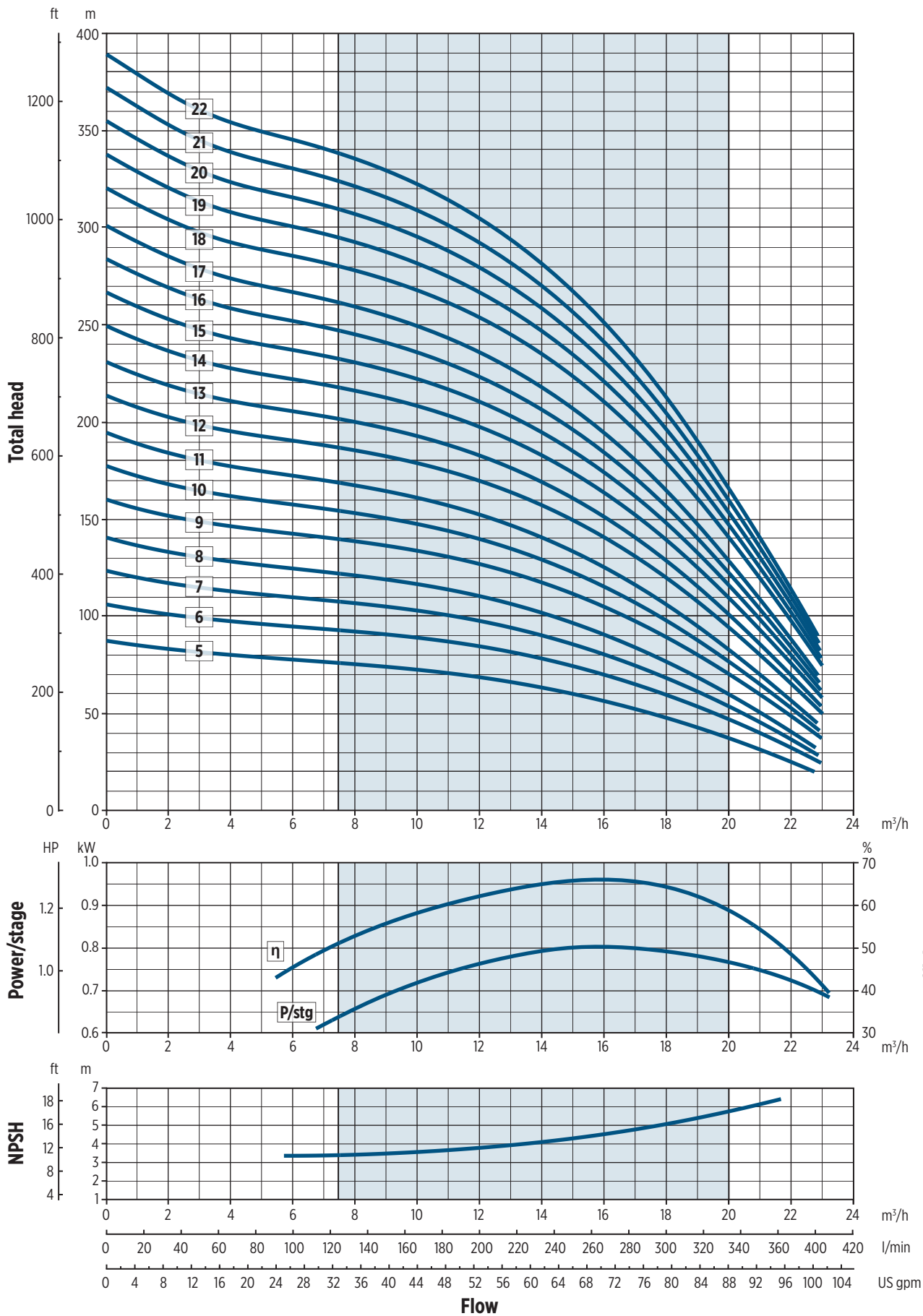

00T0155EN 09/2018

VS 14 - TECHNICAL DATA 60 HZ

PUMPS WITH ENCAPSULATED MOTOR

Pump model	Motor			Dimensions [mm]					Pump weight [kg]
	Type	[kW]	[HP]	L1	L2	Lt	D		
							1 cable	2 cable	
VS 14/23	E6	18.5	25	951	841.5	1792.5	143	144.5	88.5
VS 14/24		18.5	25	981	841.5	1822.5	143	144.5	89
VS 14/25		18.5	25	1011	841.5	1852.5	143	144.5	90
VS 14/26		18.5	25	1041	841.5	1882.5	143	144.5	90.5
VS 14/27		18.5	25	1071	841.5	1912.5	143	144.5	92.5
VS 14/28		18.5	25	1101	841.5	1942.5	143	144.5	92.5
VS 14/29		22	30	1131	906.5	2037.5	143	144.5	100
VS 14/30		22	30	1161	906.5	2067.5	143	144.5	100.5
VS 14/31		22	30	1191	906.5	2097.5	143	144.5	100.5
VS 14/32		22	30	1220.5	906.5	2127	143	144.5	101

PUMPS WITH REWINDABLE MOTOR

Pump model	Motor			Dimensions [mm]					Pump weight [kg]
	Type	[kW]	[HP]	L1	L2	Lt	D		
							1 cable	2 cable	
VS 14/23	RW6	18.5	25	951	919	1870	147	147.5	95
VS 14/24		18.5	25	981	919	1900	147	147.5	95.5
VS 14/25		18.5	25	1011	919	1930	147	147.5	96.5
VS 14/26		18.5	25	1041	919	1960	147	147.5	97
VS 14/27		18.5	25	1071	919	1990	147	147.5	99
VS 14/28		18.5	25	1101	919	2020	147	147.5	99
VS 14/29		22	30	1131	1009	2140	147	147.5	109.5
VS 14/30		22	30	1161	1009	2170	147	147.5	110
VS 14/31		22	30	1191	1009	2200	147	147.5	110
VS 14/32		22	30	1220.5	1009	2229.5	147	147.5	110.5

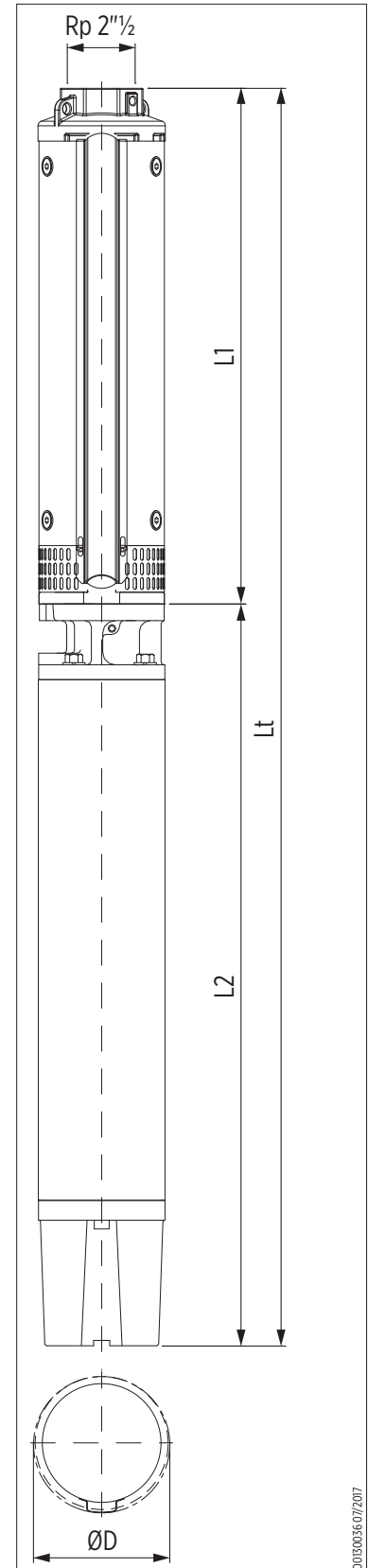

0030036 017207

VS 14 - PERFORMANCE CURVES 60 HZ

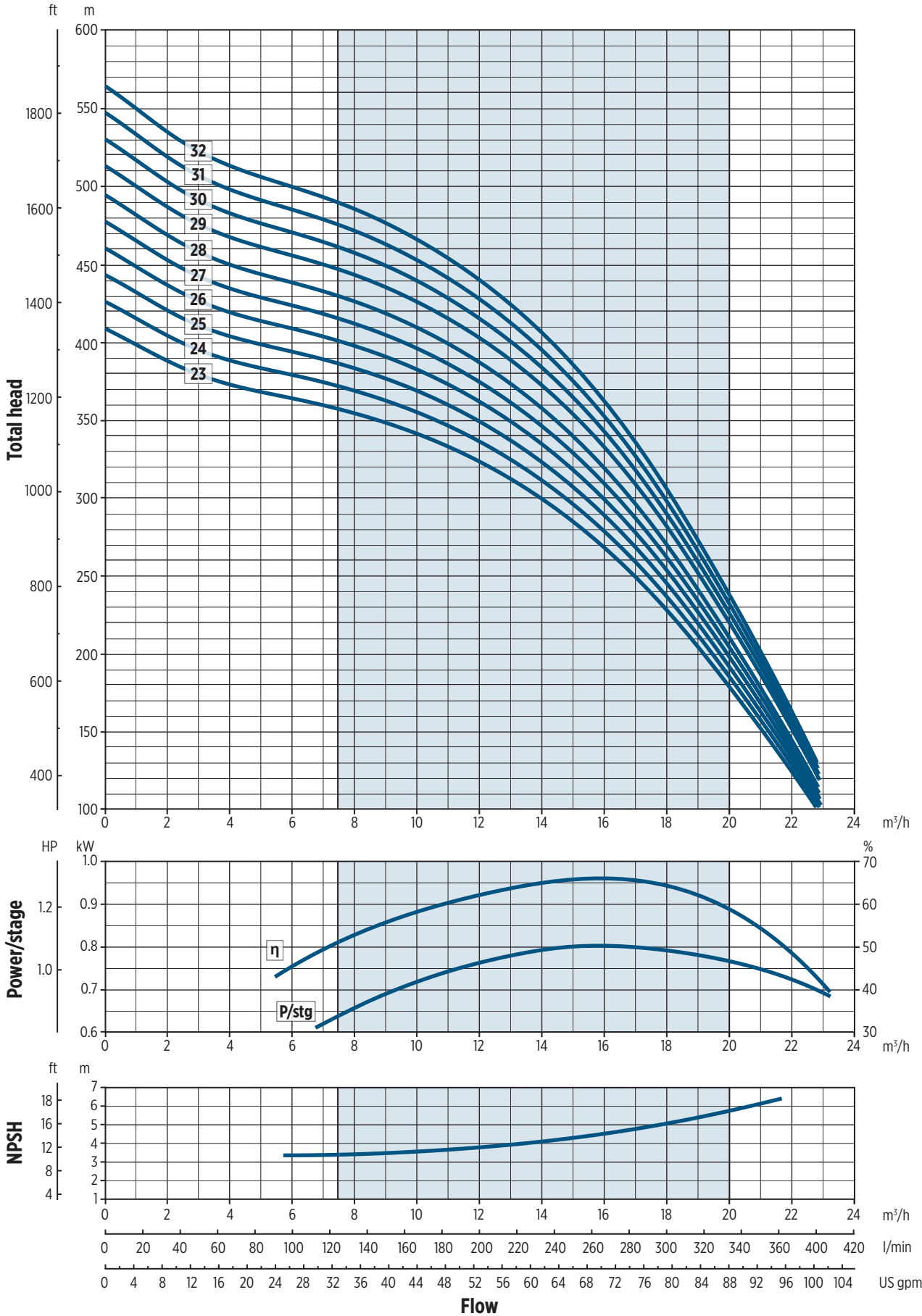

VS 14 HIGH PRESSURE - TECHNICAL DATA 60 HZ

PUMPS WITH ENCAPSULATED MOTOR

Pump model	Motor			Dimensions [mm]					Pump weight [kg]
	Type	[kW]	[HP]	L1	L2	Lt	D		
							1 cable	2 cable	
VS 14/33 HP	E6	30	40	1250.5	1036.5	2287	145	146.5	116.5
VS 14/34 HP		30	40	1280.5	1036.5	2317	145	146.5	117.5
VS 14/35 HP		30	40	1310.5	1036.5	2347	145	146.5	118
VS 14/36 HP		30	40	1340.5	1036.5	2377	145	146.5	118.5
VS 14/37 HP		30	40	1370.5	1036.5	2407	145	146.5	119.5
VS 14/38 HP		30	40	1400.5	1036.5	2437	145	146.5	120
VS 14/39 HP		30	40	1430.5	1036.5	2467	145	146.5	121.5
VS 14/40 HP		30	40	1460.5	1036.5	2497	145	146.5	122.5
VS 14/41 HP		30	40	1490.5	1036.5	2527	145	146.5	123
VS 14/42 HP		30	40	1520.5	1036.5	2557	145	146.5	123

PUMPS WITH REWINDABLE MOTOR

Pump model	Motor			Dimensions [mm]					Pump weight [kg]
	Type	[kW]	[HP]	L1	L2	Lt	D		
							1 cable	2 cable	
VS 14/33 HP	RW6	26	35	1250.5	1114	2364.5	149	149.5	122.5
VS 14/34 HP		26	35	1280.5	1114	2394.5	149	149.5	123.5
VS 14/35 HP		26	35	1310.5	1114	2424.5	149	149.5	124
VS 14/36 HP		26	35	1340.5	1114	2454.5	149	149.5	124.5
VS 14/37 HP		26	35	1370.5	1114	2484.5	149	149.5	125.5
VS 14/38 HP		26	35	1400.5	1114	2514.5	149	149.5	126
VS 14/39 HP		26	35	1430.5	1114	2544.5	149	149.5	127.5
VS 14/40 HP		30	40	1460.5	1214	2674.5	149	149.5	138.5
VS 14/41 HP		30	40	1490.5	1214	2704.5	149	149.5	139
VS 14/42 HP		30	40	1520.5	1214	2734.5	149	149.5	139

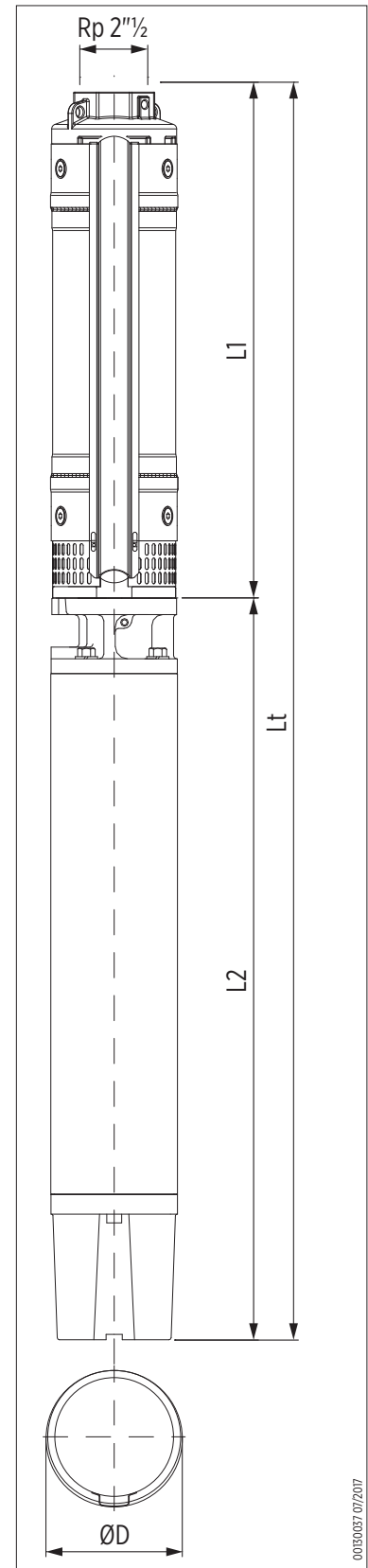

00180057 01/2017

VS 14 HIGH PRESSURE- PERFORMANCE CURVES 60 HZ

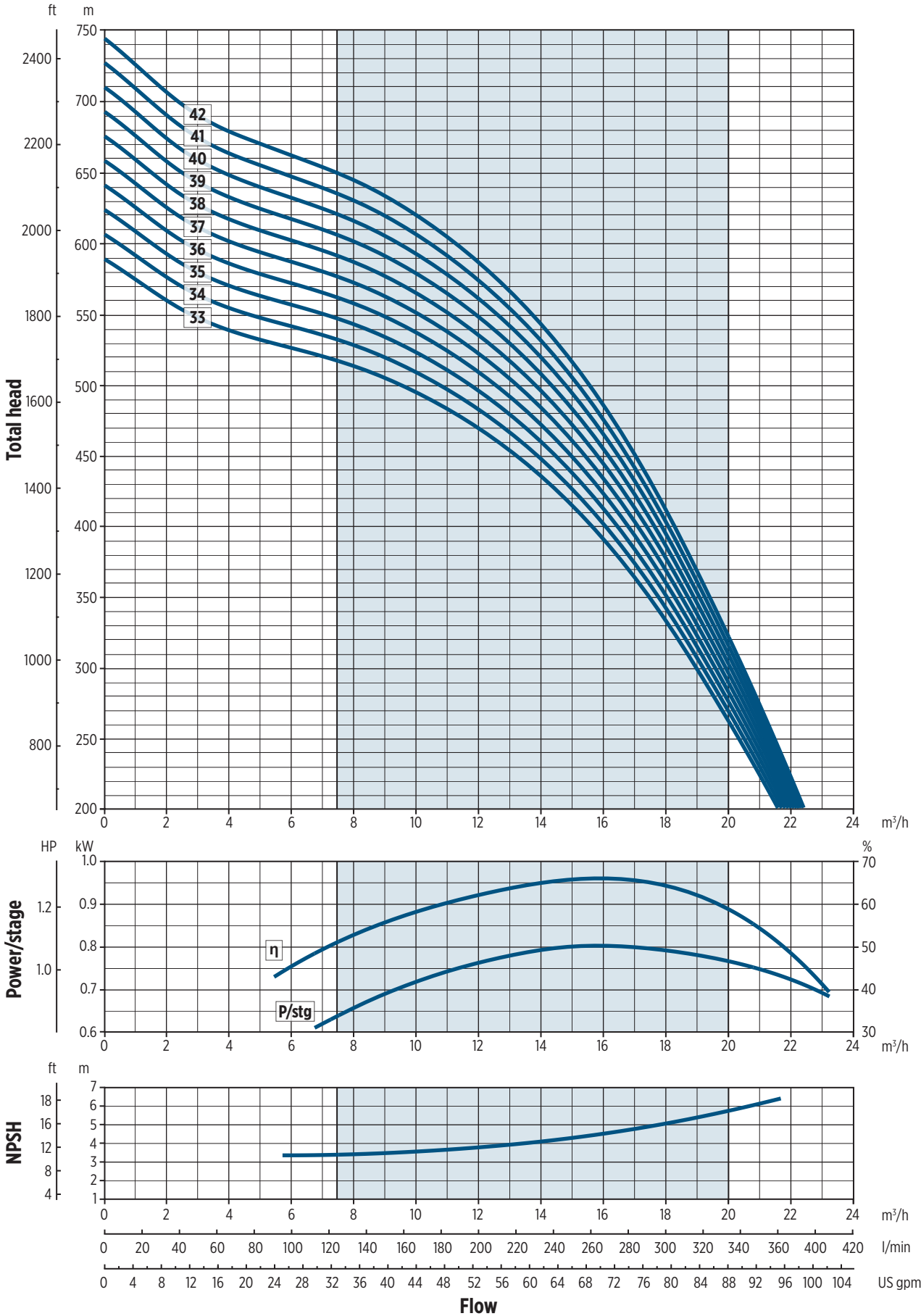

VS 19 - TECHNICAL DATA 60 HZ

PUMPS WITH ENCAPSULATED MOTOR

Pump model	Type	Motor		Dimensions [mm]					Pump weight [kg]
		[kW]	[HP]	L1	L2	Lt	D		
							1 cable	2 cable	
VS 19/3	E4	3	4	385	477	862	142.5	-	27
VS 19/4		5.5	7.5	422.5	652.5	1075	142.5	-	38
VS 19/5		5.5	7.5	460	652.5	1112.5	142.5	-	39
VS 19/6		7.5	10	497.5	730.5	1228	142.5	-	43
VS 19/7		7.5	10	535	730.5	1265.5	142.5	-	44

* Kit 14251005 necessary for 4" motors

VS 19/3	E6	4	5.5	382.5	581	581	143	144.5	48
VS 19/4		5.5	7.5	420	614.5	614.5	143	144.5	52
VS 19/5		5.5	7.5	457.5	614.5	614.5	143	144.5	53
VS 19/6		7.5	10	495	646	1141	143	144.5	57.5
VS 19/7		7.5	10	532.5	646	1178.5	143	144.5	58.5
VS 19/8		9.3	12.5	570	678.5	1248.5	143	144.5	62
VS 19/9		9.3	12.5	607.5	678.5	1286	143	144.5	62.5
VS 19/10		11	15	645	711	1356	143	144.5	67
VS 19/11		11	15	682.5	711	1393.5	143	144.5	68
VS 19/12		15	20	720	776	1496	143	144.5	74
VS 19/13		15	20	757.5	776	1533.5	143	144.5	75
VS 19/14		15	20	795	776	1571	143	144.5	76
VS 19/15		15	20	832.5	776	1608.5	143	144.5	76.5
VS 19/16		18.5	25	870	841.5	1711.5	143	144.5	84.5
VS 19/17		18.5	25	907.5	841.5	1749	143	144.5	85.5
VS 19/18		18.5	25	945	841.5	1786.5	143	144.5	86
VS 19/19		22	30	982.5	906.5	1889	143	144.5	93
VS 19/20		22	30	1020	906.5	1926.5	143	144.5	93.5
VS 19/21		22	30	1057.5	906.5	1964	143	144.5	94.5
VS 19/22		22	30	1095	906.5	2001.5	143	144.5	95.5
VS 19/23		30	40	1132.5	1036.5	2169	143	144.5	110.5
VS 19/24		30	40	1170	1036.5	2206.5	143	144.5	111.5
VS 19/25		30	40	1207.5	1036.5	2244	143	144.5	112.5
VS 19/26		30	40	1245	1036.5	2281.5	143	144.5	113
VS 19/27		30	40	1282.5	1036.5	2319	143	144.5	115
VS 19/28		30	40	1319.5	1036.5	2356	143	144.5	115
VS 19/29		30	40	1357	1036.5	2393.5	143	144.5	115.5
VS 19/30		30	40	1394.5	1036.5	2431	143	144.5	116.5

PUMPS WITH REWINDABLE MOTOR

Pump model	Type	Motor		Dimensions [mm]					Pump weight [kg]
		[kW]	[HP]	L1	L2	Lt	D		
							1 cable	2 cable	
VS 19/3	RW6	4	5.5	382.5	699	1081.5	147	147.5	58
VS 19/4		5.5	7.5	420	699	1119	147	147.5	59
VS 19/5		5.5	7.5	457.5	699	1156.5	147	147.5	60
VS 19/6		7.5	10	495	719	1214	147	147.5	62.5
VS 19/7		7.5	10	532.5	719	1251.5	147	147.5	63.5
VS 19/8		9.3	12.5	570	749	1319	147	147.5	67.5
VS 19/9		9.3	12.5	607.5	749	1356.5	147	147.5	68
VS 19/10		11	15	645	779	1424	147	147.5	72
VS 19/11		11	15	682.5	779	1461.5	147	147.5	73
VS 19/12		13	17.5	720	829	1549	147	147.5	78.5
VS 19/13		13	17.5	757.5	829	1586.5	147	147.5	79.5
VS 19/14		15	20	795	874	1669	147	147.5	85.5
VS 19/15		15	20	832.5	874	1706.5	147	147.5	86
VS 19/16		18.5	25	870	919	1789	147	147.5	91
VS 19/17		18.5	25	907.5	919	1826.5	147	147.5	92
VS 19/18		18.5	25	945	919	1864	147	147.5	92.5
VS 19/19		22	30	982.5	1009	1991.5	147	147.5	102.5
VS 19/20		22	30	1020	1009	2029	147	147.5	103
VS 19/21		22	30	1057.5	1009	2066.5	147	147.5	104
VS 19/22		22	30	1095	1009	2104	147	147.5	105
VS 19/23		26	35	1132.5	1114	2246.5	147	147.5	116.5
VS 19/24		26	35	1170	1114	2284	147	147.5	117.5
VS 19/25		26	35	1207.5	1114	2321.5	147	147.5	118.5
VS 19/26		26	35	1245	1114	2359	147	147.5	119
VS 19/27		30	40	1282.5	1214	2496.5	147	147.5	131
VS 19/28		30	40	1319.5	1214	2533.5	147	147.5	131
VS 19/29		30	40	1357	1214	2571	147	147.5	131.5
VS 19/30		30	40	1394.5	1214	2608.5	147	147.5	132.5

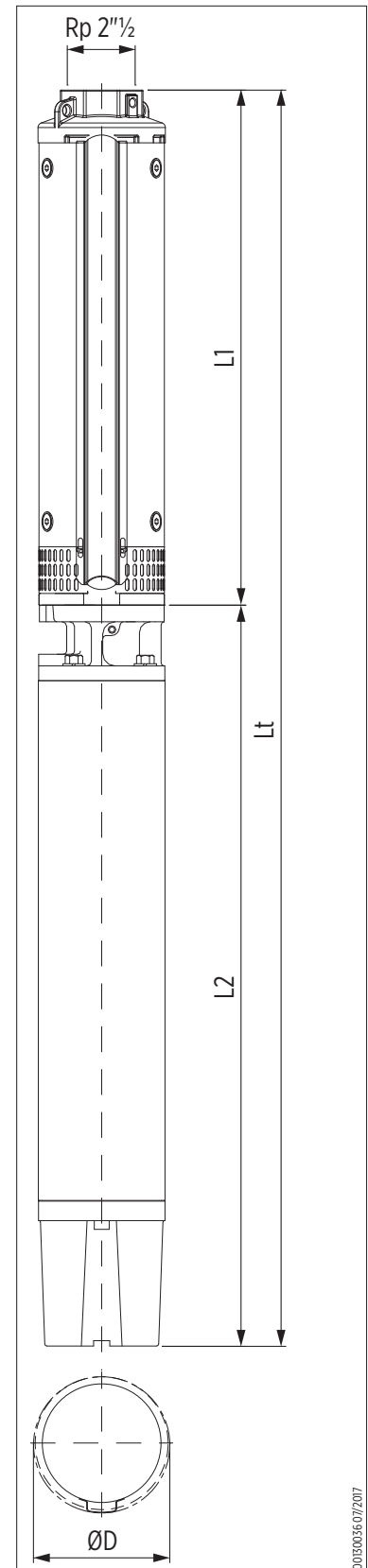

0030036 01707

VS 19 - PERFORMANCE CURVES 60 HZ

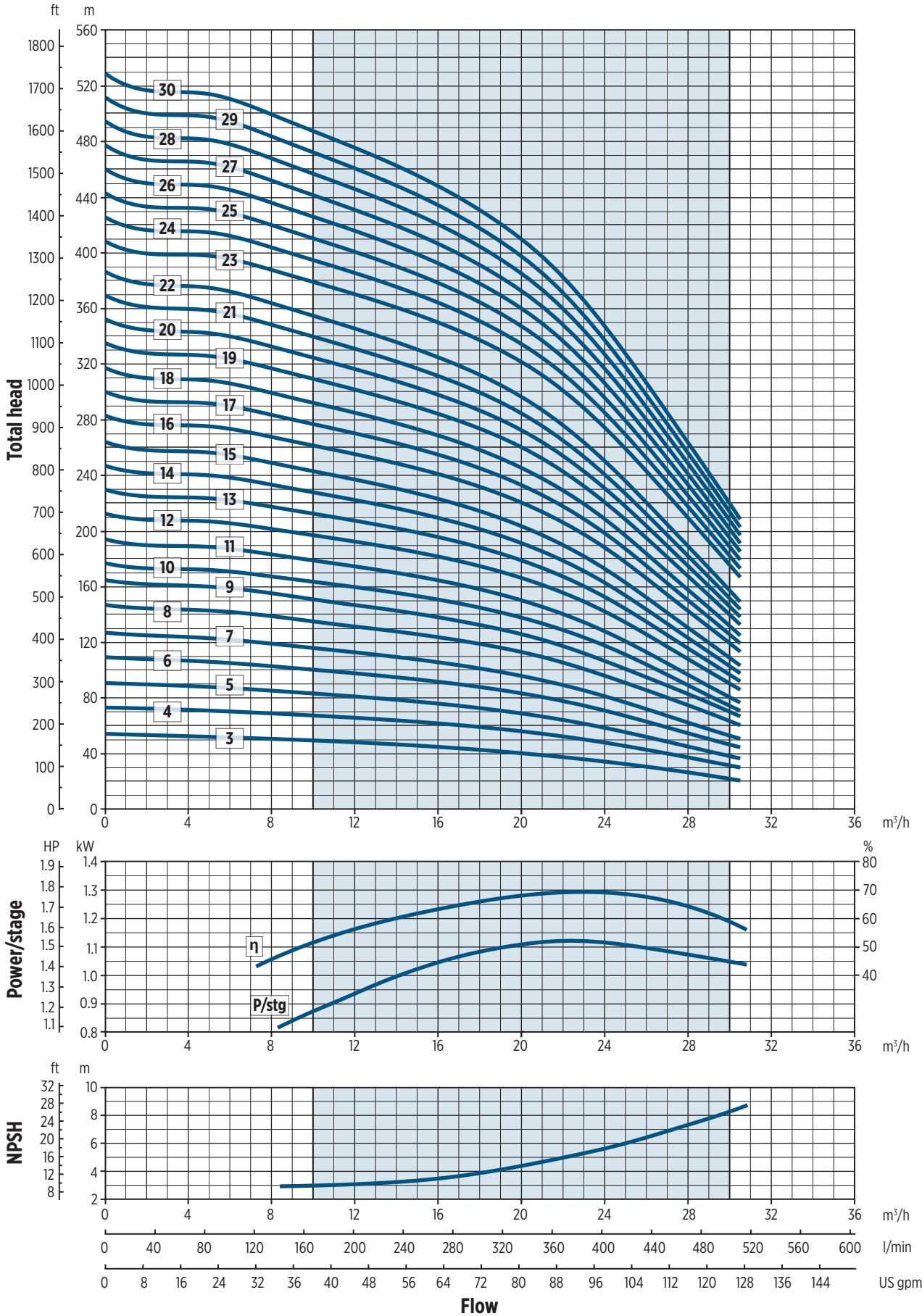

VS 19 HIGH PRESSURE - TECHNICAL DATA 60 HZ

PUMPS WITH ENCAPSULATED MOTOR

Pump model	Motor			Dimensions [mm]					Pump weight [kg]
	Type	[kW]	[HP]	L1	L2	Lt	D		
							1 cable	2 cable	
VS 19/31 HP	E6	37	50	1432	1421.5	2853.5	145	146.5	171.5
VS 19/32 HP		37	50	1469.5	1421.5	2891	145	146.5	172
VS 19/33 HP		37	50	1507	1421.5	2928.5	145	146.5	173
VS 19/34 HP		37	50	1544.5	1421.5	2966	145	146.5	173.5
VS 19/35 HP		37	50	1582	1421.5	3003.5	145	146.5	174.5
VS 19/36 HP		37	50	1619.5	1421.5	3041	145	146.5	175
VS 19/37 HP		45	60	1657	1574	3231	145	146.5	190.5
VS 19/38 HP		45	60	1694.5	1574	3268.5	145	146.5	192
VS 19/39 HP		45	60	1732	1574	3306	145	146.5	192
VS 19/40 HP		45	60	1769.5	1574	3343.5	145	146.5	192.5
VS 19/41 HP		45	60	1807	1574	3381	145	146.5	194
VS 19/42 HP		45	60	1844.5	1574	3418.5	145	146.5	195

PUMPS WITH REWINDABLE MOTOR

Pump model	Motor			Dimensions [mm]					Pump weight [kg]
	Type	[kW]	[HP]	L1	L2	Lt	D		
							1 cable	2 cable	
VS 19/31 HP	RW6	37	50	1432	1294	2726	149	149.5	140.5
VS 19/32 HP		37	50	1469.5	1294	2763.5	149	149.5	141
VS 19/33 HP		37	50	1507	1294	2801	149	149.5	142
VS 19/34 HP		37	50	1544.5	1294	2838.5	149	149.5	142.5
VS 19/35 HP		37	50	1582	1294	2876	149	149.5	143.5
VS 19/36 HP		37	50	1619.5	1294	2913.5	149	149.5	144

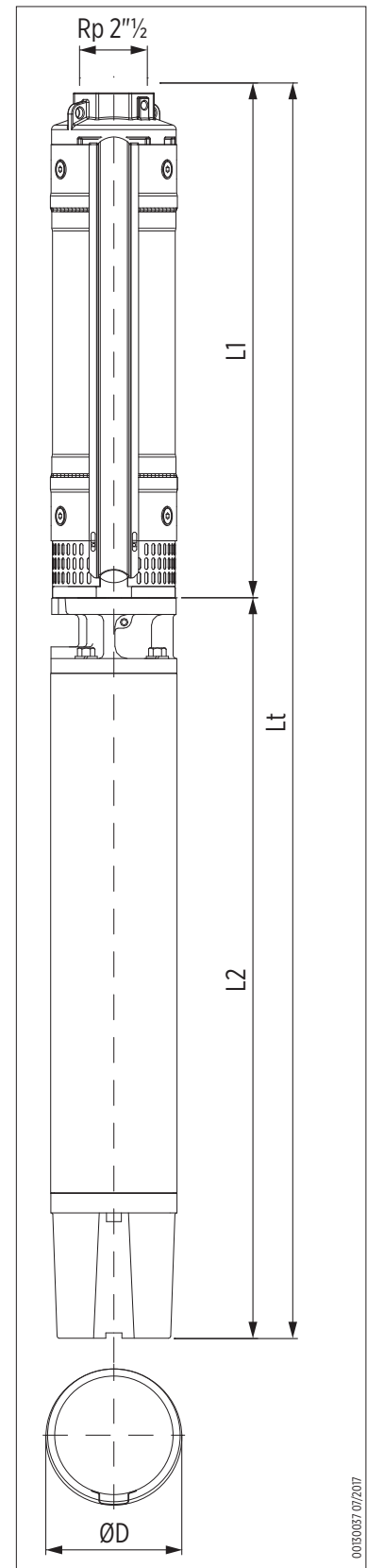

0010057_07/2017

VS 19 HIGH PRESSURE- PERFORMANCE CURVES 60 HZ

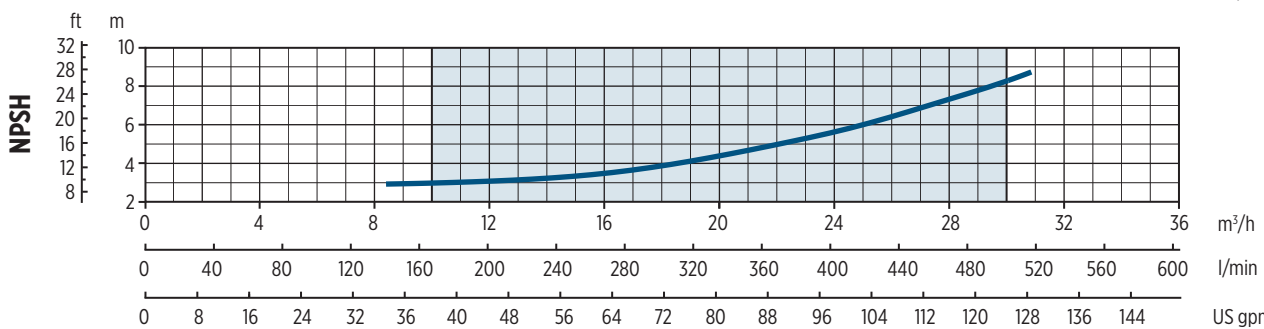
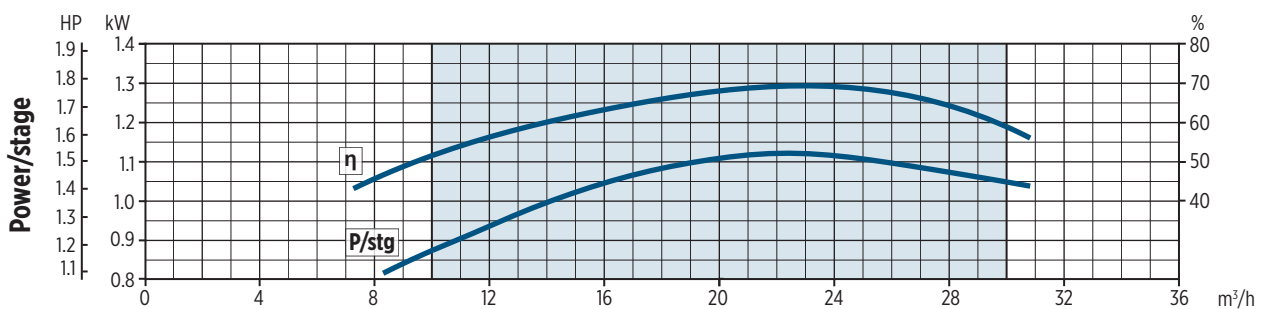
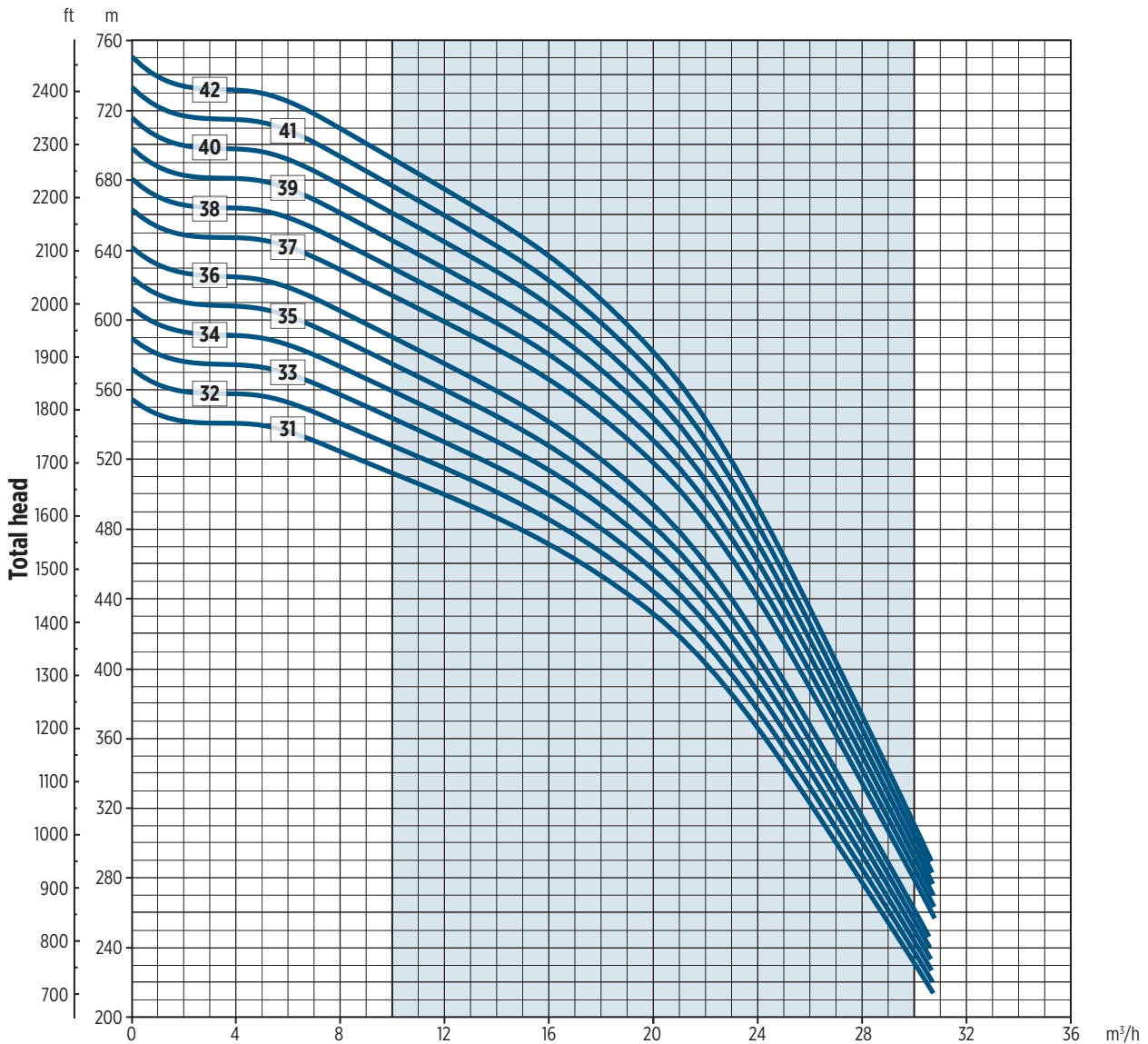

The hydraulic characteristics are guaranteed, according to ISO standard 9906:2012, grade 3B

VS 25* - TECHNICAL DATA 60 HZ

* IMPORTANT: Models only for sales out of EU or as a component of fire-fighting units

PUMPS WITH ENCAPSULATED MOTOR

Pump model	Motor			Dimensions [mm]					Pump weight [kg]
	Type	[kW]	[HP]	L1	L2	Lt	D		
							1 cable	2 cable	
VS 25/3	E4	5.5	7.5	461	652.5	1113.5	142.5	-	38
VS 25/4		7.5	10	507.5	730.5	1238	142.5	-	43

* Kit 14251005 necessary for 4" motors

Pump model	Type	[kW]	[HP]	L1	L2	Lt	1 cable	2 cable	Pump weight [kg]
VS 25/3	E6	5.5	7.5	458.5	614.5	1073	143	144.5	52.5
VS 25/4		7.5	10	505	646	1151	143	144.5	57.5
VS 25/5		9.3	12.5	551.5	678.5	1230	143	144.5	61
VS 25/6		11	15	598	711	1309	143	144.5	65.5
VS 25/7		11	15	644.5	711	1355.5	143	144.5	66.5
VS 25/8		15	20	691	776	1467	143	144.5	73
VS 25/9		15	20	737.5	776	1513.5	143	144.5	74
VS 25/10		18.5	25	784	841.5	1625.5	143	144.5	82.5
VS 25/11		18.5	25	830.5	841.5	1672	143	144.5	83
VS 25/12		22	30	877	906.5	1783.5	143	144.5	90.5
VS 25/13		22	30	923.5	906.5	1830	143	144.5	92
VS 25/14		22	30	970	906.5	1876.5	143	144.5	92
VS 25/15		30	40	1016.5	1036.5	2053	143	144.5	107
VS 25/16		30	40	1063	1036.5	2099.5	143	144.5	108.5
VS 25/17		30	40	1109.5	1036.5	2146	143	144.5	109
VS 25/18		30	40	1156	1036.5	2192.5	143	144.5	110
VS 25/19		30	40	1202.5	1036.5	2239	143	144.5	111
VS 25/20		37	50	1249	1421.5	2670.5	143	144.5	166
VS 25/21		37	50	1295.5	1421.5	2717	143	144.5	167
VS 25/22		37	50	1342	1421.5	2763.5	143	144.5	168
VS 25/23		37	50	1388.5	1421.5	2810	143	144.5	169

PUMPS WITH REWINDABLE MOTOR

Pump model	Motor			Dimensions [mm]					Pump weight [kg]
	Type	[kW]	[HP]	L1	L2	Lt	D		
							1 cable	2 cable	
VS 25/3	RW6	5.5	7.5	458.5	699	1157.5	147	147.5	59.5
VS 25/4		7.5	10	505	719	1224	147	147.5	62.5
VS 25/5		9.3	12.5	551.5	749	1300.5	147	147.5	66.5
VS 25/6		11	15	598	779	1377	147	147.5	70.5
VS 25/7		11	15	644.5	779	1423.5	147	147.5	71.5
VS 25/8		13	17.5	691	829	1520	147	147.5	77.5
VS 25/9		15	20	737.5	874	1611.5	147	147.5	83.5
VS 25/10		18.5	25	784	919	1703	147	147.5	89
VS 25/11		18.5	25	830.5	919	1749.5	147	147.5	89.5
VS 25/12		22	30	877	1009	1886	147	147.5	100
VS 25/13		22	30	923.5	1009	1932.5	147	147.5	101.5
VS 25/14		22	30	970	1009	1979	147	147.5	101.5
VS 25/15		26	35	1016.5	1114	2130.5	147	147.5	113
VS 25/16		26	35	1063	1114	2177	147	147.5	114.5
VS 25/17		26	35	1109.5	1114	2223.5	147	147.5	115
VS 25/18		30	40	1156	1214	2370	147	147.5	126
VS 25/19		30	40	1202.5	1214	2416.5	147	147.5	127
VS 25/20		37	50	1249	1294	2543	147	147.5	135
VS 25/21		37	50	1295.5	1294	2589.5	147	147.5	136
VS 25/22		37	50	1342	1294	2636	147	147.5	137
VS 25/23		37	50	1388.5	1294	2682.5	147	147.5	138

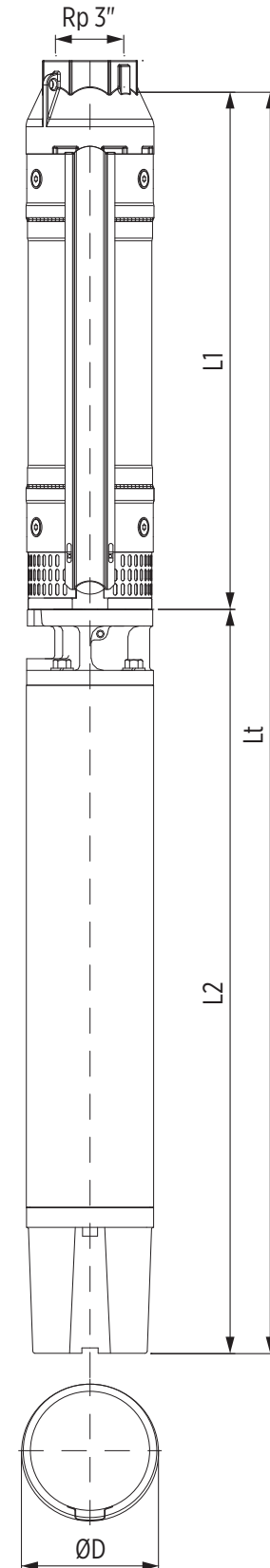

00130248 06/2021

VS 25* - PERFORMANCE CURVES 60 HZ

* IMPORTANT: Models only for sales out of EU or as a component of fire-fighting units

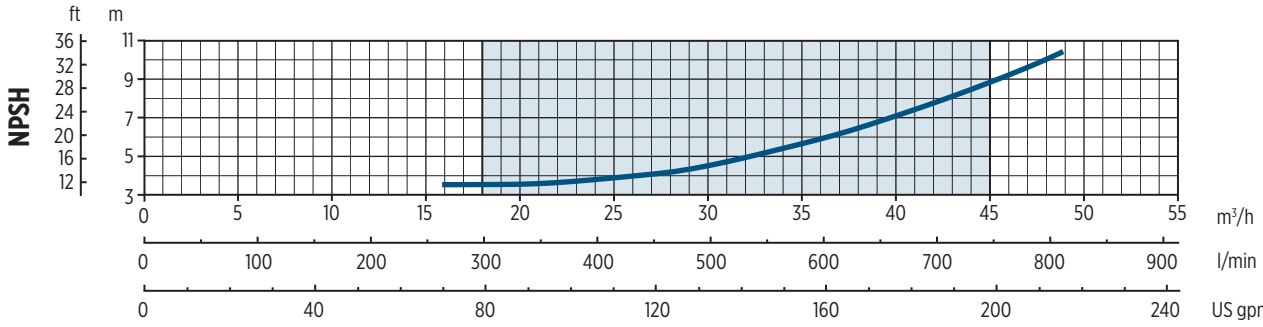
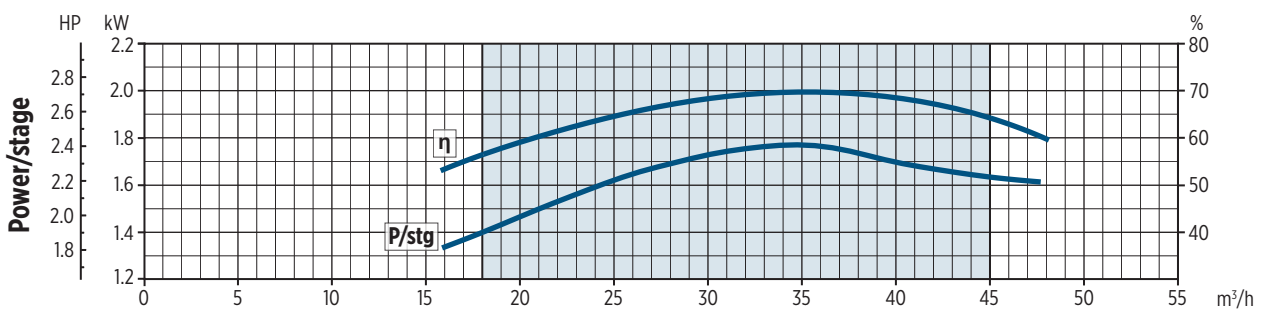
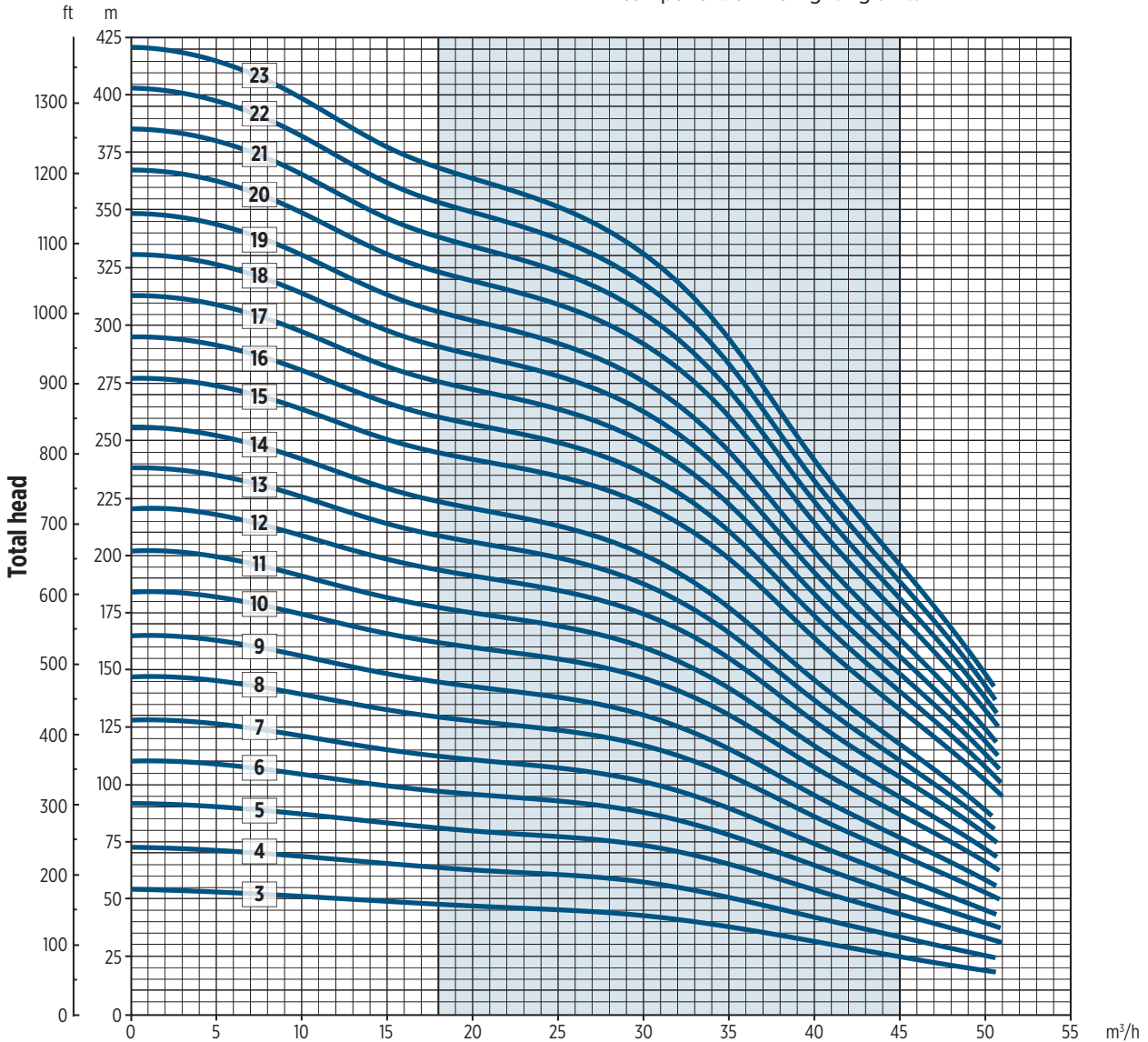

VS 25* HIGH PRESSURE - TECHNICAL DATA 60 HZ

* IMPORTANT: Models only for sales out of EU or as a component of fire-fighting units

PUMPS WITH ENCAPSULATED MOTOR

Pump model	Motor			Dimensions [mm]					Pump weight [kg]
	Type	[kW]	[HP]	L1	L2	Lt	D		
							1 cable	2 cable	
VS 25/24 HP	E6	45	60	1435	1574	3009	143	144.5	184
VS 25/25 HP		45	60	1481	1574	3055	143	144.5	185
VS 25/26 HP		45	60	1527.5	1574	3101.5	143	144.5	186
VS 25/27 HP		45	60	1574	1574	3148	143	144.5	187
VS 25/28 HP		45	60	1620.5	1574	3194.5	143	144.5	188

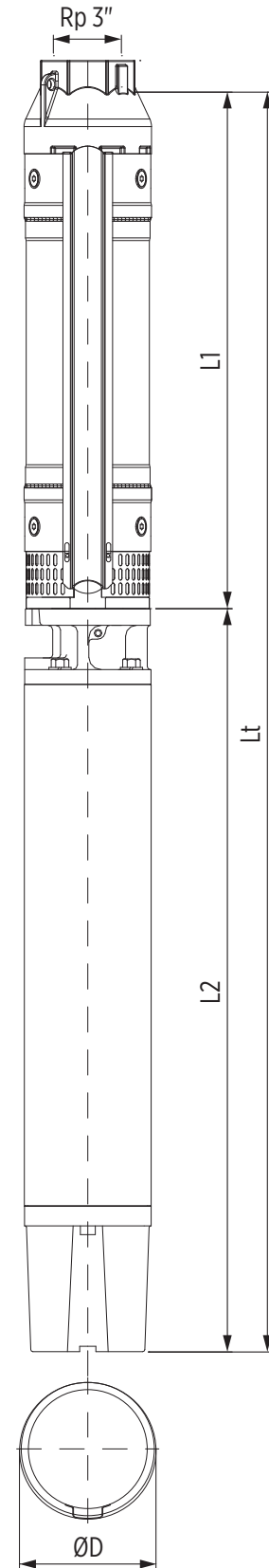

00180248 016/2021

VS 25* HIGH PRESSURE- PERFORMANCE CURVES 60 HZ

Models only for sales out of EU or as a component of fire-fighting units

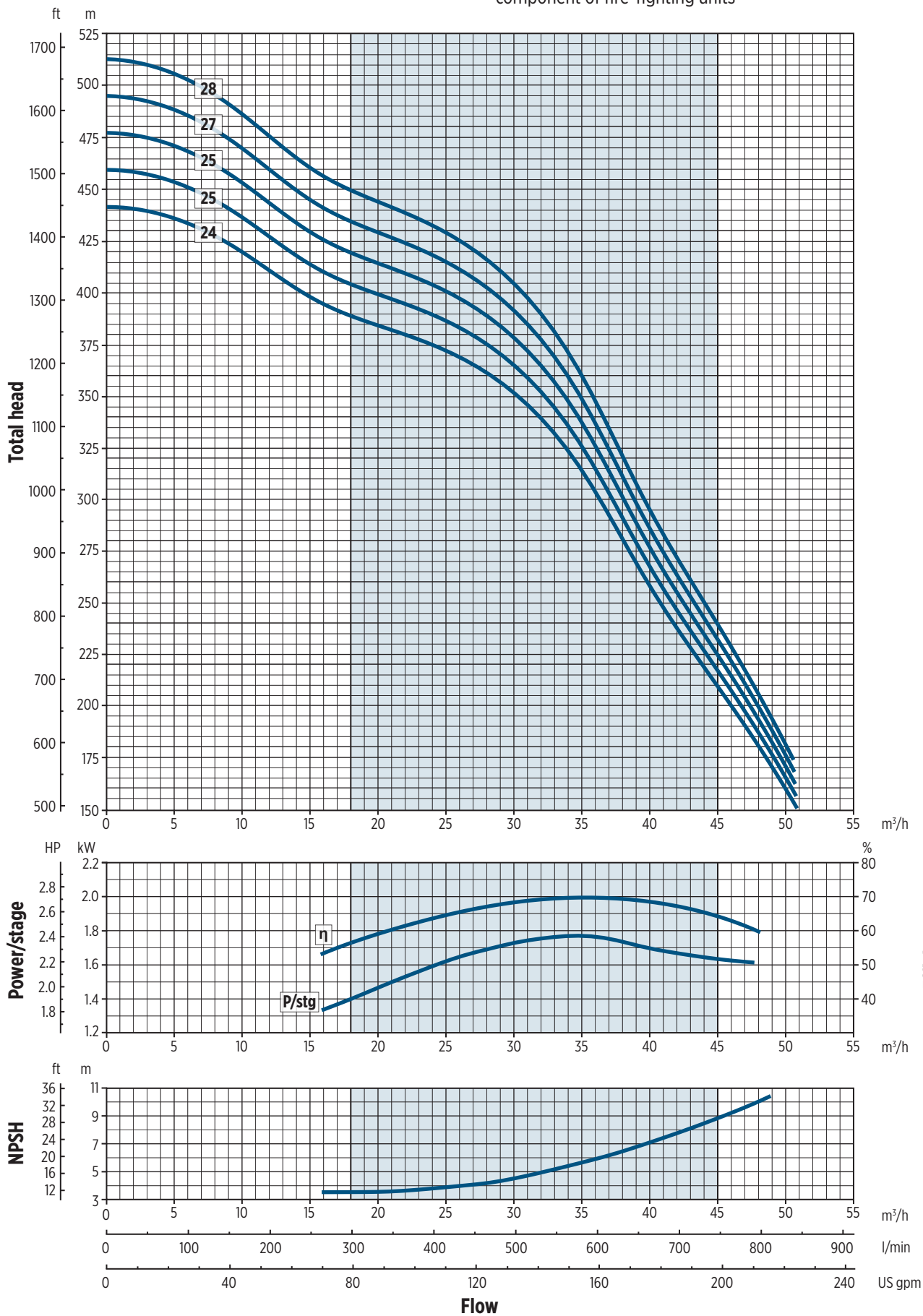

VS 30 - TECHNICAL DATA 60 HZ

PUMPS WITH ENCAPSULATED MOTOR

Pump model	Motor			Dimensions [mm]					Pump weight [kg]
	Type	[kW]	[HP]	L1	L2	Lt	D		
							1 cable	2 cable	
VS 30/3	E4	5.5	7.5	622	652.5	1274.5	142.5	-	41.5
VS 30/4		7.5	10	707.5	730.5	1438	142.5	-	47.5

* Kit 14251005 necessary for 4" motors

Pump model	Type	Motor		Dimensions [mm]					Pump weight [kg]
		[kW]	[HP]	L1	L2	Lt	D		
VS 30/3	E6	5.5	7.5	620	614.5	1234.5	143	144.5	55.5
VS 30/4		7.5	10	705.5	646	1351.5	143	144.5	62
VS 30/5		9.3	12.5	790.5	678.5	1469	143	144.5	66.5
VS 30/6		11	15	876	711	1587	143	144.5	72
VS 30/7		15	20	961.5	776	1737.5	143	144.5	79.5
VS 30/8		15	20	1047	776	1823	143	144.5	82
VS 30/9		18.5	25	1132.5	841.5	1974	143	144.5	91
VS 30/10		18.5	25	1218	841.5	2059.5	143	144.5	93
VS 30/11		22	30	1303.5	906.5	2210	143	144.5	101
VS 30/12		22	30	1389	906.5	2295.5	143	144.5	103
VS 30/13		30	40	1474.5	1036.5	2511	143	144.5	119.5
VS 30/14		30	40	1560	1036.5	2596.5	143	144.5	122
VS 30/15		30	40	1645.5	1036.5	2682	143	144.5	124
VS 30/16		30	40	1730.5	1036.5	2767	143	144.5	126
VS 30/17		37	50	1816	1421.5	3237.5	143	144.5	182
VS 30/18		37	50	1901.5	1421.5	3323	143	144.5	184
VS 30/19		37	50	1987	1421.5	3408.5	143	144.5	186
VS 30/20		37	50	2072.5	1421.5	3494	143	144.5	188.5
VS 30/21		45	60	2157.5	1574	3731.5	143	144.5	204.5
VS 30/22		45	60	2243	1574	3817	143	144.5	206.5
VS 30/23		45	60	2328.5	1574	3902.5	143	144.5	208.5
VS 30/24		45	60	2414	1574	3988	143	144.5	210.5

PUMPS WITH REWINDABLE MOTOR

Pump model	R vers.	Motor			Dimensions [mm]					Pump weight [kg]	
		Type	[kW]	[HP]	L1	L2	Lt	D			
								1 cable	2 cable		
VS 30/3	●	RW6	5.5	7.5	620	699	1319	147	147.5	62.5	
VS 30/4	●		7.5	10	705.5	719	1424.5	147	147.5	67	
VS 30/5	●		9.3	12.5	790.5	749	1539.5	147	147.5	72	
VS 30/6	●		11	15	876	779	1655	147	147.5	77	
VS 30/7	●		13	17.5	961.5	829	1790.5	147	147.5	84	
VS 30/8	●		15	20	1047	874	1921	147	147.5	91.5	
VS 30/9	●		18.5	25	1132.5	919	2051.5	147	147.5	97.5	
VS 30/10	●		18.5	25	1218	919	2137	147	147.5	99.5	
VS 30/11	●		22	30	1303.5	1009	2312.5	147	147.5	110.5	
VS 30/12	●		22	30	1389	1009	2398	147	147.5	112.5	
VS 30/13	●		26	35	1474.5	1114	2588.5	147	147.5	125.5	
VS 30/14	●		26	35	1560	1114	2674	147	147.5	128	
VS 30/15	●		30	40	1645.5	1214	2859.5	147	147.5	140	
VS 30/16	●		30	40	1730.5	1214	2944.5	147	147.5	142	
VS 30/17	●		37	50	1816	1294	3110	147	147.5	151	
VS 30/18	●		37	50	1901.5	1294	3195.5	147	147.5	153	
VS 30/19	●		37	50	1987	1294	3281	147	147.5	155	
VS 30/20	●		37	50	2072.5	1294	3366.5	147	147.5	157.5	
VS 30/21			RW8	45	60	2257.5	1230	3487.5	189	189	214.5
VS 30/22				45	60	2343	1230	3573	189	189	216.5
VS 30/23		45		60	2428.5	1230	3658.5	189	189	218.5	
VS 30/24		45		60	2514	1230	3744	189	189	220.5	

● = Pump available in R version (AISI 904L)

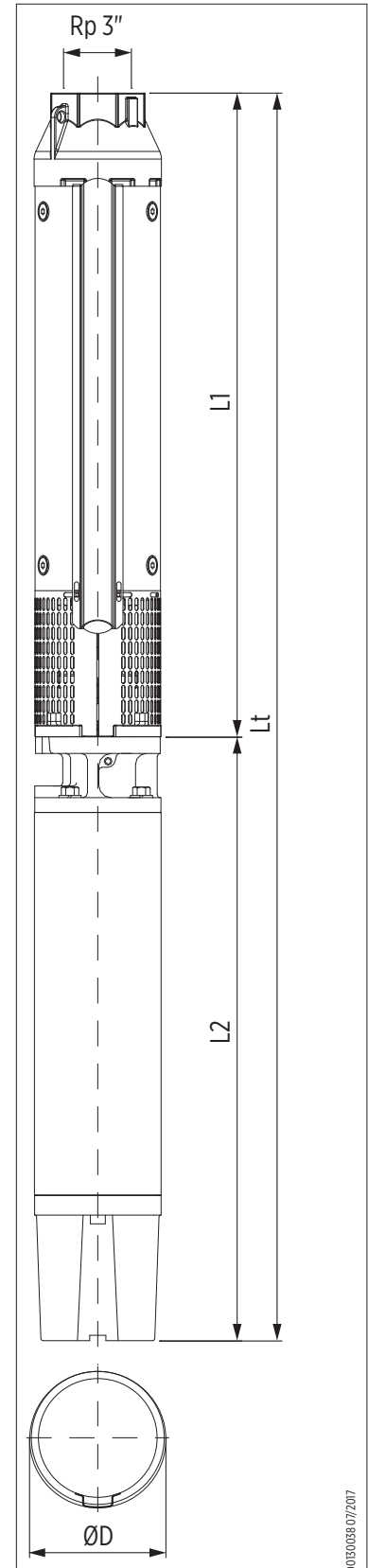

0030008 07/207

VS 30 - PERFORMANCE CURVES 60 HZ

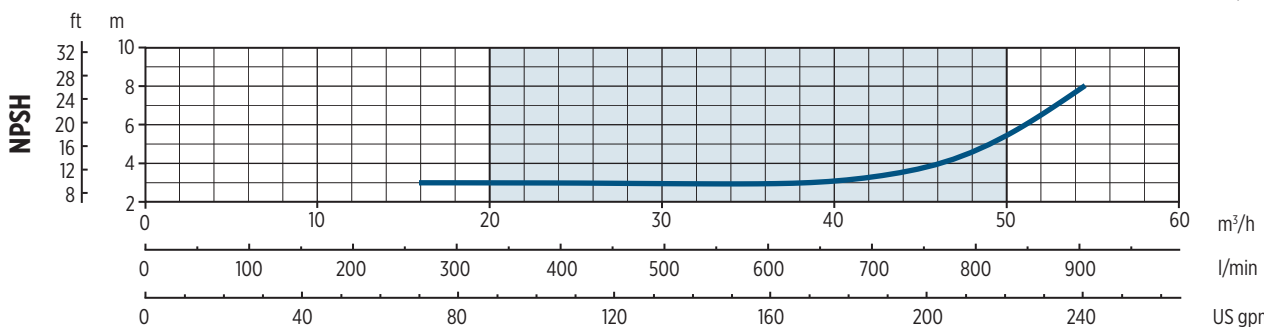
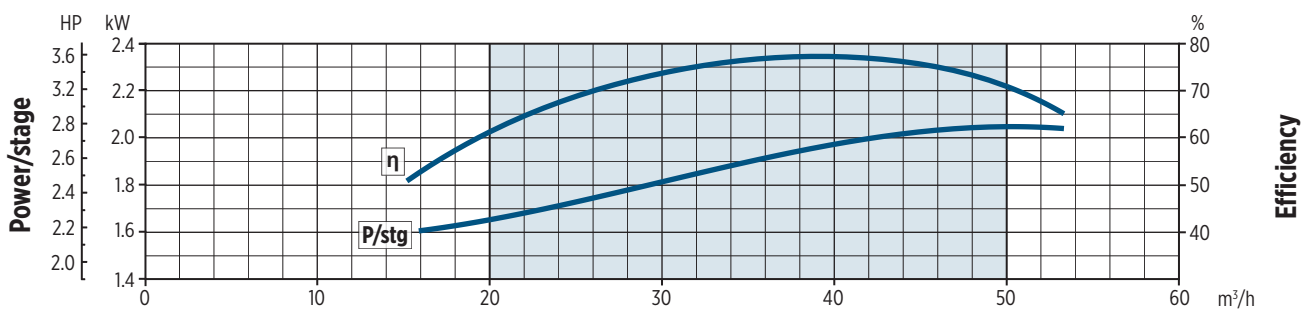
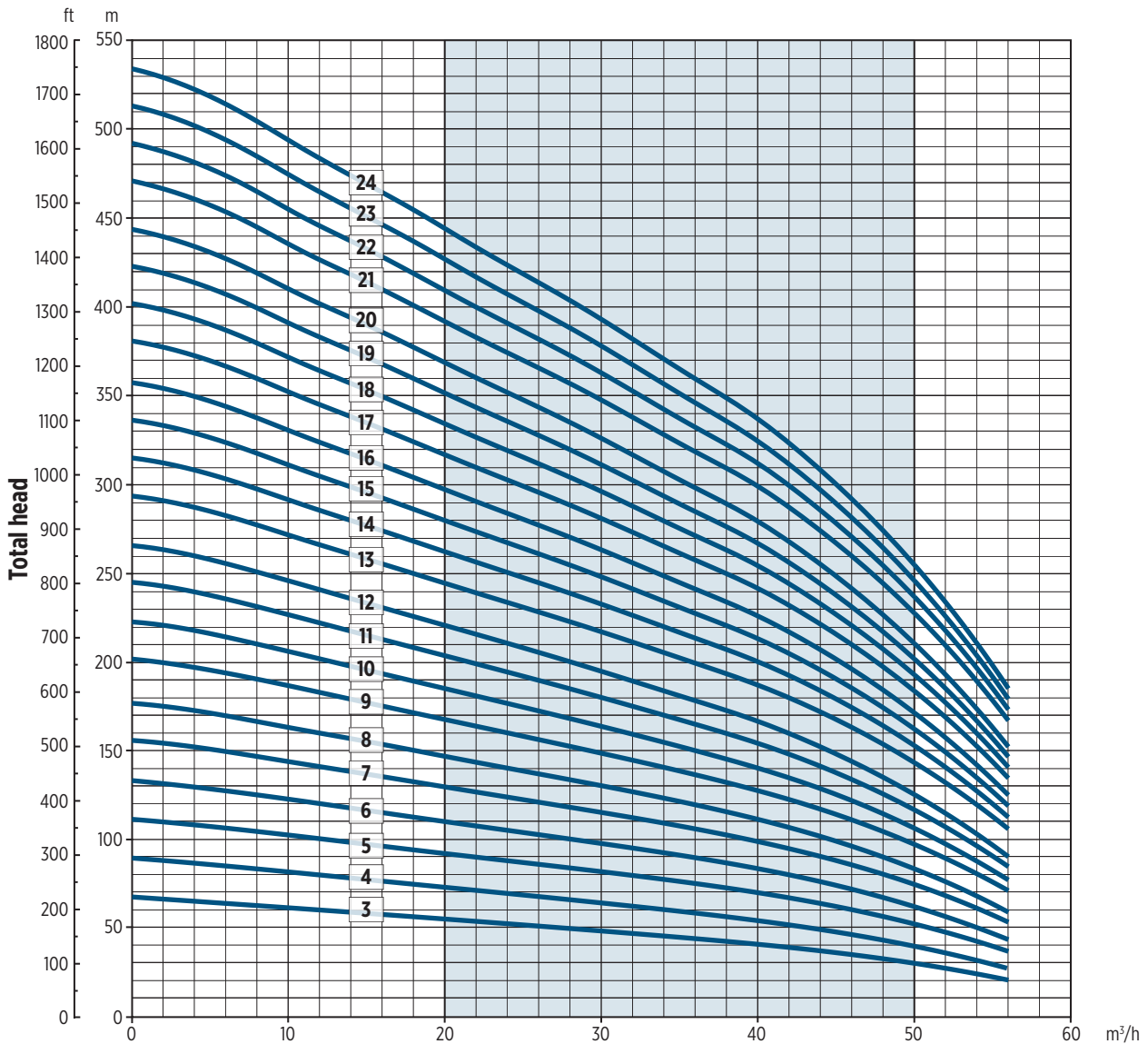

VS 30 HIGH PRESSURE - TECHNICAL DATA 60 HZ

PUMPS WITH ENCAPSULATED MOTOR

Pump model	Motor			Dimensions [mm]					Pump weight [kg]
	Type	[kW]	[HP]	L1	L2	Lt	D		
							1 cable	2 cable	
VS 30/25 HP	E8	55	75	2599	1204	3803	190.5	190.5	243
VS 30/26 HP		55	75	2684.5	1204	3888.5	190.5	190.5	245
VS 30/27 HP		55	75	2770	1204	3974	190.5	190.5	247.5
VS 30/28 HP		55	75	2855	1204	4059	190.5	190.5	249.5

PUMPS WITH REWINDABLE MOTOR

Pump model	R vers.	Motor			Dimensions [mm]					Pump weight [kg]
		Type	[kW]	[HP]	L1	L2	Lt	D		
								1 cable	2 cable	
VS 30/25 HP	RW8	55	75	2599	1340	3939	189	189	247	
VS 30/26 HP		55	75	2684.5	1340	4024.5	189	189	249	
VS 30/27 HP		55	75	2770	1340	4110	189	189	251.5	
VS 30/28 HP		55	75	2855	1340	4195	189	189	253.5	

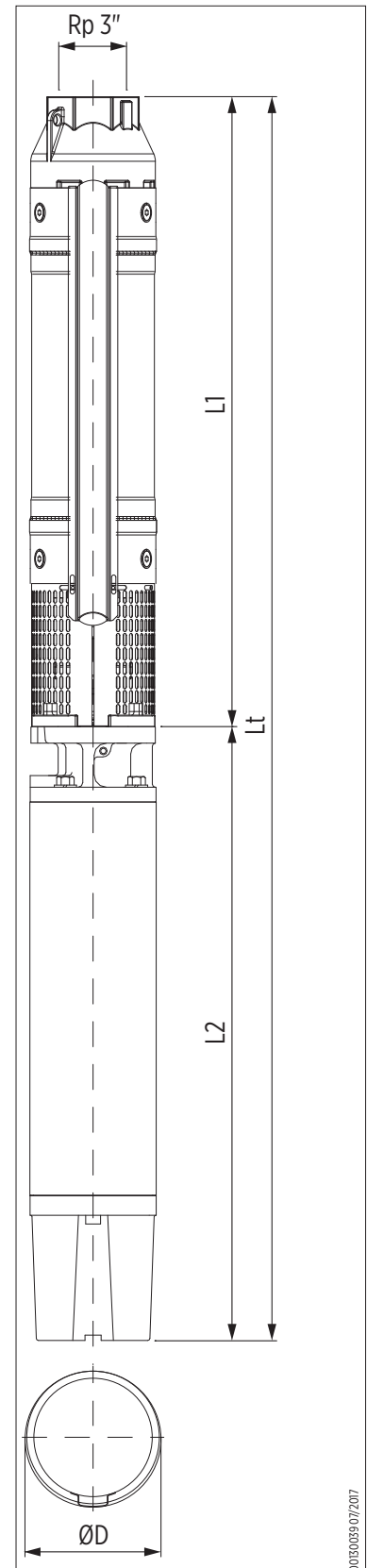

0010005907/2017



VS 30 HIGH PRESSURE - PERFORMANCE CURVES 60 HZ

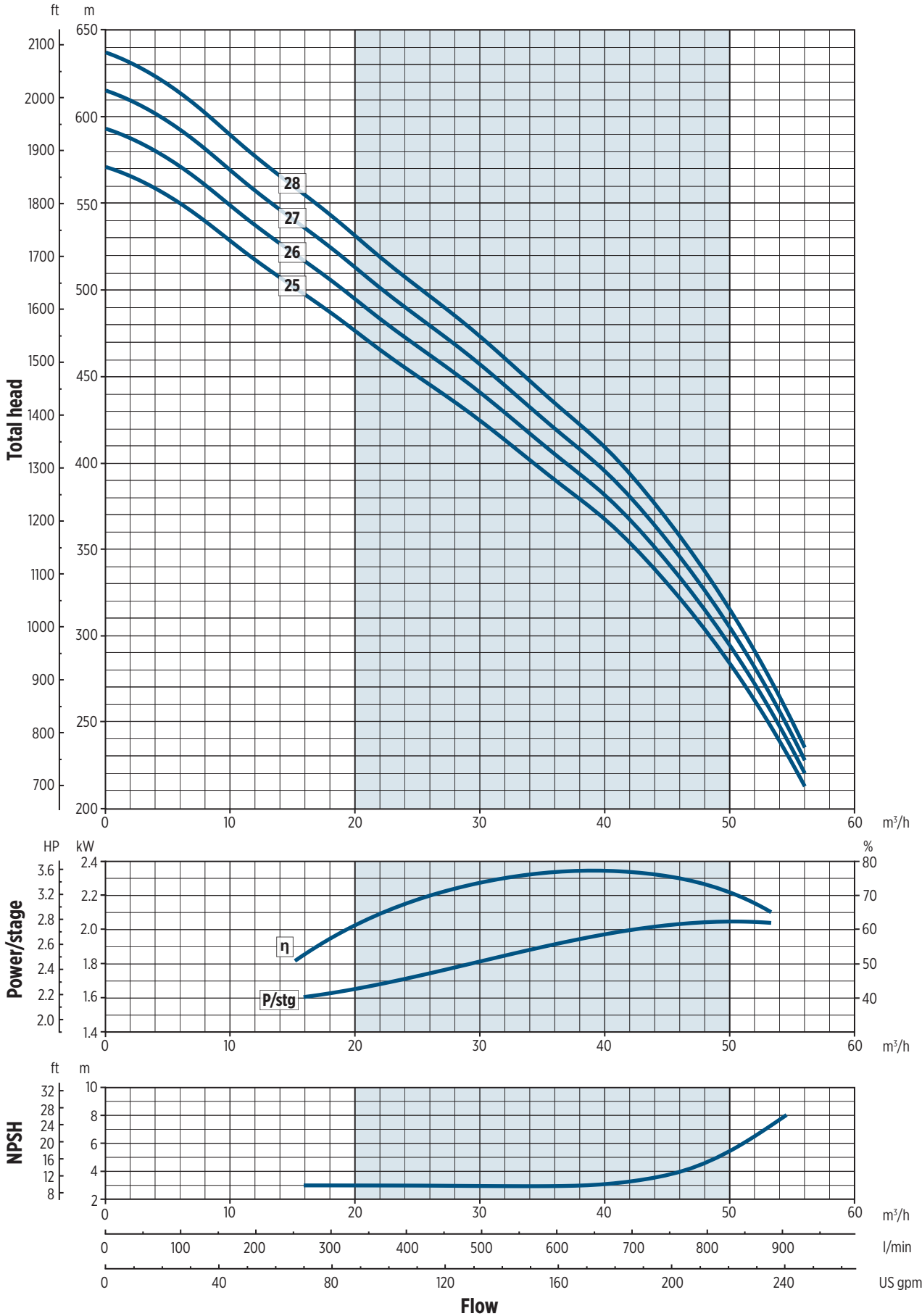

VS 46 - TECHNICAL DATA 60 HZ

PUMPS WITH ENCAPSULATED MOTOR

Pump model	Motor			Dimensions [mm]					Pump weight [kg]
	Type	[kW]	[HP]	L1	L2	Lt	D		
							1 cable	2 cable	
VS 46/2	E6	5.5	7.5	593.5	652.5	1246	142.5	-	40.5
VS 46/3		7.5	10	707.5	730.5	1438	142.5	-	47
VS 46/4		9.3	12.5	591.5	614.5	1206	143	144.5	54.5
VS 46/5		11	15	705.5	646	1351.5	143	144.5	61
VS 46/6		15	20	819.5	678.5	1498	143	144.5	66.5
VS 46/7		15	20	933.5	711	1644.5	143	144.5	72.5
VS 46/8		18.5	25	1047	776	1823	143	144.5	80.5
VS 46/9		18.5	25	1161	776	1937	143	144.5	83
VS 46/10		22	30	1275	841.5	2116.5	143	144.5	92.5
VS 46/11		22	30	1389	841.5	2230.5	143	144.5	95.5
VS 46/12		30	40	1503	906.5	2409.5	143	144.5	104
VS 46/13		30	40	1617	906.5	2523.5	143	144.5	106.5
VS 46/14		30	40	1730.5	1036.5	2767	143	144.5	123.5
VS 46/15		37	50	1844.5	1036.5	2881	143	144.5	126
VS 46/16		37	50	1958.5	1036.5	2995	143	144.5	129
VS 46/17		37	50	2072.5	1421.5	3494	143	144.5	185.5
VS 46/18		37	50	2186	1421.5	3607.5	143	144.5	188
VS 46/19		45	60	2300	1421.5	3721.5	143	144.5	190.5
VS 46/20		45	60	2414	1421.5	3835.5	143	144.5	193.5
VS 46/21		45	60	2527.5	1574	4101.5	143	144.5	210
VS 46/22		45	60	2641.5	1574	4215.5	143	144.5	212.5

PUMPS WITH REWINDABLE MOTOR

Pump model	R vers.	Motor			Dimensions [mm]					Pump weight [kg]
		Type	[kW]	[HP]	L1	L2	Lt	D		
								1 cable	2 cable	
VS 46/2	●	RW6	5.5	7.5	591.5	699	1290.5	147	147.5	61.5
VS 46/3	●		7.5	10	705.5	719	1424.5	147	147.5	66
VS 46/4	●		9.3	12.5	819.5	749	1568.5	147	147.5	72
VS 46/5	●		11	15	933.5	779	1712.5	147	147.5	77.5
VS 46/6	●		13	17.5	1047	829	1876	147	147.5	85
VS 46/7	●		15	20	1161	874	2035	147	147.5	92.5
VS 46/8	●		18.5	25	1275	919	2194	147	147.5	99
VS 46/9	●		18.5	25	1389	919	2308	147	147.5	102
VS 46/10	●		22	30	1503	1009	2512	147	147.5	113.5
VS 46/11	●		22	30	1617	1009	2626	147	147.5	116
VS 46/12	●		26	35	1730.5	1114	2844.5	147	147.5	129.5
VS 46/13	●		30	40	1844.5	1214	3058.5	147	147.5	142
VS 46/14	●		30	40	1958.5	1214	3172.5	147	147.5	145
VS 46/15	●		37	50	2072.5	1294	3366.5	147	147.5	154.5
VS 46/16	●		37	50	2186	1294	3480	147	147.5	157
VS 46/17	●		37	50	2300	1294	3594	147	147.5	159.5
VS 46/18			37	50	2414	1294	3708	147	147.5	162.5
VS 46/19			RW8	45	60	2627.5	1230	3857.5	189	189
VS 46/20		45		60	2741.5	1230	3971.5	189	189	222.5
VS 46/21		45		60	2855	1230	4085	189	189	225
VS 46/22		45		60	2969	1230	4199	189	189	227.5

● = Pump available in R version (AISI 904L)

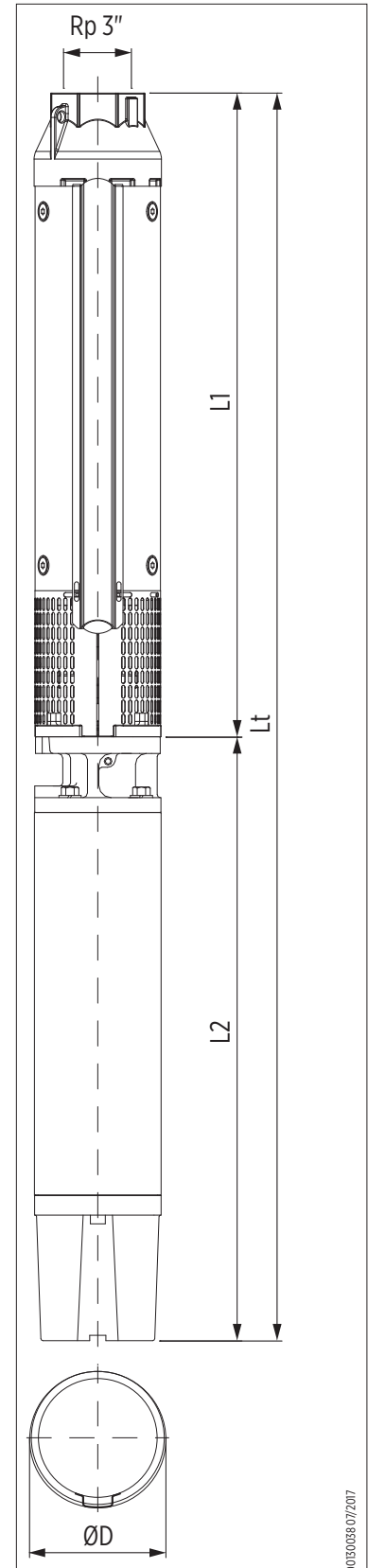

0030038 07/2017

VS 46 - PERFORMANCE CURVES 60 HZ

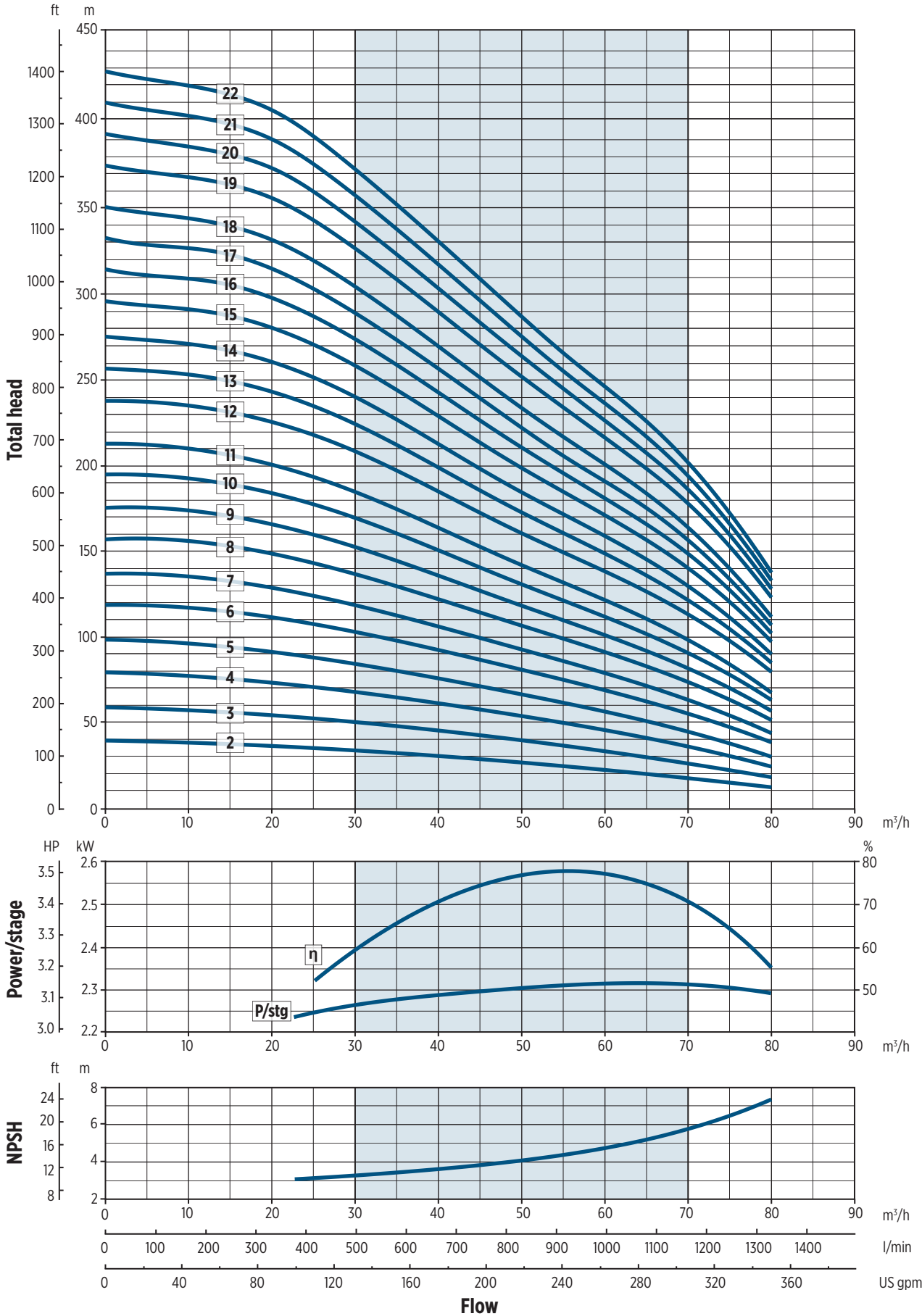

VS 46 HIGH PRESSURE - TECHNICAL DATA 60 HZ

PUMPS WITH ENCAPSULATED MOTOR

Pump model	Motor			Dimensions [mm]					Pump weight [kg]
	Type	[kW]	[HP]	L1	L2	Lt	D		
							1 cable	2 cable	
VS 46/23 HP	E8	55	75	3083	1204	4287	190,5	190,5	249,5
VS 46/24 HP		55	75	3196,5	1204	4400,5	190,5	190,5	252
VS 46/25 HP		55	75	3310,5	1204	4514,5	190,5	190,5	254,5
VS 46/26 HP		55	75	3424	1204	4628	190,5	190,5	257,5

PUMPS WITH REWINDABLE MOTOR

Pump model	R vers.	Motor			Dimensions [mm]					Pump weight [kg]
		Type	[kW]	[HP]	L1	L2	Lt	D		
								1 cable	2 cable	
VS 46/23 HP	RW8	55	75	3083	1340	4423	189	189	253,5	
VS 46/24 HP		55	75	3196,5	1340	4536,5	189	189	256	
VS 46/25 HP		55	75	3310,5	1340	4650,5	189	189	258,5	
VS 46/26 HP		55	75	3424	1340	4764	189	189	261,5	

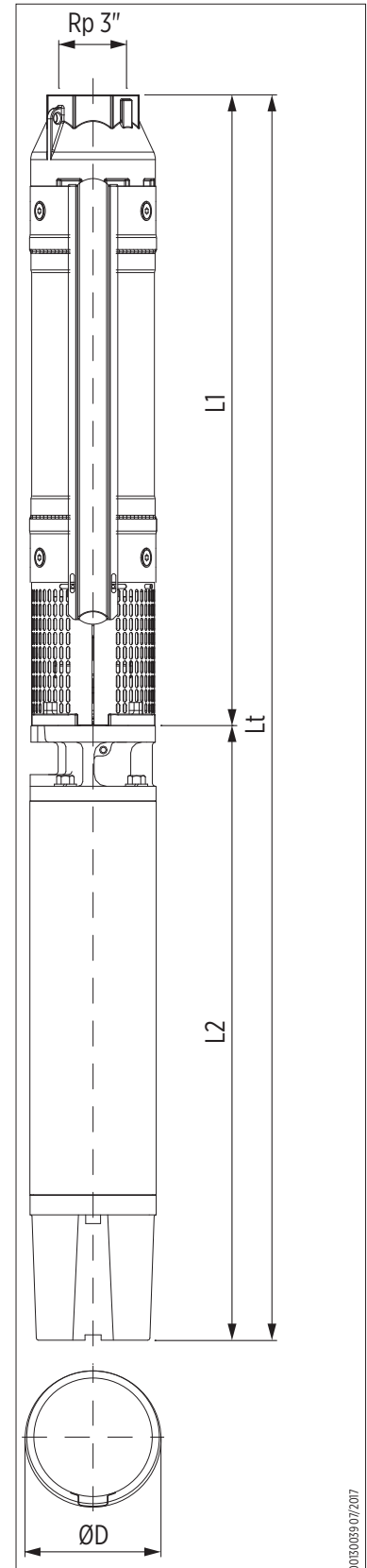

0013005907/2017

VS 46 HIGH PRESSURE - PERFORMANCE CURVES 60 HZ

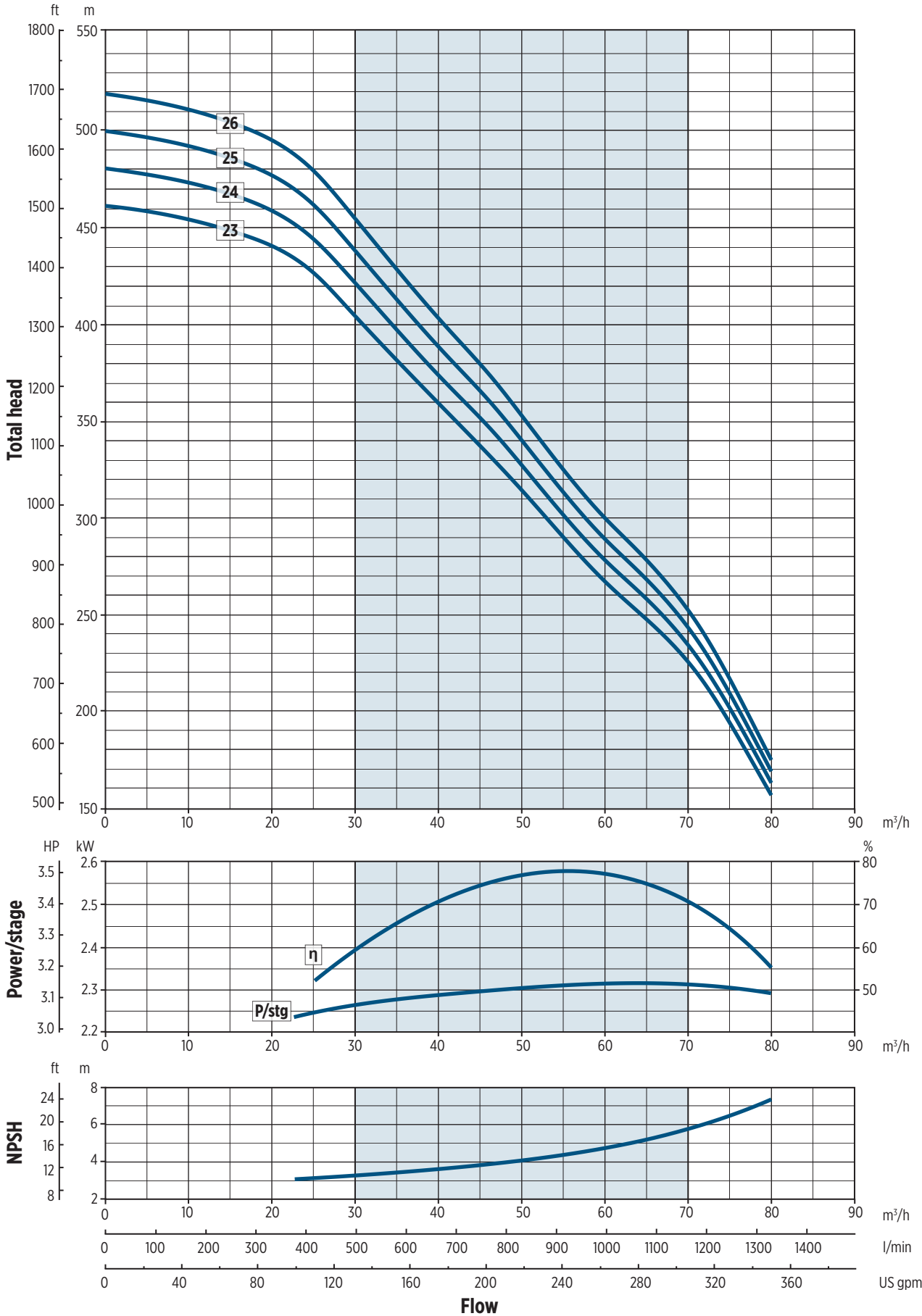

VS 65 - TECHNICAL DATA 60 HZ

PUMPS WITH ENCAPSULATED MOTOR

Pump model	Motor			Dimensions [mm]					Pump weight [kg]
	Type	[kW]	[HP]	L1	L2	Lt	D		
							1 cable	2 cable	
VS 65/2	E4	5.5	7.5	593.5	652.5	1246	142.5	-	40.5

* Kit 14251005 necessary for 4" motors

VS 65/2	E6	5.5	7.5	591.5	614.5	1206	143	144.5	54.5
VS 65/3		9.3	12.5	705.5	678.5	1384	143	144.5	63.5
VS 65/4		11	15	819.5	711	1530.5	143	144.5	70
VS 65/5		15	20	933.5	776	1709.5	143	144.5	78
VS 65/6		15	20	1047	776	1823	143	144.5	80.5
VS 65/7		18.5	25	1161	841.5	2002.5	143	144.5	90
VS 65/8		22	30	1275	906.5	2181.5	143	144.5	99
VS 65/9		30	40	1389	1036.5	2425.5	143	144.5	116
VS 65/10		30	40	1503	1036.5	2539.5	143	144.5	118.5
VS 65/11		30	40	1617	1036.5	2653.5	143	144.5	121
VS 65/12		37	50	1730.5	1421.5	3152	143	144.5	177.5
VS 65/13		37	50	1844.5	1421.5	3266	143	144.5	180.5
VS 65/14		37	50	1958.5	1421.5	3380	143	144.5	183
VS 65/15		45	60	2072.5	1574	3646.5	143	144.5	199.5
VS 65/16		45	60	2186	1574	3760	143	144.5	202
VS 65/17		45	60	2300	1574	3874	143	144.5	205
VS 65/18		45	60	2414	1574	3988	143	144.5	207.5

PUMPS WITH REWINDABLE MOTOR

Pump model	R vers.	Motor			Dimensions [mm]					Pump weight [kg]
		Type	[kW]	[HP]	L1	L2	Lt	D		
								1 cable	2 cable	
VS 65/2	●	RW6	5.5	7.5	591.5	699	1290.5	147	147.5	61.5
VS 65/3	●		9.3	12.5	705.5	749	1454.5	147	147.5	69
VS 65/4	●		11	15	819.5	779	1598.5	147	147.5	75
VS 65/5	●		13	17.5	933.5	829	1762.5	147	147.5	82.5
VS 65/6	●		15	20	1047	874	1921	147	147.5	90
VS 65/7	●		18.5	25	1161	919	2080	147	147.5	96.5
VS 65/8	●		22	30	1275	1009	2284	147	147.5	108.5
VS 65/9	●		26	35	1389	1114	2503	147	147.5	122
VS 65/10	●		26	35	1503	1114	2617	147	147.5	124.5
VS 65/11	●		30	40	1617	1214	2831	147	147.5	137
VS 65/12	●		37	50	1730.5	1294	3024.5	147	147.5	146.5
VS 65/13	●		37	50	1844.5	1294	3138.5	147	147.5	149.5
VS 65/14	●		37	50	1958.5	1294	3252.5	147	147.5	152
VS 65/15			RW8	45	60	2172.5	1230	3402.5	189	189
VS 65/16		45		60	2286	1230	3516	189	189	212
VS 65/17		45		60	2400	1230	3630	189	189	215
VS 65/18		45		60	2514	1230	3744	189	189	217.5

● = Pump available in R version (AISI 904L)

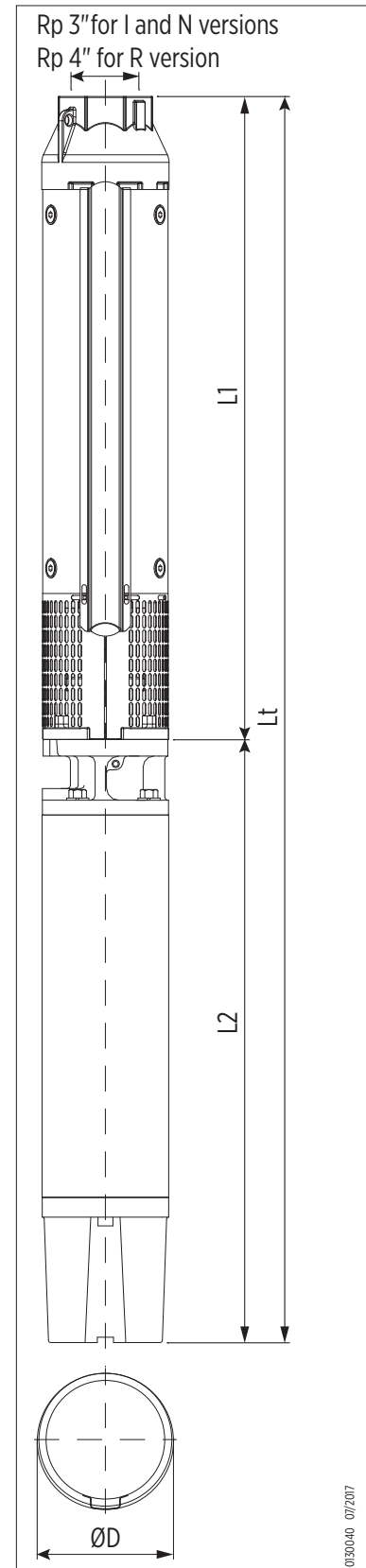

0030040 07/2017

VS 65 - PERFORMANCE CURVES 60 HZ

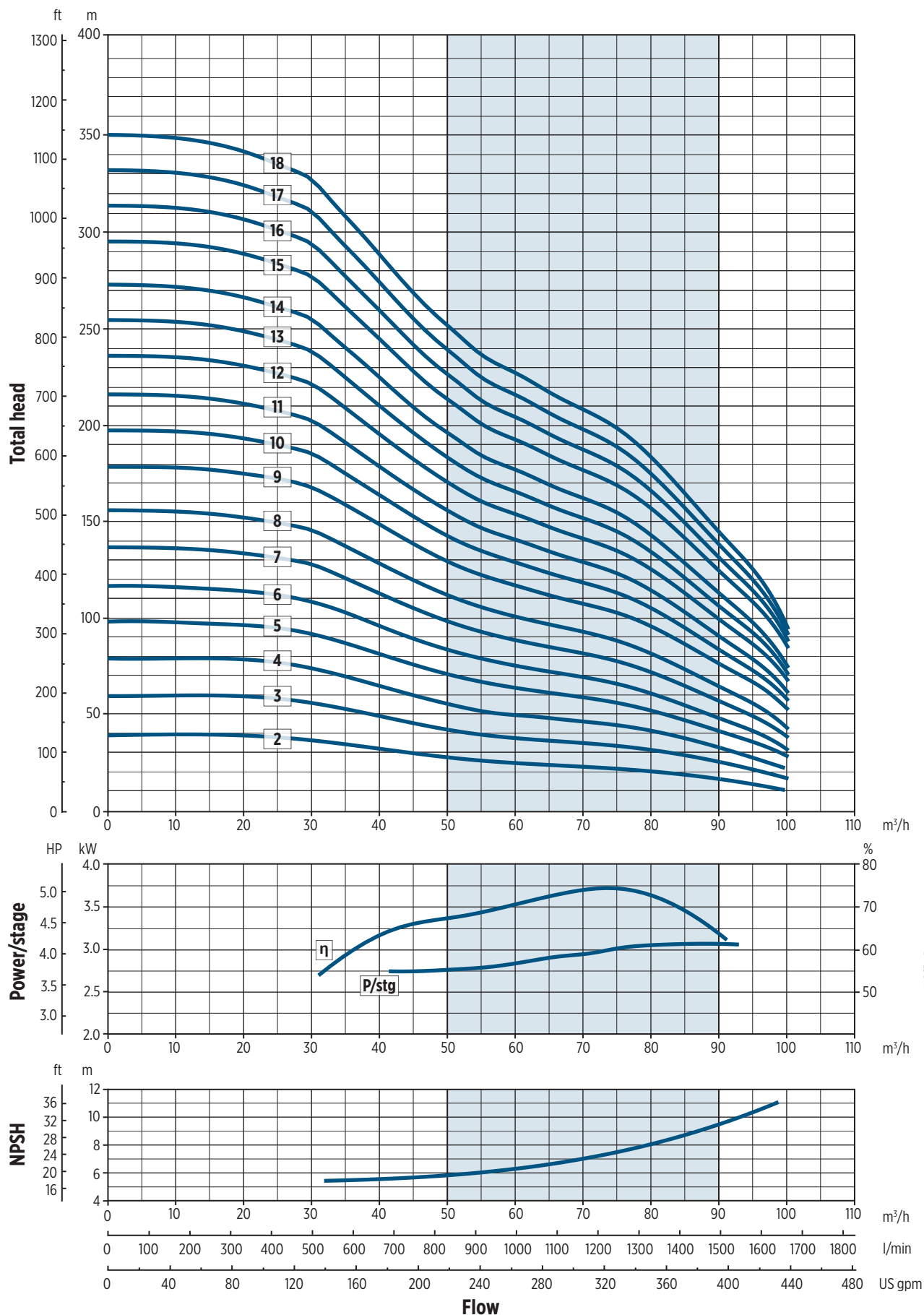

00T2016AEN 09/2018

VS 65 HIGH PRESSURE - TECHNICAL DATA 60 HZ

PUMPS WITH ENCAPSULATED MOTOR

Pump model	Motor			Dimensions [mm]					Pump weight [kg]
	Type	[kW]	[HP]	L1	L2	Lt	D		
							1 cable	2 cable	
VS 65/19 HP	E8	55	75	2627.5	1204	3831.5	190.5	190.5	239
VS 65/20 HP		55	75	2741.5	1204	3945.5	190.5	190.5	241.5
VS 65/21 HP		55	75	2855	1204	4059	190.5	190.5	244.5

PUMPS WITH REWINDABLE MOTOR

Pump model	R vers.	Motor			Dimensions [mm]					Pump weight [kg]
		Type	[kW]	[HP]	L1	L2	Lt	D		
								1 cable	2 cable	
VS 65/19 HP	RW8	55	75	2627.5	1340	3967.5	189	189	243	
VS 65/20 HP		55	75	2741.5	1340	4081.5	189	189	245.5	
VS 65/21 HP		55	75	2855	1340	4195	189	189	248.5	

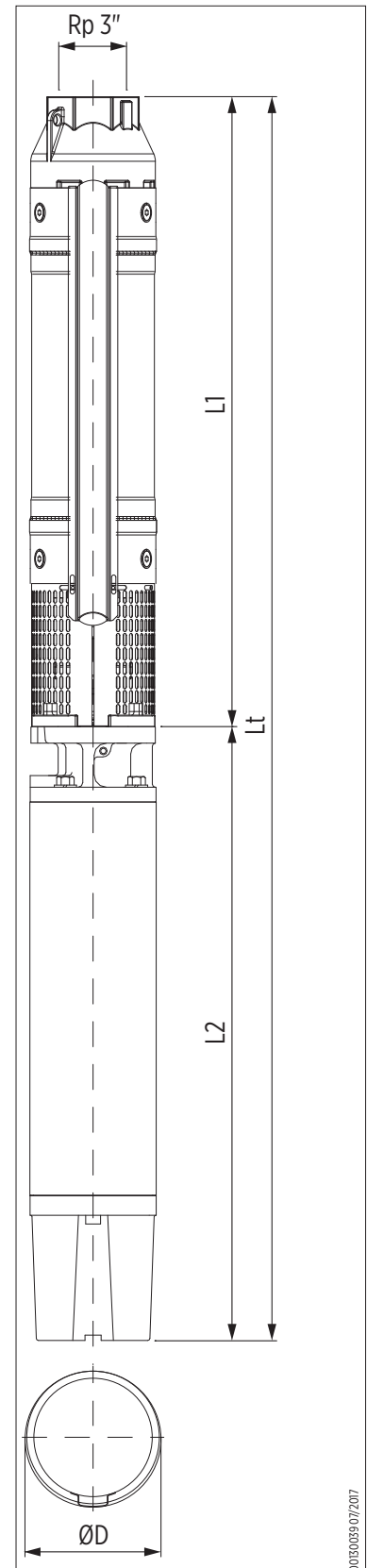

00103005907/2017



VS 65 HIGH PRESSURE - PERFORMANCE CURVES 60 HZ

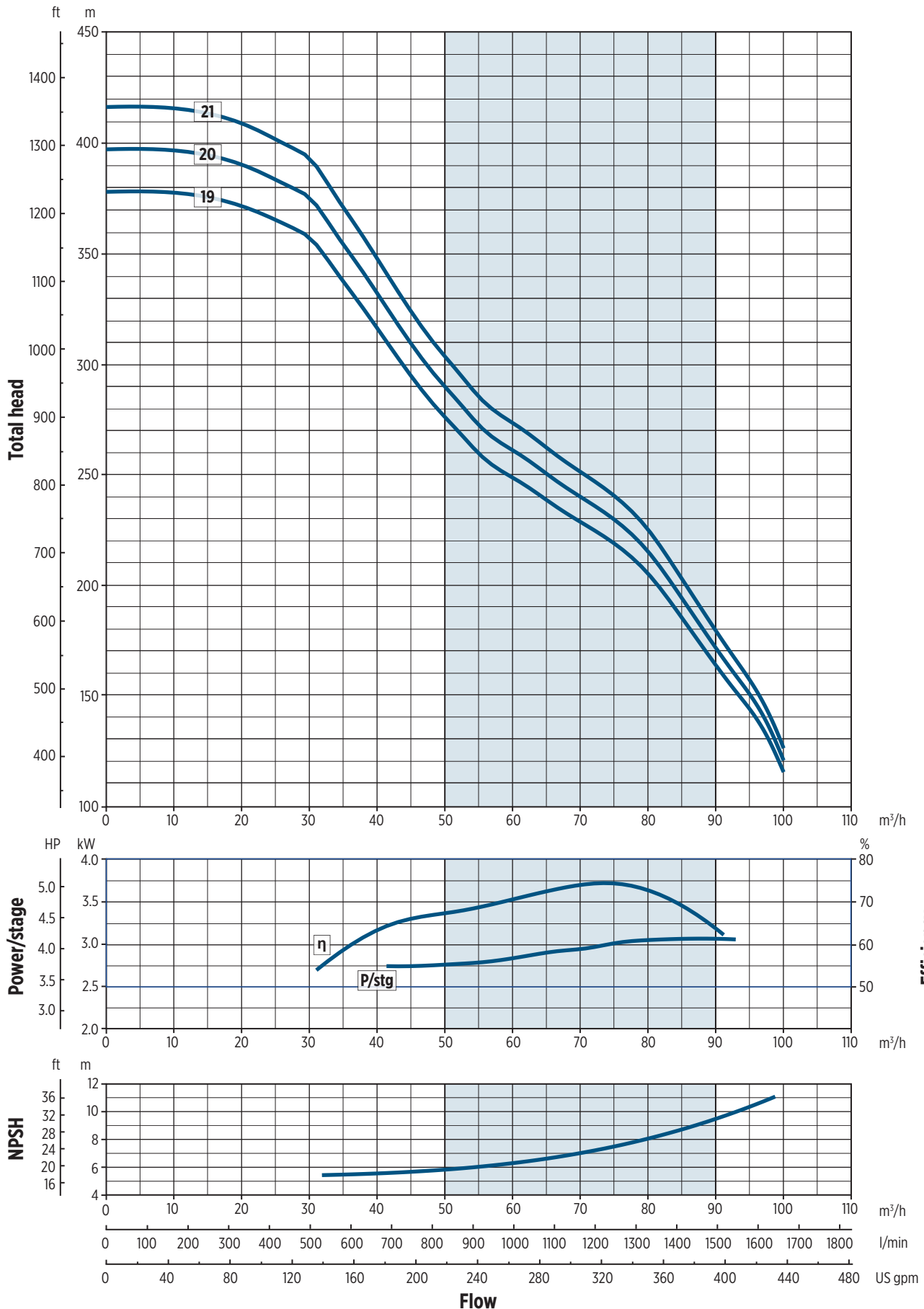

00T0165EN 09/2018

SPARE PARTS

VS 14-19-25*

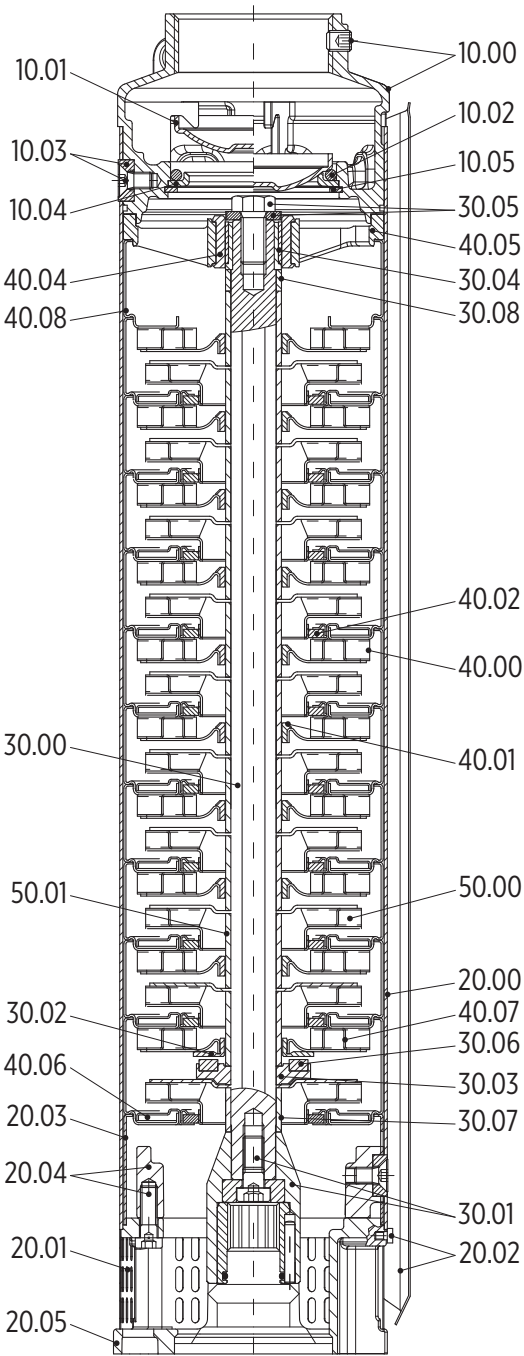

Ref. N.	Description
10.00	Discharge head
10.01	Valve
10.04	
10.05	
10.02	Sealing O-ring
10.03	Outer case locking nuts
20.00	Outer case
20.01	Suction strainer
20.02	Cable guard and screws
20.03	Initial spacer
20.04	Flange
20.04	Screws
20.05	Motor adapter
20.06	4" motor flange
20.06	4" coupling adapter
30.00	Pump shaft
30.01	Coupling
30.02	Upper up-thrust washer
30.03	Lower up-thrust washer
30.04	Upper journal sleeve
30.05	Screw and washer
30.06	Up-thrust ring
30.07	Lower / Upper spacer
30.08	
40.00	Diffuser
40.01	Secondary bearing bush
40.02	Floating neck ring
40.04	Bearing bush
40.05	Upper bearing guide
40.06	First diffuser
40.07	Diffuser with upper up-thrust washer
40.08	Last diffuser
50.00	Impeller
50.01	Impeller spacer

MOTOR ADAPTER 6x4

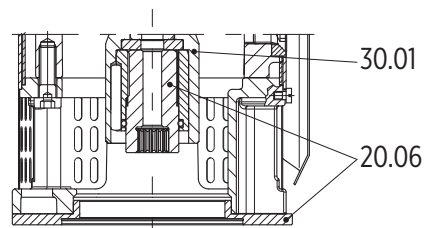

* IMPORTANT: VS25 models only for sales out of EU or as a component of fire-fighting units

VS 30-46-65

Ref. N.	Description
10.00	Discharge head
10.01	Valve
10.04	
10.05	
10.02	Sealing O-ring
10.03	Outer case locking nuts
20.00	Outer case
20.01	Suction strainer
20.02	Cable guard and screws
20.03	Initial spacer
20.04	Flange
20.05	Motor adapter
20.06	4" motor flange
20.06	4" coupling adapter
20.07	8" motor adapter
20.07	Bolts and washers
30.00	Pump shaft

Ref. N.	Description
30.01	Coupling
30.03	Lower up-thrust washer
30.04	Upper journal sleeve
30.05	Screw and washer
30.06	Up-thrust ring
40.00	Diffuser
40.01	Secondary bearing bush
40.02	Floating neck ring
40.03	Flange clamping neck ring
40.04	Bearing bush
40.05	Last - Intermediate diffuser
50.00	Wear ring
50.05	Impeller
51.01	Split cone
51.02	Split cone nut
51.03	Intermediate cone nut
51.04	Up-thrust split cone nut
51.06	Intermediate impeller with screw

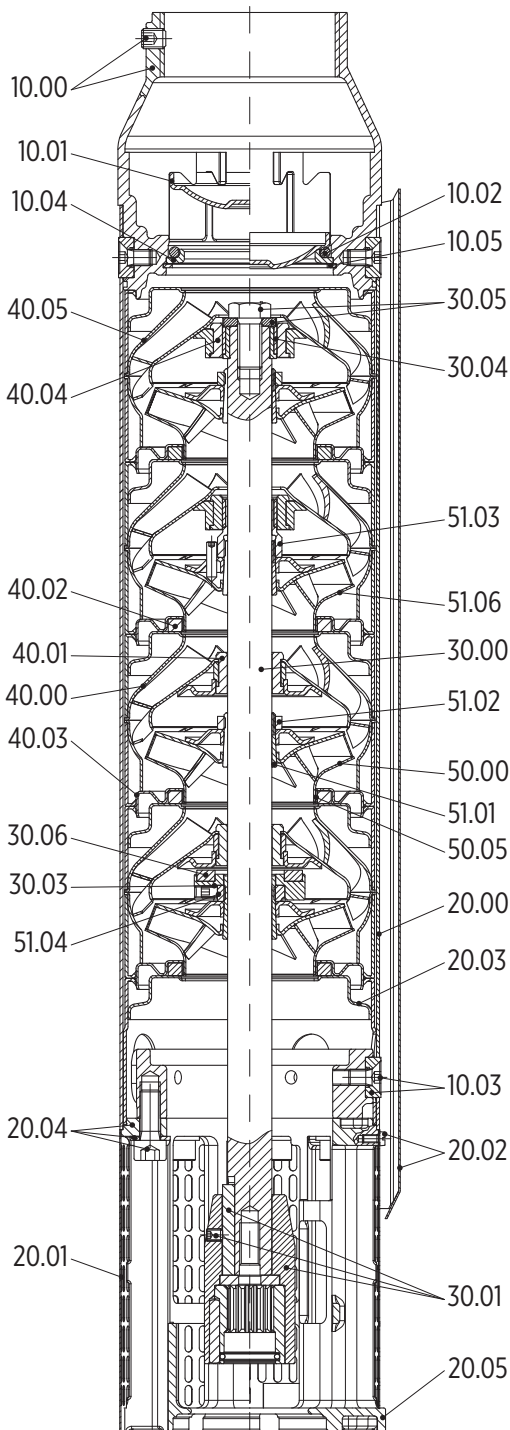

MOTOR ADAPTER 6x4

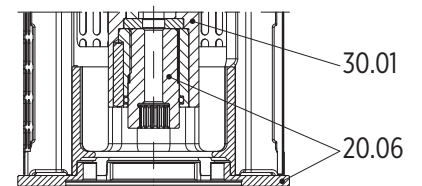

MOTOR ADAPTER 6x8

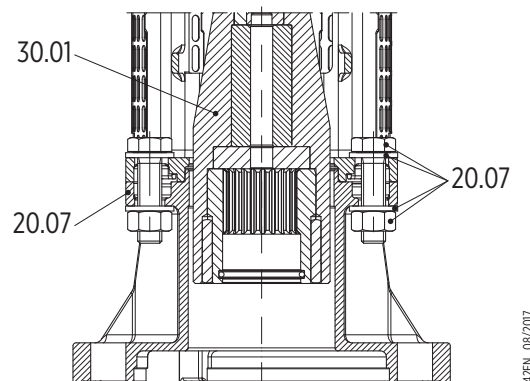

0015004ZEN 08/2017

0015004ZEN 08/2017

MOTOR ADAPTER AND DIMENSIONS

VS 14-19-25*

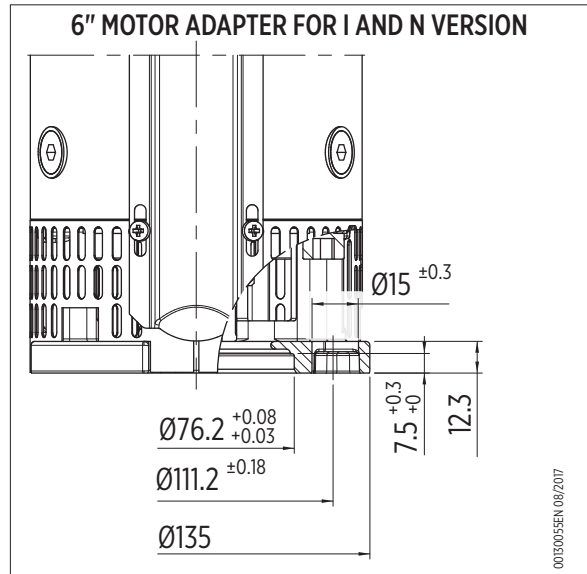
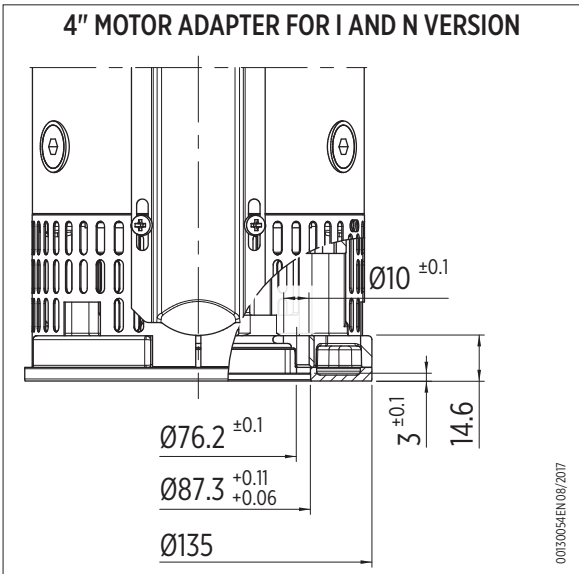

* IMPORTANT: VS25 models only for sales out of EU or as a component of fire-fighting units

VS 30-46-65

4" MOTOR ADAPTER FOR I AND N VERSION

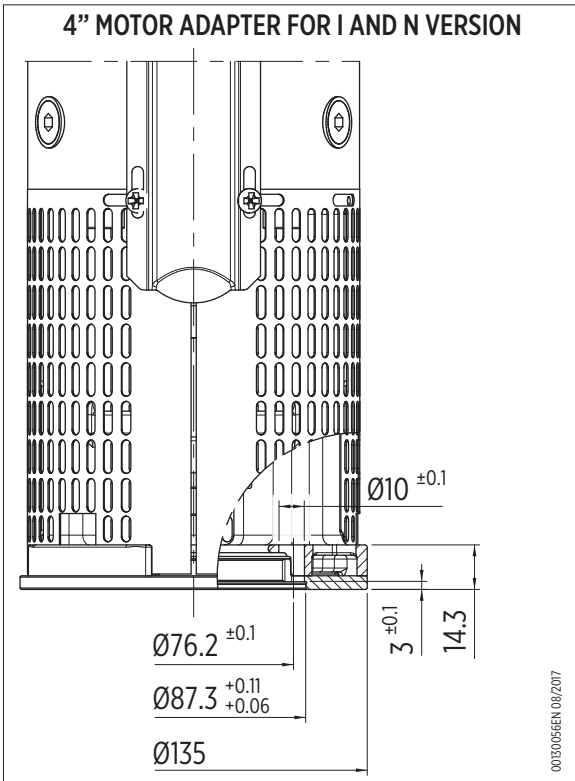

6" MOTOR ADAPTER FOR I, N AND R VERSION

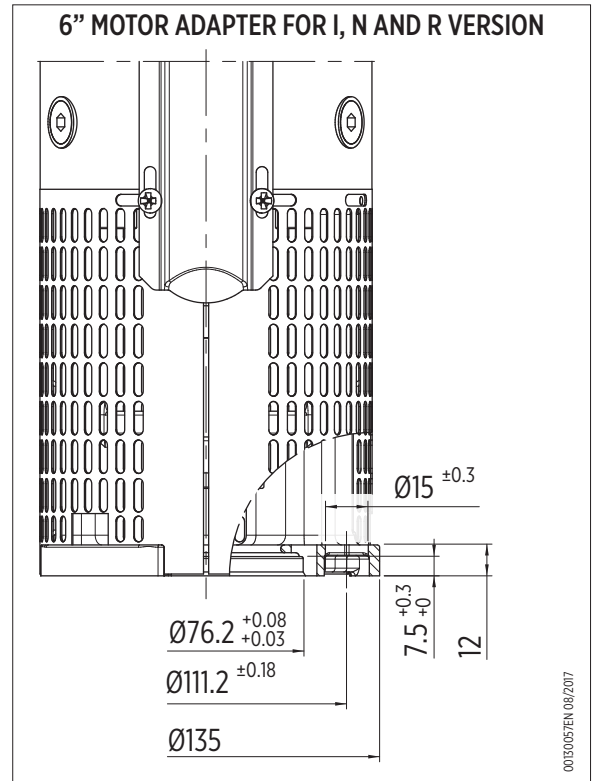

8" MOTOR ADAPTER FOR I AND N VERSION

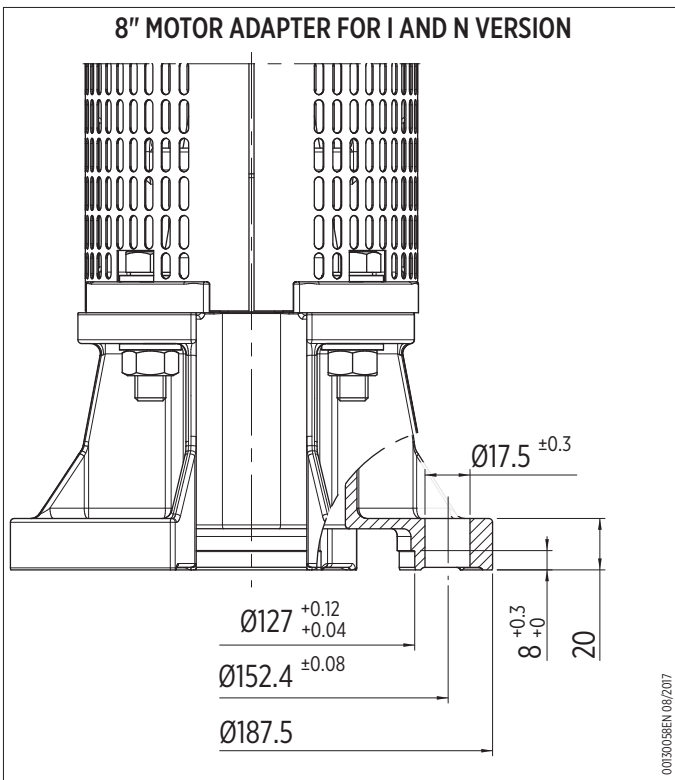



VS 8" Series

VS 78-97

8" STAINLESS STEEL SUBMERSIBLE PUMPS

APPLICATION

- Municipal water works
- Water distribution and pressure boosting
- Irrigation and sprinkler systems, water treatment plants, filtration and reverse osmosis
- Industrial cooling and processing
- Mining industry, drainage and dewatering
- Fire-fighting equipment
- Fountains

FEATURES

- Stainless steel components for durability and robustness, guaranteeing longevity and trouble-free operation. Many design technical features make this pump range very compact and extremely reliable, to ensure applications in the most complex and severe conditions.
- External stainless steel sleeve to improve stiffness and assure permanent alignment of all the components
- Motor adapter and discharge head may be removed without disturbing the impeller / diffuser stack
- Built-in check valve and over size pump shaft
- Easy maintenance without the need of special tools

PUMP SPECIFICATION

- Flow: up to 160 m³/h at 60 Hz
- Head: up to 524 m (51 Bar) at 60 Hz
- Water temperature range:
 - Minimum: -5 °C
 - Maximum: +90 °C (+60 °C for NBR parts)
- Maximum allowable amount of sand 100 g/m³
- Rotation: counter clockwise when looking into the discharge
- Pump can work continuously in vertical or horizontal position

MOTOR SPECIFICATION

- Motor adapter in compliance with NEMA standard
- For more information consult the product catalog of Submersible motors

AVAILABLE ON REQUEST

- Pump material:
 - 316 Stainless steel (N) version (DIN/EN 1.4401)
 - 904L (R) version (DIN/EN 1.4539)
 - See specified material variant in Materials/fluids compatibility table on page 50
- Double cable guard
- Discharge head:
 - Rp 4" for I and N versions
 - Rp 6" for R version
- Pump with NBR rubber parts

FAMILY CURVES

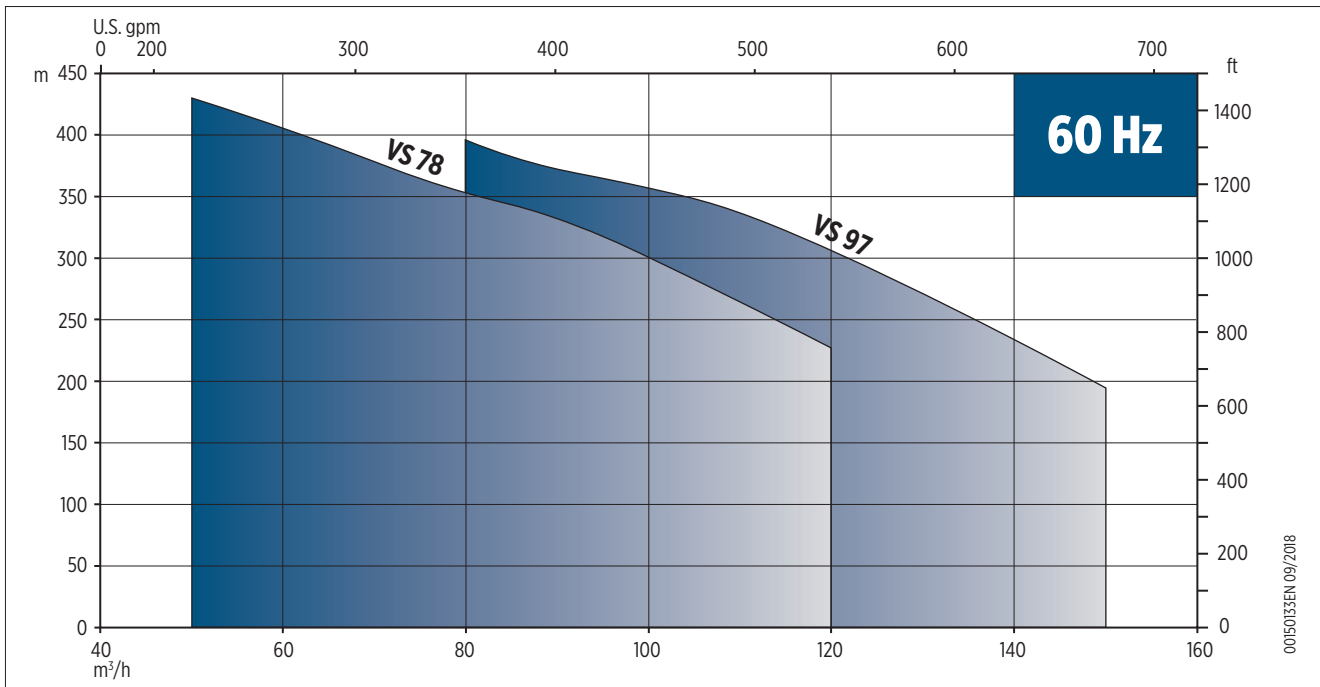

PUMP IDENTIFICATION CODE

VS 78 / 15 I M8 RP5 E1 P HP SD

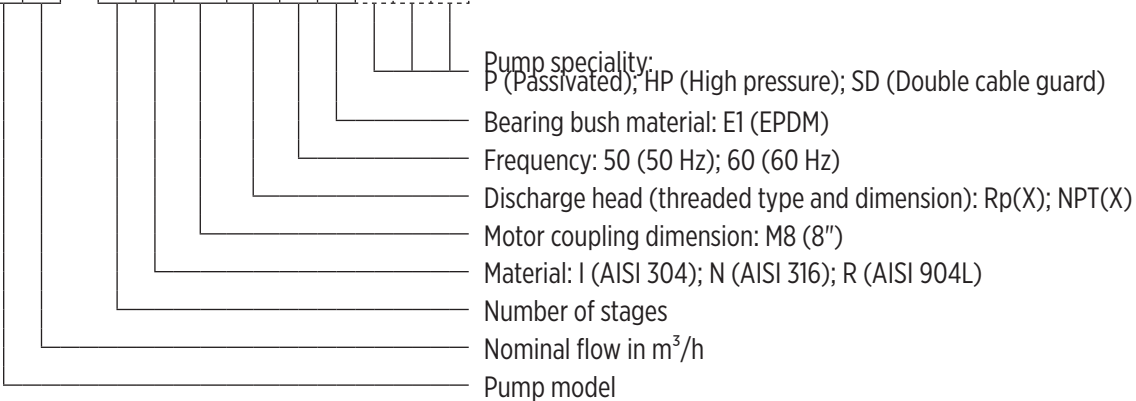

00140011 06/2021

PUMPS AND MOTORS RANGE

Pump model	Versions			Motor power range [kW]	
	I EN 1.4301	N EN 1.4401	R EN 1.4539	I e N	R
	VS 78	○	○	●	7.5 ÷ 93
VS 97	○	○	●	9.3 ÷ 110	30 ÷ 93

○ = Version available ● = Version available only with 6" motor coupling

MATERIALS/FLUIDS COMPATIBILITY

Ref. No.	Parts description	Material	Standard						
			I Version		N Version		R Version		
			ASTM	DIN/EN	ASTM	DIN/EN	ASTM	DIN/EN	
10.00	Discharge head	Stainless steel	CF8 (304)	1.4308	CF8M (316)	1.4408	CD4MCuN (904L)	1.4517	
10.01	Valve	Stainless steel	316	1.4401	316	1.4401	2205/904L	1.4462/1.4460	
10.02	Sealing O-ring	EPDM							
10.03	Outer case locking nuts	Stainless steel	316	1.4401	316	1.4401	2205	1.4462	
10.04	Valve support	Stainless steel and PTFE	316	1.4401	316	1.4401	904L	1.4539	
10.05	Seeger ring	Stainless steel	316	1.4401	316	1.4401	904L	1.4539	
20.00	Outer case	Stainless steel	304	1.4301	316	1.4401	2205	1.4462	
20.01	Suction strainer	Stainless steel	316	1.4401	316	1.4401	904L	1.4539	
20.02	Cable guard and screws	Stainless steel	316	1.4401	316	1.4401	904L	1.4539	
20.03	Initial spacer	Stainless steel	316	1.4401	316	1.4401	904L	1.4539	
20.04	Flange	Stainless steel	CF8 (304)	1.4308	CF8M (316)	1.4408	CD4MCuN (904L)	1.4517	
	Screws		304	1.4301	316	1.4401	904L	1.4539	
20.05	Motor adapter	Stainless steel	CF8 (304)	1.4308	CF8M (316)	1.4408	CD4MCuN (904L)	1.4517	
30.00	Pump shaft	Stainless steel	329	1.4460	329	1.4460	329	1.4460	
30.01	Coupling	Stainless steel	431/329	1.4057/ 1.4460	316/329	1.4401/ 1.4460	2205/904L	1.4462/1.4539	
30.02	Upper up-thrustwasher	Stainless steel	329	1.4460	329	1.4460	329	1.4460	
30.03	Lower up-thrust washer	Stainless steel	329	1.4460	329	1.4460	329	1.4460	
30.04	Upper journal sleeve ⁽¹⁾	Alluminum Oxide (Alumina)	Al2 O3 (99,7%)						
30.05	Screw and washer ⁽¹⁾	Stainless steel	316	1.4401	316	1.4401	904L/329	1.4539/1.4460	
30.06	Up-thrust ring	PTFE + Graphite							
40.00	Diffuser	Stainless steel	304	1.4301	316	1.4401	904L	1.4539	
40.01	Secondary bearing bush	EPDM							
40.02	Floating neck ring	PTFE							
40.03	Flange clamping neck ring	Stainless steel	316	1.4401	316	1.4401	904L	1.4539	
50.00	Impeller	Stainless steel	316	1.4401	316	1.4401	904L	1.4539	
51.01	Split cone	Stainless steel	316	1.4401	316	1.4401	329	1.4460	
51.02	Split cone nut	Stainless steel	316	1.4401	316	1.4401	329	1.4460	

1) Only for models with more that 8 stages



HYDRAULIC PERFORMANCE AT 60 HZ

VS 78

Pump model	R vers.	RATED POWER		Q = DELIVERY												
				m ³ /h 0	10	20	30	40	50	60	70	80	90	100	110	120
				l/min 0	166.6	333.3	500	666.6	833.3	1000	1166.6	1333.3	1500	1666.6	1833.3	2000
[kW]	[HP]	H = TOTAL HEAD METERS COLUMN OF WATER [m]														
VS 78/2	●	11	15	59.5	59.0	58.0	56.5	55.0	52.0	49.0	56.0	53.0	40.0	36.0	31.5	27.0
VS 78/3	●	18.5	25	89.5	89.0	87.5	85.5	82.5	79.0	74.0	69.5	64.5	60.5	54.5	47.5	40.5
VS 78/4	●	22	30	118.0	117.5	115.0	112.0	108.5	103.0	97.0	91.0	84.0	79.0	71.0	62.0	52.0
VS 78/5	●	30	40	149.0	148.5	146.0	142.0	138.0	131.5	123.5	116.0	107.5	101.0	91.0	79.5	68.0
VS 78/6	●	37	50	178.0	177.5	174.0	170.0	164.5	157.0	147.5	138.0	128.0	120.0	108.5	94.5	80.5
VS 78/7	●	37	50	206.0	205.0	201.0	196.0	190.0	180.5	169.5	158.5	147.0	137.5	123.5	108.0	91.0
VS 78/8	●	45	60	236.5	236.0	231.5	226.0	218.5	208.0	195.5	183.0	170.0	159.0	143.5	125.0	106.0
VS 78/9	●	55	75	272.5	272.0	267.0	261.0	253.0	241.5	228.0	214.0	199.0	186.5	169.5	149.0	127.5
VS 78/10	●	55	75	301.5	301.0	295.5	288.5	280.0	267.0	251.5	236.0	219.5	206.0	187.0	164.0	140.5
VS 78/11	●	75	100	334.5	334.0	328.0	321.0	312.0	298.0	281.0	264.0	245.5	230.5	210.0	184.0	158.5
VS 78/12	●	75	100	364.5	364.0	351.0	349.0	339.0	324.0	305.0	286.5	266.5	250.5	228.0	200.0	172.0
VS 78/13	●	75	100	393.5	393.0	356.0	377.0	366.0	349.5	329.5	309.5	287.5	270.0	245.5	215.0	185.0
VS 78/14	●	93	125	425.5	425.0	417.5	408.0	396.0	378.0	356.5	335.0	311.0	292.5	266.0	233.5	201.0
VS 78/15	●	93	125	455.5	454.5	446.0	436.0	423.0	404.0	381.0	357.5	333.0	312.0	284.0	249.0	214.0
VS 78/16	●	93	125	484.0	483.5	474.5	464.0	450.0	429.5	405.0	380.0	353.0	331.5	301.0	264.0	226.5

● = Pump available in R version (AISI 904L)

VS 97

Pump model	R vers.	RATED POWER		Q = DELIVERY										
				m ³ /h 0	15	30	45	60	75	90	105	120	135	150
				l/min 0	250	500	750	1000	1250	1500	1500	2000	2250	2500
[kW]	[HP]	H = TOTAL HEAD METERS COLUMN OF WATER [m]												
VS 97/2	●	15	20	64,5	64,0	62,5	59,5	54,5	49,5	45,0	42,0	37,0	30,0	23,0
VS 97/3	●	22	30	96,5	96,0	93,0	88,5	81,0	74,0	67,0	62,5	54,5	44,5	33,5
VS 97/4	●	30	40	129,5	129,0	125,0	119,0	109,5	99,5	91,0	85,0	74,0	61,0	46,5
VS 97/5	●	37	50	160,5	160,0	155,5	148,0	135,5	126,5	112,5	105,0	91,5	75,0	56,5
VS 97/6	●	37	50	190,5	190,0	184,0	174,5	160,0	154,5	132,5	123,0	106,5	86,5	65,0
VS 97/7	●	45	60	223,0	222,5	216,0	205,0	188,0	171,0	156,0	145,0	126,0	103,0	77,0
VS 97/8	●	55	75	261,5	261,0	254,0	242,0	222,5	203,0	185,5	173,5	152,5	126,0	97,0
VS 97/9	●	75	100	296,5	296,0	289,0	275,5	253,5	231,5	212,0	198,5	175,0	145,0	112,0
VS 97/10	●	75	100	328,5	328,0	320,0	305,0	280,5	256,0	234,0	219,0	193,0	159,5	123,5
VS 97/11	●	75	100	360,5	360,0	350,5	334,0	307,0	280,0	256,0	239,5	211,0	174,0	134,0
VS 97/12	●	93	125	394,5	394,0	384,0	366,0	336,5	307,0	281,0	263,0	231,0	191,5	148,0
VS 97/13	●	93	125	426,0	425,5	414,5	395,5	363,0	331,5	303,0	283,5	249,0	206,0	159,0
VS 97/14	●	93	125	457,5	457,0	445,0	424,0	389,5	355,5	324,5	303,5	266,5	220,0	169,0
VS 97/15		110	150	492,5	492,0	479,0	457,0	420,0	383,5	350,5	328,0	288,5	238,5	184,0
VS 97/16		110	150	523,5	523,0	509,5	486,0	446,5	407,5	372,0	348,0	306,0	253,0	195,0

● = Pump available in R version (AISI 904L)

VS 78 - TECHNICAL DATA 60 HZ

PUMPS WITH ENCAPSULATED MOTOR

Pump model	Motor			Dimensions [mm]					Pump weight [kg]
	Type	[kW]	[HP]	L1	L2	Lt	D		
							1 cable	2 cable	
VS 78/2	E6	11	15	644	711	1355	186.5	192	82.5
VS 78/3		18.5	25	770	841.5	1611.5	186.5	192	100
VS 78/4		22	30	896	906.5	1802.5	186.5	192	111
VS 78/5		30	40	1022	1036.5	2058.5	186.5	192	130
VS 78/6		37	50	1148	1421.5	2569.5	186.5	192	189
VS 78/7		37	50	1274	1421.5	2695.5	186.5	192	194
VS 78/8		45	60	1400	1574	2974	186.5	192	213
VS 78/9		E8	55	75	1531	1204	2735	195	197.5
VS 78/10	55		75	1657	1204	2861	195	197.5	247
VS 78/11	75		100	1783	1395	3178	195	197.5	290
VS 78/12	75		100	1909	1395	3304	195	197.5	295
VS 78/13	75		100	2035	1395	3430	195	197.5	300
VS 78/14	93		125	2161	1747	3908	195	197.5	383
VS 78/15	93		125	2287	1747	4034	195	197.5	388
VS 78/16	93		125	2413	1747	4160	195	197.5	392.5

PUMPS WITH REWINDABLE MOTOR

Pump model	R vers.	Motor			Dimensions [mm]					Pump weight [kg]
		Type	[kW]	[HP]	L1	L2	Lt	D		
								1 cable	2 cable	
VS 78/2	●	RW6	11	15	644	779	1423	186.5	192	87.5
VS 78/3	●		18.5	25	770	919	1689	186.5	192	106.5
VS 78/4	●		22	30	896	1009	1905	186.5	192	120.5
VS 78/5	●		30	40	1022	1214	2236	186.5	192	146
VS 78/6	●		37	50	1148	1294	2442	186.5	192	158
VS 78/7	●		37	50	1274	1294	2568	186.5	192	163
VS 78/8	●		RW8	45	60	1400	1230	2630	195	197.5
VS 78/9	●	55		75	1531	1340	2871	195	197.5	246
VS 78/10	●	55		75	1657	1340	2997	195	197.5	251
VS 78/11	●	75		100	1783	1560	3343	195	197.5	292
VS 78/12	●	75		100	1909	1560	3469	195	197.5	297
VS 78/13	●	75		100	2035	1560	3595	195	197.5	302
VS 78/14	●	93		125	2161	1740	3901	195	197.5	339
VS 78/15	●	93		125	2287	1740	4027	195	197.5	344
VS 78/16	●	93	125	2413	1740	4153	195	197.5	348.5	

● = Pump available in R version (AISI 904L)

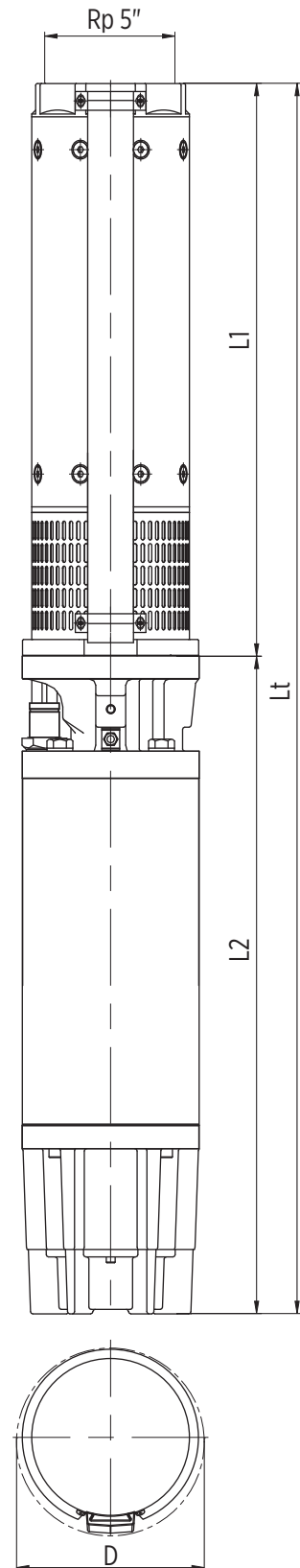

00730060 09/2017

VS 78 - PERFORMANCE CURVES 60 HZ

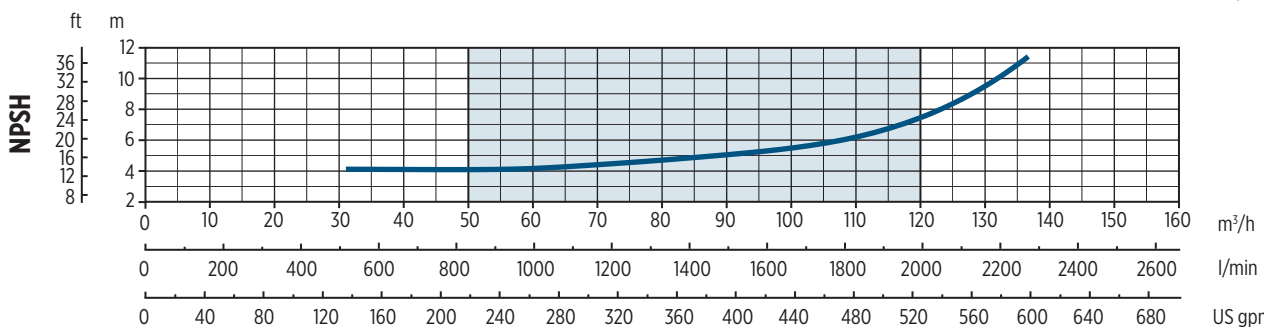
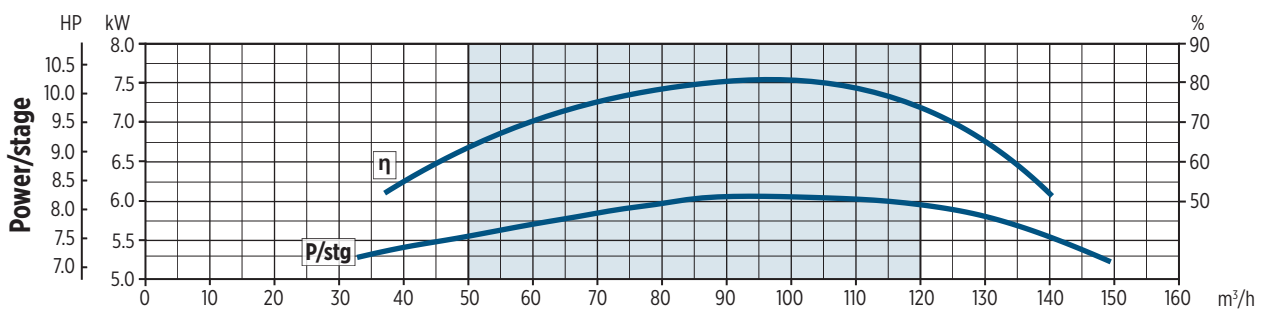
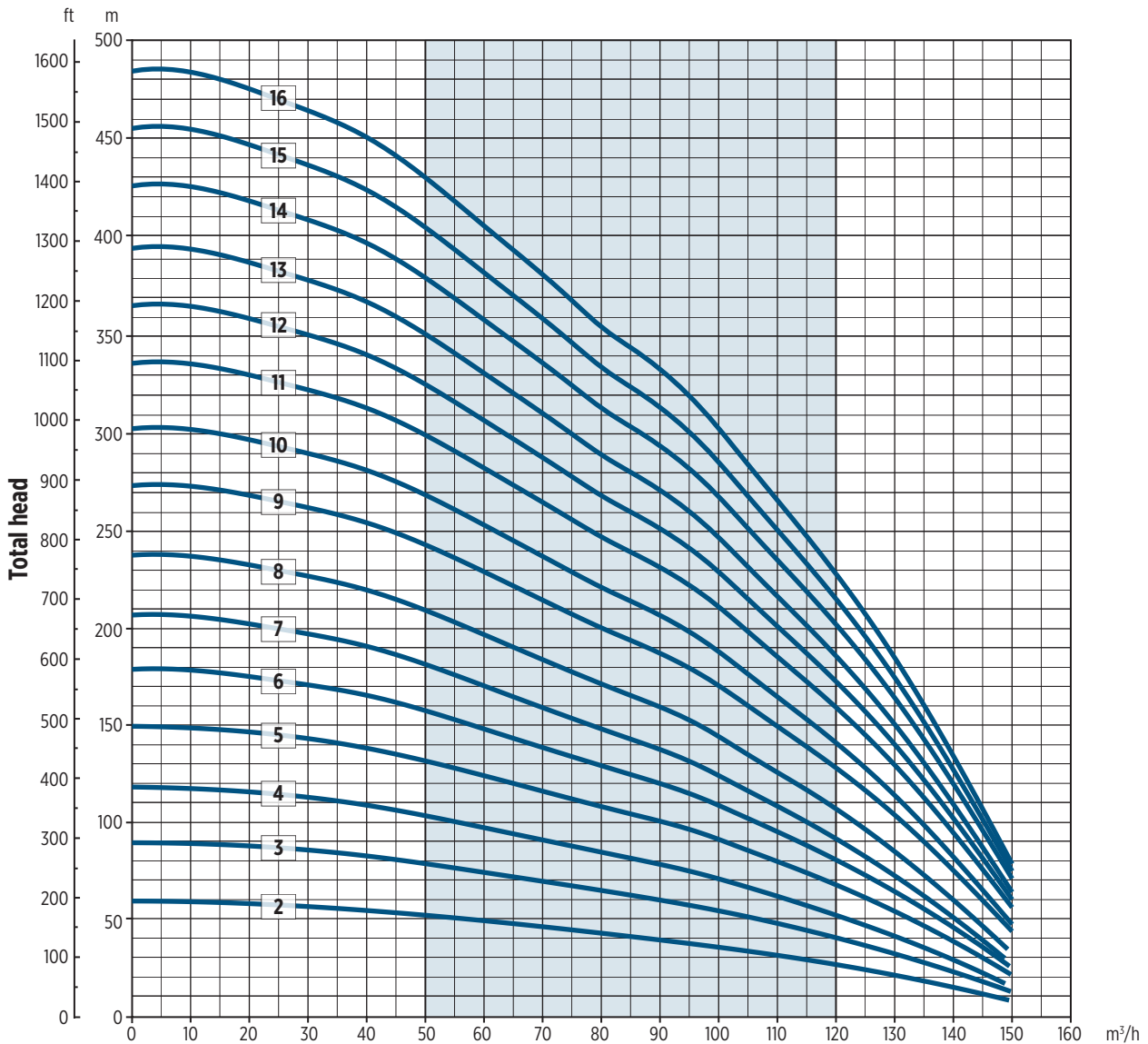

The hydraulic characteristics are guaranteed, according to ISO standard 9906:2012, grade 3B

00T0166EN 09/2018

VS 97 - TECHNICAL DATA 60 HZ

PUMPS WITH ENCAPSULATED MOTOR

Pump model	Motor			Dimensions [mm]					Pump weight [kg]
	Type	[kW]	[HP]	L1	L2	Lt	D		
							1 cable	2 cable	
VS 97/2	E6	15	20	644	776	1420	186.5	192	88
VS 97/3		22	30	770	906.5	1676.5	186.5	192	106
VS 97/4		30	40	896	1036.5	1932.5	186.5	192	125.5
VS 97/5		37	50	1022	1421.5	2443.5	186.5	192	184
VS 97/6		37	50	1148	1421.5	2569.5	186.5	192	189
VS 97/7		45	60	1274	1574	2848	186.5	192	208
VS 97/8	E8	55	75	1405	1204	2609	195	197.5	237.5
VS 97/9		75	100	1531	1395	2926	195	197.5	280
VS 97/10		75	100	1657	1395	3052	195	197.5	285
VS 97/11		75	100	1783	1395	3178	195	197.5	290
VS 97/12		93	125	1909	1747	3656	195	197.5	373
VS 97/13		93	125	2035	1747	3782	195	197.5	378
VS 97/14		93	125	2161	1747	3908	195	197.5	383
VS 97/15		110	150	2287	1975.5	4262.5	195	197.5	431
VS 97/16		110	150	2413	1975.5	4388.5	195	197.5	435.5

PUMPS WITH REWINDABLE MOTOR

Pump model	R vers.	Motor			Dimensions [mm]					Pump weight [kg]
		Type	[kW]	[HP]	L1	L2	Lt	D		
								1 cable	2 cable	
VS 97/2	●	RW6	15	20	644	874	1518	186.5	192	97.5
VS 97/3	●		22	30	770	1009	1779	186.5	192	115.5
VS 97/4	●		30	40	896	1214	2110	186.5	192	141.5
VS 97/5	●		37	50	1022	1294	2316	186.5	192	153
VS 97/6	●		37	50	1148	1294	2442	186.5	192	158
VS 97/7	●		45	60	1274	1230	2504	195	197.5	212
VS 97/8	●	RW8	55	75	1405	1340	2745	195	197.5	241.5
VS 97/9	●		75	100	1531	1560	3091	195	197.5	282
VS 97/10	●		75	100	1657	1560	3217	195	197.5	287
VS 97/11	●		75	100	1783	1560	3343	195	197.5	292
VS 97/12	●		93	125	1909	1740	3649	195	197.5	329
VS 97/13	●		93	125	2035	1740	3775	195	197.5	334
VS 97/14	●		93	125	2161	1740	3901	195	197.5	339

● = Pump available in R version (AISI 904L)

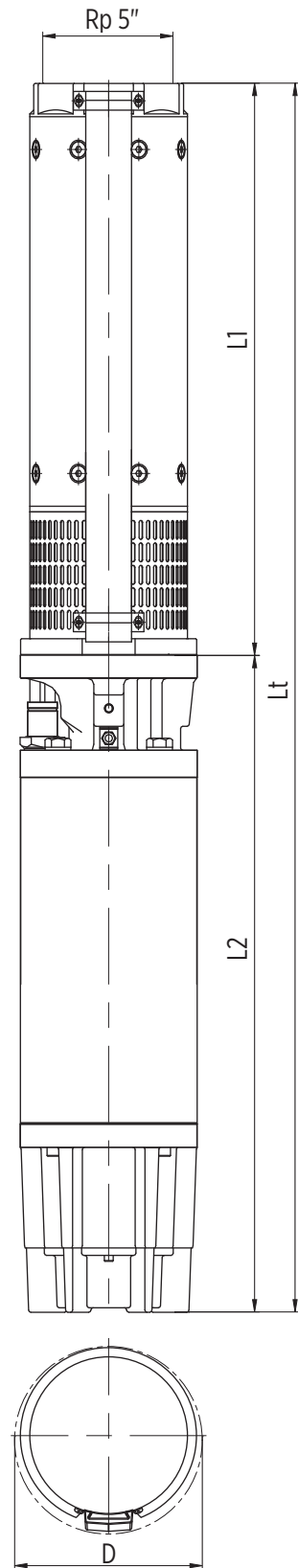

00730060 09/2017

VS 97 - PERFORMANCE CURVES 60 HZ

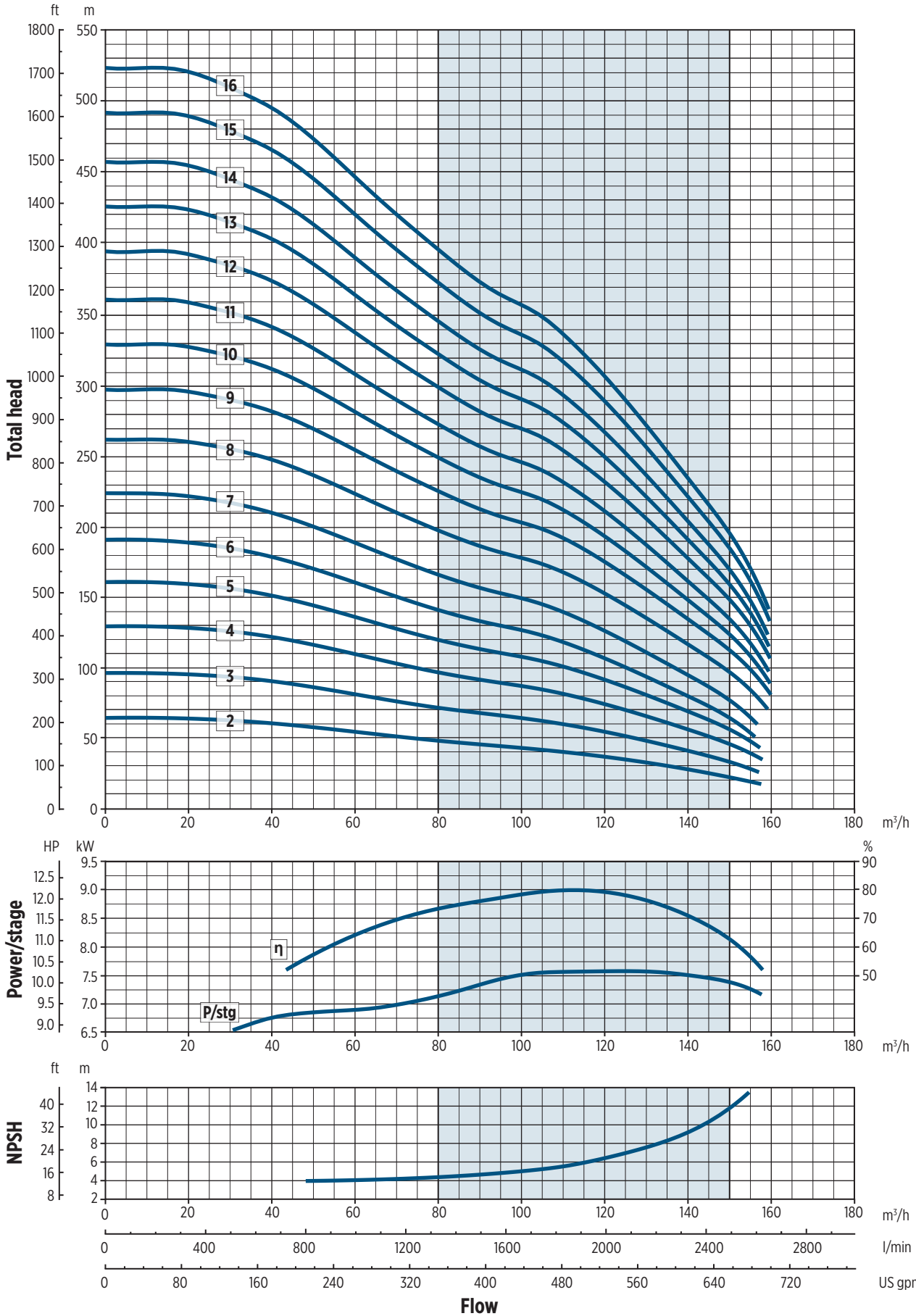

SPARE PARTS

VS 78-97

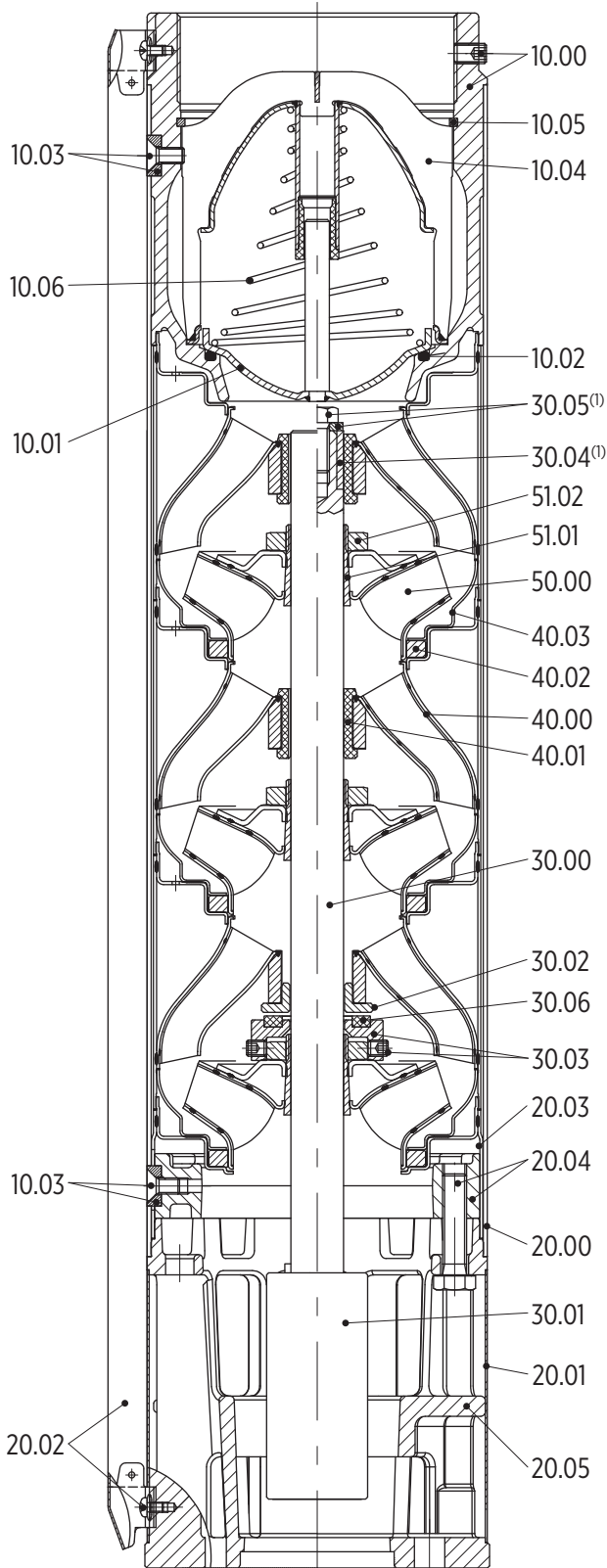

Ref. N.	Description
10.00	Discharge head
10.01	Valve
10.02	Sealing O-ring
10.03	Outer case locking nuts
10.04	Valve support
10.05	Seeger ring
20.00	Outer case
20.01	Suction strainer
20.02	Cable guard and screws
20.03	Initial spacer
20.04	Flange
	Screws
20.05	Motor adapter
30.00	Pump shaft
30.01	Coupling
30.02	Upper up-thrustwasher
30.03	Lower up-thrust washer
30.04	Upper journal sleeve ¹⁾
30.05	Screw and washer ¹⁾
30.06	Up-thrust ring
40.00	Diffuser
40.01	Secondary bearing bush
40.02	Floating neck ring
40.03	Flange clamping neck ring
50.00	Impeller
51.01	Split cone
51.02	Split cone nut

1) only for types with more than 8 stages

0030061 09/2017



MOTOR ADAPTER AND DIMENSIONS

VS 78-97

4" MOTOR ADAPTER FOR I AND N VERSION

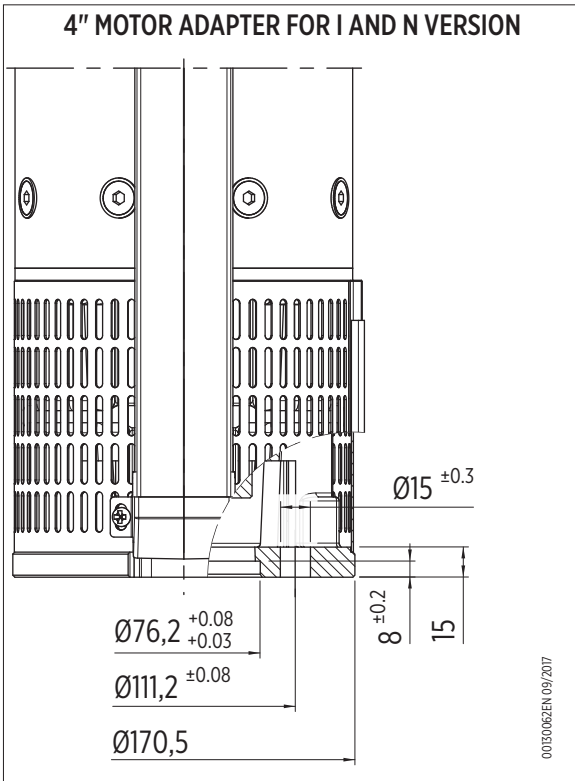

6" MOTOR ADAPTER FOR I, N AND R VERSION

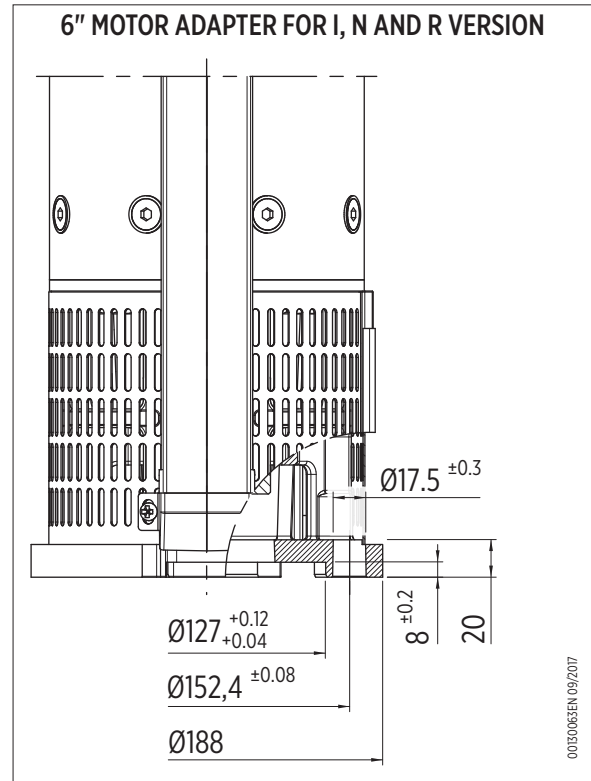

CATALOG REVISION CHANGES NOTICE

Rev. No.	Changes	Page
01	General updating of all catalog	All
02	Added notes for 4" motor adapter	14, 20, 24, 28
	Updated general descriptions	4-46
	Updated "Pump identification code"	5, 47
	Updated "Material/fluids compatibility" tables	6, 48
	Updated "Spare parts" list (VS 6")	40, 41
	Added VS25 model	4,5,6,9,24,25, 40-43





Franklin Electric

Franklin Electric S.r.l.
Via Asolo, 7 - 36031 Dueville (Vicenza) - ITALY
Phone: +39 0444 361114 - Fax: +39 0444 365247
Email: sales.it@fele.com

Single member - Company subject to the control and coordination of Franklin Electric Co., Inc.

Franklin Electric S.r.l. reserves the right to amend specification without prior notice

franklinwater.eu

00103920 EN_REV.02_06/2021