

Kiekis	Aprašymas
--------	-----------

1	<b>ALPHA2 25-60 N 180</b>
---	---------------------------



Atkreipkite dėmesį! Paveikslėlyje parodytas produktas gali skirtis nuo tikrojo

Produkto Nr.: [99411424](#)

Grundfos ALPHA2 high-efficiency circulator pumps are designed for circulating liquids in heating systems. The stainless-steel variant of the ALPHA2 is suitable for e.g. domestic hot-water systems. With an energy efficiency index (EEI) well below the ErP benchmark, it ensures substantial energy savings.

The AUTOADAPT function continuously adapts the pump performance to the actual heat demand, i.e. the size of the system and changing heat demand during the year.

The AUTOADAPT feature finds the setting that provides optimal comfort with minimal energy consumption and makes the commissioning fast, safe, and easy.

ALPHA2 also offers proportional-pressure, constant-pressure and constant-curve control modes.

With the automatic night setback function, the pump automatically changes between normal duty and night setback.

The changeover depends on the flow-pipe temperature controlled by the heating appliance.

In manual summer mode, the pump does not operate but starts automatically at low speed to avoid blocking the rotor as well as sticky valves and non-return valves.

Control modes and functions are selected using the buttons on the display. The LEDs indicate the operating status, actual power consumption in watt or actual flow rate in m<sup>3</sup>/h as well as warnings and alarms.

Furthermore, ALPHA2 is compatible with ALPHA Reader and the Grundfos GO Balance app, enabling installers to perform easy hydronic balancing of radiator- and underfloor-heating systems.

The design and chosen materials of the pump contribute to long life.

The pump is self-venting through the system, which contributes to easy commissioning.

The compact design, featuring a pump head with an integrated control box, fits into most common installations.

Pump and motor form an integral unit without a shaft seal.

The bearings are lubricated by the pumped liquid.

These constructional features ensure maintenance-free operation.

The active dry-running protection feature protects the pump against dry running during startup and normal operation. In case of a blocked rotor, the pump will continuously attempt to restart with highest possible torque.

Pump housings made of cast iron are electrocoated to improve corrosion resistance. The motor is a synchronous permanent-magnet/compact-stator motor characterised by high efficiency. The pump speed is controlled by an integrated frequency converter incorporated in the control box.

Insulating shells are supplied with pumps to minimise heat loss in heating systems.

# 99411424 ALPHA2 25-60 N 180

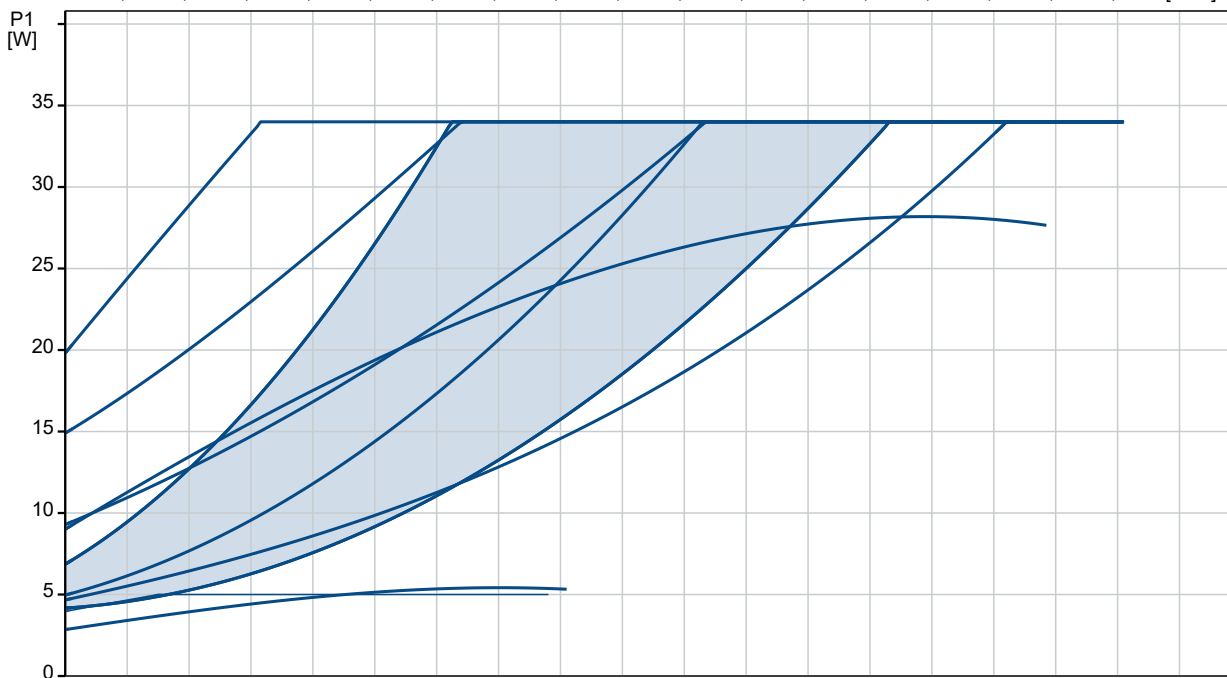
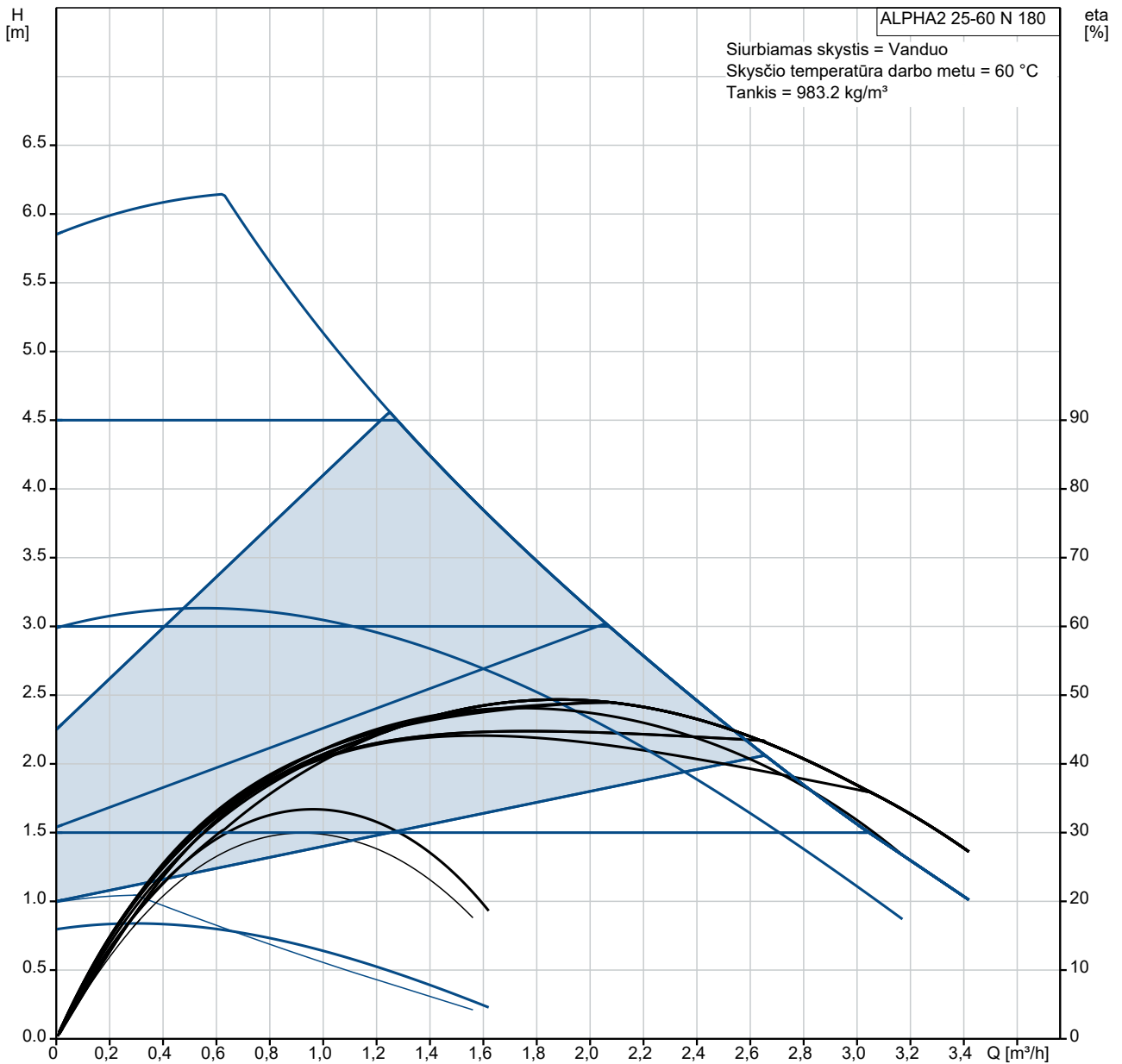

Aprašymas	Vertė
<b>Bendra informacija:</b>	
Produkto pavadinimas:	ALPHA2 25-60 N 180
Produkto Nr.:	99411424
EAN numeris:	5713828679895
Kaina:	€ 761.6
<b>Techniniai duomenys:</b>	
Maks. slėgio aukštis:	60 dm
TF klasė:	110
Sertifikatai ant vardinės plokštelės:	CE,VDE,EAC,RCM
Modelis:	E
<b>Medžiagos:</b>	
Siurblio korpusas:	Nerūdijantis plienas
Siurblio korpusas:	EN 1.4308
Siurblio korpusas:	ASTM 351 CF8
Darbaratis:	PES 30%GF
<b>Įrengimas:</b>	
Aplinkos temperatūros intervalas:	0 .. 40 °C
Maksimalus darbinis slėgis:	10 bar
Vamzdžio jungtis:	G 1 1/2
Slėgis:	PN 10
Montažinis ilgis:	180 mm
<b>Skystis:</b>	
Siurbiamas skystis:	Vanduo
Skysčio temperatūros diapazonas:	2 .. 110 °C
Skysčio temperatūra eksploataavimo metu:	60 °C
Tankis:	983.2 kg/m <sup>3</sup>
<b>Elektrotechniniai duomenys:</b>	
Naudojama galia P1:	3 .. 34 W
Elektros tinklo dažnis:	50 / 60 Hz
Nominali įtampa:	1 x 230 V
Maksimali vartojama srovė:	0.04 .. 0.32 A
Korpuso klasė (IEC 34-5):	X4D
Izoliacijos klasė (IEC 85):	F
Integruota variklio apsauga:	NĖRA
Šiluminė apsauga:	ELEC
<b>Valdikliai:</b>	
Automatinis naktinis režimas:	su automatinio naktiniu režimu
Kontaktų dėžutės padėtis:	6H
<b>Kita:</b>	
Energija (EEL):	0.17
Neto masė:	2.21 kg
Bendra masė:	2.37 kg
Transportavimo tūris:	0.004 m <sup>3</sup>
Danijos VVS Nr.:	380463160
Švedijos RSK Nr.:	5790516
Suomijos LVI Nr.:	4615349
Norvegijos NRF Nr.:	9043166
Kilmės šalis:	DK
Muitinės kodas:	84137030

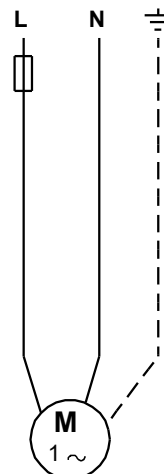
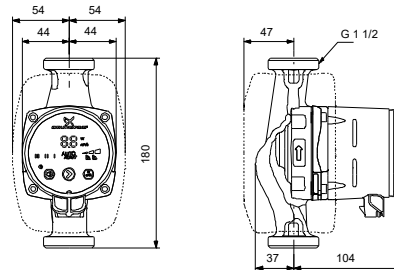
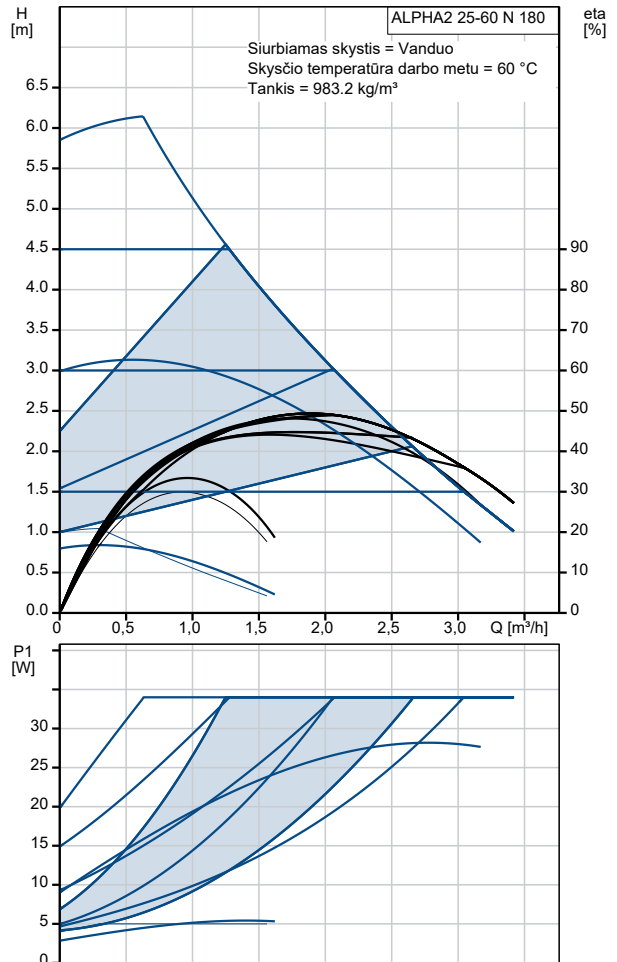

# 99411424 ALPHA2 25-60 N 180

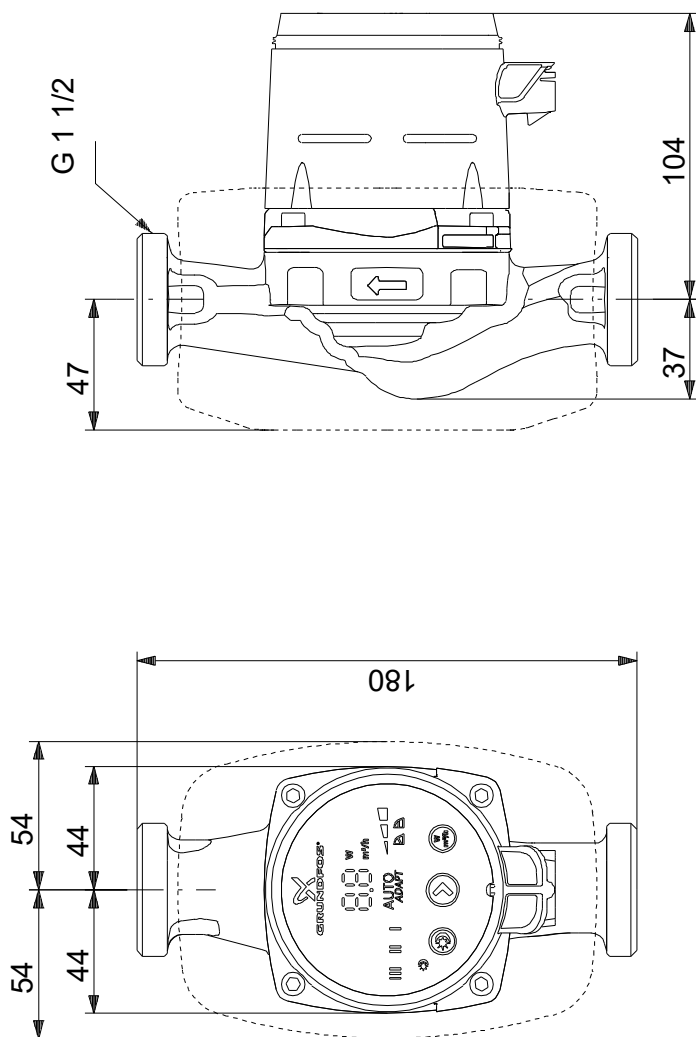

Atkreipkite dėmesį! Visi matmenys, jei nenurodyta kitaip, pateikti milimetrais.  
Atsakomybės apribojimas: šiame supaprastintame matmenų brėžinyje neparodytos visos detalės.

99411424 ALPHA2 25-60 N 180

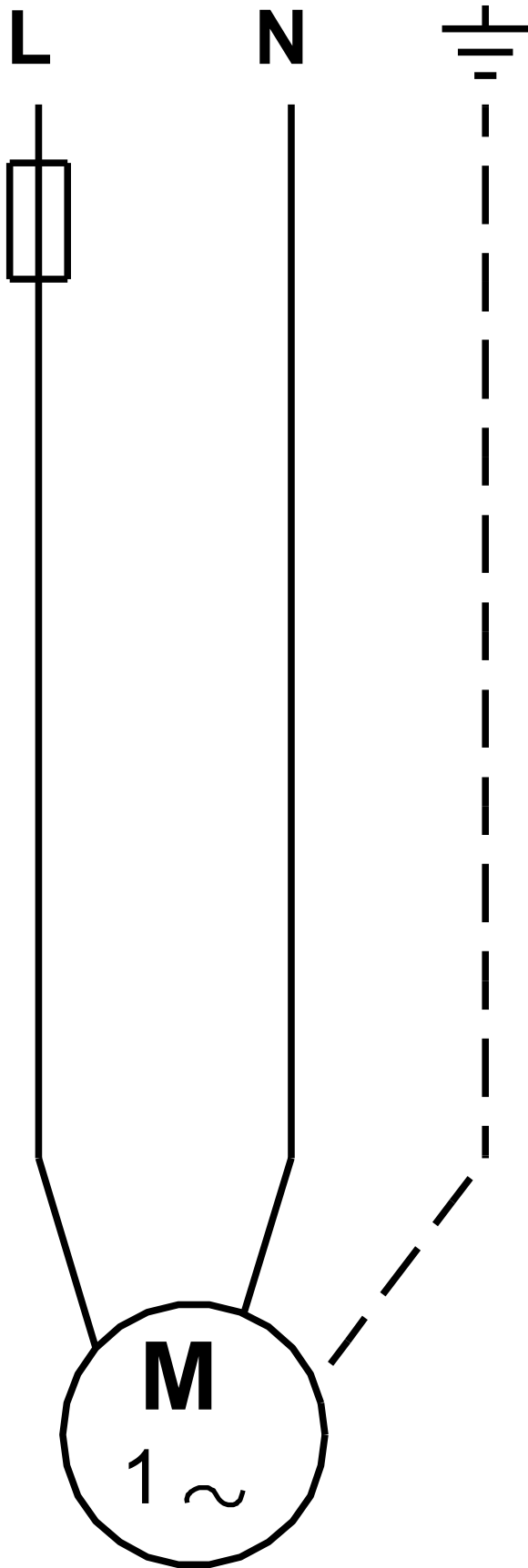

Atkreipkite dėmesį! Visi matmenys, jei nenurodyta kitaip, pateikti milimetrais.