

V4

SUBMERSIBLE PUMPS



Elettropompe sommergibili con girante Vortex

Submersible electropumps with Vortex impeller

Potenze / Power:	1.1÷7.5 kW
Mandate / Delivery:	DN 65 - 80 - 100



Impieghi

La serie VT 4 poli trova impiego nel pompaggio nella movimentazione di liquidi fognari particolarmente pesanti. Alte prestazioni e ampi passaggi rendono la serie adatta ad essere impiegata nell'industria, nella zootecnia, sul convogliamento di fanghi, concreie, ed ovunque ci sia la necessità di pompare liquidi con pezzi solidi di grandi dimensioni.

Caratteristiche

Tutti i componenti principali sono realizzati in Ghisa GG25. Due tenute meccaniche separate (lato motore a bagno olio, lato girante a contatto con il liquido) e componentistica di prima qualità, ne garantiscono il perfetto funzionamento.

Motori

- Motori asincroni 4 poli con rotore a gabbia di scoiattolo
- Protezione termica T1 e T2 incorporato nel motore da collegare ad un apposito quadro di comando
- Isolamento statore classe F (155°C)
- Grado protezione IP 68

Raffreddamento

Raffreddamento effettuato dal liquido nel quale la pompa è immersa.

Limiti di impiego

- Temperatura massima del liquido: 40°C con unità completamente sommersa
- Disponibili versioni speciali (escluso ATEX) fino alla temperatura liquido di 60°C con unità completamente sommersa, non a servizio continuo (S1)
- Massima profondità di immersione: 20m
- Valori pH ammessi: 6-10
- Caratteristiche idrauliche valide per liquidi di densità <1,1 kg/dm³
- Tensioni ammesse: 230/400V o 400/690V ±5% a seconda del modello
- Frequenza ammessa: 50Hz ±2%

Application

The VT 4 poles Series is used for transport of water with heavy suspended solids. High performance and a wide channel permits its use in industry, including tanneries and farms, and for the movement of water contaminated with soil, or containing large solid pieces.

Characteristic

All main components are made of grey cast iron GG25. Two individual mechanical seals (motor side in the oil chamber, impeller side in contact with the liquid) and high quality parts, ensure the perfect functioning and reliability of the product.

Motor range

- Squirrel cage motor 4 poles
- Thermal protection T1 and T2 embedded in the motor winding (to be wired to the three pole contactor in the control panel)
- Class F insulation (155°C)
- IP 68 protection

Motor cooling

The cooling of the motor is ensured by the liquid where the pump is submerged.

Limits of use

- Max. permissible liquid temperature: 40°C with pump fully submerged
- On request, special version (excluded ATEX) to withstand liquid temperature up to 60°C with pump fully submerged, no S1 service
- Maximum depth of immersion: 20 mt
- Permissible pH value: 6-10
- Hydraulic features suitable for liquids with density <1,1 kg/dm³
- Allowed voltage: 230/400V or 400/690V ±5% depending on the pump
- Allowed frequency: 50Hz ±2%

Designazione / Designation

VT-EX 80 / 4 / 173 C.356

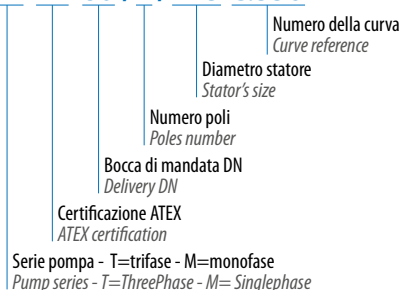

Campo di Prestazione / Performance Overview

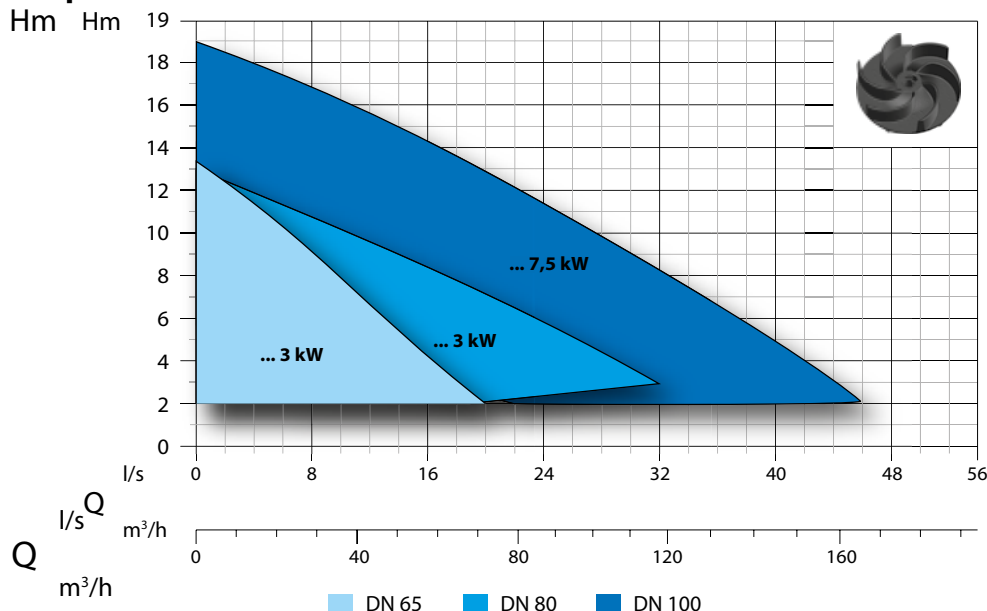

Identificazione Curve

Curves Identification

- DN 65
- DN 80
- DN 100

Normative

Norms

Curve secondo ISO 9906:2012 3B2
According to ISO 9906:2012 3B2

Distinta dei componenti e materiali List of components and materials

V4

Anello catena - Chain ring

Acciaio inox AISI 416 - Stainless steel AISI 416

Cassa motore - Motor casing

Ghisa GG25 - Cast iron GG25

Cuscinetto superiore - Upper bearing

Albero motore - Motor shaft

Acciaio inox AISI 420 - Stainless steel AISI 420

Motore elettrico - Electric motor

Rotore - Rotor

Cuscinetto inferiore - Lower bearing

Porta motore - Motor holder

Ghisa GG25 - Cast iron GG25

Tenuta meccanica - Mechanical seal

Ceramica/Grafite - Carbon/Ceramic (CA/CE/Viton)

Porta motore - Motor holder

Ghisa GG25 - Cast iron GG25

Tenuta meccanica - Mechanical seal

Carburo di silicio - Silicon/Carbide (SiC/SiC/Viton)

Corpo pompa - Body pump

Ghisa GG25 - Cast iron GG25

Girante - Impeller

Ghisa GG25 - Cast iron GG25

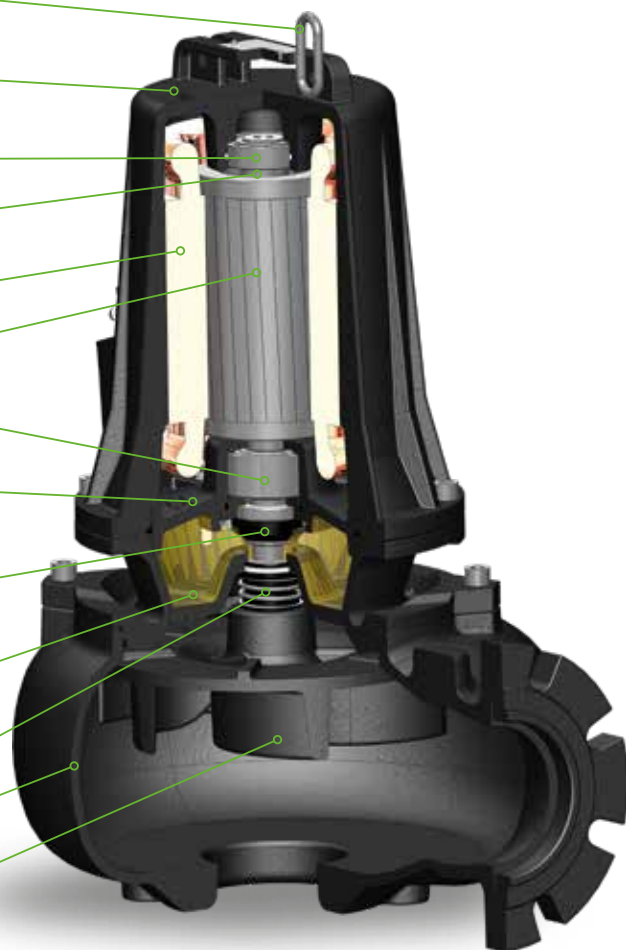

Tecnologie e Soluzioni Technology and Features

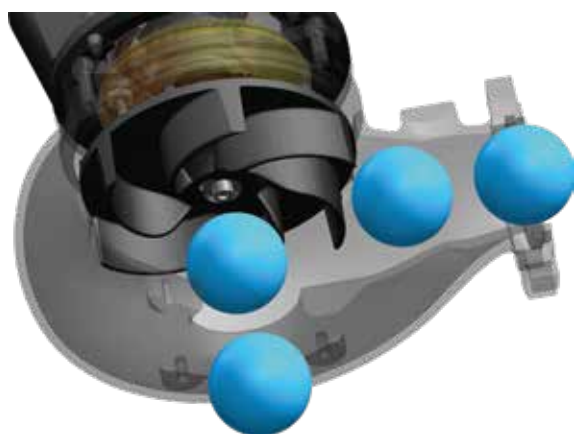

Giranti

Giranti Vortex sviluppati per garantire sempre il miglior compromesso tra prestazioni e passaggio di corpi solidi: ciò elimina completamente la possibilità di intasamento.

Impellers

Impellers have been studied to grant excellent performances and ample solid handling.



Pompe antideflagranti / Explosion proof pumps



EPT 17 ATEX 2702 X



II 2G Ex db IIB T4 Gb
Ex h IIB T4 Gb
0° ≤ Ta ≤ 40°

Tutta la serie è disponibile con certificato ATEX su richiesta
Pumps with explosion proof available on request.



Sensore d'umidità

Sensore conforme alle norme sulla sicurezza integrata contro le esplosioni ATEX EN 60079-0, EN 60079-1 tramite barriera di protezione. Di serie su tutta la gamma.

Seal leak detector

The seal leak detector is certified according to the norm ATEX EN 60079-0, EN 60079-1 (through safety barrier) and fitted standard on all series.



Pressacavo

Pressacavo pressofuso in acciaio inox, conforme alla normative: ATEX EN 60079-0, EN 60079-1 con linguetta anti-strappo. Standard su tutta la serie.

Cable gland

The cable gland is made of stainless steel AISI 316 and certified according to the norm ATEX EN 60079-0, EN 60079-1. Standard on all series.

Mandata Orizzontale DN65 PN10 - RPM 1450 1/min 4 poli

Horizontal Outlet DN65 PN10 - RPM 1450 1/min 4 poles

Immagine a solo scopo illustrativo
Picture for illustration purposes only



Curva di Prestazione

Performance Curve

L = rendimento massimo pompa
maximum pump efficiency

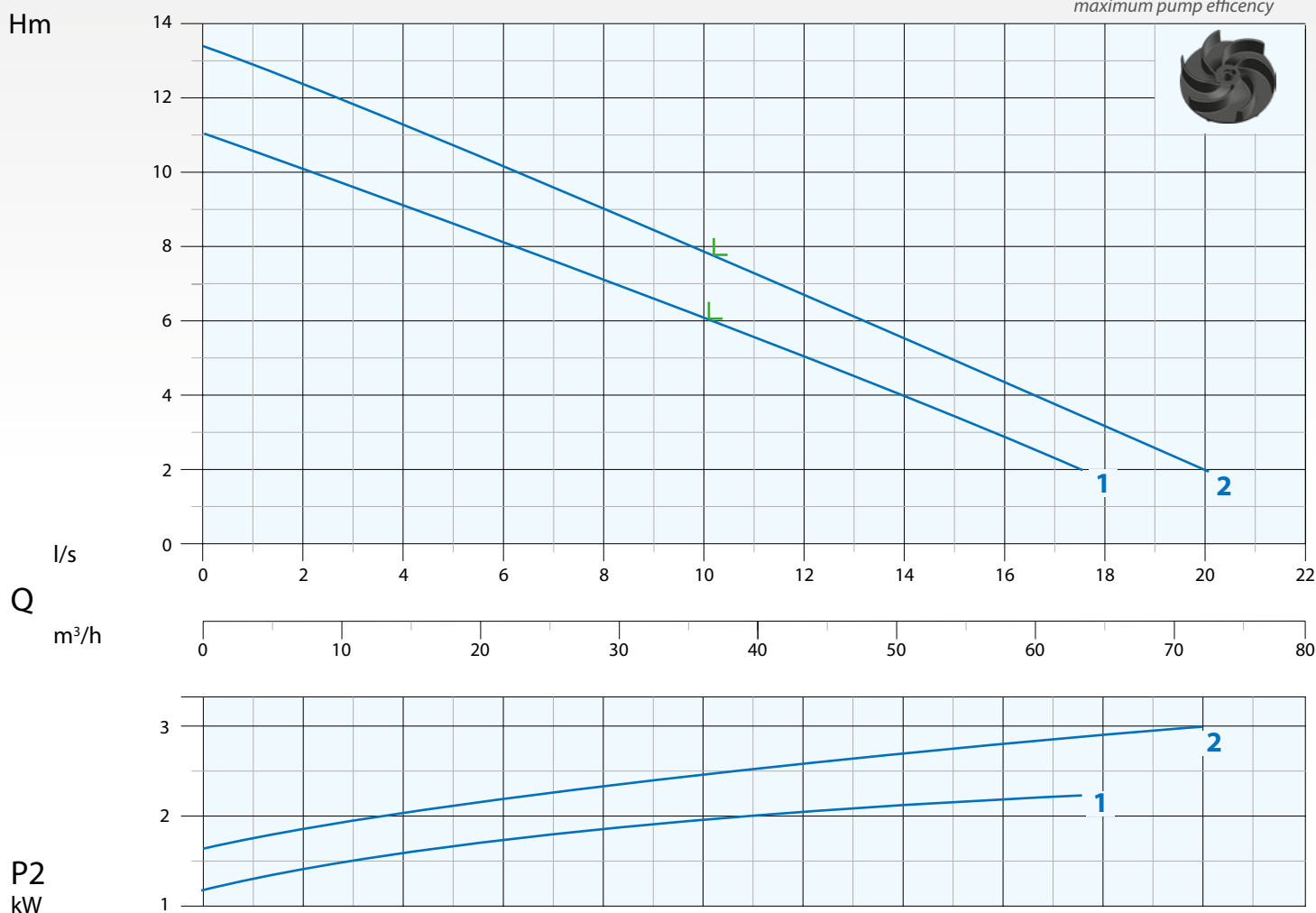

N°	Tipo Type	Flow Rate										
		l/s	2	4	6	8	10	12	14	16	18	20
		l/m	120	140	360	480	600	720	840	960	1080	1320
		m³/h	7,2	14,4	21,6	28,8	36,0	43,2	50,4	57,6	64,8	72
1	VT 65/4/152 C.344	mt	10	9	8,5	8	6	5	4	3		
2	VT 65/4/152 C.345		12,5	11,2	10,5	10	7,8	7,5	6,5	4,5	3	2

N°	Tipo Type	EX	Mandata Delivery	Passaggio Free Passage	kW		HP	R.P.M. 1/min	A 3 Phase - 400V	Hz
					P1	P2				
1	VT 65/4/152 C.344		DN65 PN10	65 mm	2,8	2,2	3	1450	5,2	50
2	VT 65/4/152 C.345				3,8	3	4		7,2	

V4

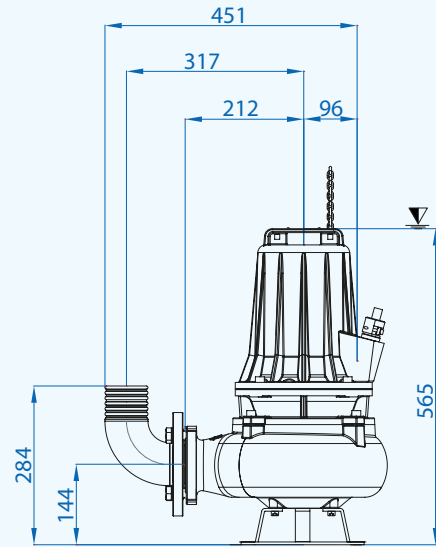
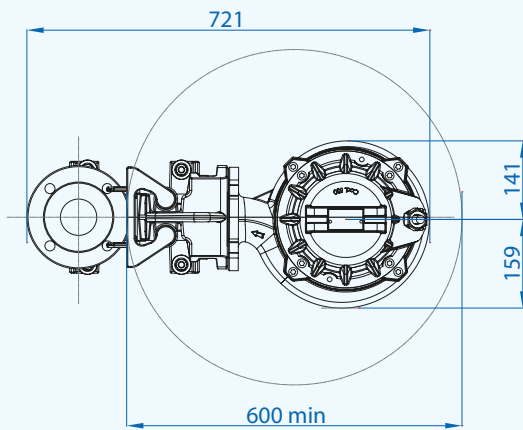
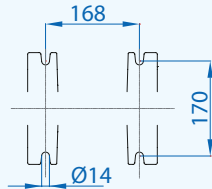
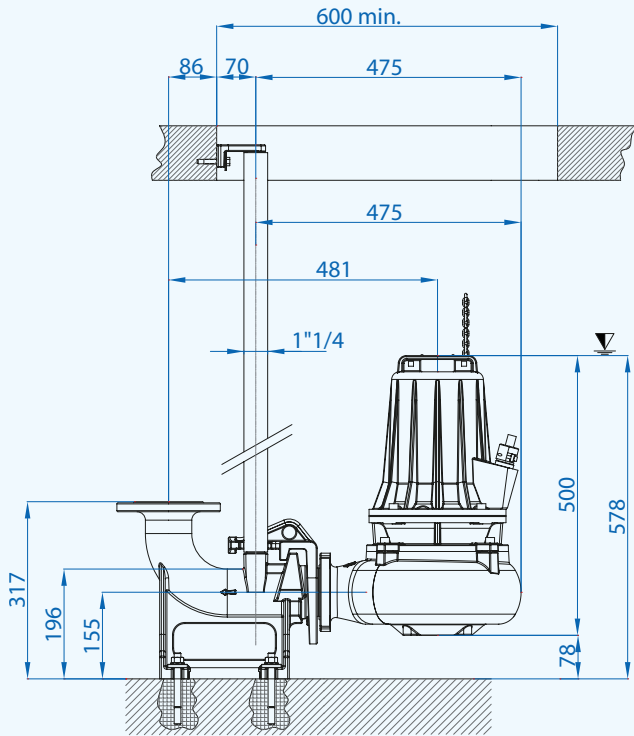

∇ Sommergenza minima
Minimum submersion

DN65 PN10
ex UNI 2278

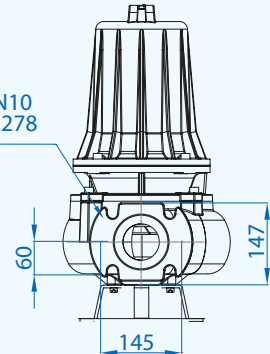

Quote in mm
Dimensions in mm

Cavi / Cables

Pompe Pumps	Fasi Phases	Cavo Cable	Sezione cavo mm ² Cable cross section mm ²	mt
65/4/152	3 ~ 400V D.O.L.	H07RN8F	4x1,5+3x0,50 Ø15*	10

* Terminali liberi - Free terminals

Dimensioni imballo / Packaging dimension

Tipo - Type	X mm	Y mm	Z mm	Kg
VT 65/4/152 C.344	355	580	420	66
VT 65/4/152 C.345				70

Accessori - Optional



Piede di accoppiamento
Tipo: DUTY 65 e B4 PN10
Automatic coupling foot
Type: DUTY 65 and B4 PN10



Curva flangiata con portagomma N5
Base di sostegno P4
Flanged hose connection N5
Foot support P4



Manico inox
Stainless steel handle

Mandata Orizzontale DN80 PN16 - RPM 1450 1/min 4 poli

Horizontal Outlet DN80 PN16 - RPM 1450 1/min 4 poles

Immagine a solo scopo illustrativo
Picture for illustration purposes only



Curva di Prestazione Performance Curve

L = rendimento massimo pompa
maximum pump efficiency

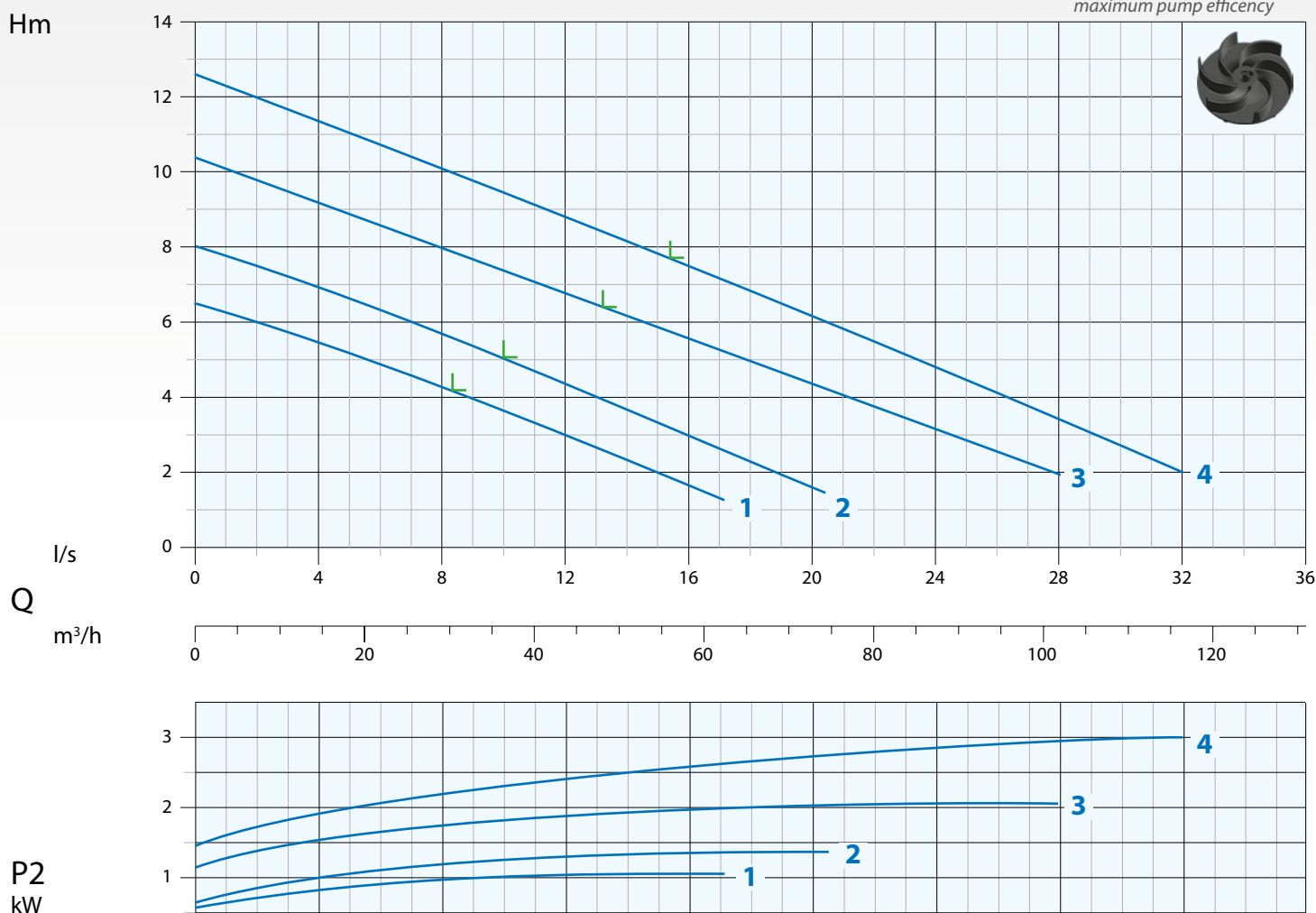

N°	Tipo Type	l/s	2	4	6	8	12	16	20	24	28	32
			l/m	240	360	480	720	960	1200	1440	1680	1920
		m³/h	7,2	14,4	21,6	28,8	43,2	57,6	72	86,4	100,8	115,2
1	VM-VT 80/4/125 C.341	mt	6	5,5	5	4,5	3	1,5				
2	VM-VT 80/4/125 C.342		7,5	7	6,5	5,5	4,5	3	1,5			
3	VT 80/4/152 C.344		9,5	9,2	8,5	8	6,8	5,5	4,5	3,2	2	
4	VT 80/4/152 C.345		12	11,5	10,5	10	8,8	7,5	6,2	4,8	3,5	2

N°	Tipo Type	EX	Mandata Delivery	Passaggio Free Passage	kW			R.P.M. 1/min	A		Hz
					P1	P2	HP		1 Phase - 230V	3 Phase - 400V	
1	VM-VT 80/4/125 C.341	•	DN80 PN16	75 mm	1,3	1,1	1,5	1450	7,3	45	2,8
2	VM-VT 80/4/125 C.342	•			1,7	1,25	1,7		8,7	45	3,3
3	VT 80/4/152 C.344	•		80 mm	2,8	2,2	3				5,2
4	VT 80/4/152 C.345	•			3,8	3	4				7,2

• Pompa antideflagrante disponibile con certificazione
Available explosion proof pump



EPT 17 ATEX 2702 X



Ex db IIB T4 Gb
Ex h IIB T4 Gb
0° ≤ Ta ≤ 40°

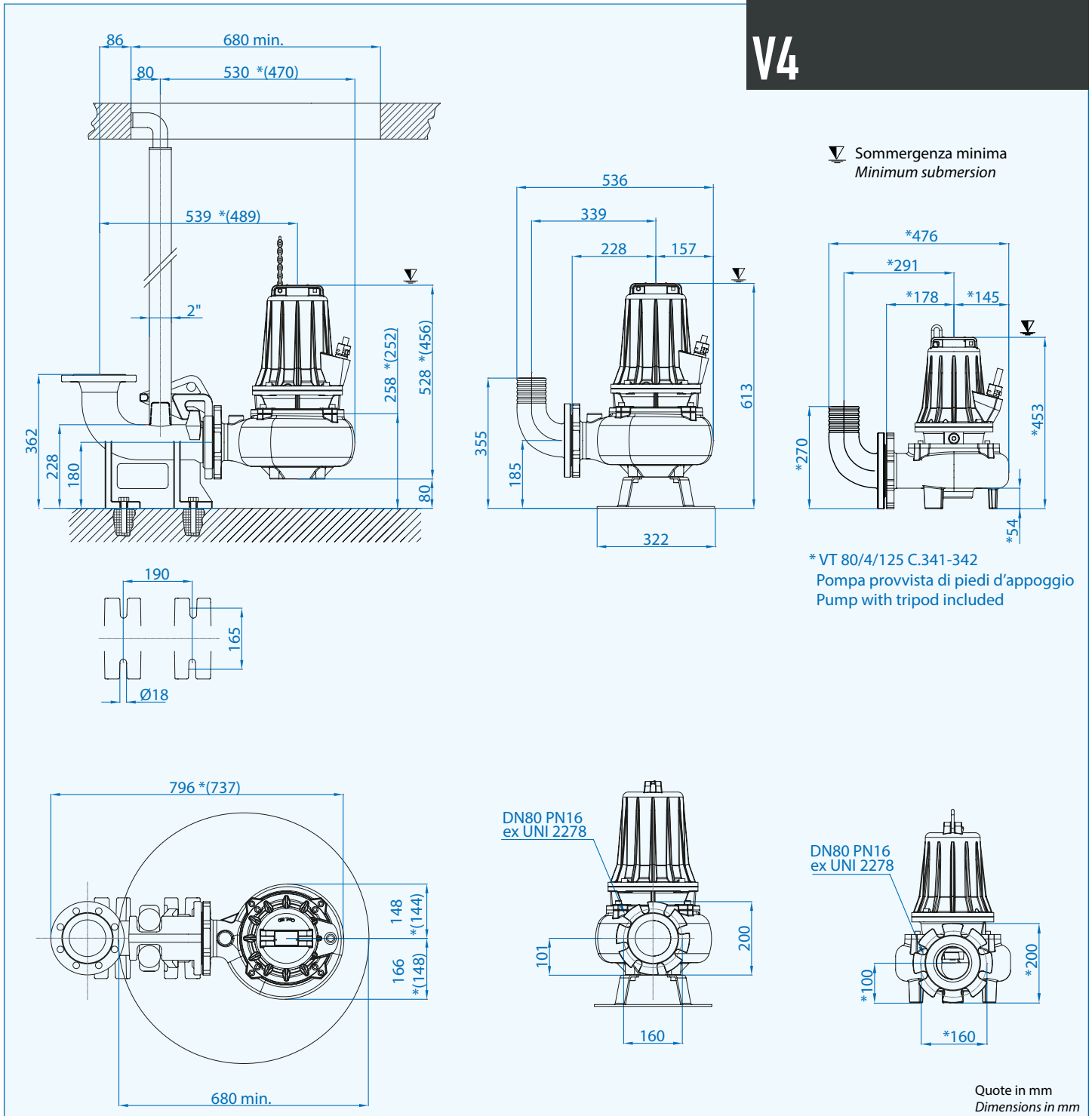

Cavi / Cables

Pompe Pumps	Versione Version	Fasi Phases	Cavo Cable	Sezione cavo mm ² Cable cross section mm ²	mt
80/4/125	Standard	1 ~ 230V	H07RN8F	4x1,5+3x0,50 Ø15*	10
	ATEX		NSSHÖU-J	4x1,5+3x0,50 Ø17*	10
	Standard	3 ~ 400V	H07RN8F	4x1,5+3x0,50 Ø15**	10
	ATEX		D.O.L.	NSSHÖU-J	4x1,5+3x0,50 Ø17**
80/4/152	Standard	3 ~ 400V	H07RN8F	4x1,5+3x0,50 Ø15**	10
	ATEX		D.O.L.	NSSHÖU-J	4x1,5+3x0,50 Ø17**

* Di serie con Control-box (condensatore di spunto compreso)
Standard with Control-box (starting capacitor included)

** Terminali liberi - Free terminals

Dimensioni imballo / Packaging dimension

Tipo - Type	X mm	Y mm	Z mm	Kg
VM-VT 80/4/125 C.341				48
VM-VT 80/4/125 C.342				48
VT 80/4/152 C.344	355	580	420	65
VT 80/4/152 C.345				66

Accessori - Optional



Quadri ATEX disponibili su richiesta
Explosion proof control box available on request

Mandata Orizzontale DN100 PN16 - RPM 1450 1/min 4 poli

Horizontal Outlet DN100 PN16 - RPM 1450 1/min 4 poles

Immagine a solo scopo illustrativo
Picture for illustration purposes only



Curva di Prestazione

Performance Curve

L = rendimento massimo pompa
maximum pump efficiency

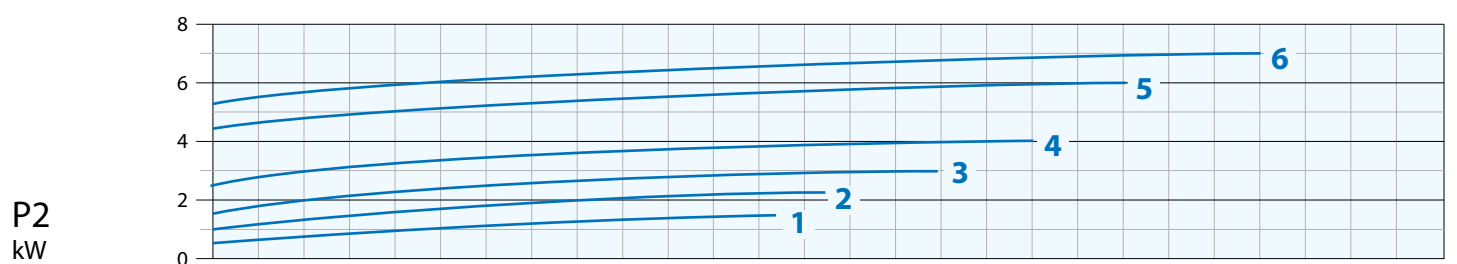
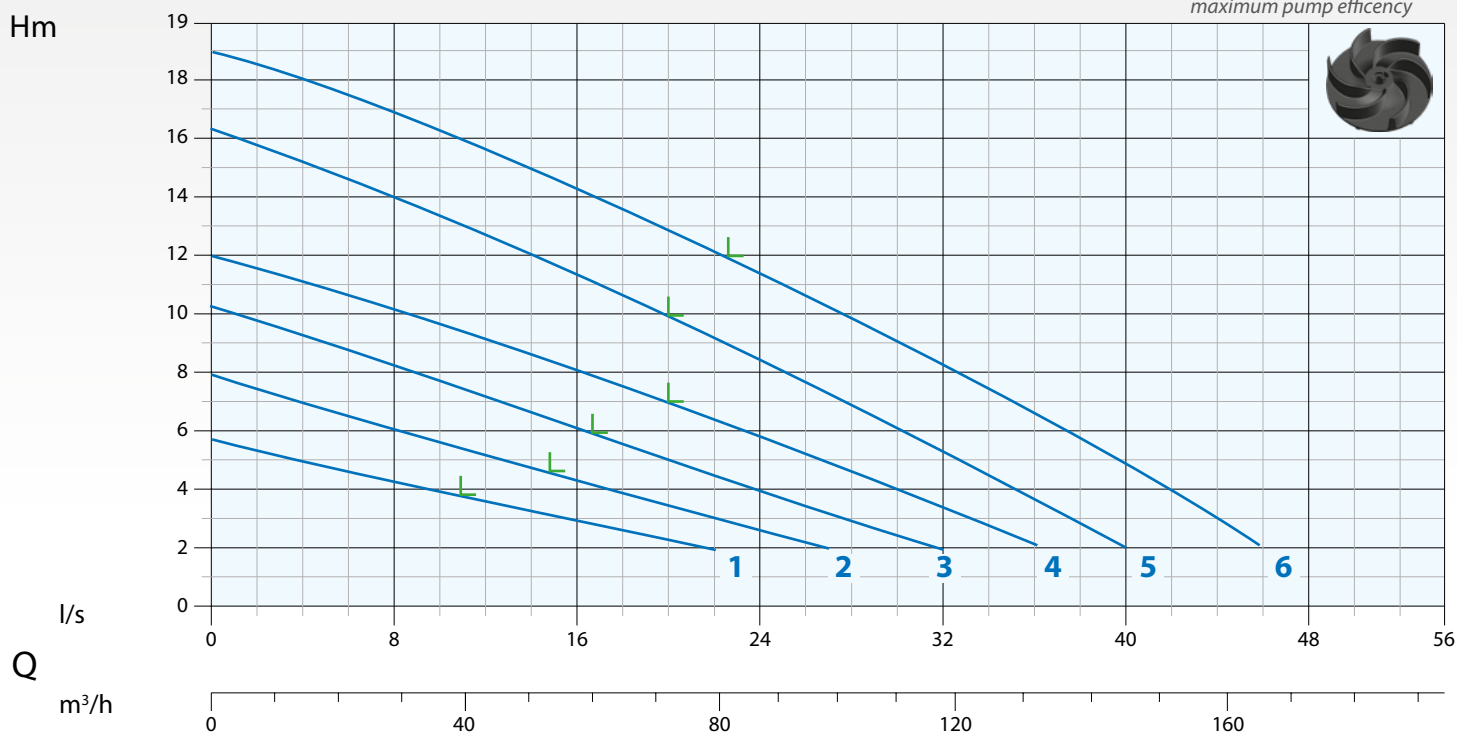

N°	Tipo Type	l/s	4	8	12	16	20	24	32	36	40	46
			l/m	480	720	960	1200	1440	1920	2160	2400	2760
		m³/h	14,4	28,8	43,2	57,6	72	86,4	115,2	129,6	144	165,6
1	VT 100/4/152 C.348	mt	5	4,2	3,5	3	2,2					
2	VT 100/4/152 C.349		7	6	5	4,5	3,5	2,5				
3	VT 100/4/152 C.350		9	8,5	7	6	5	4	2			
4	VT 100/4/173 C.355		11	10	9	8	7	6	3,5	2		
5	VT 100/4/173 C.356		15	14	12,5	11,5	10	8,5	5,5	3,5	2	
6	VT 100/4/173 C.358		18	17	15,5	14,5	13	11,5	8,2	6,5	5	3

N°	Tipo Type	EX	Mandata Delivery	Passaggio Free Passage	kW			R.P.M. 1/min	A 3 Phase - 400V	Hz	
					P1	P2	HP				
1	VT 100/4/152 C.348	•	DN100 PN16	100 mm	2,2	1,7	2,3	1450	3,9	50	
2	VT 100/4/152 C.349	•			3,0	2,2	3				5,2
3	VT 100/4/152 C.350	•			3,8	3	4				7,2
4	VT 100/4/173 C.355	•		90 mm	5,3	4	5,5				9,2
5	VT 100/4/173 C.356	•			6,9	6	8				12,4
6	VT 100/4/173 C.358	•			9,0	7,5	10				15,7

• Pompa antideflagrante disponibile con certificazione
Available explosion proof pump



EPT 17 ATEX 2702 X



Ex db IIB T4 Gb
Ex h IIB T4 Gb
0° ≤ Ta ≤ 40°

V4

∇ Sommergenza minima
Minimum submersion

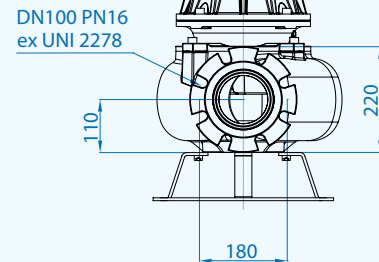
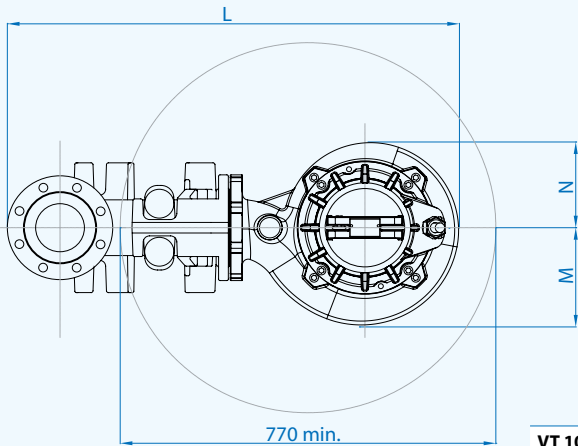
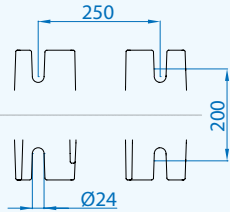
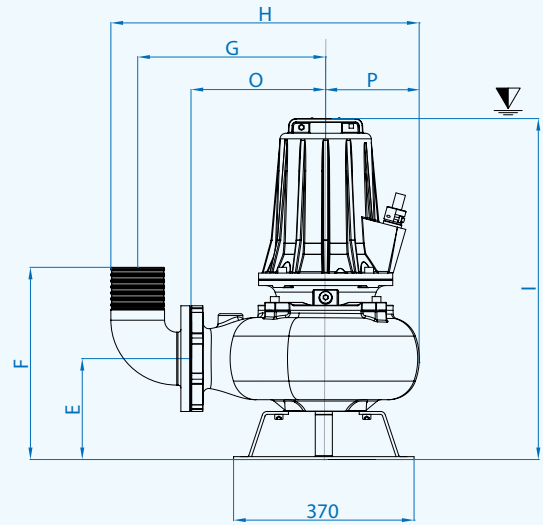
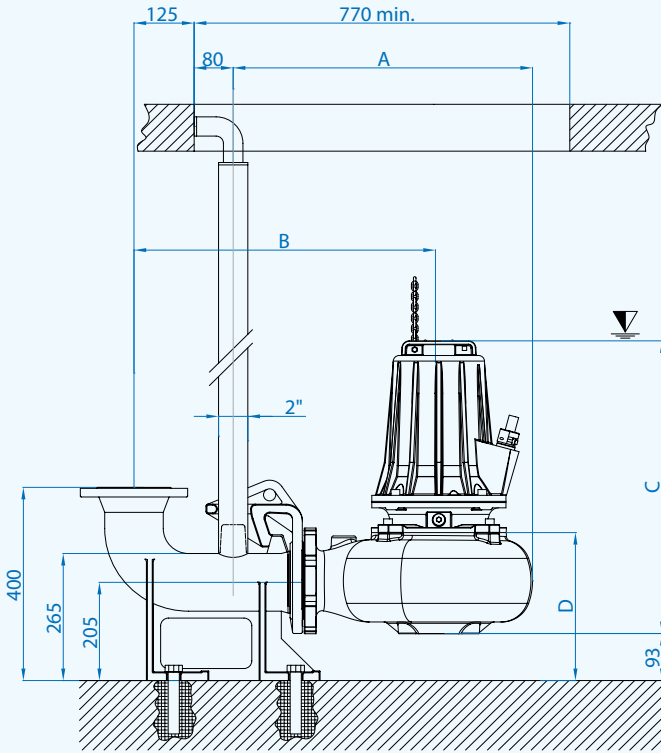

Quote in mm
Dimensions in mm

	A	B	C	D	E	F	G	H	I	L	M	N	O	P
VT 100/4/152 C.348-349-350	546	576	541	286	210	401	340	569	641	864	170	148	230	157
VT 100/4/173 C.355-356-358	614	618	609	308	212	400	385	632	710	910	207	168	278	192

Cavi / Cables

Pompe Pumps	Versione Version	Fasi Phases	Cavo Cable	Sezione cavo mm ² Cable cross section mm ²	mt
100/4/152	Standard	3 ~ 400V	H07RN8F	4x1,5+3x0,50 Ø15*	10
	ATEX	D.O.L.	NSSHÖU-J	4x1,5+3x0,50 Ø17*	10
100/4/173	Standard	3 ~ 400V	H07RN8F	7x1,5+3x0,50 Ø17*	10
	ATEX	Y-Δ	NSSHÖU-J	7x1,5+3x0,50 Ø17*	10

* Terminali liberi - Free terminals

Dimensioni imballo / Packaging dimension

Tipo - Type	X mm	Y mm	Z mm	Kg
VT 100/4/152 C.348				69
VT 100/4/152 C.349	355	580	420	69
VT 100/4/152 C.350				72
VT 100/4/173 C.355				100,5
VT 100/4/173 C.356	400	620	470	107
VT 100/4/173 C.358				110

Accessori - Optional



Piede di accoppiamento
Tipo: DUTY 100 e B6
Automatic coupling foot
Type: DUTY 100 and B6



Curva flangiata con portagomma N3
Base di sostegno P6
Flanged hose connection N3
Foot support P6



Manico inox
Stainless steel handle