

# Encapsulated Submersible Motors, 6" and 8"

# GB

## Assembly and operating instructions



Franklin Electric Europa GmbH  
Rudolf-Diesel-Straße 20  
D-54616 Wittlich, Germany  
Tel.: +49 (0) 65 71 / 105 - 0  
Fax: +49 (0) 65 71 / 105 - 520

E-Mail: [service-de@franklinwater.eu](mailto:service-de@franklinwater.eu)  
Internet: [www.franklinwater.eu](http://www.franklinwater.eu)

Doc.-Nb.: 308 018 418  
Version: Rev.17; October 2018

|           |   |            |
|-----------|---|------------|
| <b>1</b>  | <b>With this document</b> .....                         | <b>2</b>   |
| 1.1       | Warning notices and warning symbols .....               | 2          |
| 1.2       | Instructions and highlights .....                       | 2          |
| <b>2</b>  | <b>Safety</b> .....                                     | <b>3</b>   |
| 2.1       | Intended use .....                                      | 3          |
| 2.2       | Target group .....                                      | 3          |
| 2.3       | General safety instructions .....                       | 3          |
| <b>3</b>  | <b>Storage, transport, disposal</b> .....               | <b>4</b>   |
| <b>4</b>  | <b>Technical specifications</b> .....                   | <b>4/5</b> |
| <b>5</b>  | <b>Putting the motor into use</b> .....                 | <b>6</b>   |
| 5.1       | Checking the motor prior to installing it .....         | 6/7        |
| 5.2       | Motor and pump assembly .....                           | 7          |
| 5.3       | Motor cable .....                                       | 7/8        |
| 5.4       | Measuring the insulation resistance .....               | 8/9        |
| 5.5       | Making the electrical motor connection .....            | 9/10       |
| <b>6</b>  | <b>Motor operation</b> .....                            | <b>11</b>  |
| 6.1       | Making sure that the motor is cooled sufficiently ..... | 11/11      |
| 6.2       | Providing a check valve and a level sensor .....        | 11         |
| 6.3       | Switching on the motor .....                            | 11         |
| 6.4       | Operating a motor with a frequency converter .....      | 11         |
| 6.5       | Operating a motor with a soft starter .....             | 12         |
| <b>7</b>  | <b>Maintenance and service</b> .....                    | <b>12</b>  |
| <b>8</b>  | <b>Troubleshooting</b> .....                            | <b>12</b>  |
| <b>9</b>  | <b>Service</b> .....                                    | <b>12</b>  |
| <b>10</b> | <b>Appendix</b> .....                                   | <b>12</b>  |

© Copyright by Franklin Electric Europa GmbH 2005

All rights in these instructions are reserved – specifically the copying, distribution and translation rights. No part of these instructions shall be reproduced, or processed, copied or distributed using electronic systems or otherwise without the prior permission in writing of Franklin Electric Europa GmbH.

Changes due to technical developments reserved.

## 1 With this document

These assembly and operating instructions form an integral part of the submersible motor and describe its safe, intended use in all operating phases.

### Storage and handing over

- ⇒ Keep the assembly and operating instructions in the immediate vicinity of the motor.
- ⇒ Hand the assembly and operating instructions over to every subsequent user of the motor.

### Application

These assembly and operating instructions only apply to the motors described here.

### 1.1 Warning notices and warning symbols

Warning notices point out special dangers and indicate the measures that can be taken to avoid the danger. Warning notices come in three levels:

| Warning word   | Meaning   |
|----------------|---|
| <b>DANGER</b>  | Immediate danger to life and health                 |
| <b>WARNING</b> | Possible danger to life and health                  |
| <b>CAUTION</b> | Possible danger of slight injury or material damage |

Warning notices are built up as follows:



Warning word

---

*Type and source of danger as well as the possible consequences of measures not being observed!*

- ⊙ *Forbidden actions.*
  - ⇒ *Measures to avoid the danger.*
- 

### 1.2 Instructions and highlights

In these assembly and operating instructions, we use the following symbols and, for improved legibility and uniform identification, highlights:

- Insulation measuring unit (this indicates a listing)
- ☑ Instructions ... observed (this indicates a condition)
- ⇒ Switch off the motor. (this indicates an instruction to take action)
- Motor has stopped. (this indicates the result of the action)
- Immediately switch off** the motor... (you can see a highlight in bold here)



#### Note

*Specifically, important information is given here. You should observe this information to ensure correct and safe operation of the motor.*

## 2 Safety

This section describes the safety rules which you have to observe for the safe use of submersible motors. Possible sources of danger and the relevant safety measures are listed here.

### 2.1 Intended use

Franklin Electric submersible motors are only intended for integration with a machine in order to drive the relevant machine under water. They must only be put into use if the machine fulfils the provisions of the applicable directives and statutory provisions.

Installation location: Vertical (Mandatory mounting position: vertical, shaft up. Only one diameter step allowed, i.e. 6" motor on 8" pump). Horizontal (only allowed if the pump size is identical to the motor size, e.g. 6" motor with 6" pump). The pump has to sufficient "Down Thrust" transmit to the motor.

The submersible motors must only be used in clean, highly fluid media, such as drinking or process water.

The following media are not allowed: air, highly flammable, explosive media and wastewater.

#### Loss of guarantee and exclusion of liability

Franklin Electric shall not be liable for the damage resulting from any further, non-intended use. The risk of such use rests solely with the user.

### 2.2 Target group

The electrical system must only be installed by professional staff (qualified electrical engineers or electrical machine technicians).

### 2.3 General safety instructions

The following safety measures must be observed prior to putting the motor into use:

- Do not carry out any other work on the motor than described in these instructions.
- Only use the motor under water (the motor and the short motor cable must be fully submersed).
- Do not implement any changes or conversions to the motor or its electrical connections.
- Never open the motor.
- Never use the motor in combination with damaged pump units or parts.
- Only work on the motor when it is switched off. No work or checks require the motor to be running.
- Switch off the power supply to the motor before carrying out any work on it.
- Make sure that nobody can switch on the voltage unexpectedly while work is being carried out on the motor.
- Never work on electrical systems during a thunderstorm.
- Make sure immediately after ending the work that all protective and safety devices have been fitted again and are operational.
- Before switching on the motor, make sure that all electrical connections and safety devices have been checked and that all fuses and safeties have been set correctly.
- Make sure that no danger zones are freely accessible (e.g. rotating parts, suction locations, pressure output locations, electrical connections).
- Observe the pump manufacturer's commissioning instructions.
- If motors or pump units have been used in contaminated media they must be marked as such before handing them over to a third party (e.g. when submitting them for repair). Pay attention to possible residues in "Dead spaces" (diaphragm cover).
- Repairs must only be carried out by authorized professional workshops. Use only original Franklin Electric spare parts.

### 3 Storage, transport, disposal

- Storage**
- ⇒ Store the motor in its original packaging until the time of installing it.
  - ⇒ If the motor is stored standing up, make sure that it cannot topple over (shaft always pointing up!).
  - ⇒ Do not store the motor in direct sunlight or within the reach of other heat sources.
  - ⇒ Observe the storage temperature (-15 - +60 °C, see Technical specifications).

**Transport**



**DANGER**

---

***Falling loads may cause lethal injuries or may crush parts of the body!***

- ⊙ Nobody is allowed to be located under suspended loads.
  - ⇒ Only use approved hoisting gear.
  - ⇒ Select the hoisting gear on the basis of the total weight to be transported.
- 

**Unpacking**



**DANGER**

- ⇒ After unpacking the motor check it for possible damage, e.g. damage to the diaphragm cover, housing, endbell, connection and motor cable.
  - ⇒ Immediately inform the supplier of any damage found.
- 

***Danger to life due to electrocution if the motor cable is damaged!***

- ⊙ Do **not** install the motor and do **not** put it into operation.
- 

**Disposal** In order to avoid environmental damage:

- Avoid contamination by lubricants, detergents etc.
- Dispose of the motor and the packaging material in a proper, environmentally sound manner.
- Observe local regulations.

### 4 Technical specifications

| Description                                   | Value   |
|---|---|
| Performance/model number                      | 6": 4 - 45 kW (HighTemp90 up to 30 kW) models 236 ... (276 ...)<br>8": 30 - 150 kW (HighTemp75 up to 110 kW) models 239 ... (279 ...)                       |
| Voltage range                                 | 220 V ... 690 V, 3~ 50/60 Hz  |
| Frequency tolerance                           | ± 2%  |
| Voltage tolerance<br>(on the motor terminals) | 50 Hz: -10 / +6 % of U <sub>N</sub> , i.e. at a nominal voltage of 380-415 V:<br>380V -10 % = 342V / 415V + 6 % = 440 V<br>60 Hz: +/- 10% of U <sub>N</sub> |
| Speed   | approx. 2900 rpm at 50 Hz & 3450 rpm at 60 Hz   |
| Start alternatives                            | Direct starting, wye-delta-starting   |
| Switching frequency                           | 6" - Max. 20 switching actions per hour with a minimum off time of 90 s<br>8" - Max. 10 switching actions per hour with a minimum off time of 90 s          |
| Protection                                    | IP 68 according to IEC 60529  |
| Insulation class                              | F (155°C)   |



## 5 Putting the motor into use

### 5.1 Checking the motor prior to installing it

If a leak is visible or if the motor is more than one year old (e.g. in the event of re-use or after long storage):

⇒ Check the fluid level in the motor prior to installing it.

**Tools** You need the following tools for assembly and inspection work:

- Insulation measuring unit: 500 VDC testing
  - Filling Kit 308 726 103
- ⇒ Determine the age of the motor by checking the type plate (see Figure 5-1).

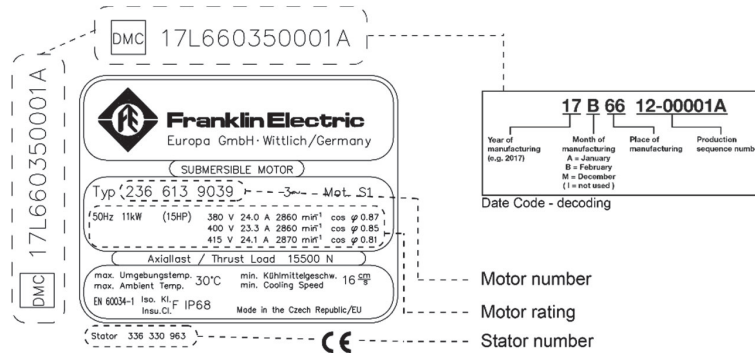

Figure 5-1: Type plate with date of manufacture

#### 5.1.1 Checking the motor fluid



**Motor damage due to being insufficiently filled!**

- ⇒ Fill the motor with sufficient motor fluid
- ⇒ Wear safety goggles and gloves when filling and draining the motor.

⇒ Top up using original motor fluid from Franklin Electric (5 litres concentrate Id. no. 308 353 941)  
**Never use distilled water!**

#### Filling volumes

- 6": max. 1.5 liter
- 8": max. 3.5 liter

#### Venting the motor

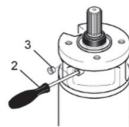

Figure 5-2: Venting the motor

⇒ Place the motor horizontally so that the filling valve is located at the highest position.

⇒ Remove the plug (3) from the filling valve.

Carefully push the test pin (2) into the filling valve until air and some fluid escape from it.

#### Checking the motor

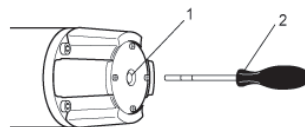

Figure 5-3: Checking the motor fluid

⇒ Feed the test pin (2) through the opening (1) in the diaphragm housing until you can feel resistance.

⇒ Measure the actual diaphragm distance to the side of the opening in the diaphragm cover.

- If the measured result is not identical to the target value:
- 59 mm ± 2 mm (6"- motor-Cast iron/304SS / 4-30kW)
  - 25 mm ± 2 mm (6"- motor-304SS/316SS / 4-30kW)
  - 47 mm ± 2 mm (6"- motor-304SS/316SS - 37/45kW)
  - 47 mm ± 2 mm (6"- HighTemp90)
  - 44 mm ± 2 mm (6"- 45kN Version)
  - 37 mm ± 2 mm (8"- motors all)

### Topping up the motor

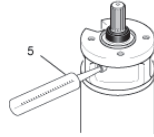

Figure 5-4: Topping up the motor fluid

- ⇒ Top up or drain motor fluid.
- ⇒ Apply the filling syringe (5) to the filling valve.
- ⇒ Top up the motor filling fluid until the value of the diaphragm position is lower than the target value.

- Adjusting the motor**
- ⇒ Adjust the diaphragm position by draining (see Venting) or topping up motor fluid until the target value is reached.
  - ⇒ Fit the plug (3) again.

## 5.2 Motor and pump assembly



**Note**

*This assembly and operating instructions only describe action steps related to the motor. You should also observe the pump unit manufacturer's instructions in all events.*

- Preparation**
- Short motor cable fitted (see 5.3.1)
  - Shaft protector removed
  - Motor shaft rotated manually before assembly – runs freely after overcoming static friction
  - Surfaces of parts to be connected are free from dust and dirt
  - Coupling attached to the pump shaft, slides on the motor shaft

**Assembly**

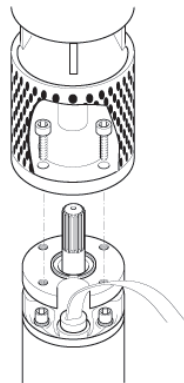

Figure 5-5: Pump assembly

- ⇒ Apply water-resistant, FDA approved, approved-free grease (e.g. Mobil FM 102, Texaco Cygnus) to the inner part of the coupling to the pump unit.
- ⇒ Make sure that the splined section is encased by an O-ring when the motor and the pump unit are assembled together.
- ⇒ Align the pump unit and motor shaft to each other, connect the pump unit and the motor.
- ⇒ Screw the motor to the pump unit, tighten the fixing screws crosswise as instructed.
  - 6": ½"-20 UNF-2B
  - 8": Bore Ø 17.5 mm
- ⇒ Protect the coupling location against contact.

## 5.3 Motor cable



**CAUTION**

**Motor damage due to damaged motor cable!**

- ⇒ Make sure that the motor cable is not in contact with any sharp edges.
- ⇒ Protect the cable against damage using the cable guard.

### 5.3.1 Connecting the short motor cable



**Note**

⇒ Always a **new** cable must be used

**Tools and Torques**

You need to use the following tools and torques for assembly and inspection work:

- 6" Motors Cast iron/304SS (all Ratings) 60 N/m ±6 N/m; Wrench 1 3/16" (30,2 mm)
- 6" Motors 304SS/316SS (all Ratings) 60 N/m ±6 N/m; Wrench 32 mm
- 8" Motors (30 – 93kW) 74 N/m ±7 N/m; Wrench 1 3/16" (30,2 mm) oder 1 5/8" (42 mm)
- 8" Motors (110 – 150kW) 9,0 N/m ±1 N/m, Allen Key 3/16" (4,7 mm)

**Preparation**

- Remove the sealing plug (1)
- Clean and dry the surfaces of the plug (2) and the socket (3)

**Assembly**

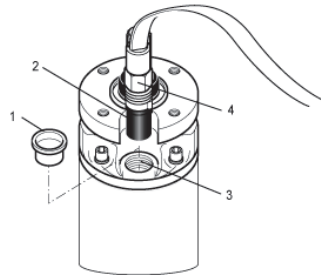

- ⇒ Pull back the jam nut (4) until the plug (2) is free
- ⇒ Apply FDA approved grease or Vaseline to the rubber casing surfaces
- ⇒ Apply acid-free grease to the thread of the union nut
- ⇒ Insert the plug (4) in the socket (3)

Figure 5-5: Connection of the short motor cable

### 5.3.2 Extending the motor cable

- The unit manufacturer's instructions regarding the cable connection have been observed
- Only extension cable and insulating material used which are suitable for the specific use (specifically drinking water) and which are approved for the temperatures occurring in the relevant medium
- Cable cross-sections: The tables in the appendix only serve as recommended suggestions. The fitter is responsible for the correct selection and dimensioning of the cable
- ⇒ Lay the cable along the pump.
- ⇒ Connect the ground conductor correctly (motors or integrated ground conductors are prepared for external grounding).
- ⇒ Protect the cable connection location against water penetration (shrink hoses, compounds or ready cable sets).
- ⇒ Make sure that the short motor cable is always fully surrounded by transport medium for proper cooling during operation.

## 5.4 Measuring the insulation resistance

This measurement is to be carried out using an insulation measuring unit (500 VDC) before and while submersing the fully assembled unit at the place of use.

- ⇒ Before submersing the unit, connect a measuring cable to the ground conductor.
- ⇒ Make sure that the contact points are clean.
- ⇒ Connect the other measuring cable to every core of the connected motor cable in succession. The insulation resistance is shown on the insulation measuring unit.



**For your information** Minimum insulation resistance (500 VDC; 1 min.; 20°C) **with extension cable:**

- for a new motor > 4 MΩ
- for a used motor > 1 MΩ

Minimum insulation resistance (500 VDC; 1 min.; 20°C) **without extension cable:**

- for a new motor > 400 MΩ
- for a used motor > 20 MΩ

## 5.5 Making the electrical motor connection



### *Danger to life due to electrocution!*

⇒ Prior to making the electrical motor connection make sure that there is no more voltage on the entire plant and that nobody can accidentally switch on the voltage again while the work is being carried out.

Observe the instructions on the motor type plate and dimension the electrical system accordingly. The connection examples in this chapter concern the actual motor and do not serve as recommendation for the upstream control elements.

- All action steps of the previous chapter have been carried out properly
- Additional safety instructions for submersible synchronous motors

### Energy supply by generator



#### Note

We urgently recommend that you discuss the plant dimensions with the generator manufacturer.

The voltage tolerance  $-10\%$  to  $+6\%$  -50Hz and  $\pm 10\%$  - 60Hz motors (on the motor terminals) and the deviation of a motor current from the mean value of all three currents must not be more than 5 %.

- Generator selected on the basis of the motor start behaviour, i.e. starting current with a mean  $\cos \phi$  of 0.5
  - Sufficient continuous generator power available
  - Voltage at start at least 55 % of the nominal voltage
- ⇒ You must follow the following switch-on sequences unconditionally:  
 first switch on the generator and then the motor.  
 first switch off the motor and then the generator.

### Fusing and motor protection

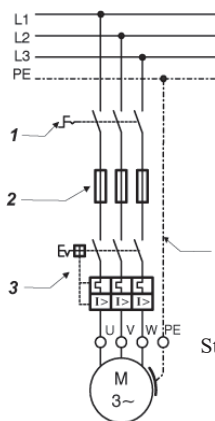

Standard:  
 U = black  
 V = grey (blue)  
 W = brown

6" HiTemp90  
 U= black  
 V= white  
 W= red

- ⇒ Provide an external mains switch (1) enabling the voltage to be removed from the system.
- ⇒ Provide fuses (2) for every single phase on site.
- ⇒ Provide a motor starting and protection switch (3) (see connection alternatives)
- ⇒ Provide an emergency stop system, if required for your specific application.
- ⇒ Ground the motor (4) (exterior grounding possible with all motors)

Figure 5-10: Fusing and motor protection

**Surge voltage protection**

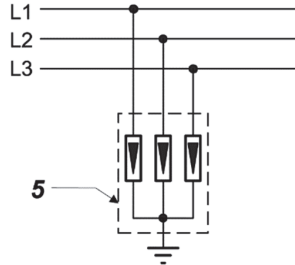

⇒ Integrate an overload protector in accordance with IEC 60099 in the power supply (lightning safety (5)).

Figure 5-12: Surge voltage protection

**Connection alternatives**

The motors can be used for clockwise and anti-clockwise rotation. The connection example shows the usual circuit with a right-hand field and an anti-clockwise direction of rotation:

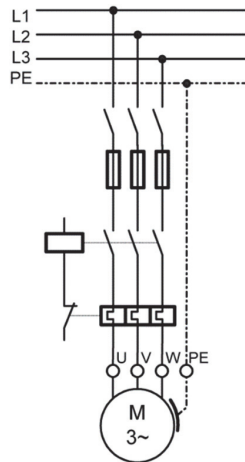

Figure 5-13: Direct starting

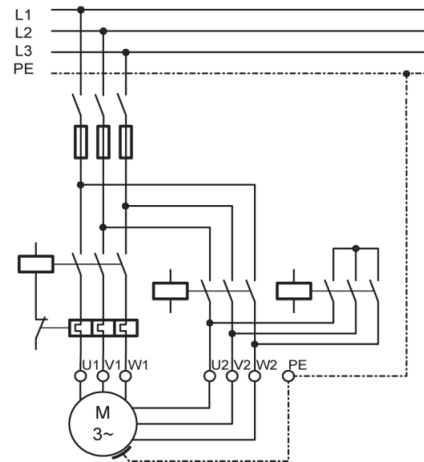

Figure 5-14: Wye-delta-starting

**Motor safety switch**

A motor safety switch (overload relay) is absolutely necessary!

Only use thermal trips of tripping categories 10A or 10, with

- ⇒ tripping time < 10 s at 500 %  $I_N$  (nominal current),
- ⇒ phase sensitivity,
- ⇒ temperature compensation from 20 to 40 °C.
- ⇒ Set the motor protection unit to the value of the operating current measured without exceeding the rated motor current  $I_N$  (as indicated on the type plate).

## 6 Motor operation

### 6.1 Making sure that the motor is cooled sufficiently



Caution

#### *Damage to the motor and the motor cable due to overheating*

- ⇒ Make sure that the coolant flow speed along the motor is sufficient.
- ⇒ Make sure that the short motor cable is always fully surrounded by transport medium for proper cooling.

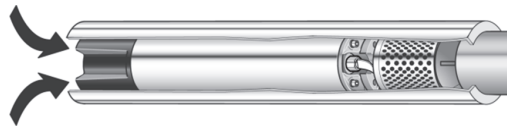

Figure 6-1: Cooling tube

If the required minimum coolant flow speed cannot be reached (e.g. if the inlet opening of the well is located above the motor or if using large-diameter wells):

- ⇒ Fit a cooling tube (see figure 6-1).
- ⇒ Make sure that the cooling tube encases the entire motor and the pump water inlet opening.  
The motor is force-cooled.

### 6.2 Providing a check valve and a level sensor

- ⇒ Provide one spring-loaded check valve in the production tube in case no such check valve has been fitted in the pump.
- ⇒ Ensure that the first check valve is no further than 7 m (metres) away from the pump.
- ⇒ Install a level sensor for wells with a highly varying water inflow.

### 6.3 Switching on the motor

- All action steps of the previous chapter have been carried out properly
- ⇒ Switch on the motor using the mains switch in the control cabinet.
- ⇒ Measure the following values after switching on:
  - Motor operating current in every phase
  - Mains voltage when motor is running
  - Level of the medium to be transported
- ⇒ **Immediately switch off the motor if:**
  - the nominal current as specified on the type plate is exceeded,
  - voltage tolerances of more than -10 % / +6 % to 50Hz and +/- 10% to 60Hz, relative to the nominal voltage are measured on the motor,
  - there is a risk of the motor running dry,
  - a motor current deviates from the mean value of all three currents by more than 5 %.

### 6.4 Operating a motor with a frequency converter



#### Note

*When operating a motor with a frequency converter, the relevant operating manual must be observed!*

- ⇒ Make sure that the motor current in all operating levels of the regulating range does not exceed the nominal motor current indicated on the type plate.
- ⇒ Adjust the frequency converter so that the limit values for the nominal motor frequency of min. 30 Hz and max. the value of the nominal motor frequency are observed.
- ⇒ Limit any voltage peaks on the motor when using a frequency converter to the following values:  
max. voltage rises 500 V/μs, max. voltage peak 1000V.

- ⇒ Make sure that the running up time from 0 to 1800 rpm and the deceleration time from 1800 to 0 rpm is maximum one second.
- ⇒ Dimension the cable such that power loss due to additional filters is taken into consideration.
- ⇒ Make sure that the required coolant flow speed along the motor is also observed with frequency converter operation.

## 6.5 Operating a motor with a soft starter



**Note**

*When operating a motor with a soft starter, the relevant operating manual must be observed!*

- ⇒ Set the starting voltage of the soft starter to 55 % of the nominal voltage and set the running up and delay times to max. three seconds.
- ⇒ Bridge the soft starter after running up, using a contactor.

## 7 Maintenance and service

The motor is maintenance-free; no maintenance or service activities are necessary.

## 8 Troubleshooting

| Fault   | Remedy   |
|---|--|
| Unusual noises, problems with the true running of the pump or the pump switching on and off too frequently. | ⇒ Try to find the cause of the fault on the pump unit.   |
| The pump repeatedly switches off  | <ul style="list-style-type: none"> <li>⇒ Have the insulation resistance checked by a professional (see chapter 5.4).</li> <li>⇒ If no cause can be found in the motor or the motor cable: Have the electrical system checked.</li> </ul> |

## 9 Service

- Repairs must only be carried out by authorised professional workshops (only use original Franklin Electric spare parts).
- Please note the additional safety instructions for submersible synchronous motors
- If you have any questions or problems, please contact your dealer or contact Franklin Electric via web: franklinwater.eu or mail to service-de@franklinwater.eu.

## 10 Appendix

| Page   | Explanation                              |
|--------|--|
| Page A | Outline drawings 6" / 8" Standard Motors |
| Page B | Outline drawings HiTemp 75/90 Motors     |
| Page C | Motor Test Report (MTR)                  |
| Page D | Cable cross-sections DOL and YD          |

### 6" Encapsulated

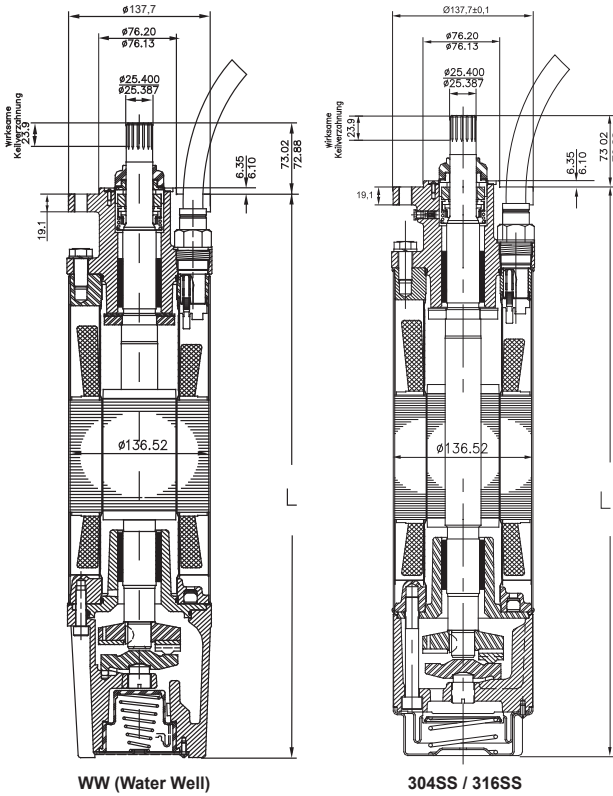
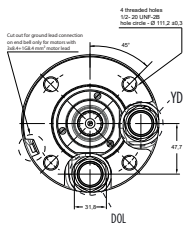

### 6" Encapsulated PM

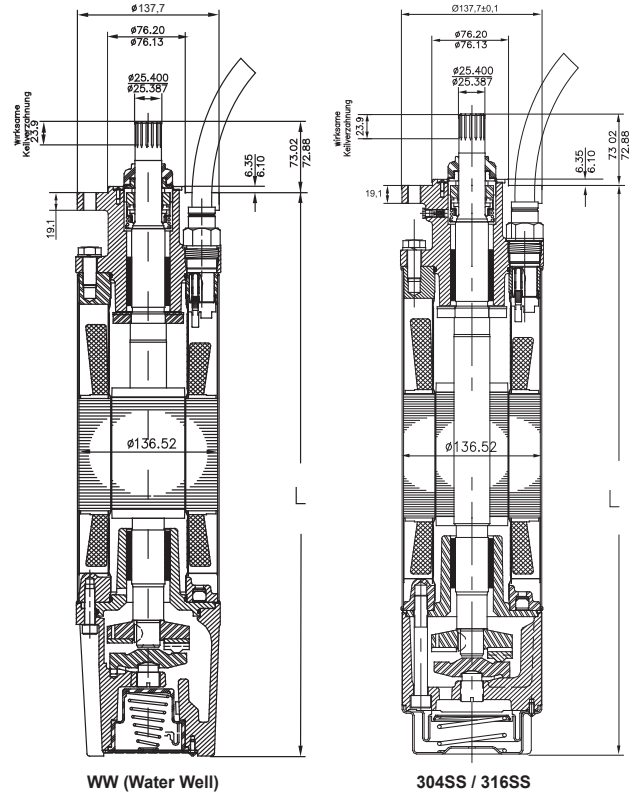
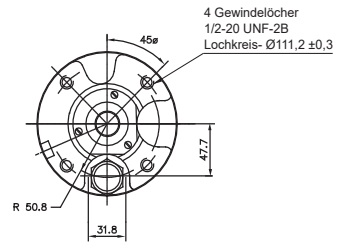

| P <sub>N</sub><br>[kW] | WW<br>L [mm] | 304SS*<br>L [mm] | 316SS**<br>L [mm] | Motor Package<br>Size [mm] | Shipping<br>Weight [kg]*** |      |
|------------------------|--------------|------------------|-------------------|----------------------------|----------------------------|------|
|                        |              |                  |                   |                            | DOL                        | YΔ   |
| 4                      | 581,2        | 570,7            | 570,7             | 155 x 340<br>x 800         | 41,3                       | 40,3 |
| 5,5                    | 614,4        | 604,0            | 604,0             |                            | 44,9                       | 43,9 |
| 7,5                    | 646,2        | 635,8            | 635,8             |                            | 49,0                       | 48,0 |
| 9,3                    | 678,7        | 668,3            | 668,3             | 155 x 340<br>x 1070        | 51,3                       | 50,3 |
| 11                     | 711,2        | 700,8            | 700,8             |                            | 54,7                       | 53,7 |
| 15                     | 776,2        | 765,8            | 765,8             |                            | 60,5                       | 59,5 |
| 18,5                   | 841,5        | 831,1            | 831,1             |                            | 67,1                       | 66,1 |
| 22                     | 906,5        | 896,1            | 896,1             |                            | 73,1                       | 72,1 |
| 30                     | 1036,6       | 1026,2           | 1026,2            | 155 x 340 x 1200           | 87,7                       | 87,7 |
| 37                     | -            | 1476,7           | 1476,7            | 223 x 267                  | 136                        |      |
| 45                     | -            | 1629,2           | 1629,2            | x 1823                     | 156                        |      |

| P <sub>N</sub><br>[kW] | WW<br>L [mm] | 304/316<br>L [mm] | Motor Package<br>Size [mm] | Shipping<br>Weight [kg] |
|------------------------|--------------|-------------------|----------------------------|-------------------------|
| 4 - 11                 | 634,5        | 625,2             | 155 x 340 x 800            | 45                      |
| 13 - 22                | 793,5        | 784,2             | 155 x 340<br>x 1070        | 61                      |
| 26 - 45                | 1020,5       | 1011,2            |                            | 84                      |

\* HighThrust Version + -60mm  
 \*\* HighThrust Version + -70mm  
 \*\*\* HighThrust Version + -4Kg

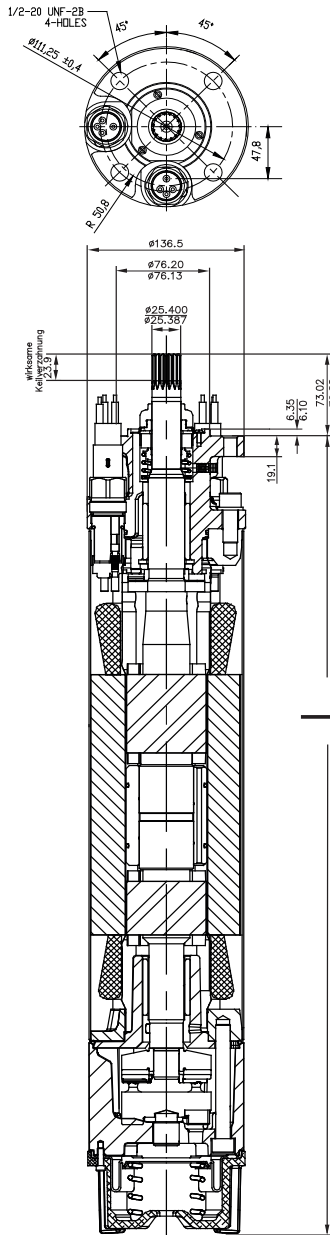
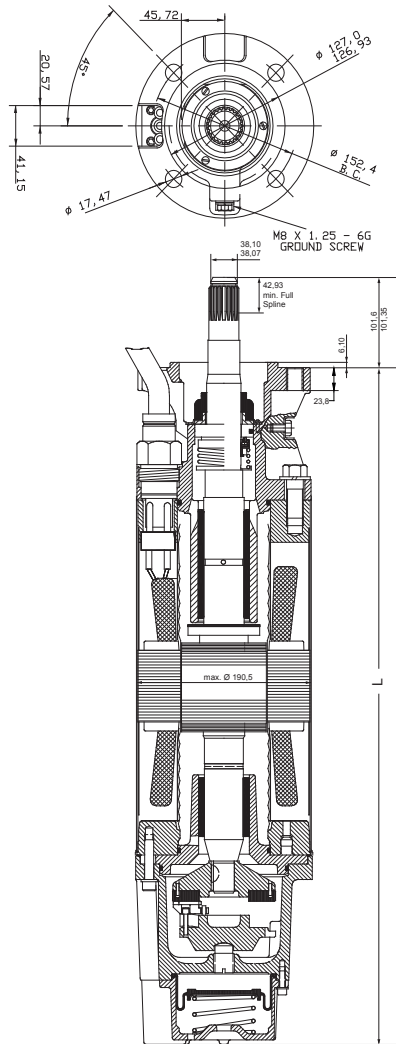
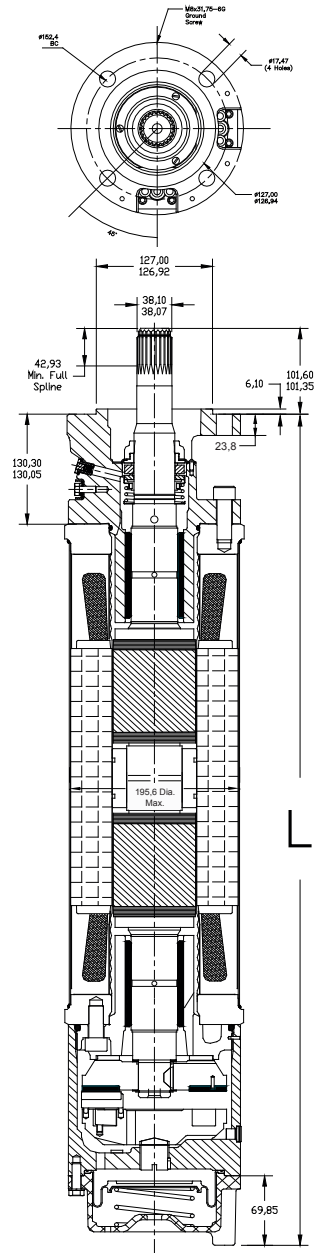
**6" Encapsulated  
HighTemp 90°C**

**8" Encapsulated**

**8" Encapsulated  
HighTemp 75°C**

| $P_N$<br>[kW] | L<br>[mm] | Motor Package<br>Size [mm] | Shipping<br>Weight [kg] | $P_N$<br>[kW] | L<br>[mm] | Motor Package<br>Size [mm] | Shipping<br>Weight [kg] | $P_N$<br>[kW] | L<br>[mm] | Motor Package<br>Size [mm] | Shipping<br>Weight [kg] |
|---------------|-----------|----------------------------|-------------------------|---------------|-----------|----------------------------|-------------------------|---------------|-----------|----------------------------|-------------------------|
| 3.7           | 670,5     | 190,5 x 273,5<br>x 876,3   | 55                      | 30            | 925       | 228 x 430<br>x 1308        | 145                     | 30            | 1138      | 432 x 245 x<br>1295        | 182                     |
| 5.5           | 735,5     |                            | 61                      | 37            | 1000      |                            | 157                     | 37            | 1265      |                            | 207                     |
| 7.5           | 800,6     |                            | 68                      | 45            | 1077      |                            | 172                     | 45            | 1455      |                            | 252                     |
| 11            | 866       |                            | 73                      | 55            | 1264      |                            | 227                     | 55            | 1747      |                            | 318                     |
| 15            | 931       |                            | 81                      | 75            | 1455      |                            | 265                     | 75            | 1976      |                            | 382                     |
| 18.5          | 1061      |                            | 94                      | 93            | 1748      |                            | 318                     | 93            | 2179      |                            | 421                     |
| 22            | 1429      | 222,2 x 273,5 x<br>1822,4  | 138                     | 110           | 1976      | 381                        | 110                     | 2408          | 473       |                            |                         |
| 30            | 1581,6    |                            | 152                     | 130           | 2179      | 420                        | 130                     | 2408          | 494       |                            |                         |



FEE - NO.: \_\_\_\_\_

VISIT DATE: \_\_\_\_\_

### Motor Test Report

Additional comments under "Remarks"

|   |                                      |                                       |   |
|---|--------------------------------------|---------------------------------------|---|
| <b>1. CUSTOMER / USER</b>                         |                                      |                                       |   |
| Company: _____                                    | Country: _____                       | Town: _____                           |   |
| Talked To: _____                                  | Tel.: _____                          | Assembler: _____                      |   |
| <b>2. MOTOR</b>                                   |                                      |                                       |   |
| Model-Nb.: _____                                  | Rating [kW]: _____                   | Voltage [V]: _____                    | Hz: _____   |
| Date Code: _____                                  | Sequenz-Nb.: _____                   | Stator- Nb.: _____                    | Material: _____   |
| Built in: _____                                   | Equipped for: _____                  | Worked with: _____                    |   |
| Worked for: <input type="checkbox"/> Month: _____ | <input type="checkbox"/> Days: _____ | <input type="checkbox"/> Hours: _____ | <input type="checkbox"/> Date failed: _____               |
| <b>3. INSTALLATION</b>                            |                                      |                                       |   |
| <input type="checkbox"/> Vertical                 | <input type="checkbox"/> Horizontal  | Pump Make: _____                      | Type: _____   |
| Well depth [m]: _____                             | Well diameter [cm]: _____            | Pump at [m]: _____                    | Water inlet at [m]: _____                                 |
| Cable lenght [m]: _____                           | Cable square[m]: _____               | Protection make: _____                | Type: _____   |
| Water: _____                                      | Temperature: _____                   | PH-Value: _____                       | Setting [A]: _____  |
| <b>4. EXTERNAL MEASUREMENTS</b>                   |                                      |                                       |   |
| Shaft high: _____                                 | Upper End Bell: _____                | Shaft Rotation: _____                 | Slinger: _____  |
| Stator Shell: _____                               | Lower End Bell: _____                | Deposits: _____                       | Valve: _____  |
| Splines: _____                                    | Diaphragm Pos.: _____                | Lead Insul.: _____                    | Connector: _____  |
| Nameplate: _____                                  | Leakage: _____                       | Lead Clamp: _____                     | Hi-Pot: _____   |
| Lead Sealing: _____                               | Plug Resin: _____                    |                                       |   |
| <b>5. ELECTRICAL MEASUREMENTS</b>                 |                                      |                                       |   |
| Phase 1 [Ω]: _____                                | Phase 2 [Ω]: _____                   | Phase 3 [Ω]: _____                    |   |
| Mainphase [Ω]: _____                              | Startphase [Ω]: _____                | Insulation Resist. [MΩ]: _____        |   |
| <b>6. TEARDOWN</b>                                |                                      |                                       |   |
| Prong: _____                                      | Windings: _____                      | Winding Splicing: _____               |   |
| Filling Liquid: _____                             | Diaphragm: _____                     | Segments: _____                       |   |
| Thrust Bearing: _____                             | Lower Radial Bearing: _____          | Upper Radial Bearing: _____           |   |
| Sleeve Lower Shaft End : _____                    | Sleeve Upper Shaft End : _____       | Up-Thrust Bearing: _____              |   |
| Shaft Seal : _____                                | Liner : _____                        | Rotor Core PM: _____                  |   |
| Stator Endring : _____                            | Cage Thrust Bearing : _____          | Pressure Test Line : _____            |   |
| Pressure Test Stator PU : _____                   |                                      |                                       |   |
| <b>7. CONTROL BOX</b>                             |                                      |                                       |   |
| Control Box Type: _____                           | Defective: _____                     |                                       |   |
| <b>8. REMARKS</b>                                 |                                      |                                       |   |
|   |                                      |                                       |   |
| Tech. Warranty : _____                            | Com. Warranty: _____                 | <input type="checkbox"/> Repair       | <input type="checkbox"/> Scrap Defect: _____ Cause: _____ |
| Signature: _____                                  | Date: _____                          | Entered into EDP: _____               | Date: _____   |

| maximum lengths in meters for 400V / 50Hz and 3% voltage drop at 50°C ambient temperature and 90°C at copper wire |      |  |     |     |     |     |     |     |     |     |      |      |      |     |     |     |     |     |     |
|---|------|--|-----|-----|-----|-----|-----|-----|-----|-----|------|------|------|-----|-----|-----|-----|-----|-----|
| Jacketed Drop Cable Length  |      |  |     |     |     |     |     |     |     |     |      |      |      |     |     |     |     |     |     |
| DOL - Delta start   |      |  |     |     |     |     |     |     |     |     |      |      |      |     |     |     |     |     |     |
| rating  |      | cable size mm <sup>2</sup> , copper wire - 90°C rated insulation |     |     |     |     |     |     |     |     |      |      |      |     |     |     |     |     |     |
| KW  | HP   | 2,5  | 4   | 6   | 8,4 | 10  | 16  | 25  | 35  | 50  | 70   | 95   | 120  | 150 | 185 | 240 | 300 | 400 | 500 |
| 4   | 5,5  | 95   | 155 | 230 | 325 | 385 | 605 | 915 |     |     |      |      |      |     |     |     |     |     |     |
| 5,5   | 7,5  | 70   | 110 | 170 | 235 | 280 | 440 | 670 | 915 |     |      |      |      |     |     |     |     |     |     |
| 7,5   | 10   | 50   | 80  | 126 | 175 | 205 | 325 | 500 | 685 | 935 |      |      |      |     |     |     |     |     |     |
| 9,3   | 12,5 | 40   | 65  | 100 | 145 | 170 | 270 | 410 | 565 | 770 | 1030 |      |      |     |     |     |     |     |     |
| 11  | 15   |  | 55  | 85  | 120 | 140 | 225 | 345 | 470 | 645 | 865  | 1110 |      |     |     |     |     |     |     |
| 13  | 17,5 |  | 50  | 75  | 105 | 125 | 195 | 300 | 410 | 560 | 750  | 965  |      |     |     |     |     |     |     |
| 15  | 20   |  | 40  | 65  | 90  | 105 | 170 | 265 | 360 | 495 | 665  | 855  | 1030 |     |     |     |     |     |     |
| 18,5  | 25   |  |     | 50  | 75  | 85  | 140 | 210 | 290 | 400 | 530  | 680  | 810  | 950 |     |     |     |     |     |
| 22  | 30   |  |     |     | 64  | 75  | 120 | 180 | 250 | 340 | 455  | 585  | 700  | 815 | 945 |     |     |     |     |
| 26  | 35   |  |     |     |     | 60  | 100 | 150 | 210 | 290 | 385  | 500  | 600  | 705 | 815 | 970 |     |     |     |
| 30  | 40   |  |     |     |     |     | 85  | 135 | 185 | 250 | 335  | 430  | 515  | 600 | 695 | 820 | 935 |     |     |
| 37  | 50   |  |     |     |     |     |     | 105 | 150 | 205 | 270  | 350  | 420  | 485 | 565 | 665 | 760 | 875 | 980 |
| 45  | 60   |  |     |     |     |     |     | 90  | 125 | 175 | 235  | 310  | 375  | 445 | 520 | 630 | 730 | 860 | 980 |
| 52  | 70   |  |     |     |     |     |     | 80  | 110 | 155 | 210  | 270  | 325  | 385 | 450 | 540 | 625 | 735 | 840 |
| 55  | 75   |  |     |     |     |     |     |     | 105 | 145 | 195  | 255  | 305  | 360 | 420 | 505 | 580 | 685 | 770 |
| 60  | 80   |  |     |     |     |     |     |     | 95  | 135 | 185  | 240  | 290  | 345 | 400 | 485 | 560 | 660 | 750 |
| 67  | 90   |  |     |     |     |     |     |     |     | 120 | 160  | 210  | 255  | 300 | 350 | 415 | 480 | 565 | 640 |
| 75  | 100  |  |     |     |     |     |     |     |     | 105 | 145  | 185  | 225  | 270 | 315 | 375 | 435 | 510 | 580 |
| 83  | 111  |  |     |     |     |     |     |     |     | 95  | 130  | 170  | 210  | 250 | 290 | 350 | 405 | 480 | 540 |
| 85  | 114  |  |     |     |     |     |     |     |     |     | 125  | 160  | 195  | 230 | 265 | 315 | 365 | 425 | 480 |
| 93  | 125  |  |     |     |     |     |     |     |     |     | 115  | 150  | 185  | 215 | 255 | 300 | 350 | 410 | 460 |
| 110   | 150  |  |     |     |     |     |     |     |     |     |      | 120  | 145  | 170 | 200 | 235 | 270 | 310 | 350 |
| 130   | 175  |  |     |     |     |     |     |     |     |     |      |      | 130  | 155 | 180 | 215 | 250 | 290 | 330 |
| 150   | 200  |  |     |     |     |     |     |     |     |     |      |      |      | 145 | 170 | 205 | 235 | 275 | 280 |
| 185   | 250  |  |     |     |     |     |     |     |     |     |      |      |      |     |     | 140 | 160 | 185 | 210 |
| 220   | 300  |  |     |     |     |     |     |     |     |     |      |      |      |     |     | 130 | 150 | 175 | 200 |
| 250   | 335  |  |     |     |     |     |     |     |     |     |      |      |      |     |     |     | 125 | 145 | 160 |
| 300   | 400  |  |     |     |     |     |     |     |     |     |      |      |      |     |     |     |     |     | 150 |
| 350   | 470  |  |     |     |     |     |     |     |     |     |      |      |      |     |     |     |     |     | 120 |
| 400   | 540  |  |     |     |     |     |     |     |     |     |      |      |      |     |     |     |     |     |     |

| Wye - Delta start |      |  |     |     |     |     |     |      |      |      |      |      |      |      |      |      |      |     |      |
|-------------------|------|--|-----|-----|-----|-----|-----|------|------|------|------|------|------|------|------|------|------|-----|------|
| rating            |      | cable size mm <sup>2</sup> , copper wire - 90°C rated insulation |     |     |     |     |     |      |      |      |      |      |      |      |      |      |      |     |      |
| KW                | HP   | 2,5  | 4   | 6   | 8,4 | 10  | 16  | 25   | 35   | 50   | 70   | 95   | 120  | 150  | 185  | 240  | 300  | 400 | 500  |
| 4                 | 5,5  | 145  | 230 | 350 | 485 | 575 | 900 |      |      |      |      |      |      |      |      |      |      |     |      |
| 5,5               | 7,5  | 106  | 170 | 250 | 350 | 420 | 660 | 1010 |      |      |      |      |      |      |      |      |      |     |      |
| 7,5               | 10   | 75   | 125 | 185 | 260 | 310 | 490 | 750  | 1025 |      |      |      |      |      |      |      |      |     |      |
| 9,3               | 12,5 | 60   | 100 | 155 | 215 | 255 | 405 | 620  | 845  | 1160 |      |      |      |      |      |      |      |     |      |
| 11                | 15   | 50   | 85  | 130 | 180 | 210 | 340 | 520  | 715  | 980  |      |      |      |      |      |      |      |     |      |
| 13                | 17,5 | 45   | 75  | 110 | 155 | 185 | 295 | 450  | 615  | 845  | 1125 |      |      |      |      |      |      |     |      |
| 15                | 20   | 40   | 65  | 95  | 135 | 160 | 260 | 395  | 540  | 740  | 995  |      |      |      |      |      |      |     |      |
| 18,5              | 25   | 30   | 50  | 80  | 110 | 130 | 210 | 320  | 435  | 600  | 800  | 1025 |      |      |      |      |      |     |      |
| 22                | 30   |  | 45  | 65  | 95  | 110 | 180 | 275  | 375  | 510  | 685  | 875  | 1050 |      |      |      |      |     |      |
| 26                | 35   |  | 35  | 55  | 80  | 95  | 150 | 230  | 315  | 435  | 580  | 750  | 900  | 1055 |      |      |      |     |      |
| 30                | 40   |  |     | 50  | 70  | 80  | 130 | 200  | 275  | 375  | 500  | 645  | 775  | 905  | 1045 |      |      |     |      |
| 37                | 50   |  |     |     | 55  | 65  | 105 | 160  | 220  | 305  | 410  | 525  | 625  | 730  | 845  | 1000 |      |     |      |
| 45                | 60   |  |     |     |     | 55  | 90  | 135  | 190  | 260  | 355  | 460  | 560  | 665  | 780  | 945  | 1095 |     |      |
| 52                | 70   |  |     |     |     |     | 50  | 80   | 120  | 165  | 230  | 310  | 405  | 490  | 580  | 680  | 815  | 940 |      |
| 55                | 75   |  |     |     |     |     |     | 75   | 115  | 155  | 220  | 295  | 380  | 460  | 545  | 635  | 760  | 875 | 1025 |
| 60                | 80   |  |     |     |     |     |     | 70   | 105  | 145  | 205  | 275  | 360  | 435  | 510  | 605  | 725  | 840 | 990  |
| 67                | 90   |  |     |     |     |     |     | 60   | 95   | 130  | 180  | 240  | 315  | 380  | 450  | 525  | 625  | 720 | 845  |
| 75                | 100  |  |     |     |     |     |     |      | 85   | 115  | 160  | 215  | 280  | 340  | 405  | 470  | 565  | 655 | 765  |
| 83                | 111  |  |     |     |     |     |     |      | 75   | 105  | 145  | 200  | 260  | 315  | 375  | 435  | 525  | 610 | 715  |
| 85                | 114  |  |     |     |     |     |     |      | 70   | 100  | 135  | 185  | 240  | 290  | 345  | 400  | 475  | 550 | 640  |
| 93                | 125  |  |     |     |     |     |     |      | 65   | 95   | 130  | 175  | 230  | 275  | 325  | 380  | 455  | 525 | 615  |
| 110               | 150  |  |     |     |     |     |     |      |      |      | 105  | 140  | 180  | 220  | 255  | 300  | 355  | 405 | 465  |
| 130               | 175  |  |     |     |     |     |     |      |      |      | 95   | 125  | 160  | 195  | 230  | 270  | 325  | 375 | 435  |
| 150               | 200  |  |     |     |     |     |     |      |      |      |      | 105  | 140  | 170  | 200  | 230  | 275  | 320 | 400  |
| 185               | 250  |  |     |     |     |     |     |      |      |      |      |      | 110  | 130  | 155  | 180  | 210  | 240 | 315  |
| 220               | 300  |  |     |     |     |     |     |      |      |      |      |      |      | 115  | 140  | 160  | 195  | 225 | 300  |
| 250               | 335  |  |     |     |     |     |     |      |      |      |      |      |      |      | 105  | 125  | 140  | 170 | 220  |
| 300               | 400  |  |     |     |     |     |     |      |      |      |      |      |      |      |      | 110  | 125  | 150 | 205  |
| 350               | 470  |  |     |     |     |     |     |      |      |      |      |      |      |      |      |      | 125  | 145 | 170  |
| 400               | 540  |  |     |     |     |     |     |      |      |      |      |      |      |      |      |      |      | 110 | 130  |

The voltage drop losses in the cable cross-section has a linear uniformity and can easily be converted from 3% to the respective voltage drop losses and the resulting length. An example: 45 KW motor DOL with cable cross section 25mm<sup>2</sup> has a max. cable length of 90 meters. What length can be achieved up to 5% voltage drop losses? Calculation: Length 90 m / 3 (%) x 5 (%) = 150 m



**EC Herstellererklärung**

Hersteller: Franklin Electric Europa GmbH  
Rudolf-Diesel-Strasse 20  
D-54516 Wittlich

Produkt: 6 und 8 Zoll Gekapselte Unterwassermotoren

Typbezeichnung: 226... 236... 239... 276... 279...

Die oben genannten Produkte sind mit den folgenden Europäischen Richtlinien konform:

2014/35/EU (Niederspannungsrichtlinie),  
und  
2014/30/EU (EMC Richtlinie)

Angewendete harmonisierte Standards: EN 60034-1

Angewendete nationale Standards: NEMA MG 1-2016: 18.70, 18.181

  
J. A. Weber  
Manager, Product Certification Engineering  
1 Februar 2018

**Déclaration de Conformité CE**

Fabricant: Franklin Electric Europa GmbH  
Rudolf-Diesel-Strasse 20  
D-54516 Wittlich

Produits: Moteur immergés 6" et 8" Encapsulés

Désignation: 226... 236... 239... 276... 279...

Les produits mentionnés ci-dessus sont conformes avec les Directives Européennes suivantes :

2014/35/EU (directive Basse Tension)  
et  
2014/30/EU (Directive EMC)

Standards harmonisés appliqués : EN 60034-1

Standard national appliqué : NEMA MG 1-2016: 18.70, 18.181

  
J. A. Weber  
Manager, Product Certification Engineering  
1 Février 2018

**EC Dichiarazione di Conformità**

Produttore: Franklin Electric Europa GmbH  
Rudolf-Diesel-Strasse 20  
D-54516 Wittlich/Germany

Prodotto: Motori sommersi incapsulati 6 e 8 pollici

Motori del tipo: 226... 236... 239... 276... 279...

I prodotti sopra descritti sono conformi alle seguenti Direttive Europee

2014/35/EU (Direttiva Basso Voltaggio)  
(e)  
2014/30/EU (Direttiva EMC)

in conformità' allo standard EN 60034-1

standard nazionali applicati: NEMA MG 1-2016: 18.70, 18.181

  
J. A. Weber  
Manager, Product Certification Engineering  
3 Febbraio 2018

**Declaración de Conformidad CE**

Fabricante: Franklin Electric Europa GmbH  
Rudolf-Diesel-Strasse 20  
D-54516 Wittlich/Germany

Producto: Motores Sumergibles encapsulados 6 y 8 pulgadas

Modelos: 226... 236... 239... 276... 279...

Los productos mencionados anteriormente están en conformidad con las siguientes Directivas Europeas:

2014/35/EU (Directiva Baja Tensión),  
y  
2014/30/EU (Directiva EMC)

Normas armonizadas aplicadas: EN 60034-1

Normas nacionales aplicadas: NEMA MG 1-2016: 18.70, 18.181

  
J. A. Weber  
Manager, Product Certification Engineering  
1 Febrero 2018

**Declaração de Conformidade EC**

Produtor: Franklin Electric Europa GmbH  
Rudolf-Diesel-Strasse 20  
D-54516 Wittlich/Alemanha

Produto: Motores Submersíveis de 6" e 8" do tipo encapsulado

Designação do tipo: 226... 236... 239... 276... 279...

Os produtos acima estão em conformidade com as seguintes diretivas europeias em vigor:

2014/35/EU (Directiva de baixa tensão),  
e  
2014/30/EU (Directiva EMC)

Padrões harmonizados aplicáveis: EN 60034-1

Padrões nacionais aplicáveis: NEMA MG 1-2016: 18.70, 18.181

  
J. A. Weber  
Manager, Product Certification Engineering  
1 Fevereiro 2018

**EC Declaration of Conformity**

Κατασκευαστής: Franklin Electric Europa GmbH  
Rudolf-Diesel-Strasse 20  
D-54516 Wittlich/Germany

Πρόϊόν: 6-inch and 8-inch Encapsulated Submersible motors

Όνομαστικό Τύπο: 226... 236... 239... 276... 279...

Τα παραπάνω προϊόντα είναι σύμφωνα με τις ακόλουθες ευρωπαϊκές οδηγίες:

2014/35/EU (Οδηγία για χαμηλή τάση)  
και  
2014/30/EU (EMC Οδηγία)

Εφαρμοσμένα ευρωπαϊκά πρότυπα: EN 60034-1

Εφαρμοσμένα εθνικά πρότυπα: NEMA MG 1-2016: 18.70, 18.181

  
J. A. Weber  
Manager, Product Certification Engineering  
1 Φεβρουάριος 2018

**بيان المطابقة لمتطلبات التوافقية الأوروبية**

المصنع: شركة فرانكلين إلكترونيكس أوروبا المحدودة  
(Rudolf-Diesel-Strasse 20  
D-54516 Wittlich ألمانيا)

المنتج: محركات غاطسية مغطاة 6 و 8 بوصة

أسماء النماذج: 226... 236... 239... 276... 279...

توافق المنتجات المذكورة أعلاه مع المتطلبات الأوروبية التالية:

EI/35/2014 (المتطلبات الخاصة بتحميل منخفض)  
و  
EI/30/2014 (المتطلبات الخاصة بالتوافق الكهرومغناطيسي)

EN 60034-1 المعيار المستندة بإمارة الامارات العربية

18.181-18.70-2016-1 MG NEMA المعيار الوطنية المستندة

  
J. A. Weber  
Manager, Product Certification Engineering  
1 فبراير 2018

**Üretici Beyanamesi**

Üretici: Franklin Electric Europa GmbH  
Rudolf-Diesel-Strasse 20  
D-54516 Wittlich

Ürünler: 6 ve 8 inçlik, Kapsül Tipi Dalgaçlı Motorlar

Modeller: 226... 236... 239... 276... 279...

Adı verilen ürünlerimiz, aşağıda belirtilen Avrupa Birliği yönetmelikleri ile uyumaktadır:

2014/35/EU: Aşağı Geniş Çapları Yönetmeliği  
2014/30/EU: EMC Elektromanyetik Uyumluluk Yönetmeliği

EN 60034-1: Döner Elektrik Makinaları Bölüm - 1 Beyan değerleri ve performans standartları

NEMA MG 1-2016: 18.70, 18.181: Ulusal Kullanım Standartları

  
J. A. Weber  
Manager, Product Certification Engineering  
Şubat 1, 2018

**Заявление о соответствии стандартам ЕС**

Изготовитель: Franklin Electric Europa GmbH  
Rudolf-Diesel-Strasse 20  
D-54516 Wittlich/Germany

Название изделия: 6-дюймовые и 8-дюймовые Гидравлические Погружные Электродвигатели

Тип изделия: 226... 236... 239... 276... 279...

Вышеуказанные погружные электродвигатели соответствуют требованиям следующие Европейские Директивы:

2014/35/EU Директива Европейского парламента и Совета от 12 декабря 2006 года по унификации правовых норм государств-членов ЕС относительно применения электрического оборудования в пределах стандартного диапазона значений напряжений (низковольтная директива)  
2014/30/EU Директива Европейского парламента и Совета по унификации законодательных директив стран-членов ЕС по электромагнитной совместимости (директива по EMC)

Применены согласованные стандарты: EN 60034-1

Применены национальные стандарты: NEMA MG 1-2016: 18.70, 18.181

  
J. A. Weber  
Manager, Product Certification Engineering  
1 февраля 2018 года



**Franklin Electric**



**Franklin Electric**

Franklin Electric Europa GmbH  
Rudolph-Diesel-Str. 20 - 54516 Wittlich  
DEUTSCHLAND  
Telefon: +49 (0) 6571 - 105-0  
Fax: +49 (0) 6571 - 105-510  
Email: [info@franklin-electric.de](mailto:info@franklin-electric.de)

Unternehmen unterliegt der Kontrolle und Koordination von Franklin Electric Co., Inc.  
Franklin Electric behält sich das Recht vor, die Spezifikation ohne vorherige Ankündigung zu ändern.

DOC.NB. 308-018-418 REV.19 07.2020