

**Ball check valve
flanged**

**PN10
PN16**

SEWAGE

WATER



Ball check valve 6616 DN40

Product description (standard execution):

- Silent and reliable operation
- Simple and compact design – high durability
- Thread connections according to EN 10226-1
- Face to face according to producer documentation JAFAR
- Body and bonnet made of ductile cast iron EN-GJS 400-15; EN 1563
- NBR/EPDM fully galvanized bowl (made of aluminum alloy or cast iron)
- Body-bonnet O-ring gasket: NBR/EPDM
- Epoxy coating minimum 250 microns according to EN ISO 14091
- Body bonnet steel screws 1.0038/Zn protected by wax or plastic caps
- Product 6616 designed for use in pumping/pressurized installations
- Product 6626 designed for use in gravity based installations
- Product according to EN 1074-1; EN 1074-3
- Product marking according to EN 19; EN 1074

Application:

Water and sewage networks and tanks. Transport of non aggressive liquids.
Working conditions:
temp. up +70°C
working pressure up to 1.6 MPa

Test control:

Water pressure test according to EN 1074-1; EN 1074-3; EN 12266-1
Seat: 0,5 to 1,1 xPN
Body: 1,5 x PN

Execution variant:

SS body bonnet screws
With drain plug (A)
With drain plug with vent mechanism (B)

Installation:

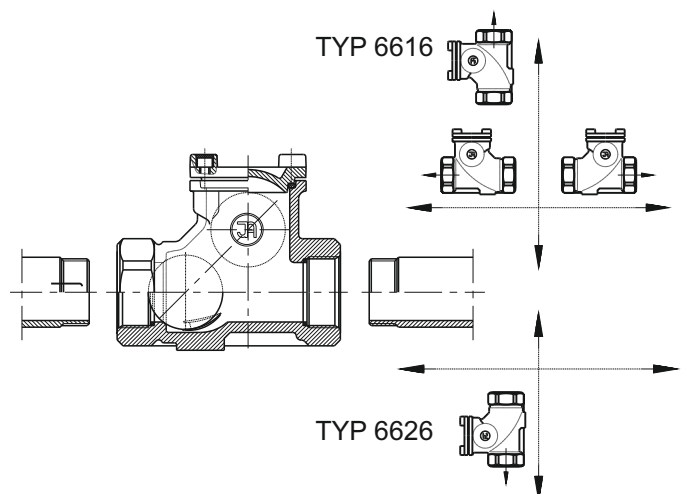

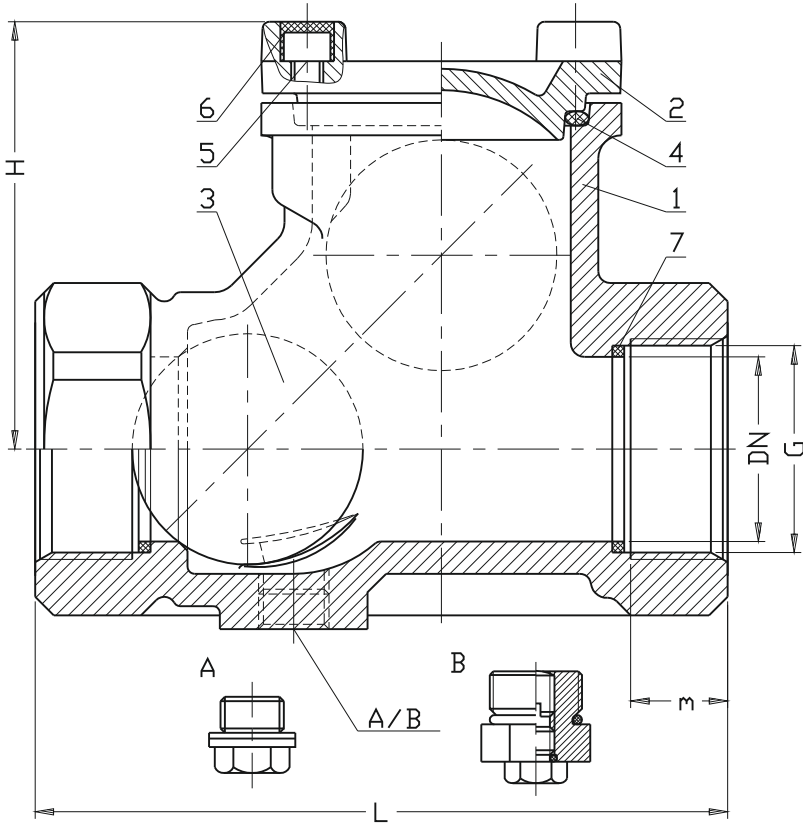

No.	Part	Standard execution
1	Body	Ductile cast iron EN-GJS-400-15; EN 1563
2	Bonnet	Ductile cast iron EN-GJS-400-15; EN 1563
3	Ball	Aluminium AISI EN 1706 Rubber NBR or EPDM EN-ISO 1629
4	Gasket	Rubber NBR or EPDM EN-ISO 1629
5	Screw	Steel Fe/Zn5 Stainless steel EN ISO 4762
6	Screw stopper	Wax
7	Gasket	Rubber NBR or EPDM EN-ISO 1629

DN	G	L	m	H	Weight	Weight
[mm]	[cal]		[mm]		6616 [kg]	6626 [kg]
25	1"	120	18	75	1,7	-
32	5/4"	140	18	75	2,2	-
40	6/4"	150	20	89	3,1	-
50	2"	220	35	113	5,0	4,2

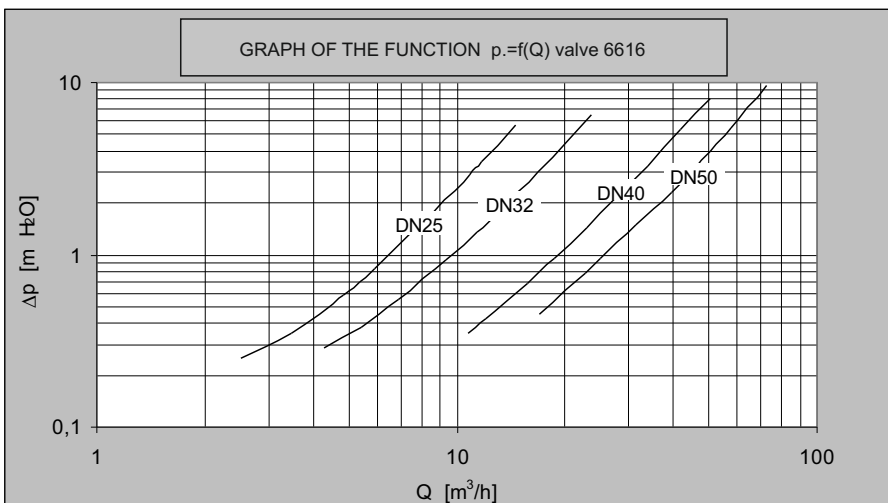

We reserve the rights to modify the production program and the given data without separate notices due to the permanent company development.