

4" SUPER STAINLESS MOTOR - 2WIRE DESIGN



FEATURES & BENEFITS

- 4" NEMA mounting design with metric studs
- Stainless steel splined shaft
- Stator shell in 316SS
- Factory filled with Franklin's non-toxic water soluble fill solution
- Max. storage temperature -15°C - + 50°C
- Liquid lubricated radial bearings and High capacity Kingsbury type thrust bearing for 100 % maintenance free operation
- Field replaceable lead using Franklin's exclusive Water Bloc technology with extended jam nut in Stainless steel
- High efficiency electrical design for low operation costs
- Drinking water approvals
- Suitable for use in water with increased salinity
- Internal Automatic reset overload
- Built-in surge arrestors

SPECIFICATION

- Ratings: 0.37 - 1.1 kW
- Frequency: 50 Hz
- Thrust load: 4 kN
- Nominal ambient temperature: 30 °C with 0.08 m/s cooling flow
- Voltage tolerance: -10 % / +6 % (50 Hz)
- Protection IP68, insulation class B
- Frequency of starts: 20 starts/ hour (with min. 3 minutes resting time)
- All motors with factory installed leads (1.50 m / 2.50 m)
- Special lead length up to 50 m,
- Installation orientation: Vertical / horizontal (shaft end heightened)
- Rotation counter clock wise facing shaft end (1 phase motors CW upon request)

Pollution Recovery version:

- Fluorelastomere (Viton®) rubber parts
- Special Polyuretane (PUR) lead assemblies
- 304SS (316SS Stator) graded Stainless Steel as Standard



OPTIONS

- Built in lightning arrestors
- Special lead lengths



ISO 9001

All motors are manufactured in ISO 9001 certified plants and 100% tested



Hydrodynamic liquid lubricated radial bearings

100 % maintenance free operation

StatorSHIELD™ - Franklin encapsulation system

Franklin Electric encapsulated motors are equipped with hermetically-sealed windings. The Anti track stator resin mechanically supports the winding and provides fast heat dissipation.

Kingsbury type thrust bearing

High capacity 4 kN Kingsbury type thrust bearing for 100 % maintenance free operation

Pressure-equalizing diaphragm



2-WIRE MOTOR DESIGN FUNCTION DESCRIPTION

BIAC Switch Operation/2-Wire Motor Solid State Controls

Power-On: When power is applied to the motor the bi-metal switch contacts are closed so that the TRIAC is conducting. This allows current to pass to the start winding, thus starting the motor.

The BIAC switch responds to voltage from a sensor coil located inside the motor. This sensor coil voltage is proportional to motor speed (RPM).

As speed increases, the increased voltage in the sensor coil generates heat in the bi-metal, causing it to open the start winding circuit. This cuts the starting winding current and the motor continues to run on the main winding only.

Power-off: Approximately 5 seconds after power is cut from the motor, the bi-metal strip cools sufficiently to return into its NC position, and the motor is ready for the next start cycle. If during operation, the motor speed drops for some reason, the lowered voltage in the sensor coil allows the bi-metal contacts to re-close, supplying start winding current to bring the motor back to operation speed.

Reverse Impact Torque:

This unique torque reversing feature will minimize the problems of polluted environments. In a locked rotor condition, the BIAC switch will supply full start winding current for approximately one second. Then the switch begins to open and close rapidly. This action chops the start winding current, switching it between leading and lagging the run winding current. This produces impact torque in both forward and reverse directions.

This reverse impact torque will literally shake and loosen many obstructions. Once cleared, the motor will run in proper rotation.

Extreme Fast Cycling:

(Due to Water - Logged Tank)

The BIAC starting switch will reset within approximately 5 seconds after the motor is stopped. If an attempt is made to restart the motor before the starting switch has reset, the motor may not start; however, there will be current flow through the main winding until the overload protector interrupts the circuit. The reset time for the protector is longer than the reset of the starting switch. So, the start winding switch will have closed and the motor will operate. The repeated on-off cycle will continue until the overload will trip again.

When a severely water – logged condition does occur, the user will be alerted to the problem during the off time (overload reset time), since the pressure will drop dramatically. When a water – logged tank condition is detected, the condition should be corrected to prevent nuisance tripping of the overload protector.

Bound Pump (sand-locked):

When the motor is not free to turn, as with a sand-locked pump, the BIAC switch creates a “reverse impact torque “ as described above. This is a unique feature, particularly interesting in sandy environments or applications where long stand-still periods are to be expected (seasonal usage of water).

4" SUPER STAINLESS MOTOR - 2-WIRE DESIGN

MOTOR MODEL NUMBERS 50 HZ - 2-WIRE DESIGN

P _N [kW]	U _N [V]	Digit 1 - 6	Digit 7 - 10	
			Single pack, with lead*	Motors in 40 motors packing unit
0,37	220-230	244 755	6721L	6721
0,55	220-230	244 757	6721L	6721
0,75	220-230	244 758	6721L	6721
1,1	220-230	244 759	6721L	6721

* lead lengths motors: "L": 1.50 m preassembled cable

MOTOR PERFORMANCE DATA 50 HZ - 2-WIRE DESIGN

P _N [kW]	Thrust F [N]	U _N [V]	n _N [min ⁻¹]	I _N [A]	I _A [A]	η (Eff.) [%] at % load			cos φ (Pf.) at % load			T _N [Nm]	T _A [Nm]
						50	75	100	50	75	100		
						0,37	4000	220	2875	4,1	24,4		
		230	2890	4,1	25,5	47	54	57	0,53	0,64	0,73	1,23	1,29
0,55	4000	220	2870	5,7	35,0	50	57	59	0,55	0,67	0,77	1,85	1,7
		230	2890	5,8	36,6	47	55	59	0,51	0,63	0,73	1,85	1,9
0,75	4000	220	2875	7,2	46,6	54	61	62	0,57	0,69	0,78	2,5	2,1
		230	2890	7,3	48,7	51	59	61	0,53	0,65	0,75	2,5	2,3
1,10	4000	220	2880	10,6	57,9	56	62	63	0,56	0,68	0,77	3,7	2,7
		230	2895	10,8	59,7	52	60	63	0,51	0,63	0,73	3,7	2,9

WINDING RESISTANCE DATA 50 HZ 220-230V - 2-WIRE DESIGN

P _N [kW]	U _N [V]	Stator-Ref.	Main phase [Ohm]
0,37	220 - 230	326 821 ***	7,2 - 8,8
0,55	220 - 230	326 822 ***	5,0 - 6,1
0,75	220 - 230	326 823 ***	3,6 - 4,4
1,10	220 - 230	326 823 ***	2,3 - 2,8

MOTOR DESIGN AND DIMENSIONS

MOTORDSIGN 304SS 0,37 - 1,1 kW

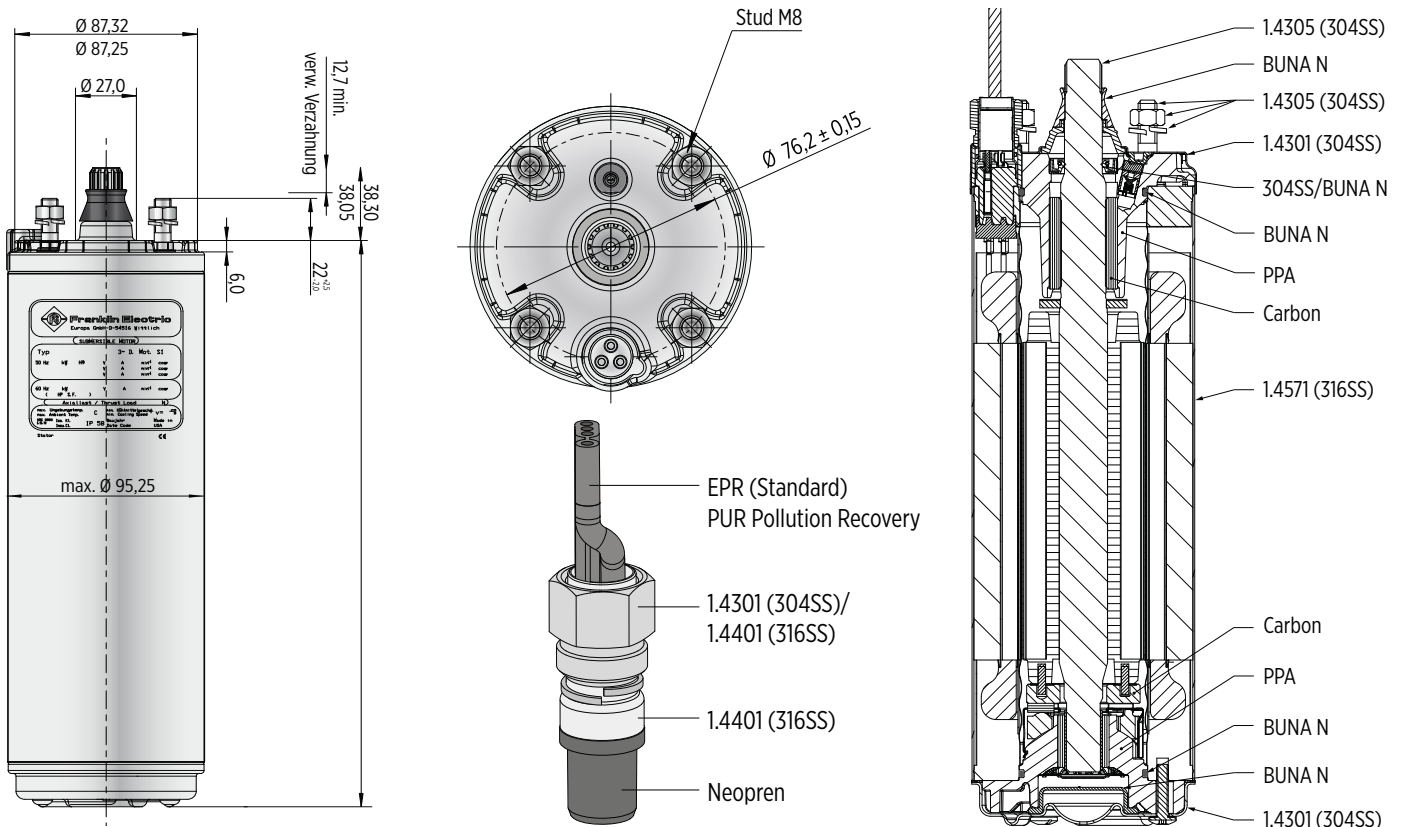

Toleranzen laut NEMA MG 1-18.388

LENGTHS AND WEIGHTS - 2-WIRE DESIGN

P_N		L [mm]	M [kg]	motor with lead in single pack	
[kW]	[HP]			[mm]	[kg]
0,37	0,50	228,2	6,7	400 x 100 x 110	7,1
0,55	0,75	248,2	7,6	400 x 100 x 110	7,9
0,75	1,00	282,6	8,8	530 x 100 x 110	9,1
1,10	1,50	338,6	11,3	530 x 100 x 110	11,6

MOTOR LEADS 2-WIRE

2-wire motor leads		
0,37 - 1,1 kW		
\varnothing [mm ²]	B [mm]	H [mm]
3X1,5	10,7 ± 0,3	5,0 ± 0,3

L [m]	Model numbers 304SS
1,5	310 134 401
2,5	310 134 402
5	310 134 405
10	310 134 410
15	310 134 415
20	310 134 420
30	310 134 430

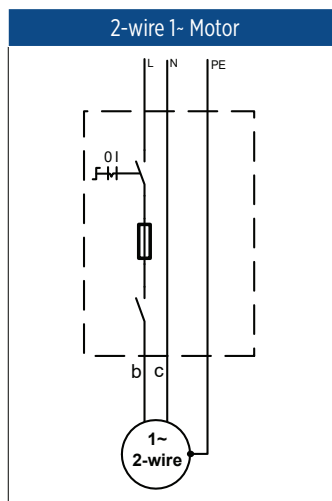

a = black | b = brown | c = grey | PE = yellow/green

MOTOR PART DESCRIPTION

MOTOR DESIGN 0.37 - 1.1 KW

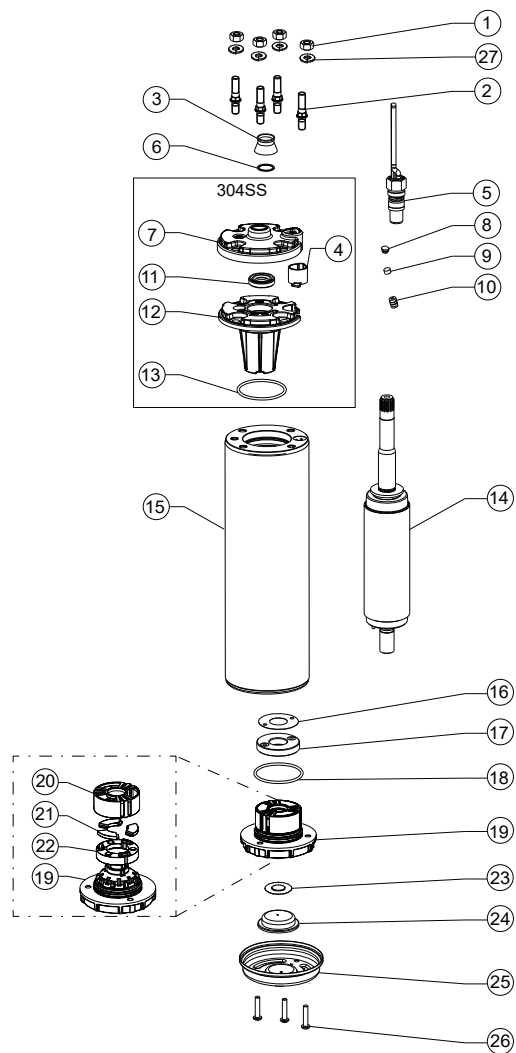

Pos.	Part Description	Qty.	Part No.
1	Nut	4	Kit C
2	Stud	4	Kit C
3	Protector, Spline	1	Kit B
4	Connector boss	1	151 820 103
5	Motor Lead	1	Page 15
6	Washer	1	Kit B
7	Top Endbell, Cover 304SS	1	150 262 151
8	Filter plug	1	Kit
9	Filter	1	Kit
10	Valve	1	Kit
11	Shaft Seal	1	Kit B
12	Top Endbell	1	Kit
13	O-Ring	1	Kit B
14	Rotor	1	Page 16
15	Stator	1	Page 16
16	Level washer	1	Kit A2
17	Thrust disk assy	1	Kit A2
18	O-Ring	1	Kit B / Kit A2
19	Bottom Endbell	1	Kit A2
20	Bearing cage	1	Kit A2
21	Segments	3	Kit A2
22	Gasket	1	Kit A2
23	Diaphragm washer	1	151 314 101 / Kit A2
24	Diaphragm	1	Kit B / Kit A2
25	Bottom Endbell Cover 304SS	1	156 414 201 / Kit A2
26	Screw, Cover	3	Kit C
27	Lock washer	4	Kit C

SPARE PARTS KITS

P_N [kW]	0.25 - 3.0 kW		
Kit A1	Top Endbell 304SS	incl. pos. 4, 7, 8, 9, 10, 11, 12, 13	308 462 902
Kit A2	Bottom Endbell 304SS incl. Thrust Bearing Kit 4000N	incl. pos. 16 - 22	308 464 911
Kit B	Seal Kit Standard 304SS	incl. pos. 3, 6, 8, 9, 11, 13, 18, 23, 24	308 650 201
	Seal Kit Pollution Recovery 304SS		308 650 202
Kit C	Fastener Kit 304SS	incl. pos. 1, 2, 26, 27	308 656 202

SPARE PARTS 2-WIRE DESIGN - STATOR AND ROTOR 0.37 - 1.1 KW

P_N [kW]	U_N [V]	Model no. stator 304SS	Model no. rotor 304SS
0,37	220 / 230	305 491 881	178 164 902K
0,55	220 / 230	305 491 882	178 164 903K
0,75	220 / 230	305 491 883	178 164 905K
1,1	220 / 230	305 491 884	178 164 908K