

SUBMERSIBLE MOTORS SYSTEMS, DRIVES AND ACCESSORIES



MOVING WATER IS OUR BUSINESS



8" ENCAPSULATED MOTOR

High-quality encapsulated motor with hermetically-sealed windings



FEATURES & BENEFITS

- Double flange NEMA mounting design
- Stainless steel splined shaft
- StatorShield™ - Franklin encapsulation system
- Factory filled with Franklin's FES91 motor fill solution for frost protection down to -15 °C storage temperature.
- Liquid lubricated radial bearings and High capacity Kingsbury type 45 kN thrust bearing for 100 % maintenance free operation
- Field replaceable lead using Franklin's exclusive Water Bloc technology
- Pressure-equalizing diaphragm, spring pre-loaded
- SandFighter™ sealing system with SIC mechanical seal and sand slinger
- High efficiency electrical design for low operation costs
- Standard Motor: WW- Water well Design (Stator 304SS / Castings - CI Powder coated)
- Drinking water approvals

STANDARD SPECIFICATION

- Ratings: 30 - 150 kW
- Max. storage temperature - 15 °C to + 60 °C
- Nominal ambient temperature: 30 °C (with 0.16 m/s cooling flow)
- Standard Voltage:
50 Hz: - 10 % / + 6 % U_N [(380 - 10 %) - (415 + 6 %)]
60 Hz: $\pm 10 \% U_N$ [460 V]
- Protection IP68 and insulation class F
- Motor protection: DIN 61947-4-1
- Frequency of starts: 10 starts/ hour (with min. 3 minutes resting time), equally distributed
- DOL / Y Δ - start (pos. of cables 90 °)
- Motor lead length: 4 m
- Installation orientation: Vertical / horizontal (shaft end heightened)
- Rotation counter clock wise facing shaft end (Rotation reversible)
- Integrated sensor for SubMonitor™
 - ▶ SubMonitor™ Protection

OPTIONS

- Higher-graded materials: 316SS
- Special voltages
- Retrofittable PT 100 temperature sensor



MOTOR MODEL NUMBERS 50 HZ - 3-PHASEN DESIGN

P _N [kW]	U _N [V]	Model number Digit 1 - 6		Model number Digit 7 - 10 with SubMonitor Transmitter			
		DOL	YΔ	WW**		316 SS	
				DOL	YΔ	DOL	YΔ
30	380, 400, 415	239 600	239 620	7023	8023	7223	8223
	500,525	239 670	239 720	7023	8023	-	-
37	380, 400, 415	239 601	239 621	7023	8023	7223	8223
	500,525	239 671	239 721	7023	8023	-	-
45	380, 400, 415	239 602	239 622	7023	8023	7223	8223
	500,525	239 672	239 722	7023	8023	-	-
55	380, 400, 415	239 603	239 623	7043	8043	7243	8243
	500,525	239 673	239 723	7043	8043	-	-
75	380, 400, 415	239 604	239 624	7043	8043	7243	8243
	500,525	239 674	239 724	7043	8043	-	-
93	380, 400, 415	239 105	239 125	7019	8019	7219	8219
	500,525	239 175	239 225	7019	8019	-	-
110	380, 400, 415	239 106	239 126	7519	7619	7219	8219
	500,525	239 176	239 226	7519	7619	-	-
130	380, 400, 415	239 107	239 127	7519	7619	7219	8219
	500,525	239 177	239 227	7519	7619	-	-
150	380, 400, 415	239 108	239 128	7519	7619	7219	8219
	500,525	239 178	239 228	7519	7619	-	-

* VFD operation is only allowed up to 400V supply voltage, for higher voltages please consult Franklin Electric Europa GmbH

** WW (Water well)- Stator 304SS / Castings - CI Powder coated

MOTOR MODEL NUMBERS 60 HZ - 3-PHASEN DESIGN

P _N [kW]	P _{max.} [kW]	U _N [V]	Model number Digit 1 - 6		Model number Digit 7 - 10 with SubMonitor Transmitter			
			DOL	YΔ	WW*		316 SS	
					DOL	YΔ	DOL	YΔ
30	40	230	-	239 650	-	8023	7223	8223
		380	239 660	239 680	7023	8023	7223	8223
		460	239 600	239 620	7023	8023	7223	8223
		575	239 610	-	7023	8023	7223	8223
37	50	230	-	239 651	-	8023	7223	8223
		380	239 661	239 681	7023	8023	7223	8223
		460	239 601	239 621	7023	8023	7223	8223
		575	239 611	-	7023	8023	7223	8223
45	57,8	230	-	239 652	-	8023	7223	8223
		380	239 662	239 682	7023	8023	7223	8223
		460	239 602	239 622	7023	8023	7223	8223
		575	239 612	-	7023	8023	7223	8223
55	64	230	-	239 653	-	8043	7243	8243
		380	239 663	239 683	7043	8043	7243	8243
		460	239 603	239 623	7043	8043	7243	8243
		575	239 613	-	7043	8043	7243	8243
75	86	230	-	239 654	-	8043	7243	8243
		380	239 664	239 684	7023	8043	7243	8243
		460	239 604	239 624	7023	8043	7243	8243
		575	239 614	-	7023	8043	7243	8243
93	107	380	239 165	239 185	7019	8019	7219	8219
		460	239 105	239 125	7019	8019	7219	8219
		575	239 115	-	7019	8019	7219	8219
110	128	380	239 166	239 186	7519	7619	7219	8219
		460	239 106	239 126	7519	7619	7219	8219
		575	239 116	-	7519	7619	7219	8219
130	150	380	239 167	239 187	7519	7619	7219	8219
		460	239 107	239 127	7519	7619	7219	8219
		575	239 117	-	7519	7619	7219	8219
150	170	380	239 168	239 188	7519	7619	7219	8219
		460	239 108	239 128	7519	7619	7219	8219
		575	239 118	-	7519	7619	7219	8219

* WW (Water well)- Stator 304SS / Castings - CI Powder coated

MOTOR PERFORMANCE DATA 50 HZ - 3-PHASEN DESIGN

P _N [kW]	Thrust F [N]	U _N [V]	n _N [min ⁻¹]	I _N [A]	I _A [A]	η (Eff.) [%] at % load			cos φ (Pf.) at % load			T _N [Nm]	T _A [Nm]
						50	75	100	50	75	100		
30	45 000	380	2890	61	397	85	86	86	0,75	0,84	0,88	98	231
		400	2900	61	418	83	86	86	0,68	0,78	0,84	97	255
		415	2910	62	433	82	85	86	0,62	0,73	0,80	97	275
		500	2890	47	302	85	86	86	0,75	0,84	0,88		
		525	2900	47	318	83	86	86	0,68	0,78	0,84		
37	45 000	380	2905	75	507	85	87	87	0,78	0,85	0,89	122	266
		400	2920	74	534	84	87	87	0,71	0,81	0,86	121	295
		415	2925	74	554	83	86	87	0,66	0,76	0,83	121	317
		500	2905	57	385	85	87	87	0,78	0,85	0,89		
		525	2920	57	404	84	87	87	0,71	0,81	0,86		
45	45 000	380	2910	89	612	86	87	87	0,77	0,85	0,89	146	363
		400	2920	89	645	85	87	87	0,71	0,81	0,85	145	395
		415	2925	89	669	84	86	87	0,65	0,76	0,82	146	428
		500	2910	68	466	86	87	87	0,77	0,85	0,89		
		525	2920	68	494	85	87	87	0,71	0,81	0,85		
55	45 000	380	2910	111	819	86	88	88	0,79	0,86	0,89	182	507
		400	2920	108	862	85	87	88	0,72	0,82	0,87	182	563
		415	2925	108	895	84	87	88	0,67	0,78	0,84	182	605
		500	2910	85	623	86	88	88	0,79	0,86	0,89		
		525	2920	83	661	85	87	88	0,72	0,82	0,87		
75	45 000	380	2920	153	1208	86	87	87	0,71	0,81	0,86	243	637
		400	2930	153	1272	85	87	87	0,63	0,75	0,81	242	706
		415	2935	156	1319	84	87	87	0,57	0,70	0,77	242	760
		500	2920	113	835	86	88	88	0,79	0,86	0,89		
		525	2925	111	861	85	87	87	0,72	0,82	0,87		
93	45 000	380	2920	194	1265	85	87	87	0,75	0,83	0,86	303	511
		400	2930	190	1332	84	86	87	0,68	0,78	0,83	302	567
		415	2935	191	1382	83	86	87	0,63	0,74	0,80	302	610
		500	2920	148	961	85	87	87	0,75	0,83	0,86		
		525	2930	145	1015	84	86	87	0,68	0,78	0,83		
110	45 000	380	2920	226	1517	86	88	88	0,77	0,84	0,87	364	694
		400	2930	222	1597	85	87	88	0,70	0,80	0,84	363	769
		415	2935	223	1657	84	87	88	0,64	0,75	0,81	363	828
		500	2920	172	1153	86	88	88	0,77	0,84	0,87		
		525	2930	170	1217	85	87	88	0,70	0,80	0,84		
130	45 000	380	2910	260	1651	86	87	87	0,83	0,87	0,89	425	837
		400	2920	252	1738	86	87	88	0,79	0,84	0,87	424	927
		415	2930	247	1803	85	87	88	0,74	0,81	0,86	423	1153
		500	2910	198	1255	86	87	87	0,83	0,87	0,89		
		525	2920	192	1324	86	87	88	0,79	0,84	0,87		
150	45 000	380	2910	294	1765	86	88	88	0,83	0,88	0,90	487	933
		400	2920	284	1858	86	88	88	0,79	0,86	0,88	485	1034
		415	2930	277	1928	86	88	88	0,75	0,83	0,87	485	1113
		500	2910	224	1341	86	88	88	0,83	0,88	0,90		
		525	2920	217	1416	86	88	88	0,79	0,86	0,88		

MOTOR PERFORMANCE DATA 60 HZ - 3-PHASEN DESIGN

P_N [kW]	$P_{max.}$ [kW]	Thrust F [N]	U_N [V]	HZ	n_N [min ⁻¹]	$I_{max.}$ [A]	I_A [A]	η_{max} [%] at % load	LINE TO LINE RESISTANCE [Ω]
30	40	45000	380	60	3525	72	479	86	.16-.20
			460	60	3525	60	396	86	.24-.30
			575	60	3525	48	317	86	.39-.49
37	50	45000	380	60	3525	88	656	87	.12-.16
			460	60	3525	73	542	87	.18-.22
			575	60	3525	59	434	87	.28-.34
45	57,8	45000	380	60	3525	104	797	87	.09-.11
			460	60	3515	86	658	88	.14-.17
			575	60	3525	69	526	87	.22-.28
55	64	45000	380	60	3525	130	1046	88	.06-.09
			460	60	3515	107	864	88	.10-.13
			575	60	3525	86	691	88	.16-.21
75	86	45000	380	60	3525	172	1466	89	.05-.06
			460	60	3520	142	1211	87	.07-.09
			575	60	3525	114	969	89	.11-.13
93	107	45000	380	60	3525	228	1596	86	.03-.04
			460	60	3520	188	1318	84	.05-.07
			575	60	3525	151	1054	86	.08-.11
110	128	45000	380	60	3525	266	1961	87	.02-.03
			460	60	3520	219	1620	86	.04-.05
			575	60	3525	176	1296	87	.06-.08
130	150	45000	380	60	3525	302	1991	88	.02-.04
			460	60	3515	249	1645	88	.04-.05
			575	60	3525	200	1316	88	.06-.08
150	170	45000	380	60	3525	342	2270	88	.02-.03
			460	60	3510	282	1875	89	.03-.05
			575	60	3525	226	1500	88	.05-.07

ELECTRICAL CONNECTION - 3-PHASE DESIGN

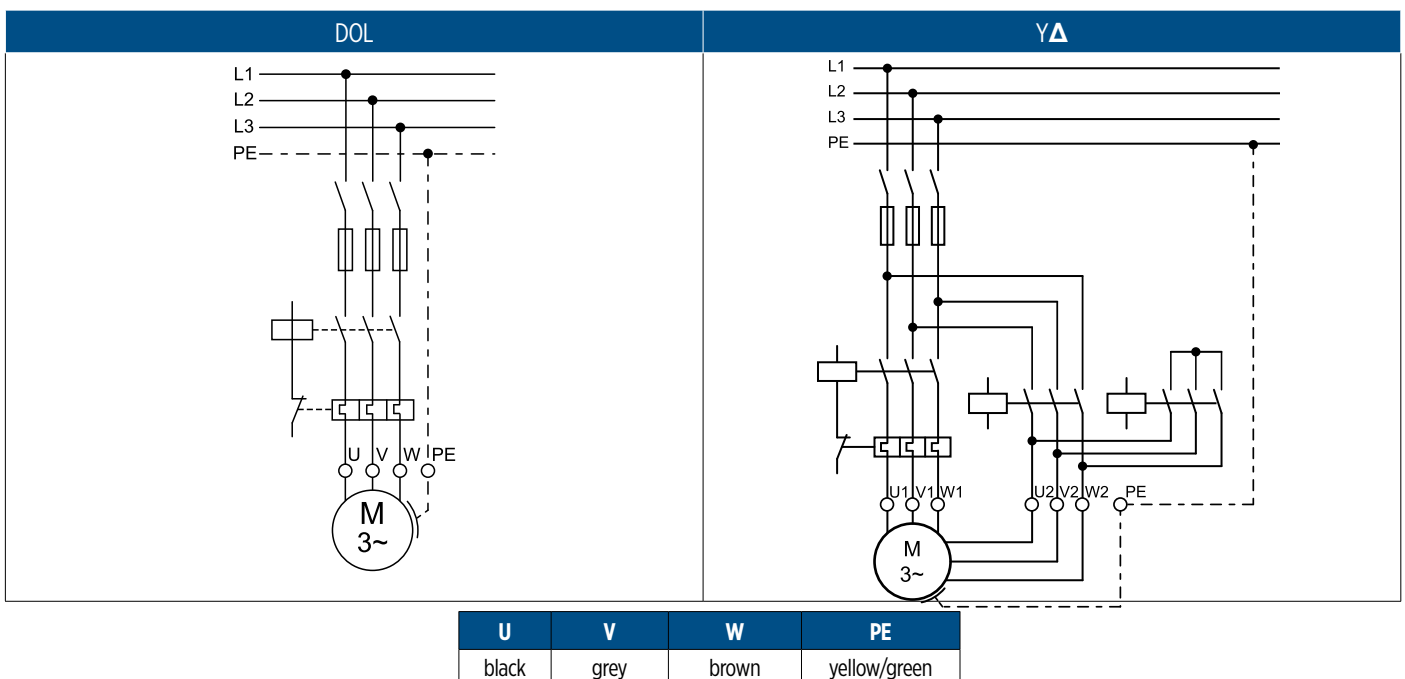

WINDING RESISTANCE DATA 50 HZ - 3-PHASE DESIGN

P _N [kW]	U _N [V]	3 - DOL		3 - YΔ	
		Stator Ref.	U - V / Ohm V - W / Ohm U - W / Ohm	Stator Ref.	U ₁ - U ₂ / Ohm V ₁ - V ₂ / Ohm W ₁ - W ₂ / Ohm
30	220	-	-	338 382 ...	0.123 - 0.150
	380, 400, 415	338 382 ...	0.247 - 0.302	338 443 ...	0.345 - 0.423
	500, 525	338 610 ...	0.399 - 0.487	338 610 ...	0.621 - 0.759
37	220	-	-	338 383 ...	0.090 - 0.111
	380, 400, 415	338 383 ...	0.181 - 0.221	338 588 ...	0.272 - 0.332
	500, 525	338 611 ...	0.280 - 0.342	338 611 ...	0.464 - 0.566
45	220	-	-	338 384 ...	0.071 - 0.087
	380, 400, 415	338 384 ...	0.142 - 0.174	338 645 ...	0.210 - 0.257
	500, 525	338 612 ...	0.227 - 0.277	338 612 ...	0.369 - 0.450
55	220	-	-	338 385 ...	0.053 - 0.065
	380, 400, 415	338 385 ...	0.105 - 0.128	338 646 ...	0.164 - 0.200
	500, 525	338 613 ...	0.169 - 0.207	338 613 ...	0.267 - 0.327
75	220	-	-	338 386 ...	0.036 - 0.045
	380, 400, 415	338 386 ...	0.073 - 0.089	338 591 ...	0.102 - 0.125
	500, 525	338 614 ...	0.129 - 0.158	338 614 ...	0.198 - 0.243
93	380,400,415	336 053 ...	0.055 - 0.067	336 053 ...	0.083 - 0.101
	500, 525	338 514 ...	0.091 - 0.112	338 514 ...	0.137 - 0.168
	380,400,415	336 054 ...	0.046 - 0.056	336 054 ...	0.069 - 0.084
110	500, 525	338 515 ...	0.086 - 0.106	338 515 ...	0.129 - 0.159
	380,400,415	336 524 ...	0.042 - 0.052	336 524 ...	0.063 - 0.078
130	500, 525	338 516 ...	0.073 - 0.090	338 516 ...	0.110 - 0.135
	380,400,415	336 055 ...	0.036 - 0.044	336 055 ...	0.054 - 0.066
150	500, 525	337 071 ...	0.057 - 0.070	337 071 ...	0.086 - 0.105

VDE / KTW Approved Leads* WW / 316SS

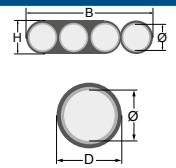
3 - DOL start								
	P _N [kW]	Ø [mm ²]	Size [mm]	Type	Qty.	L (m)	Part numbers	
							WW	316SS
	30 - 45	3X8,4 + 1G8,4 mm ²	B 29,5 / H 8,9	VDE/КТW	1	8	305 312 901	305 312 911
		3 x (1X16 mm ²)	D 11,6 (±0,2)	VDE/КТW	1	8	305 310 901	305 310 951
	110 - 150*	3 x (1X35 mm ²)	Ø 14,5 (±0,3)	VDE/КТW	1	8	305 309 901	

* 3 Leads with single conductors

3 - YΔ Start (Pos. of cables 90°)

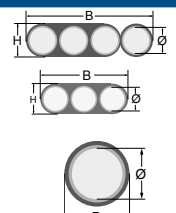
3 - YΔ Start (Pos. of cables 90°)								
	P _N [kW]	Ø [mm ²]	Size [mm]	Type	Qty.	L (m)	Part numbers	
							WW	316SS
	30 - 45	3X8,4 + 1G8,4 mm ²	B 29,5 / H 8,9	VDE/КТW	1	8	305 312 902	305 312 912
		1x 3X8,4 mm ²	B 19,6 / H 8,9		1			
	55 - 150	3 x (1X16 mm ²)	D 11,6 (±0,2)	VDE/КТW	2	8	305 310 901	305 310 951

Ground Leads

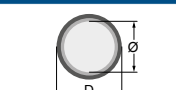
Ground Leads								
	P _N [kW]	Ø	Size [mm]	Type	Qty.	L (m)	Part numbers	
							WW/316SS	
	55 - 150	1G25 mm ²	D 13 mm (±0,3)	VDE/КТW	1	8	308 053 080	

* Cables are designed for submerged operation. For air operation please consult Franklin Electric.

8" Encapsulated Standard Motor WW Design

30 - 45 kW Type 2.1***

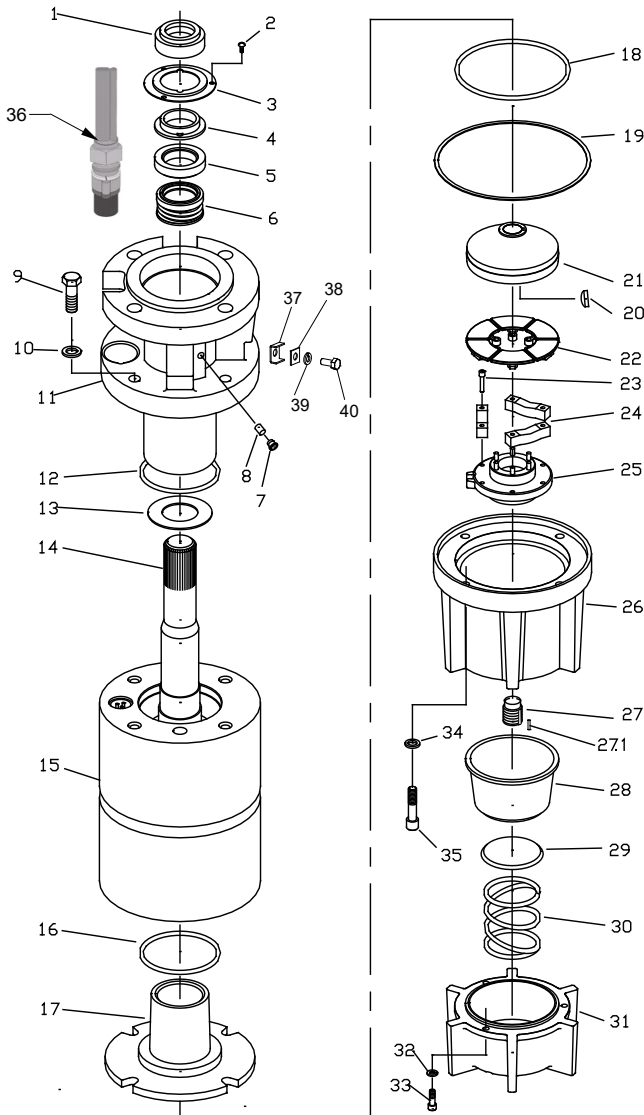

Position	Part Description	Qty	Kit
1	Rubber Slinger	1	B
2	Bushing Cover Screw	3	B, F
3	Bushing Cover	1	B
4	Slinger Bushing	1	B
5, 6	Shaft Seal	1	B
7	Filter Assembly	1	B
8	Valve Assembly	1	B
9, 10	Screw/Lockwasher	4	C, D, F
11	End Bell, Upper w/Radial Brg	1	C, D
12	O-Ring	1	B, C, D
13	Upthrust Washer	1	A
14	Rotor	1	see page 122/123
15	Stator	1	see page 122/123
16	O-Ring	1	B, E
17	End Bell, Lower w/Radial Brg	1	E
18	O-Ring	1	B, E
19	Gasket	1	B
20	Woodruff Key	1	A
21	Thrust Disc Asm	1	A
22, 23, 24, 25	Thrust Segment Asm	1	A
26	Thrust Housing	1	G
27	Adjusting Screw	1	A
27.1	Pin (Brass)	1	A
28	Diaphragm	1	B
29	Spring Plate	1	B
30	Diaphragm Spring	1	B
31	Diaphragm Cover	1	H
32, 33	Screw/Lockwasher	3	F, H
34, 35	Screw/Lockwasher	4	F, G
36	Lead	1/2	see page 119
37	U - Clip	1	152 283 101
38	Washer	1	275 609 101
39	Lockwasher	1	275 606 110
40	Ground screw	1	276 015 102

	Description	Includes Pos.	Part Number
Kit A 40 - 60 HP	Thrust Bearing	13, 19 - 25, 27, 27.1	305 428 001
Kit B1 40 - 60 HP	Seal SiC	1 - 8, 12, 16, 18, 19, 28 - 30	305 428 011
Kit C1 40 - 60 HP 3 Lead	End Bell, Upper	9 - 12	305 428 003
Kit D1 40 - 60 HP 6 Lead	End Bell, Upper	9 - 12	305 428 005
Kit E 40 - 60 HP	End Bell, Lower*	16 - 18	305 428 007
Kit F 40 - 60 HP	Fasteners*	2, 9, 10, 32 - 35	305 428 017
Kit G 40 - 60 HP	Thrust Housing	26, 34, 35	305 428 009
Kit H 40 - 60 HP	Diaphragm Cover	31 - 33	305 428 010
Kit I Type 2.1 Motors	Radial Bearing**	SS Sleeve & Carbon Bushing	305 428 054

* Suitable for WW and 316SS Motors

** Parts are Semi finished

*** Spare parts for motors build up to june 2015 please contact FE

8" Encapsulated Standard Motor WW Design

55 - 150 kW Type 1

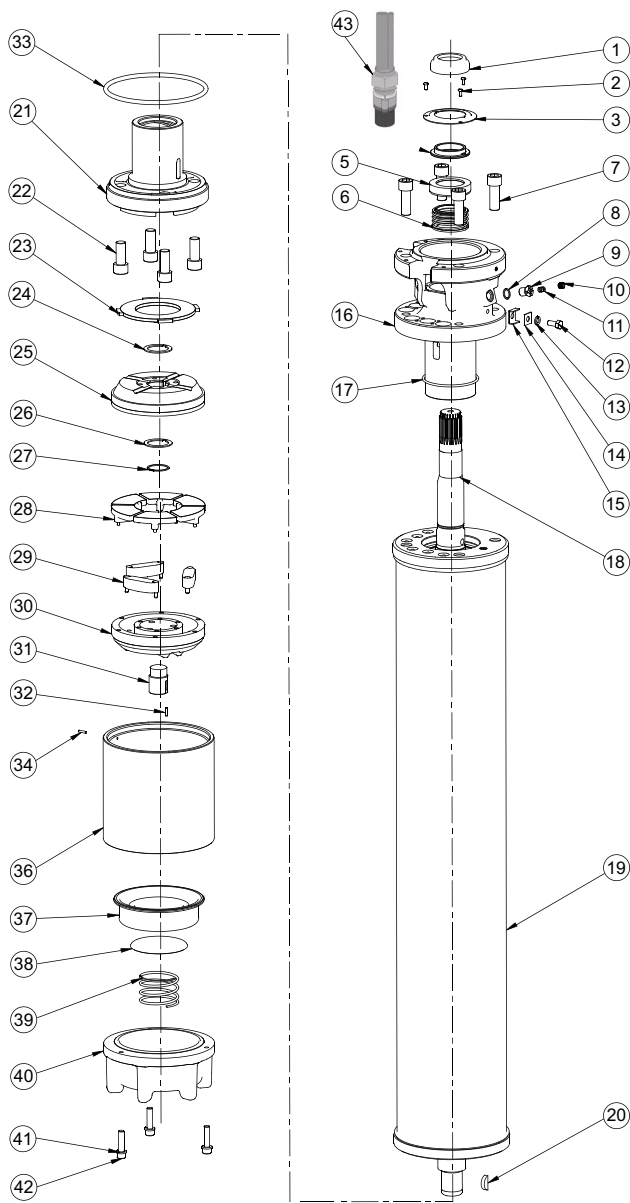

Position	Part Description	Qty	Kit
1	Rubber Slinger	1	B
2	Bushing Cover Screw	3	B, F
3	Bushing Cover	1	B
4	Slinger Bushing	1	B
5, 6	Shaft Seal	1	B
7	Screw/Lockwasher	4	C, D, F
8, 9, 11	Valve Assembly	1	B, C, D
10	Filter Assembly	1	B
12, 13, 14, 15	Ground Lug Asm	1	C, D
16	End Bell, Upper w/Radial Brg	1	C, D
17	O-Ring	1	B, C, D
18	Rotor	1	see page 122/123
19	Stator	1	see page 122/123
20	Woodruff Key	1	A
21	End Bell, Lower w/Radial Brg	1	E
22	Screw	4	E, F
23	Upthrust Washer	1	A 155 318 201K
24, 26, 27	Shim/Retainer Ring	1	A
25	Thrust Disc Asm	1	A
28, 29, 30	Thrust Segment Asm	1	A
31	Adjusting Screw	1	A
32	Pin	1	A
33	O-Ring	1	A, E
34	Pin (Brass) Ø5 x 14mm	1	G
36	Thrust Housing	1	G
35	Plug	1	--
37	Diaphragm	1	B
38	Spring Plate	1	B
39	Diaphragm Spring	1	B
40	Diaphragm Cover	1	H
41, 42	Screw/Lockwasher	3	F, H
43	Lead	3 / 6	see page 119

	Description	Includes Pos.	Part Number
Kit A 75 - 200 HP	Thrust Bearing	20, 23 - 33	305 428 020
Kit B1 75 - 200 HP	Seal Kit	1 - 6, 10, 11, 17, 32, 33, 37 - 39	305 428 021
Kit B2 75 - 200 HP	Seal SiC ***	1 - 6, 10, 11, 17, 32, 33, 37 - 39	305 428 022
Kit C1 75 HP 3 Lead	End Bell, Upper	7, 11 - 17	305 428 023
Kit C2 150 - 200 HP 3 Lead	End Bell, Upper	7, 11 - 17	305 428 024
Kit D 75 - 200 HP 6 Lead	End Bell, Upper	7, 11 - 17	305 428 025
Kit E 75 - 200 HP	End Bell, Lower*	21, 22, 32, 33	305 428 037
Kit F 75 - 200 HP	Fasteners*	2, 7, 22, 41, 42	305 428 039
Kit G 75 - 200 HP	Thrust Housing	34, 36	305 428 029
Kit H 75 - 200 HP	Diaphragm Cover	40 - 42	305 428 030
Kit I Type 1 Motors	Radial Bearing**	SS Sleeve & Carbon Bushing	305 428 055

* Suitable for WW and 316SS Motors

** Parts are Semi finished

*** Spring DM 62,7mm for 125 - 200 HP only

Replacement Stators and Rotors WW / 50 Hz

3 - Direct start with SubMonitor Transmitter

P_N [kW]	U_N [V]	Motor Model No.	Stator	Rotor
30	380, 400, 415	239 600 7023	305 500 901	575 122 925
	500, 525	239 670 7023	338 610 902	
37	380, 400, 415	239 601 7023	305 501 901	575 122 930
	500, 525	239 671 7023	338 611 903	
45	380, 400, 415	239 602 7023	305 502 901	575 122 931
	500, 525	239 672 7023	338 612 904	
55	380, 400, 415	239 603 7043	338 386 915	575 122 920
	500, 525	239 673 7043	338 613 902	
75	380, 400, 415	239 604 7043	338 386 915	575 122 921
	500, 525	239 674 7043	338 614 907	
93	380, 400, 415	239 105 7019	305 505 901	575 122 922
	500, 525	239 175 7019	338 514 951	
110	380, 400, 415	239 106 7519	305 506 902	575 122 923
	500, 525	239 176 7519	338 515 951	
130	380, 400, 415	239 107 7519	336 524 101	575 122 924
	500, 525	239 177 7519	*	
150	380, 400, 415	239 108 7519	336 055 905	575 122 918
	500, 525	239 178 7519	337 071 912	

Replacement Stators and Rotors WW / 50 Hz

3 - YΔ Start with SubMonitor Transmitter (Pos. of cables 90°)

P_N [kW]	U_N [V]	Motor Model No.	Stator	Rotor
30	220	239 400 8023	338 382 911	575 122 925
	380, 400, 415	239 620 8023	305 500 503	
	500, 525	239 720 8023	338 610 904	
37	220	239 401 8023	305 501 903	575 122 930
	380, 400, 415	239 621 8023	305 501 904	
	500, 525	239 721 8023	338 611 906	
45	220	239 402 8023	305 502 902	575 122 931
	380, 400, 415	239 622 8023	305 502 905	
	500, 525	239 722 8023	338 612 906	
55	220	239 403 8043	305 503 904	575 122 920
	380, 400, 415	239 623 8043	305 503 909	
	500, 525	239 723 8043	338 613 906	
75	220	239 404 8043	338 386 904	575 122 921
	380, 400, 415	239 624 8043	305 504 904	
	500, 525	239 724 8043	305 504 908	
93	380, 400, 415	239 125 8019	305 505 903	575 122 922
	500, 525	239 225 8019	305 505 910	
110	380, 400, 415	239 126 7619	305 506 903	575 122 923
	500, 525	239 226 7619	338 515 952	
130	380, 400, 415	239 127 7619	336 524 917	575 122 924
	500, 525	239 227 7619	338 516 902	
150	380, 400, 415	239 128 7619	336 055 919	575 122 918
	500, 525	239 228 7619	337 071 914	

Replacement Stators and Rotors - 3~ DOL 60 HZ - WW MOTORS

P_N [kW]	$P_{max.}$ [kW]	U_N [V]	Stator*	Rotor
30	40	230		575 122 925
		380		
		460		
		575		
37	50	230		575 122 930
		380		
		460		
		575		
45	57,8	230		575 122 931
		380		
		460		
		575		
55	64	230		575 122 932
		380		
		460		
		575		
75	86	230		575 122 917
		380		
		460		
		575		
93	107	380		575 122 922
		460		
		575		
110	128	380		575 122 923
		460		
		575		
130	150	380		575 122 924
		460		
		575		
150	170	380		575 122 918
		460		
		575		

* Spare parts stators 60 Hz on request

8" Encapsulated 316SS

30 - 45 kW Type 2.1***

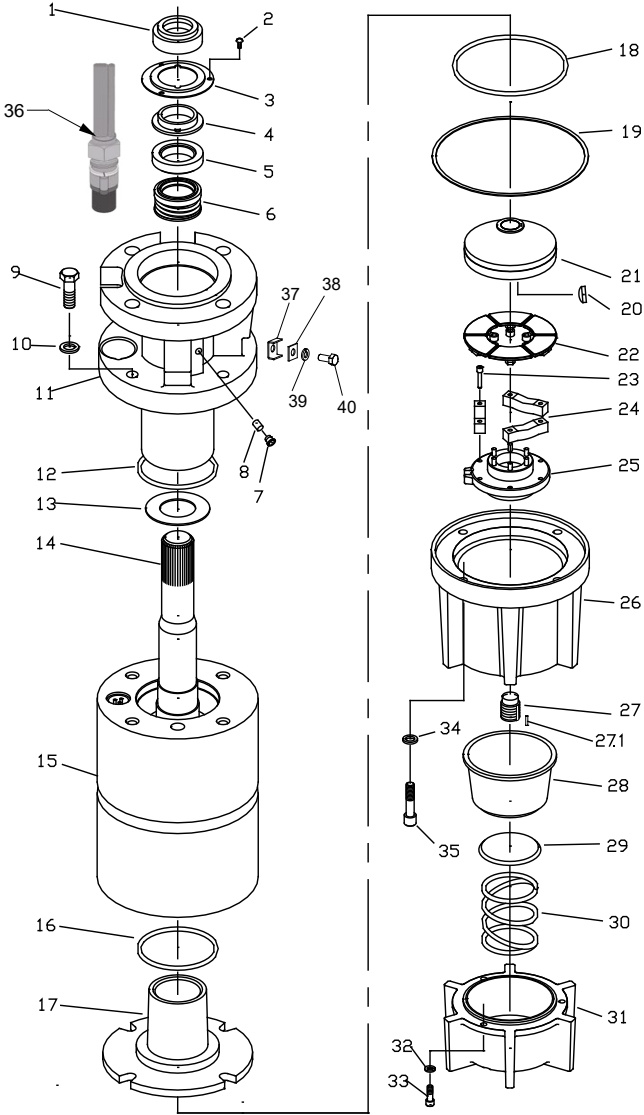

Position	Part Description	Qty	Kit
1	Rubber Slinger	1	B
2	Bushing Cover Screw	3	B, F
3	Bushing Cover	1	B
4	Slinger Bushing	1	B
5, 6	Shaft Seal	1	B
7	Filter Assembly	1	B
8	Valve Assembly	1	B
9, 10	Screw/Lockwasher	4	C, D, F
11	End Bell, Upper w/Radial Brg	1	C, D
12	O-Ring	1	B, C, D
13	Upthrust Washer	1	A, B1 155 941 101
14	Rotor	1	see page 126/127
15	Stator	1	see page 126/127
16	O-Ring	1	B, E
17	End Bell, Lower w/Radial Brg	1	E
18	O-Ring	1	B, E
19	Gasket	1	B
20	Woodruff Key	1	A
21	Thrust Disc Asm	1	A
22, 23, 24, 25	Thrust Segment Asm	1	A
26	Thrust Housing	1	G
27	Adjusting Screw	1	A
27.1	Pin (Brass)	1	A
28	Diaphragm	1	B
29	Spring Plate	1	B
30	Diaphragm Spring	1	B
31	Diaphragm Cover	1	H
32, 33	Screw/Lockwasher	3	F, H
34, 35	Screw/Lockwasher	4	F, G
36	Lead	1/2	see page 119
37	U - Clip	1	152 283 101
38	Washer	1	275 609 101
39	Lockwasher	1	275 606 110
40	Ground screw	1	276 015 102

	Description	Includes Pos.	Part Number
Kit A	40 - 60 HP Thrust Bearing*	13, 19 - 25, 27, 27.1	305 428 001
Kit B	40 - 60 HP Seal Kit	1 - 8, 12, 16, 18, 19, 28 - 30	305 428 012
Kit C1	40 - 60 HP 3 Lead End Bell, Upper	9 - 12	305 428 013
Kit D1	40 - 60 HP 6 Lead End Bell, Upper	9 - 12	305 428 015
Kit E	40 - 60 HP End Bell, Lower*	16 - 18	305 428 007
Kit F	40 - 60 HP Fasteners*	2, 9, 10, 32 - 35	305 428 017
Kit G	40 - 60 HP Thrust Housing	26, 34, 35	305 428 018
Kit H	40 - 60 HP Diaphragm Cover	31 - 33	305 428 019
Kit I	Type 2.1 Motors Radial Bearing**	SS Sleeve & Carbon Bushing	305 428 054

* Suitable for WW and 316SS Motors

** Parts are Semi finished

*** Spare parts for motors build up to june 2015 please contact FE

8" Encapsulated 316SS

55 - 150 kW Type 1

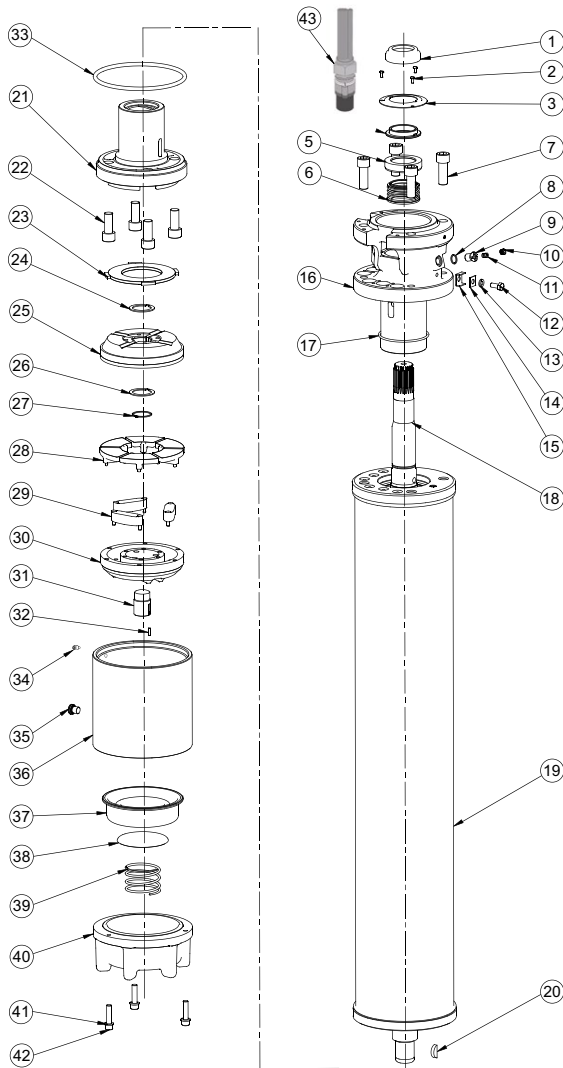

Position	Part Description	Qty	Kit
1	Rubber Slinger	1	B
2	Bushing Cover Screw	3	B, F
3	Bushing Cover	1	B
4	Slinger Bushing	1	B
5, 6	Shaft Seal	1	B
7	Screw/Lockwasher	4	C, D, F
8, 9, 11	Valve Assembly	1	B, C, D
10	Filter Assembly	1	B
12, 13, 14, 15	Ground Lug Asm	1	C, D
16	End Bell, Upper w/Radial Brg	1	C, D
17	O-Ring	1	B, C, D
18	Rotor	1	see page 126/127
19	Stator	1	see page 126/127
20	Woodruff Key	1	A
21	End Bell, Lower w/Radial Brg	1	E
22	Screw	4	E, F
23	Upthrust Washer	1	A
24, 26, 27	Shim/Retainer Ring	1	A
25	Thrust Disc Asm	1	A
28, 29, 30	Thrust Segment Asm	1	A
31	Adjusting Screw	1	A
32	Pin	1	A
33	O-Ring	1	A, E
34	Pos.- Screw	1	282 560 101 / G
35	Screw Plug (only 316ss Motor)	1	156 409 101
36	Thrust Housing	1	G
37	Diaphragm	1	B
38	Spring Plate	1	B
39	Diaphragm Spring	1	B
40	Diaphragm Cover	1	H
41, 42	Screw/Lockwasher	3	F, H
43	Lead	3 / 6	see page 119

	Description	Includes Pos.	Part Number
Kit A	75 - 200 HP Thrust Bearing	20, 23 - 33	305 428 020
Kit B	75 - 200 HP Seal SiC***	1 - 6, 10, 11, 17, 32, 33, 37 - 39	305 428 033
Kit C1	75 HP 3 Lead End Bell, Upper	7, 11 - 17	305 428 034
Kit C2	150 - 200 HP 3 Lead End Bell, Upper	7, 11 - 17	305 428 035
Kit D	75 - 200 HP 6 Lead End Bell, Upper	7, 11 - 17	305 428 036
Kit E	75 - 200 HP End Bell, Lower*	21, 22, 32, 33	305 428 037
Kit F	75 - 200 HP Fasteners*	2, 7, 22, 41, 42	305 428 039
Kit G	75 - 200 HP Thrust Housing	34, 35, 36	305 428 040
Kit H	75 - 200 HP Diaphragm Cover	40 - 42	305 428 041
Kit I	Type 1 Motors Radial Bearing**	SS Sleeve & Carbon Bushing	305 428 055

* Suitable for WW and 316SS Motors
 ** Parts are Semi finished
 *** Spring DM 62,7mm for 125 - 200 HP only

Replacement Stators and Rotors 316SS/ 50 Hz

3 ~ Direct start with SubMonitor Transmitter

P_N [kW]	U_N [V]	Motor Model No.	Stator	Rotor
30	380, 400, 415	239 600 7223	305 500 902	575 122 925
37	380, 400, 415	239 601 7223	305 501 902	575 122 930
45	380, 400, 415	239 602 7223	305 502 903	575 122 931
55	380, 400, 415	239 603 7243	338 385 915	575 122 920
75	380, 400, 415	239 604 7243	338 386 915	575 122 921
93	380, 400, 415	239 105 7219	305 505 902	575 122 922
110	380, 400, 415	239 106 7219	305 506 906	575 122 923
130	380, 400, 415	239 107 7219	336 524 915	575 122 924
150	380, 400, 415	239 108 7219	336 055 916	575 122 918

3 ~ YΔ Start with SubMonitor Transmitter (Pos. of cables 90°)

P_N [kW]	U_N [V]	Motor Model No.	Stator	Rotor
30	380, 400, 415	239 620 8223	338 443 904	575 122 925
37	380, 400, 415	239 621 8223	338 588 904	575 122 930
45	380, 400, 415	239 622 8223	305 502 906	575 122 931
55	380, 400, 415	239 623 8223	305 503 910	575 122 920
75	380, 400, 415	239 624 8223	305 504 905	575 122 921
93	380, 400, 415	239 125 8219	305 505 904	575 122 922
110	380, 400, 415	239 126 8219	305 506 905	575 122 923
130	380, 400, 415	239 127 8219	336 524 918	575 122 924
150	380, 400, 415	239 128 8219	305 508 904	575 122 918

Replacement Stators and Rotors - 3~ DOL 60 HZ - WW MOTORS

P_N [kW]	$P_{max.}$ [kW]	U_N [V]	Stator*	Rotor
30	40	230		575 122 925
		380		
		460		
		575		
37	50	230		575 122 930
		380		
		460		
		575		
45	57,8	230		575 122 931
		380		
		460		
		575		
55	64	230		575 122 932
		380		
		460		
		575		
75	86	230		575 122 917
		380		
		460		
		575		
93	107	380		575 122 922
		460		
		575		
110	128	380		575 122 923
		460		
		575		
130	150	380		575 122 924
		460		
		575		
150	170	380		575 122 918
		460		
		575		

* Spare parts stators 60 Hz on request

8" Outline Drawings WW / 316 SS

30 - 45 kW

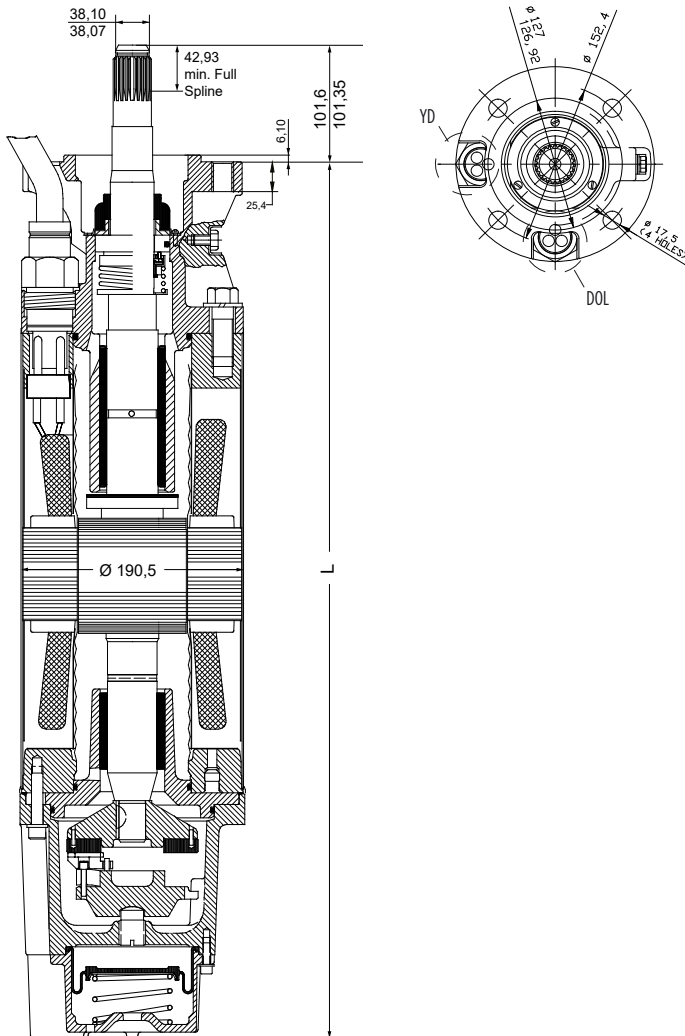

55 - 150 kW

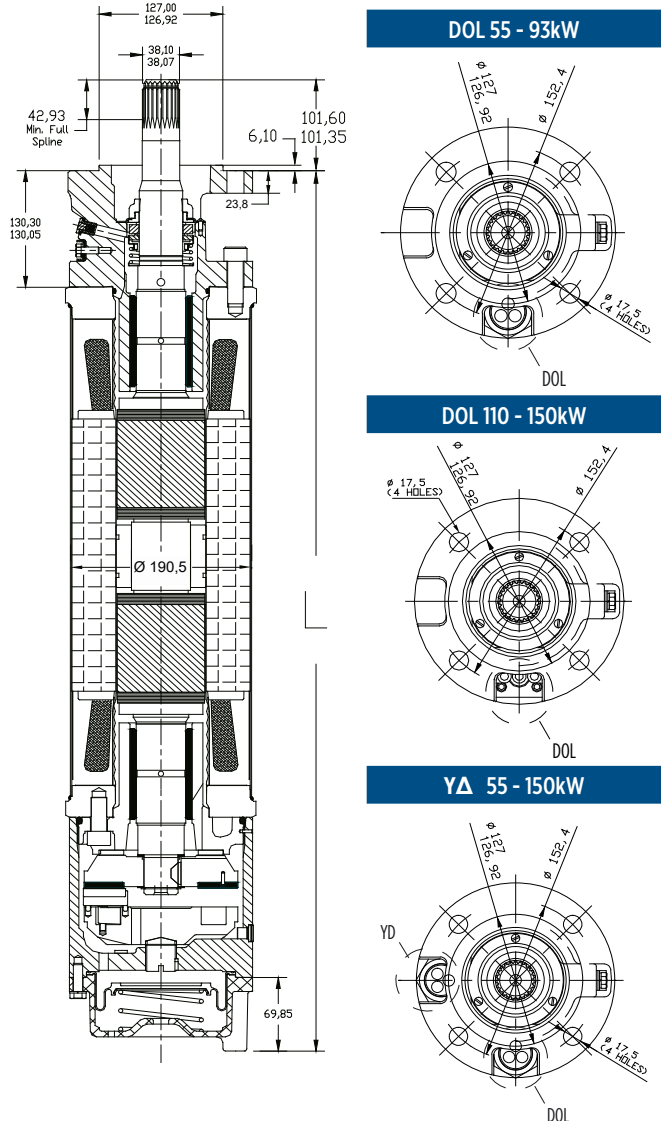

DOL 55 - 93kW

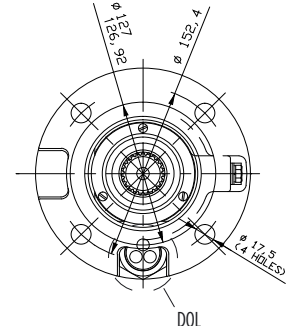

DOL 110 - 150kW

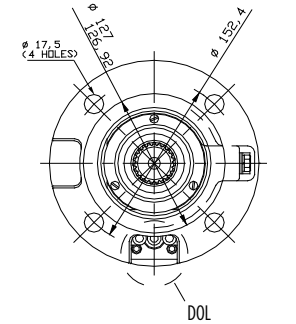

YA 55 - 150kW

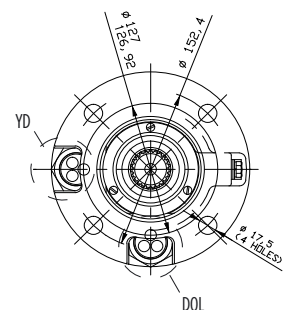

Material DIN / AISI

Parts	WW	316 SS
Shell	1.4301	1.4571
Upper end bell	Cast iron powder coated	1.4408
Lower end bell	Cast iron 20	1.4401
Thrust housing	Cast iron powder coated	1.4408
Mechanical seal	SiC	SiC
Seal cover	1.4301	1.4401
Slinger	BUNA N	Hydrin 100
Shaft end	1.4305	1.4542
Diaphragm	BUNA N	Hydrin
Cable	EPR	EPR
Cap screw (cable)	Brass	1.4401
Lead sleeve	Brass, Ni - plated	1.4401
Lead bushing	Rubber	Rubber
Other seals	BUNA N	BUNA N

Lengths & Weights

P _N [kW]	"L" Dim. [mm]	Shipping Weight [kg]	Shipping Size [mm]
30	925	145	228 x 430 x 1308
37	1000	157	228 x 430 x 1308
45	1077	172	228 x 430 x 1308
55	1264	227	228 x 430 x 1632
75	1455	265	228 x 447 x 1981
93	1748	318	228 x 447 x 1981
110	1976	381	228 x 447 x 2438
130	2179	420	228 x 447 x 2438
150	2408	494	228 x 447 x 2438