

FGR Series - Pumps with grinder unit 50 Hz



FGR SERIES - PUMPS WITH GRINDER UNIT 50 HZ

PUMP IDENTIFICATION CODE

40 | FGR - 5 | 2 - 1,8 | T - G

- “G” (float switch)
- Phase: “M” (Single-phase), “T” (Three-phase)
- Power [kW]
- N. of poles: “2” (2 poles)
- Frequency: “5” (50 Hz), “6” (60 Hz)
- Model: FGR (Franklin Grinder)
- Ø delivery [mm]

00140087 01/2023

40 FGR SERIES 50 HZ

FEATURES & BENEFITS

APPLICATIONS



Pumping of clear non-loaded fluids



Extraction of water from ponds, streams or pits and for rainwater collection



Wastewater



MARKETS

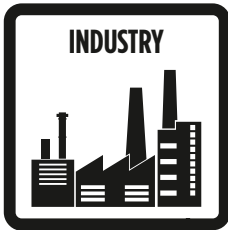

CAST IRON SUBMERSIBLE WASTEWATER LIFT PUMPS WITH GRINDER UNIT

These series of grinder pumps are particularly used in civil and industrial sewage plants. They have been designed to pump the liquid at high head with very low capacity. The cutter unit, in a special hard stainless steel, cuts into small pieces threadlike materials contained in the liquids. As the risk of clogging is avoided small diameter pipes are used. These pumps can be used to lift the sewage of blocks of flats and villas, small isolated areas far from the sewer systems; the sewage of hotels and campsites, in the food and paper industry and in those particular situations where the installation is often expensive by using a gravity system.

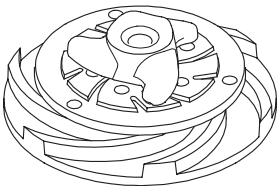

00102587 02/2013

IMPELLER WITH GRINDER UNIT

GENERAL FEATURES

		Materials/Constr.design
Impeller with grinder unit		Cast iron EN GJL200
External casing		Stainless steel AISI304
Pump body		Cast iron EN GJL200
Cover		Cast iron EN GJL200
Grinder unit		Hardened stainless steel
Mechanical seal	motor side	Seal ring
	pump side	Silicon carbide (SiC/SiC)
Motor shaft		Stainless steel AISI416
Power cable	Type	10 m H07RN-F type
	Single-phase	4G1mm ² , capacitor box and SCHUKO plug (CEE 7/VII)
	Three-phase	4G1mm ²
		Motor
Constr.design		asynchronous squirrel cage-type in dry chamber
Type		2 poles; 50 Hz
Insulation class		F
Protection degree		IP68
Voltage	Single-phase	230V ±6% built-in overheating protection, float switch as optional
	Three-phase	230V ±10%, 400V ±10%
		Limits of use
Maximum liquid temperature		+40 °C
pH of pumped liquid		6 - 10
Liquid density		1,0 kg/dm ³
Maximum immersion depth:		5 m
Min. immersion depth for continuous service		303 mm
Max. number of starting/hour		20
		Construction options

- 60 Hz version
- Different voltages
- White oil filling liquid FDA approved

DIMENSIONAL DRAWINGS

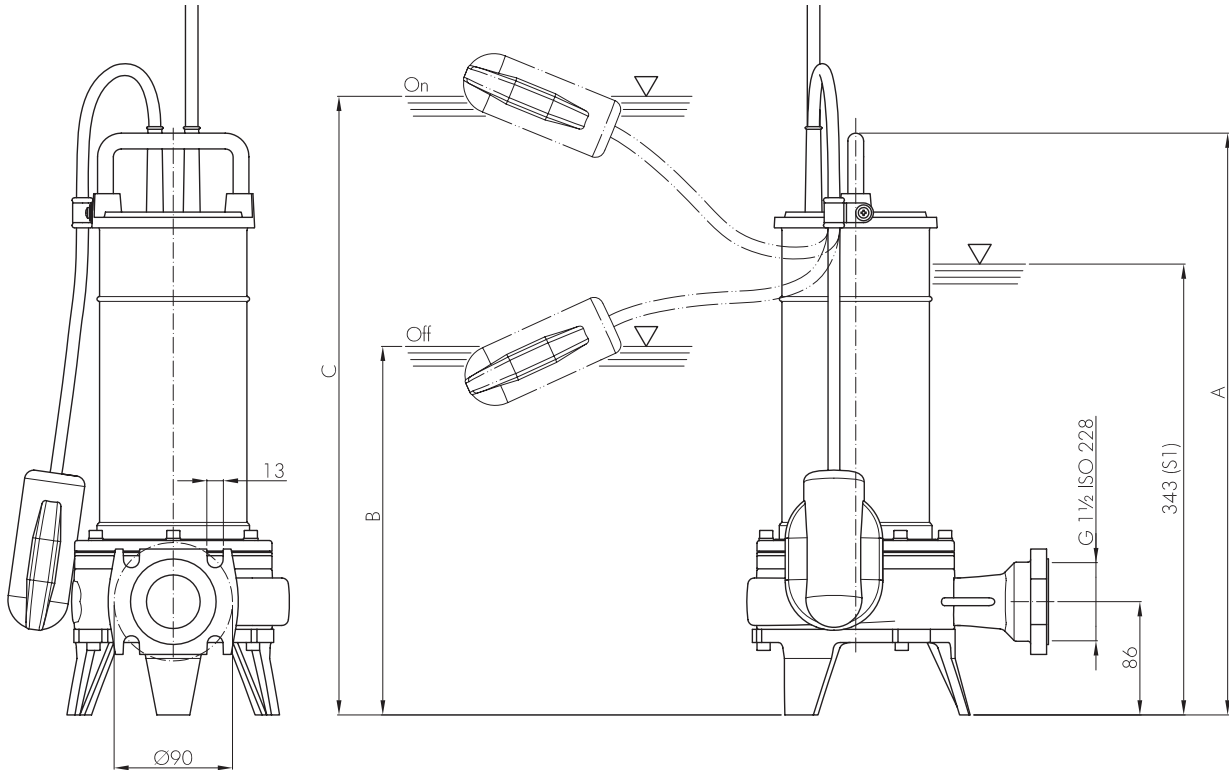

Dimensions [mm]			
Pump model	A	B	C
40FGR-52-0,75	438	280	470
40FGR-52-1,1	463	305	495

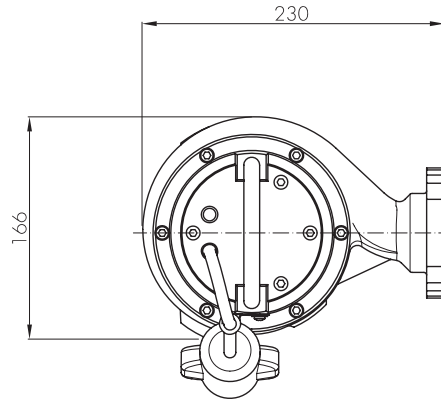

0050291.02/2023

Packaging		
Pump model	Dimensions [mm]	Weight [kg]
40FGR-52-0,75	255x205x560	18,7
40FGR-52-1,1	255x205x560	20,7

Pallet			
Pump model	Dimensions [mm]	N° of pumps	Weight [kg]
40FGR-52-0,75	800x1200x900	32	600
40FGR-52-1,1	800x1200x900	32	670

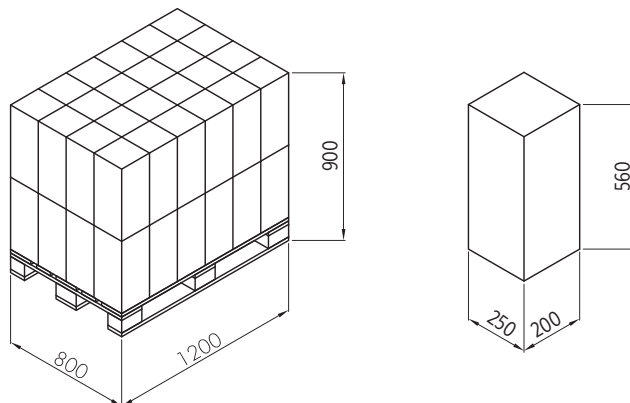

00130292.02/2023

TECHNICAL DATA

Pump model	Motor absorbed power P ₁	Rated power P ₂		Voltage	Rated current	Phase	Power cable		float switch	Running capacitor	Delivery port	Weight [kg]
	[kW]	[kW]	[HP]	[V]	[A]		length [m]	Type		[μf]		
40FGR-52-0,75M	0,9	0,75	1	230	4,8	1 ~	10	4G1	-	20	G1½	18
40FGR-52-0,75M-G	0,9	0,75	1	230	4,8	1 ~	10	4G1	•	20	G1½	18
40FGR-52-0,75T	0,9	0,75	1	400	1,8	3 ~	10	4G1	-	-	G1½	18
40FGR-52-1,1M	1,4	1,1	1,5	230	6	1 ~	10	4G1	-	25	G1½	20
40FGR-52-1,1M-G	1,4	1,1	1,5	230	6	1 ~	10	4G1	•	25	G1½	20
40FGR-52-1,1T	1,4	1,1	1,5	400	2,1	3 ~	10	4G1	-	-	G1½	20

"-" = not available

• = available

HYDRAULIC PERFORMANCE AT 50 HZ

Pump model	Phase	Q = Delivery							
		l/sec 0	0,5	1	1,5	2	2,5	3	3,5
		m ³ /h 0	1,8	3,6	5,4	7,2	9	10,8	12,6
		US gpm 0	7,9	15,8	23,7	31,7	39,6	47,5	55,5
		H = Total meters head of water column [m]							
40FGR-52-0,75	1 ~	18,5	17,4	16,2	14	11,6	8,5	1,3	
	3 ~	18,5	17,4	16,2	14	11,6	8,5	1,3	
40FGR-52-1,1	1 ~	21	19,7	18,5	16,6	14,2	11,2	7,8	1
	3 ~	21	19,7	18,5	16,6	14,2	11,2	7,8	1

PERFORMANCE CURVES AT 50 HZ

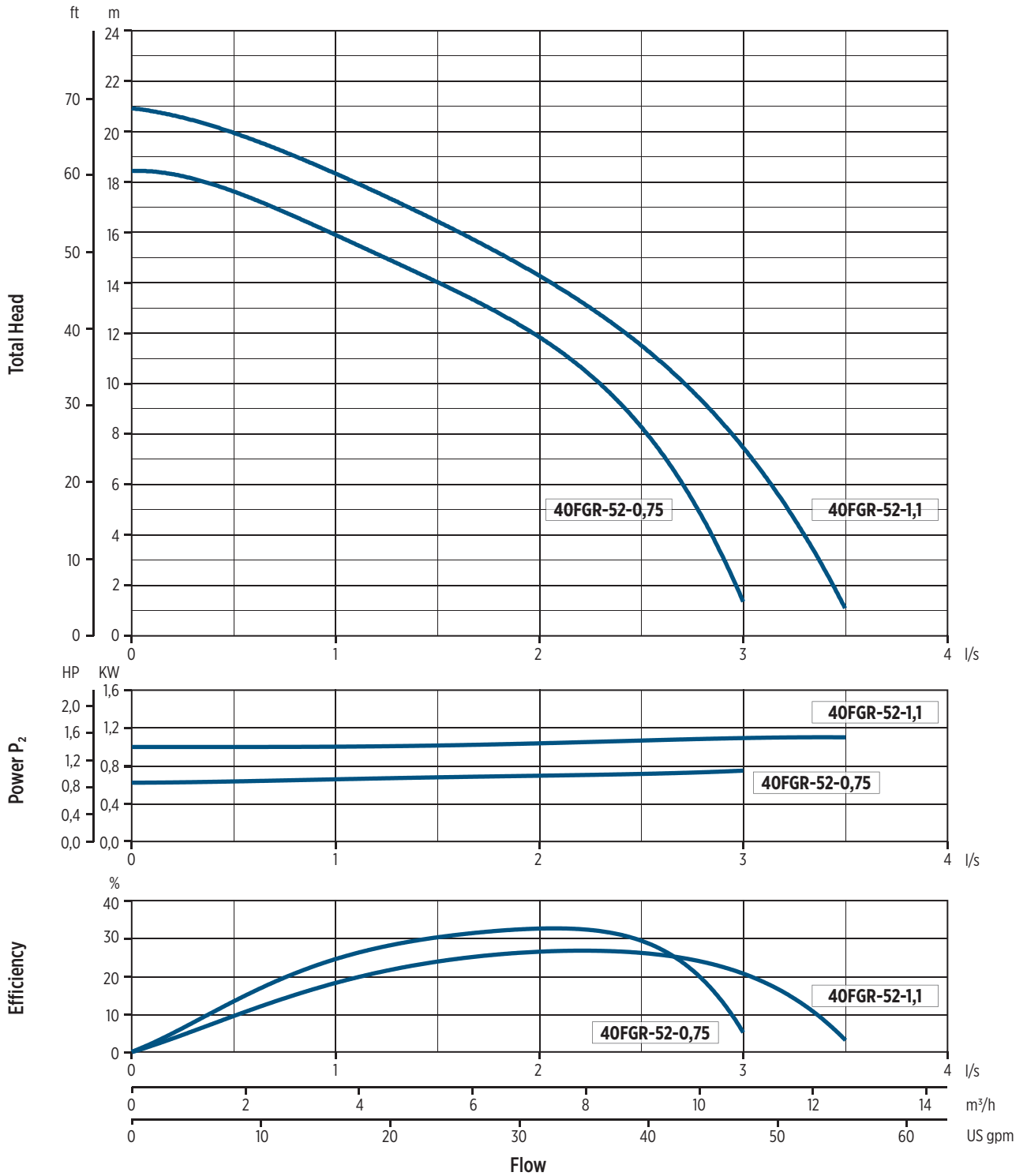

00/2010/05 02/2023

INSTALLATION

INSTALLATION INSTRUCTIONS

PERMANENT INSTALLATION WITH COUPLING SYSTEM

It is the recommended installation for the permanent pumping station. The electric pump is guided by two pipes and it is connected automatically to the coupling system. The quick connection ensures that the pump can be easily removed and re-installed.

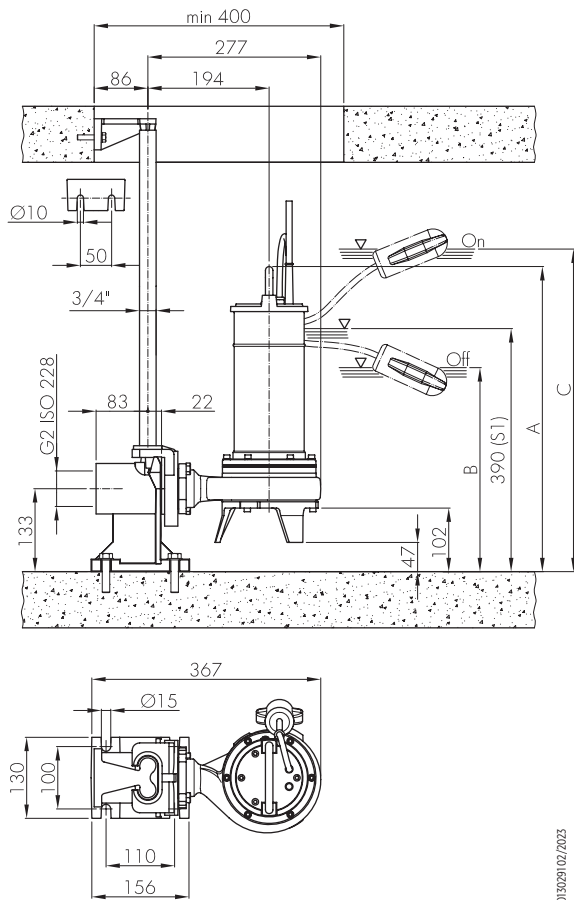

00130291 02/2023

TRANSPORTABLE INSTALLATION

Transportable as emergency pump with connection to the hose and for free installation in the well.

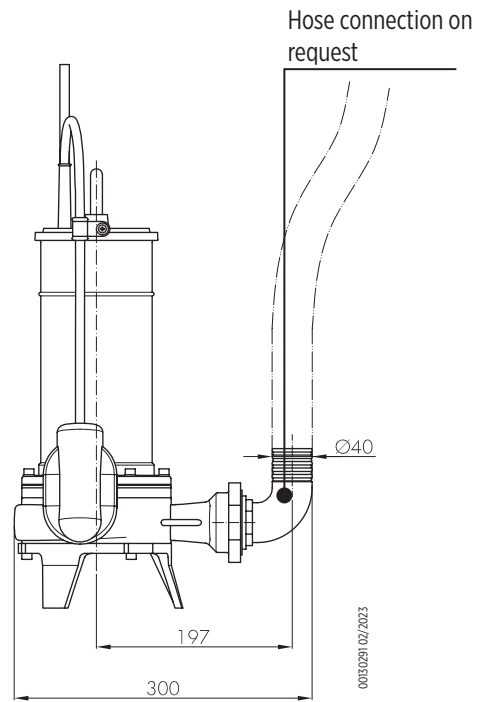

Pump model	Installation Dimensions [mm]		
	A	B	C
40FGR-52-0,75	485	330	515
40FGR-52-1,1	510	355	540

50FGR SERIES 50 HZ

FEATURES & BENEFITS

APPLICATIONS



Pumping of clear non-loaded fluids



Extraction of water from ponds, streams or pits and for rainwater collection



Wastewater



MARKETS

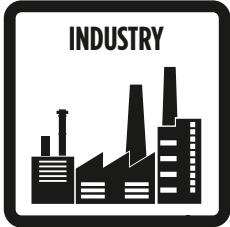

CAST IRON SUBMERSIBLE WASTEWATER LIFT PUMPS WITH GRINDER UNIT

These series of grinder pumps are particularly used in civil and industrial sewage plants. They have been designed to pump the liquid at high head with very low capacity. The cutter unit, in a special hard stainless steel, cuts into small pieces threadlike materials contained in the liquids. As the risk of clogging is avoided small diameter pipes are used. These pumps can be used to lift the sewage of blocks of flats and villas, small isolated areas far from the sewer systems; the sewage of hotels and campsites, in the food and paper industry and in those particular situations where the installation is often expensive by using a gravity system.

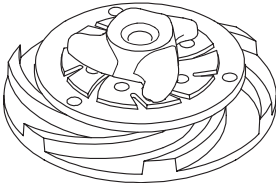

00102587 02/2021

IMPELLER WITH GRINDER UNIT

GENERAL FEATURES

		Materials/Constr.design
Impeller with grinder unit		Cast iron EN GJL200
External casing		Cast iron EN GJL200
Pump body		Cast iron EN GJL200
Cover		Cast iron EN GJL200
Grinder unit		Stainless steel AISI431
Mechanical seal	motor side	Graphite/Alumina
	pump side	Silicon carbide (SiC/SiC)
Motor shaft		Stainless steel AISI431
Power cable	Type	10 m H07RN-F type
	Single-phase	4G1,5mm ² , capacitor box and SCHUKO plug (CEE 7/VII)
	Single-phase 50FGR-52-1,6M	4G2,5mm ² , capacitor box and SCHUKO plug (CEE 7/VII)
	Three-phase	4G1,5mm ²
		Motor
Constr.design		asynchronous squirrel cage-type oil filled
Type		2 poles; 50 Hz
Insulation class		F
Protection degree		IP68
Voltage	Single-phase	230V ±6% built-in overheating protection (up to 1,1 kW), float switch as optional
	Three-phase	230V ±10%, 400V ±10%
		Limits of use
Maximum liquid temperature		+40 °C
pH of pumped liquid		6 - 10
Liquid density		1,0 kg/dm ³
Maximum immersion depth:		5 m
Min. immersion depth for continuous service		
50FGR-52-1,1M/T		373 mm
50FGR-52-1,6M/T / 50FGR-52-2,2T		440 mm
Max. number of starting/hour		20
		Construction options

- 60 Hz version
- Different voltages
- White oil filling liquid FDA approved

DIMENSIONAL DRAWINGS

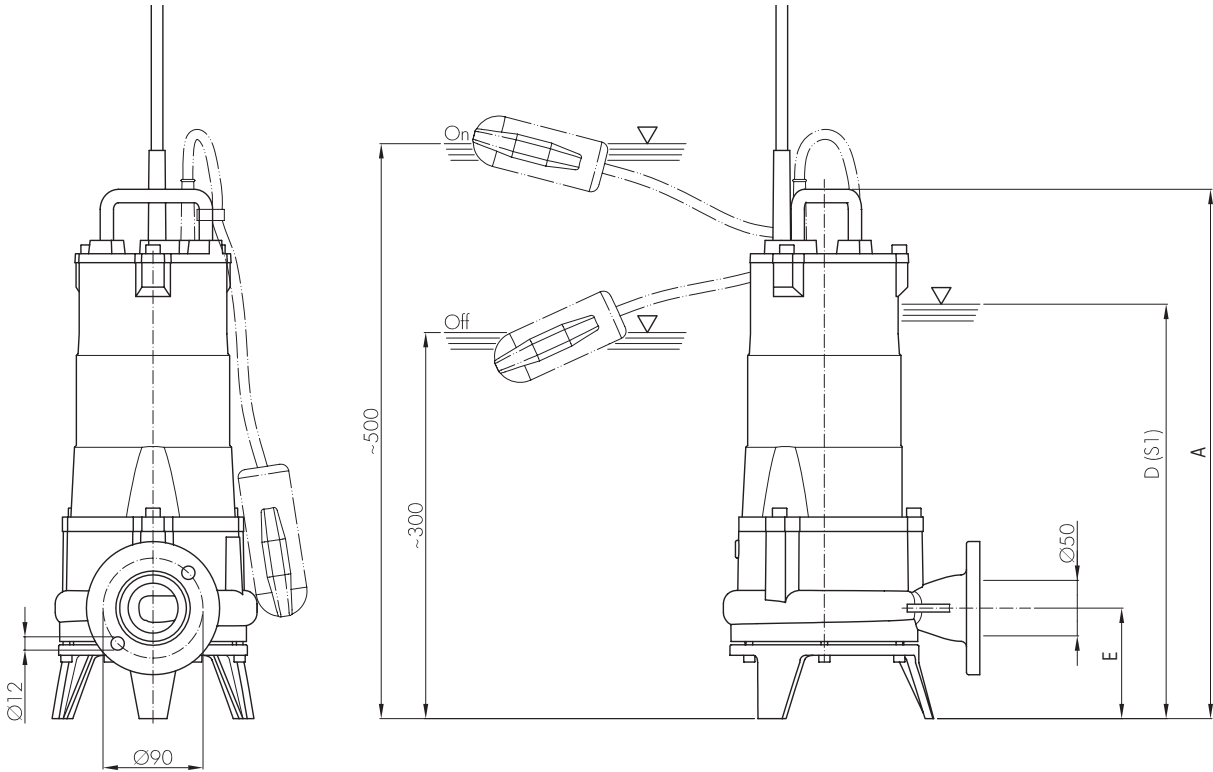

Pump model	Dimensions [mm]				
	A	D	E	F	G
50FGR-52-1,1	477	373	100	185	231
50FGR-52-1,6	550	440	110	220	276
50FGR-52-2,2	550	440	110	220	276

Packaging		
Pump model	Dimensions [mm]	Weight [kg]
50FGR-52-1,1	290x245x585	35
50FGR-52-1,6	300x260x585	41
50FGR-52-2,2	300x260x585	43

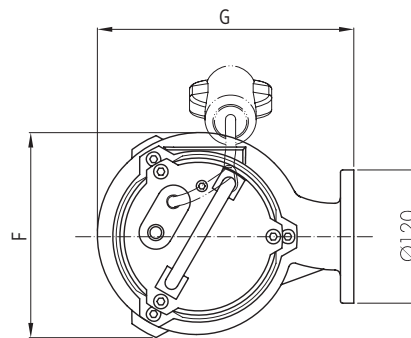

00150294 02/2023

TECHNICAL DATA

Pump model	Motor absorbed power P ₁	Rated power P ₂		Voltage [V]	Rated current [A]	Phase	Power cable		float switch	Running capacitor [μf]	Delivery port	Weight [kg]
	[kW]	[kW]	[HP]				length [m]	Type				
50FGR-52-1,1M	1,4	1,1	1,5	230	7	1 ~	10	4G1,5	-	30	G2 (Ø50)	34
50FGR-52-1,1M-G	1,4	1,1	1,5	230	7	1 ~	10	4G1,5	•	30	G2 (Ø50)	34
50FGR-52-1,1T	2,3	1,6	2,1	230	11	1 ~	10	4G2,5	•	40	G2 (Ø50)	34
50FGR-52-1,1T-G	2,3	1,6	2,1	230	11	1 ~	10	4G2,5	-	40	G2 (Ø50)	34
50FGR-52-1,6M	1,4	1,1	1,5	400	3	3 ~	10	4G1,5	-	-	G2 (Ø50)	40
50FGR-52-1,6M-G	1,4	1,1	1,5	400	3	3 ~	10	4G1,5	•	-	G2 (Ø50)	40
50FGR-52-1,6T	2,3	1,6	2,1	400	4	3 ~	10	4G1,5	-	-	G2 (Ø50)	40
50FGR-52-1,6T-G	2,3	1,6	2,1	400	4	3 ~	10	4G1,5	•	-	G2 (Ø50)	40
50FGR-52-2,2T	3,1	2,2	3	400	5	3 ~	10	4G1,5	-	-	G2 (Ø50)	42

"-" = not available

• = available

HYDRAULIC PERFORMANCE AT 50 HZ

Pump model	Phase	Q = Delivery										
		l/sec 0	0,5	1	1,5	2	2,5	3	3,5	4	4,5	5
		m ³ /h 0	1,8	3,6	5,4	7,2	9	10,8	12,6	14,4	16,2	18
		US gpm 0	7,9	15,8	23,7	31,7	39,6	47,5	55,5	63,4	71,3	79,2
H = Total meters head of water column [m]												
50FGR-52-1,1	1 ~	21	19	17	15,8	14	12	9,5	8,8	7,8	5,8	2
	3 ~	21	19	17	15,8	14	12	9,5	8,8	7,8	5,8	2
50FGR-52-1,6	1 ~	27	25	21	20,5	19	18	15,5	14,5	13	10	5
	3 ~	27	25	21	20,5	19	18	15,5	14,5	13	10	5
50FGR-52-2,2	3 ~	34	32	29,5	27,5	25,7	23,8	22	20	17,5	15	10

PERFORMANCE CURVES AT 50 HZ

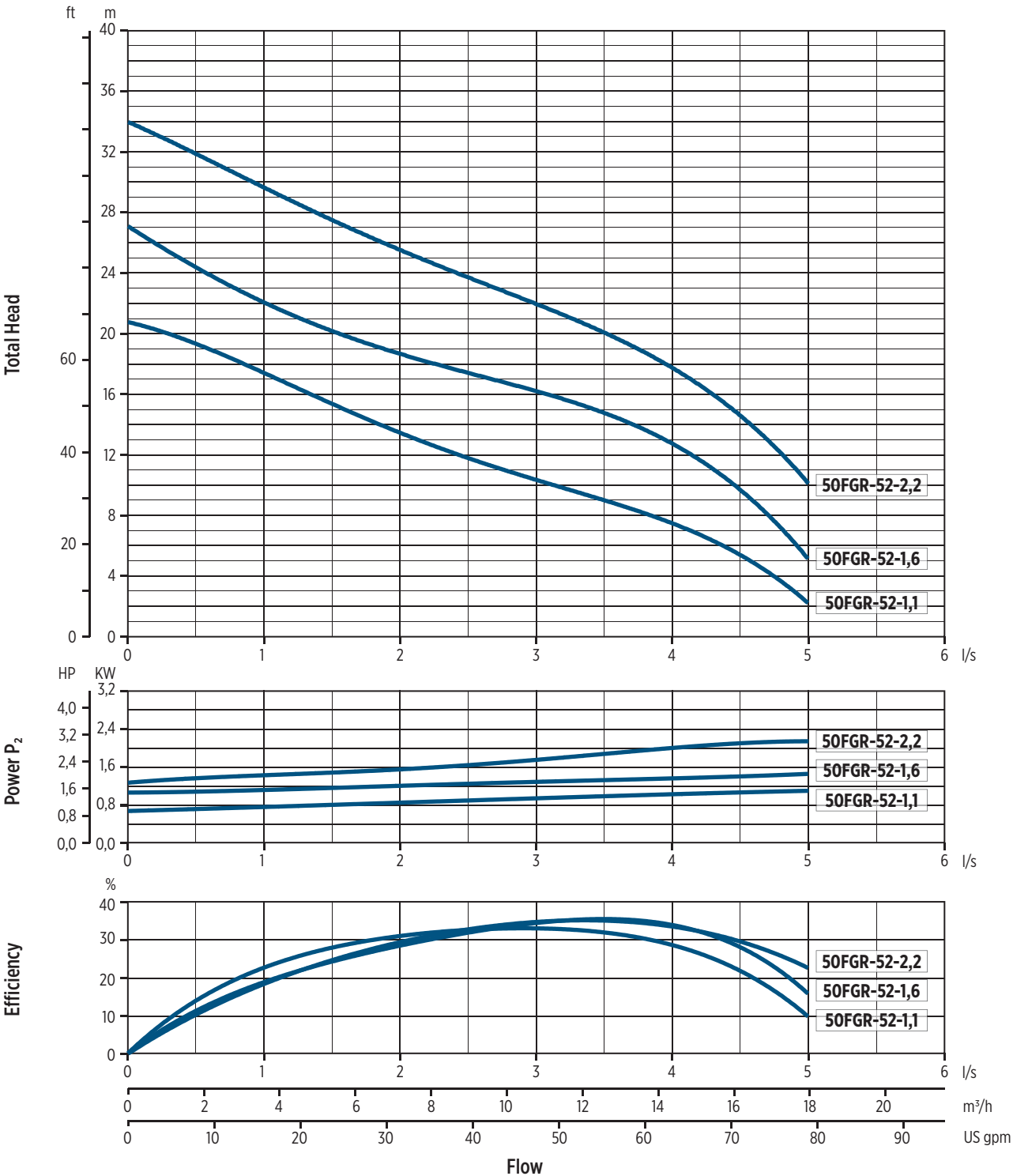

00201014_02/2023

INSTALLATION

INSTALLATION INSTRUCTIONS

PERMANENT INSTALLATION WITH COUPLING SYSTEM

It is the recommended installation for the permanent pumping station. The electric pump is guided by two pipes and it is connected automatically to the coupling system. The quick connection ensures that the pump can be easily removed and re-installed.

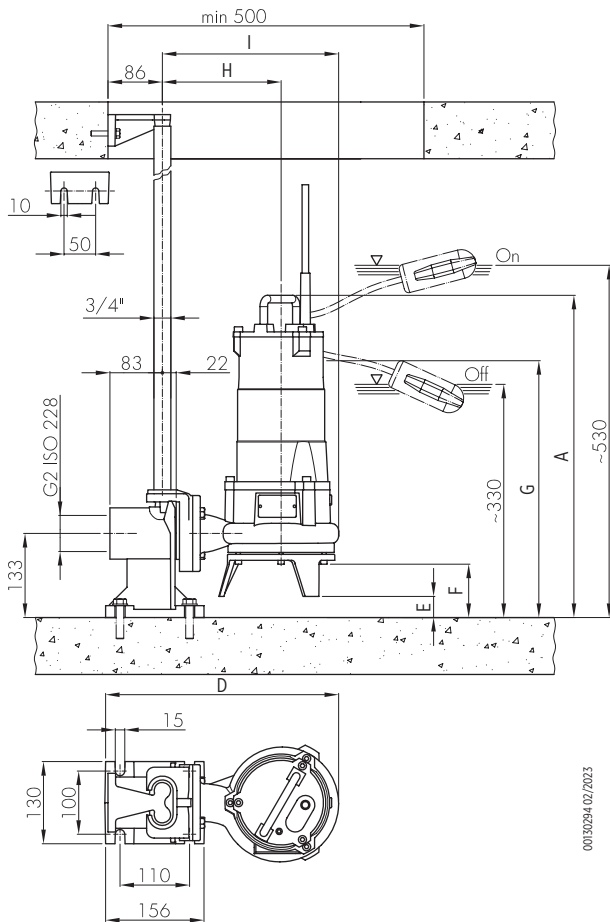

TRANSPORTABLE INSTALLATION

Transportable as emergency pump with connection to the hose and for free installation in the well.

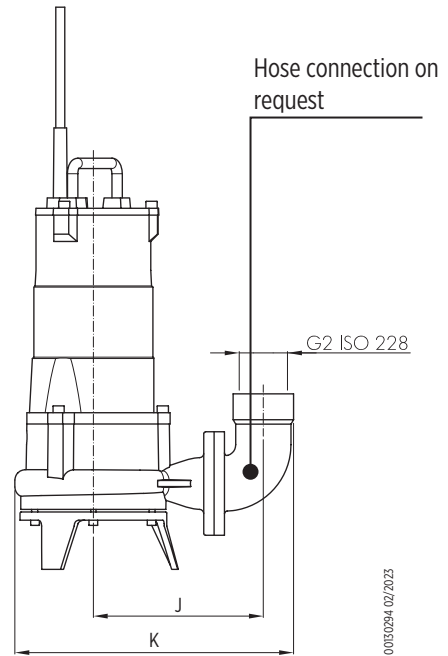

Pump model	Installation Dimensions [mm]								
	A	D	E	F	G	H	I	J	K
50FGR-52-1,1	510	370	34	85	407	193	279	197	232
50FGR-52-1,6	574	414	24	76	464	215	324	224	368
50FGR-52-2,2	574	414	24	76	464	215	324	224	368