

6" 3~ ENCAPSULATED PERMANENT MAGNET MOTOR

BENEFITS & FEATURES

- Double-flange NEMA mounting design
- Stainless steel splined shaft
- StatorShield™ - Franklin encapsulation system
- Factory filled with Franklin's non-toxic water soluble fill solution
- High capacity Kingsbury type liquid lubricated thrust bearing for 100 % maintenance free operation
- Field replaceable lead using Franklin's exclusive Water Bloc technology
- Pressure-equalizing diaphragm, spring pre-loaded
- SandFighter™ sealing system with SIC mechanical seal and sand slinger
- High efficiency electrical design for low operation costs
- All motors manufactured in ISO 9001 certified plants and 100% tested
- Drinking water approvals



STANDARD SPECIFICATION

- Ratings: 4 - 45 kW (100 Hz - 3000 rpm)
- Thrust load: 15.5 kN: 4 - 22 kW, 27.5 kN: 26 - 45 kW
- System Supply Voltage: 380 V (100 Hz)
- DOL- start
- Voltage Tolerance: $\pm 10\% U_N$
- Nominal ambient temperature: 30 °C
4 - 22 kW: with 0.16 m/s cooling flow; > 22 kW: with 0.5 m/s cooling flow
- Protection IP68 and insulation class F
- Standard Motor: WW- Water well Design (Stator 304SS / Castings - CI Powder coated)
- Frequency of starts: 20 starts/hour (with min. 3 minutes resting time), equally distributed
- Motors installation orientation: Vertical / horizontal (shaft end heightened)
- Rotation counter clock wise facing shaft end (Rotation reversible)
- All motors with factory installed leads

OPTIONS



- Higher-graded materials: 304SS, 316SS
- Retrofittable PT 100 temperature sensor (VFD PT100 Plug-in card necessary, order no. 308 170 202)
- Special lead lengths
- High Thrust design 45 kN
- 120 Hz electrical design



3~ DOL MODEL NUMBERS 380 V / 100 HZ

P _N [kW]	U _N [V]	Thrust F [N]	Digit 1 - 6	Digit 7 - 10		
				WW**	304SS	Standard 316SS
				Single pack with pre-installed lead*	Single pack with pre-installed lead*	Single pack with pre-installed lead*
4 - 11	380	15.500	236 080	9561	1461	1561
13 - 22	380	15.500	236 084	9561	1461	1561
26 - 45	380	27.500	236 086	9561	1461	1561

* with 4 m motor short lead

** WW (Water well)- Stator 304SS / Castings - CI Powder coated

6" 3~ ENCAPSULATED PERMANENT MAGNET MOTOR

EFFICIENCY CURVE AT 3000 RPM

efficiency [%] Motor η 380 V / 100 Hz [%] = f (P2 [kW])

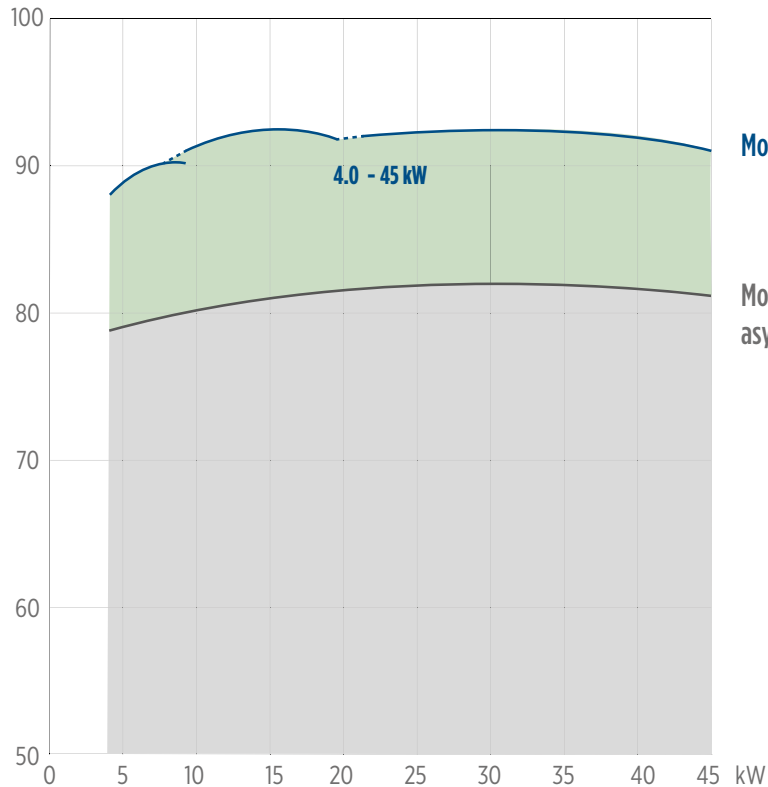

Motor efficiency of synchronous motors

Motor efficiency of equivalent asynchronous motors

3~ MOTOR PERFORMANCE DATA 380 V / 100 HZ

motor model no.	P_N [kW]	Thrust F [N]	U_N [V]	n [min ⁻¹]	I_N [A]	I_A/I_N	η [%]	cos phi	T_N [Nm]	T_A/T_N
236 080 xxxx	4	15500	380	3000	9.2	1	87.1	0.95	12.7	1
	5.5				11.0	1	89.8	0.95	17.5	1
	7.5				14.1	1	90.9	0.95	23.9	1
236 080 xxxx	9.3	15500	380	3000	17.2	1	91.2	0.95	29.6	1
	11				20.5	1	90.9	0.95	35.0	1
236 084 xxxx	13	15500	380	3000	25.3	1	91.4	0.95	41.4	1
	15				28.3	1	91.8	0.95	47.7	1
236 084 xxxx	18.5	15500	380	3000	34.1	1	92.1	0.95	58.9	1
236 084 xxxx	22	15500	380	3000	40.7	1	92.0	0.95	70.0	1
236 086 xxxx	26	27500	380	3000	51.2	1	92.3	0.95	82.8	1
	30				57.8	1	92.5	0.95	95.5	1
236 086 xxxx	37	27500	380	3000	71.3	1	92.1	0.95	117.8	1
236 086 xxxx	45	27500	380	3000	90.0	1	90.8	0.95	143.2	1

6" 3~ ENCAPSULATED PERMANENT MAGNET MOTOR

ELECTRICAL CONNECTION AND MOTOR LEADS 3~ DOL

4G4 mm ²	3 x 8.4 + 1G 8.4 mm ²	Electrical connection								
		<table border="1"> <thead> <tr> <th>U</th> <th>V</th> <th>W</th> <th>PE</th> </tr> </thead> <tbody> <tr> <td>brown</td> <td>grey</td> <td>black</td> <td>yellow/green</td> </tr> </tbody> </table>	U	V	W	PE	brown	grey	black	yellow/green
U	V	W	PE							
brown	grey	black	yellow/green							

Motor lead*							
4 - 22 kW							
∅ [mm ²]	C [mm]	B [mm]	H [mm]	L [m]	WW	316SS	
4G4	32	19	7	4	310 125 004	310 125 504	
26 - 45 kW							
∅ [mm ²]	C [mm]	B [mm]	B1 [mm]	B1 [mm]	H [mm]	WW	316SS
3x8.4+1G8.4	32	29.5	19.5	19.5	8.9	310 145 004	310 145 504

*Cables are designed for submerged operation. For air operation, please consult Franklin Electric.

WINDING RESISTANCE 380 V / 100 HZ

P _N [kW]	U _N [V]	Stator Ref.	U - V [Ohm]*	Rotor Ref.
4 - 11	380	327 245 ...	0.86	178 130 921
13 - 22	380	327 250 ...	0.33	178 130 923
26 - 45	380	327 257 ...	0.19	178 130 925

6" 3~ ENCAPSULATED PERMANENT MAGNET MOTOR

MOTOR DIMENSIONS AND MATERIALS

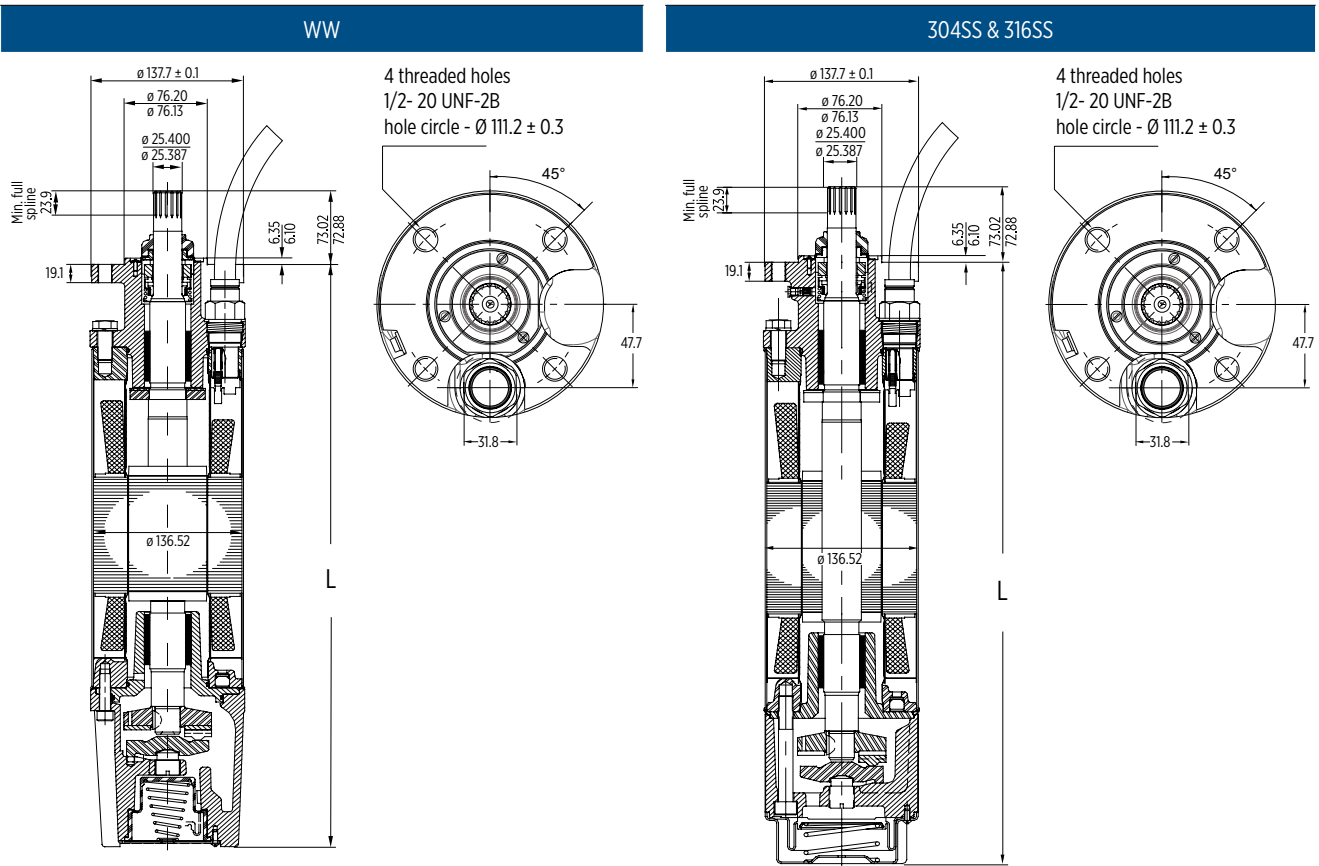

MOTOR DIMENSIONS

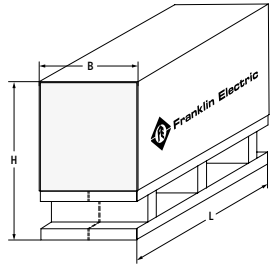
P _N [kW]	U _N [V]	Thrust F [N]	WW	304SS/316SS	M [kg]	Motor with lead in single pack		Motor packing
			L [mm]	L [mm]		B x H x L [mm]	[kg]	
4 - 11	380	15.500	634,5	625,2	43,0	155 x 340 x 800	45	
13 - 22	380	15.500	793,5	784,2	57,4	155 x 340 x 1070	61	
26 - 45	380	27.500	1020,5	1011,2	78,0	155 x 340 x 1070	84	

Tolerances according to NEMA MG 1-18.388

MOTOR MATERIAL DESCRIPTION

Part	WW	304SS	316SS
Shell	1.4301	1.4301	1.4571
Upper end bell	Cast iron powder coated	1.4301	1.4408
Thrust housing	Cast iron powder coated	1.4301	1.4408
Mechanical seal	SiC / SiC	SiC / SiC	SiC / SiC
Seal cover	1.4301	1.4301	1.4401
Slinger	EPDM	EPDM	EPDM
Shaft end*	1.4021	1.4021	1.4462
Diaphragm	EPDM	EPDM	EPDM
Lead	EPR	EPR	EPR

* running change to 1.4462 (WIP)

6" 3~ ENCAPSULATED PM MOTOR SPARE PARTS WW

MOTOR PARTS DESCRIPTION

Kit	part description	incl. positions	order no.
Kit A2 15.500N	Thrust bearing kit up to 22 kW	26	308 750 120
Kit A3 27.500N	Thrust bearing kit 26 - 45 kW	26	308 750 120
Kit B1	Seal kit	4, 17, 20, 41, 42	308 800 125
Kit C1	Slinger kit	1, 2, 3, 37	308 725 101
Kit D1	Screw kit	5, 19, 24	308 659 121
Kit E1*	Radial bearing kit up to 22 kW	12	308 678 103
Kit E2	Radial bearing kit 26 - 45 kW	12	308 678 110
PT100 Kit		44	see page 305

* Kit without rotor shaft sleeves, flange replacement bushings are unfinished

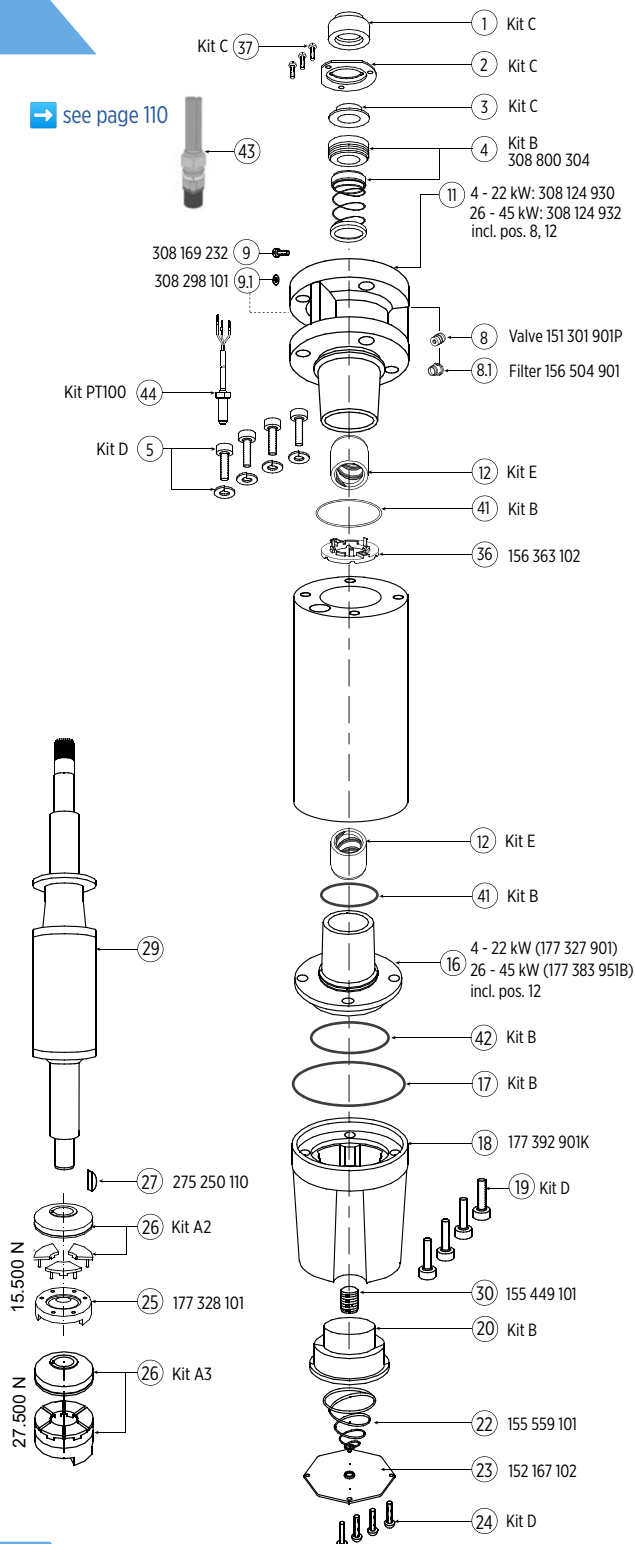

SPARE PARTS STATOR AND ROTOR WW 380 V / 100 HZ

P_N [kW]	U_N [V]	Thrust F [N]	Motor Model No.	Stator Model No.	Rotor
4 - 11	380	15.500	236 080 9561	327 245 963K	178 130 901K
13 - 22	380	15.500	236 084 9561	327 250 963K	178 130 903K
26 - 45	380	27.500	236 086 9561	327 257 963K	178 130 905K

6" 3~ ENCAPSULATED PM MOTOR SPARE PARTS 304SS / 316SS

MOTOR PARTS DESCRIPTION

Kit	part description	incl. positions	order no.
Kit A2	Thrust bearing kit 15.500 N	26	308 750 120
Kit A3	Thrust bearing kit 27.500 N	26	308 750 200
Kit B3	Seal kit	4, 17, 20, 21, 41, 44	308 800 250
Kit C3	Slinger kit	1, 2, 3, 37	308 725 150
Kit D5	Screw kit	5, 19, 24	308 659 155
Kit E1*	Radial bearing kit up to 22 kW	12	308 678 103
Kit E2	Radial bearing kit 26 - 45 kW	12	308 678 110
PT100 Kit		44	see page 305

* Kit without rotor shaft sleeves, flange replacement bushings are unfinished

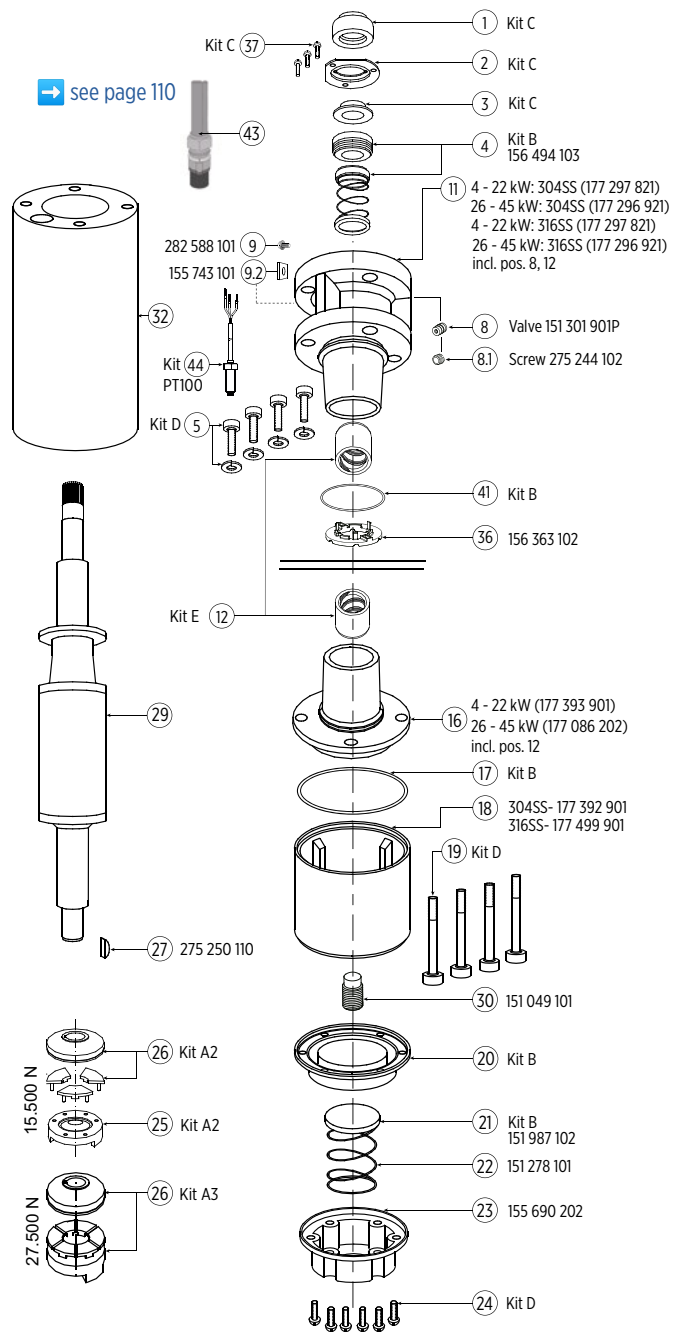

SPARE PARTS STATOR AND ROTOR 304 / 316SS 380 V / 100 HZ

P _N [kW]	U _N [V]	Thrust F [N]	Motor Model No.		Stator Model No.	Rotor
			304SS	316SS		
4 - 11	380	15.500	236 080 1461	236 080 1561	327 245 983K	178 130 921K
13 - 22	380	15.500	236 084 1461	236 084 1561	327 250 983K	178 130 923K
26 - 45	380	27.500	236 086 1461	236 086 1561	327 257 983K	178 130 925K