

Kiekis	Aprašymas
--------	-----------

1	MAGNA3 40-180 F N
---	-------------------



Atkreipkite dėmesį! Paveikslėlyje parodytas produktas gali skirtis nuo tikrojo

Produkto Nr.: [97924353](#)

The Grundfos MAGNA3 circulator pump is the ideal choice for almost any building project – old or new. With its unrivalled energy efficiency, all-encompassing range and built-in communication capabilities, MAGNA3 is ideal for engineers and specifiers looking to create high-performance heating and cooling systems.

The pump is maintenance-free due to the canned-rotor type design. This also means that pump and motor form an integral unit without shaft seal and with only two gaskets for sealing. The bearings are lubricated by the pumped liquid.

MAGNA3 features an intuitive display and allows you to connect wirelessly with the Grundfos GO Remote app, giving you access to advanced reporting and monitoring.

MAGNA3 model E has Bluetooth, which allows you to connect directly to Grundfos Go app on your smart phone without any need for a dongle.

The pump includes fieldbus communication via CIM modules as well as analog and digital inputs and configurable relays.

Control features include AUTOADAPT and FLOWADAPT. FLOWADAPT which reduces the need for throttling valves, thus cutting costs on system components.

MAGNA3 is the superior choice for a wide range of heating and cooling applications, including:

- Mixing loops
- Heating surfaces
- Air conditioning surfaces
- Ground-source heat pump systems
- Smaller chiller applications.

MAGNA3 is a single-phase pump and characterised by having the controller and control display integrated in the control box. The pump also has a built-in differential-pressure and temperature sensor.

The pump housing is available in both cast-iron and stainless-steel versions. The composite rotor can be carbon-fibre reinforced, the bearing plate and rotor cladding are made of stainless steel and the stator housing is made of aluminium. The power electronics are air-cooled.

MAGNA3 incorporates a 4-pole synchronous, permanent-magnet motor (PM motor). This motor type is characterised by higher efficiency than a conventional asynchronous squirrel-cage motor. The pump speed is controlled by an integrated frequency converter.

## 97924353 MAGNA3 40-180 F N

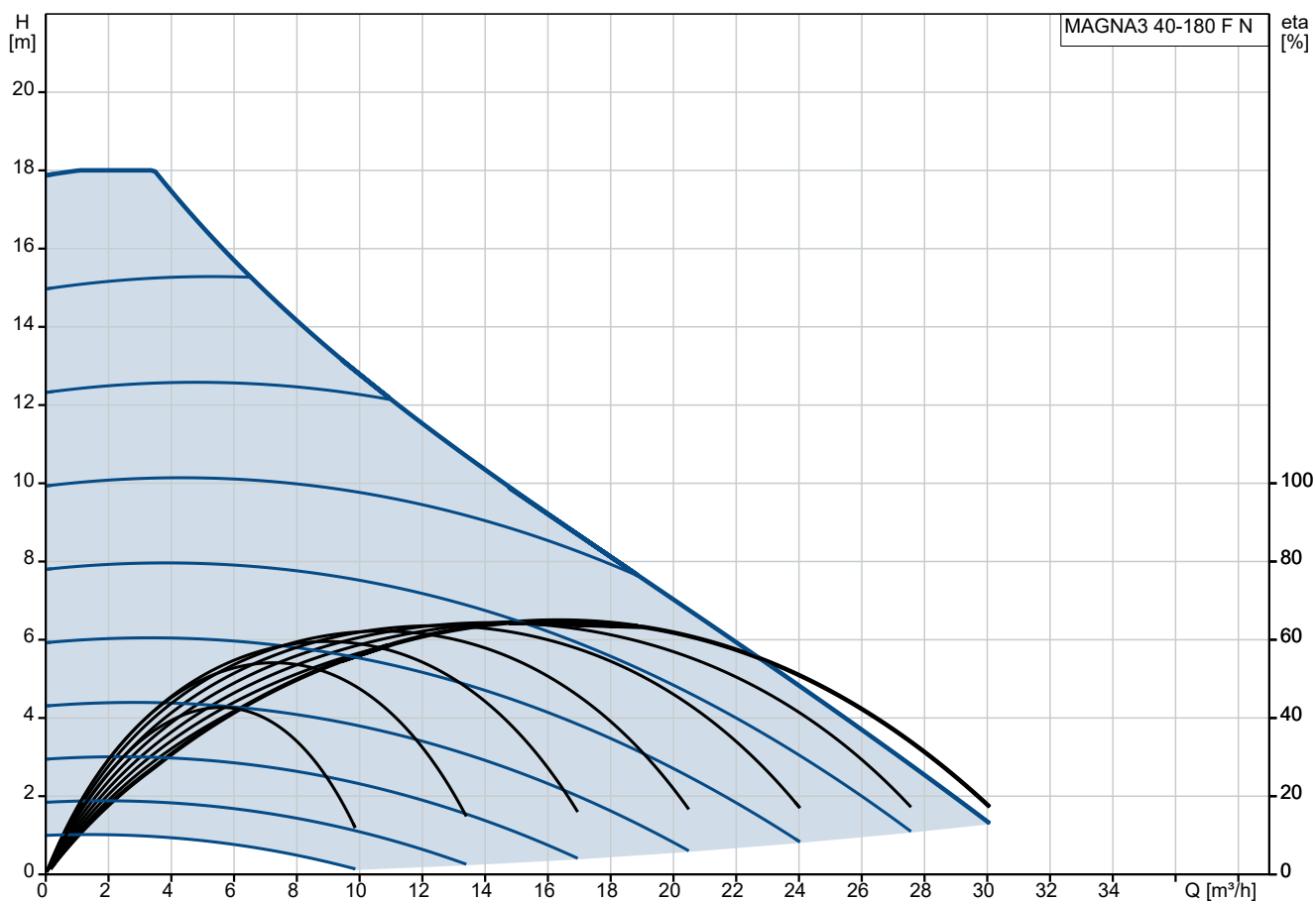

Siurbiamas skystis = Vanduo  
 Skysčio temperatūra darbo metu = 60 °C  
 Tankis = 983.2 kg/m³

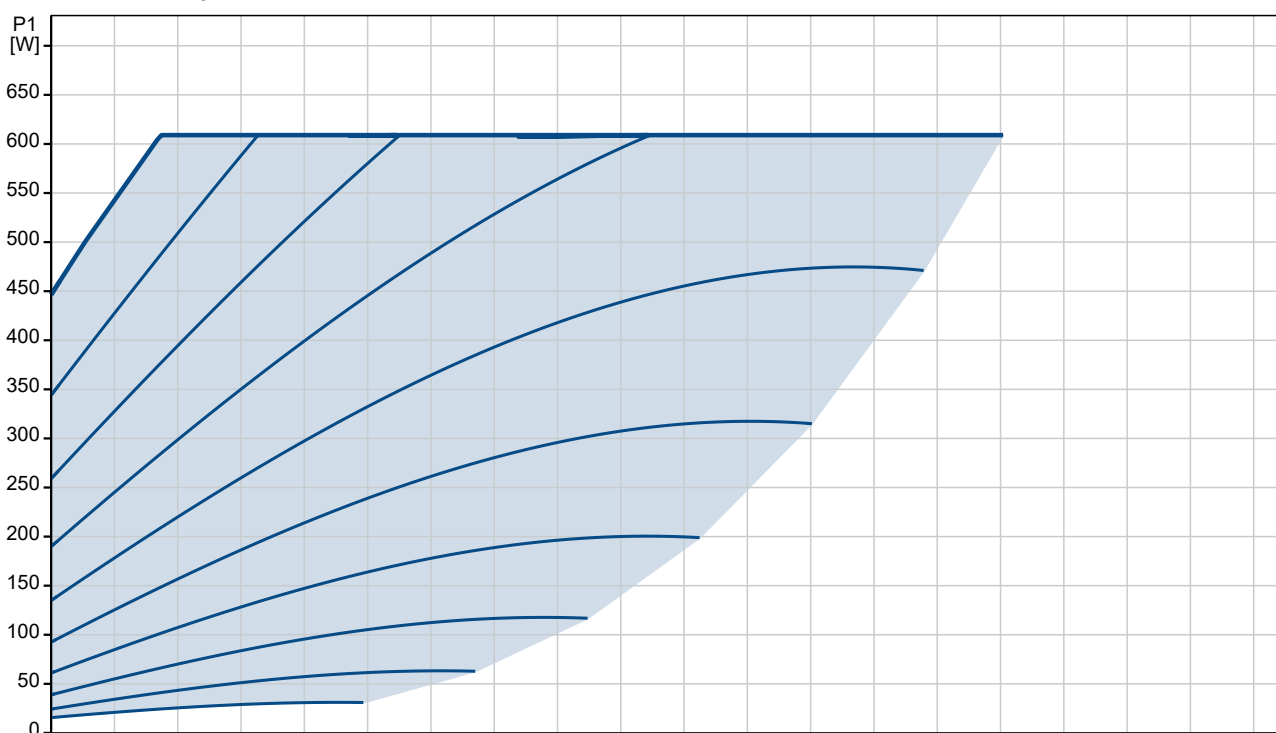

Aprašymas	Vertė
<b>Bendra informacija:</b>	
Produkto pavadinimas:	MAGNA3 40-180 F N
Produkto Nr.:	97924353
EAN numeris:	5710626494293
<b>Techniniai duomenys:</b>	
Nominalus debitas:	16.04 m³/h
Nominalus slėgio aukštis:	9.2 m
Maks. slėgio aukštis:	180 dm
TF klasė:	110
Approvals:	CE, VDE, EAC, MOROCCO, UKCA, TSERCM, UkrSEPRO
Tinkamumo geriamajam vandeniui sertifikatai:	WRAS, ACS, UBA
Modelis:	E
<b>Medžiagos:</b>	
Siurblio korpusas:	Nerūdijantis plienas
Siurblio korpusas:	EN 1.4308
Siurblio korpusas:	ASTM 351 CF8
Darbaratis:	PES 30%GF
<b>Įrengimas:</b>	
Aplinkos temperatūros intervalas:	0 .. 40 °C
Maksimalus darbinis slėgis:	10 bar
Standartinis flanšas:	DIN
Vamzdžio jungtis:	DN 40
Slėgis:	PN 6/10
Montažinis ilgis:	250 mm
<b>Skystis:</b>	
Siurbiamas skystis:	Vanduo
Skysčio temperatūros diapazonas:	-10 .. 110 °C
Skysčio temperatūra eksploataavimo metu:	60 °C
Tankis:	983.2 kg/m³
<b>Elektrotechniniai duomenys:</b>	
Naudojama galia P1:	16 .. 609 W
Elektros tinklo dažnis:	50 / 60 Hz
Nominali įtampa:	1 x 230 V
Maksimali vartojama srovė:	0.18 .. 2.78 A
Korpuso klasė (IEC 34-5):	X4D
Izoliacijos klasė (IEC 85):	F
<b>Kita:</b>	
Energija (EEI):	0.17
Neto masė:	16.7 kg
Bendra masė:	18.2 kg
Tiekimo tūris:	0.039 m³
Danijos VVS Nr.:	380982418
Švedijos RSK Nr.:	5803220
Norvegijos NRF Nr.:	9042738
Kilmės šalis:	DE
Muitinės kodas:	84137030
Environmental approvals:	CN ROHS, WEEE

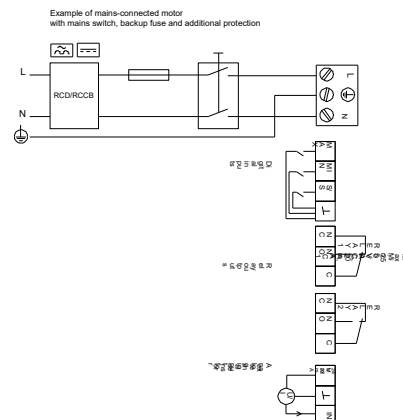
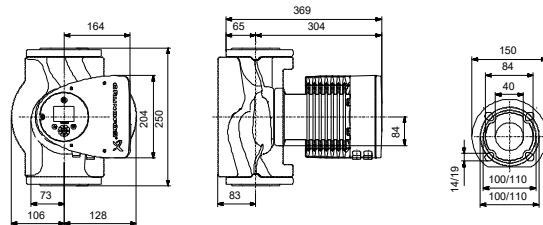
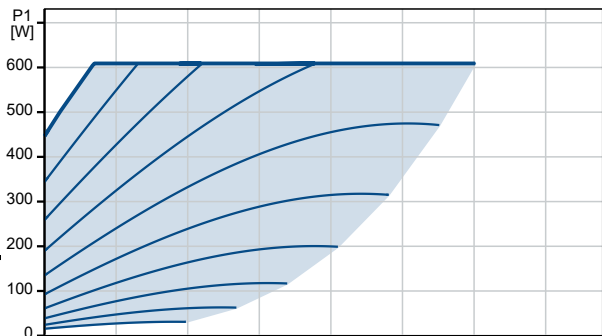
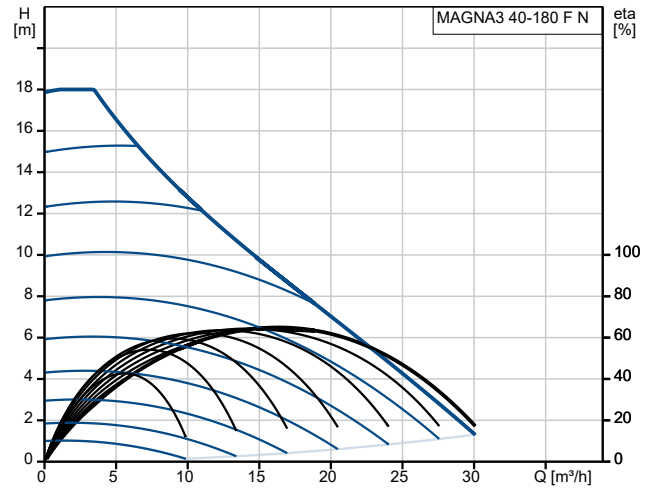

## 97924353 MAGNA3 40-180 F N

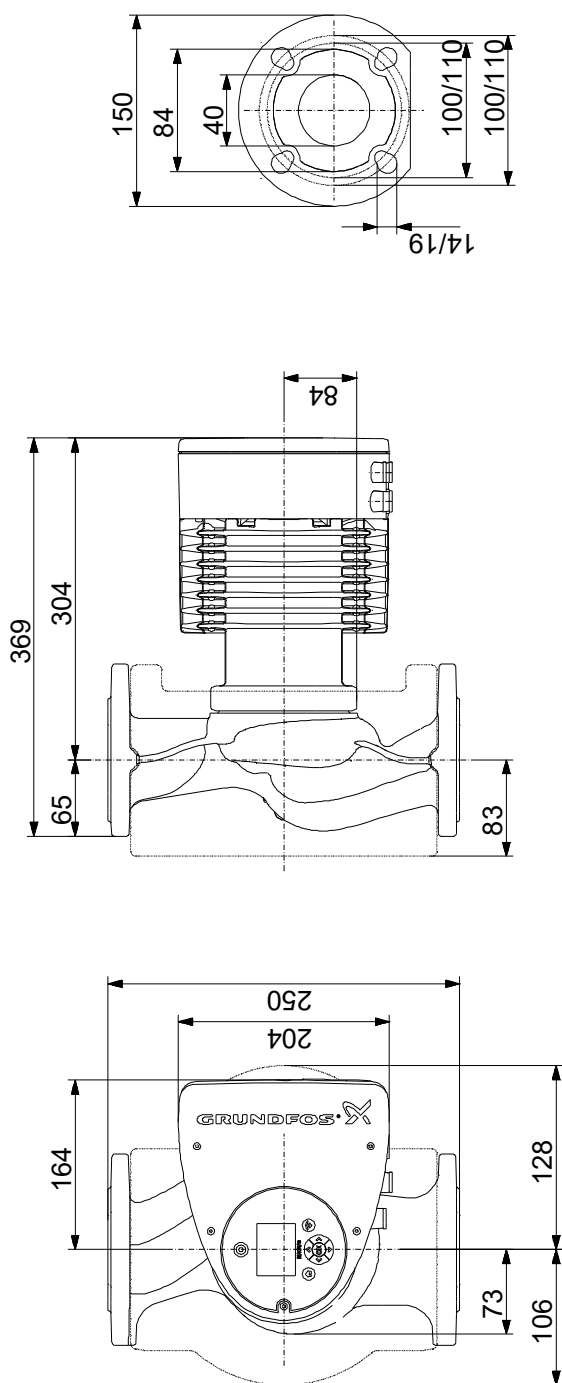

Atkreipkite dėmesį! Visi matmenys, jei nenurodyta kitaip, pateikti milimetrais.

Atsakomybės apribojimas: šiame supaprastintame matmenų brėžinyje neparodytos visos detalės.

## 97924353 MAGNA3 40-180 F N

Example of mains-connected motor with mains switch, backup fuse and additional protection

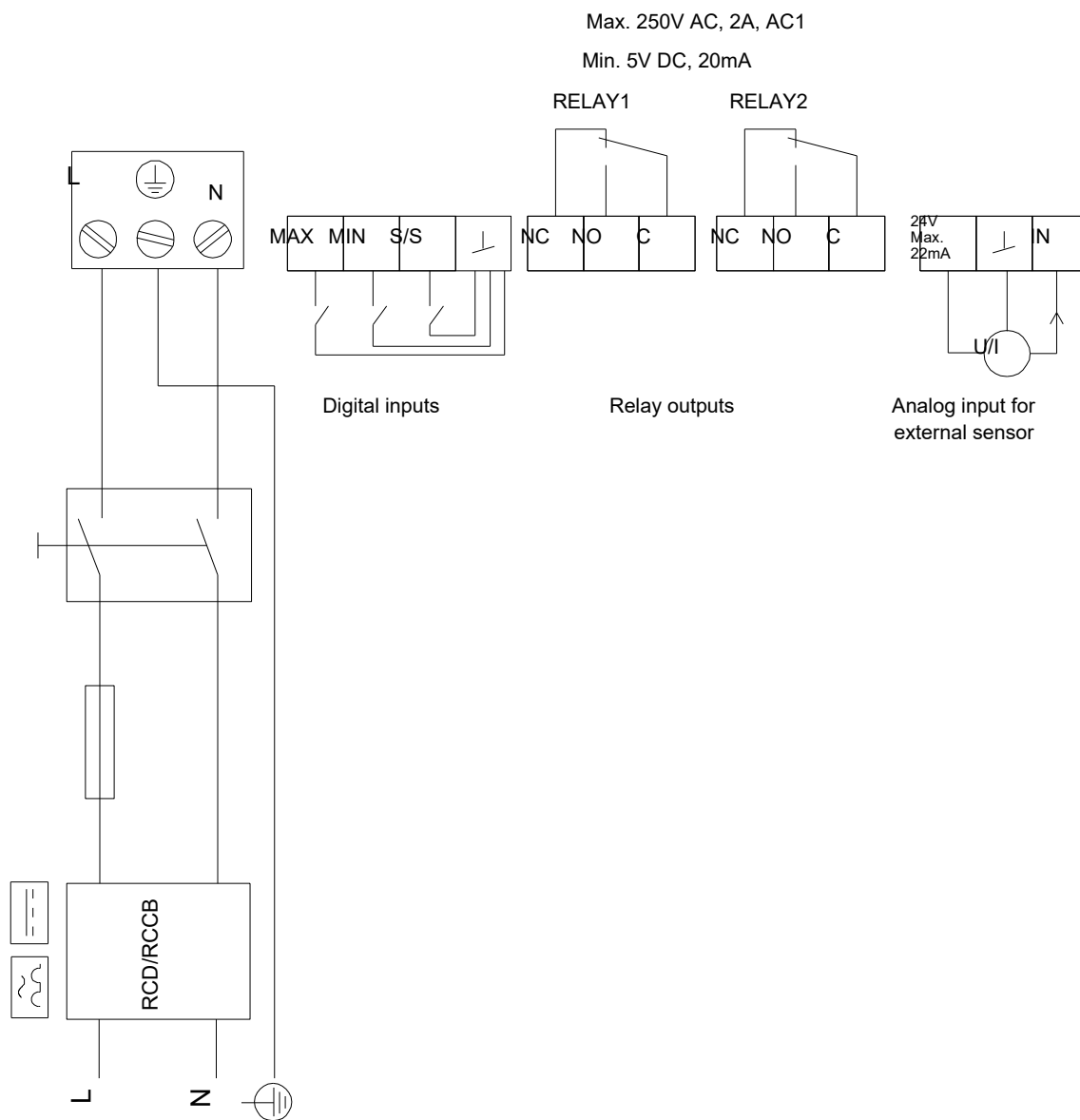

Atkreipkite dėmesį! Visi matmenys, jei nenurodyta kitaip, pateikti milimetrais.