

MULTI STAGE

ENGLISH



Index

Immersion type multistage centrifugal pumps 50Hz datasheets.....	
MI 01 pumps datasheet.....	08
MI 02 pumps datasheet.....	10
MI 03 pumps datasheet.....	12
MI 04 pumps datasheet.....	14
MI 08 pumps datasheet.....	16
MI 16 pumps datasheet.....	18
MI 20 pumps datasheet.....	20
MI 32 pumps datasheet.....	22
MI 42 pumps datasheet.....	24
Immersion type multistage centrifugal pumps 60Hz datasheets.....	
MI 01 pumps datasheet.....	32
MI 02 pumps datasheet.....	34
MI 03 pumps datasheet.....	36
MI 04 pumps datasheet.....	38
MI 08 pumps datasheet.....	40
MI 16 pumps datasheet.....	42
MI 20 pumps datasheet.....	44
MI 32 pumps datasheet.....	46
MI 42 pumps datasheet.....	48

Vertical immersion pumps for coolants - 50 Hz



Vertical immersion pumps for coolants

Characteristics

MI are non-self priming multistage centrifugal pump. The motor shaft is directly connected with the pump shaft through coupling. According to the requirement, the pump can be equipped with a thermal protection device. In order to meet the requirement of installation depth of the water tank, it is possible to install empty chambers to changing length of the pump. Available lengths for different pump sizes are shown in the product table. All pumps are equipped with IE3 motors.

Application

MI is used for conveying cooling liquid, lubricating liquid and condensation water of machine tools, industrial cleaning equipment or other cases that application of immersed pump is suitable. MI is applicable to various temperature, flow and pressure ranges. In particular, it is applicable to lathes, grinding machines, processing centers, cooling devices, industrial cleaning equipment, filtering systems, etc.

For different uses, please consult our Technical Office.

Operation conditions

Clean non-explosive liquid without solid grains and fibers; can be used for conveying of water, cooling water solution and cutting lubricating liquid.

Liquid temperature:

- Normal temperature type: -15°C~+70°C
- Warm water type: -15°C~+120°C

Definition of model

MIF / MIX / MIN

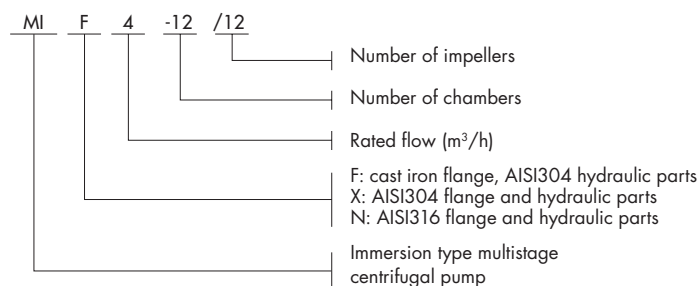

Performance

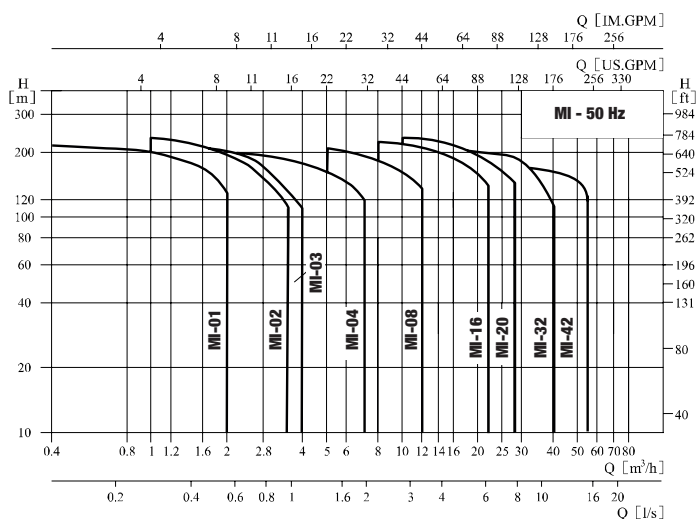

Range of products

Description	MI01	MI02	MI03	MI04	MI08	MI16	MI20	MI32	MI42
Nominal volumetric delivery (m ³ /h)	1	2	3	4	8	16	20	32	42
Nominal volumetric delivery (l/s)	0,28	0,56	0,83	1,1	2,2	4,4	5,6	8,9	11,7
Range of flow (m ³ /h)	0,4-2	1-3,5	1,2-4	1,5-7	5-12	8-22	10-28	16-40	25-55
Range of flow (l/s)	0,11-0,56	0,28-0,97	0,33-1,1	0,42-1,9	1,4-3,3	2,2-6,1	2,8-7,8	4,4-11,1	6,9-15,3
Max delivery head (bar)	21	23	22	21	21	22	23	21	14
Rated power (kW)	0,37-2,2	0,37-3	0,37-3	0,37-4,7	0,75-7,5	2,2-15	2,2-18,5	2,2-22	4-22
Temperature (°C)	-15 ÷ +120								
Max efficiency (%)	44	46	54	57	62	66	69	73	75

Vertical immersion pumps

**Type MI 01
MI 02
MI 03
MI 04
MI 08
MI 16
MI 20**

MI 01-02-03-04-08-16-20

MIF

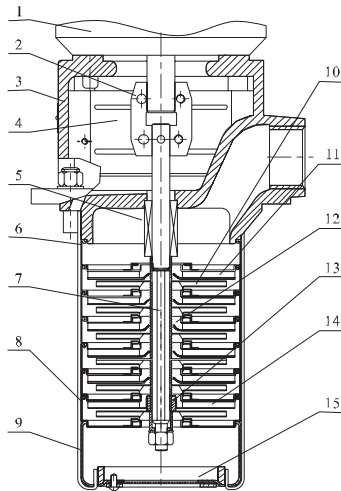

MIX - MIN

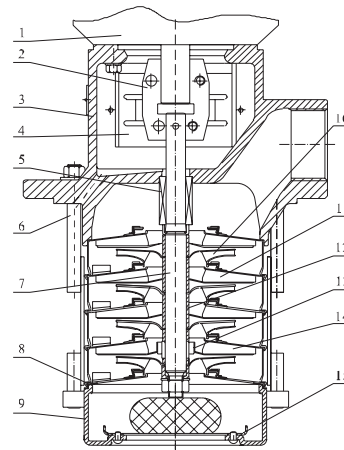

MI 01-02-03-04

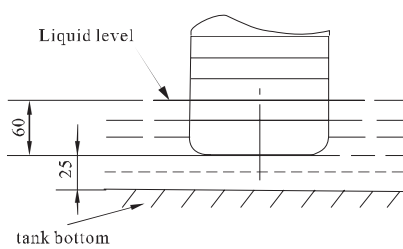

MI 08-16-20

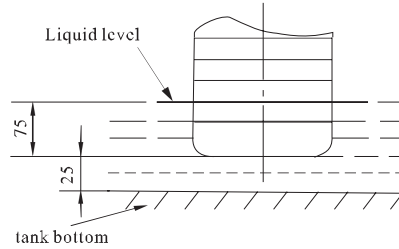

Spare parts nomenclature

Component	Material	AISI/ASTM
1 Motor		
2 Coupling	Carbon steel	
3 MIF Pump head	Cast iron	ASTM25B
3 MIX - MIN Pump head	Stainless steel	AISI304 / AISI316
4 Coupling guard	Stainless steel	AISI304 / AISI316
5 Mechanical seal		
6 Straps	Stainless steel	AISI304 / AISI316
7 Shaft	Stainless steel	AISI316
8 Inducer	Stainless steel	AISI304 / AISI316
9 Suction head	Stainless steel	AISI304 / AISI316
10 Impeller	Stainless steel	AISI304 / AISI316
11 Diffuser	Stainless steel	AISI304 / AISI316
12 Impeller sleeve	Stainless steel	AISI304 / AISI316
13 Bearing	Tungsten carbide	
14 Support diffuser	Stainless steel	AISI304 / AISI316
15 Strainer	Stainless steel	AISI304 / AISI316

MI 32-42

MIF - MIX - MIN

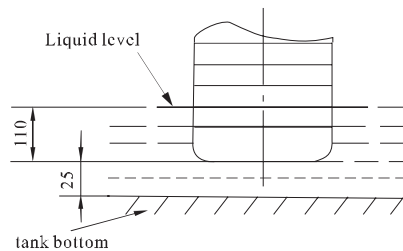
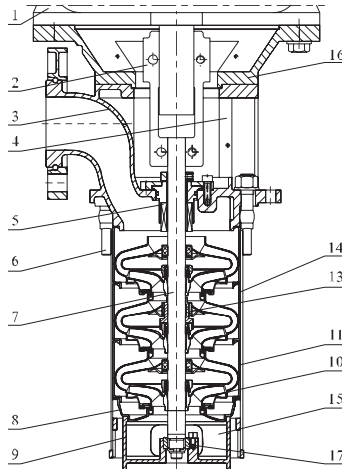

Spare parts nomenclature

Component	Material	AISI/ASTM
1 Motor		
2 Coupling	Carbon steel	
3 MIF Pump head	Cast iron	ASTM25B
3 MIX - MIN Pump head	Stainless steel	AISI304 / AISI316
4 Coupling guard	Stainless steel	AISI304 / AISI316
5 Mechanical seal		
6 Straps	Stainless steel	AISI304 / AISI316
7 Shaft	Stainless steel	AISI431 / AISI304 / AISI316
8 Inducer	Stainless steel	AISI304 / AISI316
9 Suction head	Stainless steel	AISI304 / AISI316
10 Impeller	Stainless steel	AISI304 / AISI316
11 Diffuser	Stainless steel	AISI304 / AISI316
12 Impeller sleeve	Stainless steel	AISI304 / AISI316
13 Bearing	Tungsten carbide	
14 Support diffuser	Stainless steel	AISI304 / AISI316
15 Strainer	Stainless steel	AISI304 / AISI316

Empty chambers availability

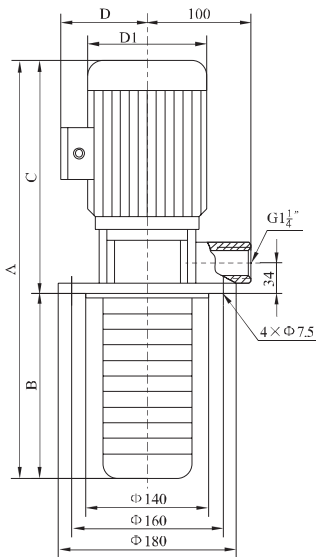

Number of chambers	Number of impellers																L (mm)								
	2	3	4	5	6	7	8	9	10	11	12	13	15	17	19	21		23	25	27	30	33	36		
2	●																							123	
3	○	●																						141	
4	○	○	●																					159	
5	○	○	○	●																				177	
6	○	○	○	○	●																			195	
7	○	○	○	○	○	●																		213	
8	○	○	○	○	○	○	●																	231	
9	○	○	○	○	○	○	○	●																249	
10	○	○	○	○	○	○	○	○	●															267	
11	○	○	○	○	○	○	○	○	○	●														285	
12	○	○	○	○	○	○	○	○	○	○	●													303	
13	○	○	○	○	○	○	○	○	○	○	○	●												321	
15	○	○	○	○	○	○	○	○	○	○	○	○	●											357	
17	○	○	○	○	○	○	○	○	○	○	○	○	○	●										393	
19	○	○	○	○	○	○	○	○	○	○	○	○	○	○	●									429	
21	○	○	○	○	○	○	○	○	○	○	○	○	○	○	○	●								465	
23	○	○	○	○	○	○	○	○	○	○	○	○	○	○	○	○	●							501	
25	○	○	○	○	○	○	○	○	○	○	○	○	○	○	○	○	○	●						537	
27	○	○	○	○	○	○	○	○	○	○	○	○	○	○	○	○	○	○	●					573	
30	○	○	○	○	○	○	○	○	○	○	○	○	○	○	○	○	○	○	○	○	●			627	
33	○	○	○	○	○	○	○	○	○	○	○	○	○	○	○	○	○	○	○	○	○	○	●	681	
36	○	○	○	○	○	○	○	○	○	○	○	○	○	○	○	○	○	○	○	○	○	○	○	●	735
Motor (kW)	0,37			0,55			0,75			1,1			1,5			1,8			2,2						

Dimensions and performances

Model	Dimensions					Weight (Kg)	Motor		Q (m³/h)	H (m)								
	A	B	C	D	D1		(kW)	(hp)		0,4	0,6	0,8	1	1,2	1,4	1,6	1,8	2
MI01-2/2	430	123	307	112	141	15	0,37	0,5	13	12,5	12	11,5	11	10,5	10	9,5	9	
MI01-3/3	448	141	307	112	141	15	0,37	0,5	19	18	17,5	17	16,5	16	15	14	12	
MI01-4/4	466	159	307	112	141	15	0,37	0,5	24	23,5	23	22,5	21,5	21	19	18	16	
MI01-5/5	484	177	307	112	141	16	0,37	0,5	30	39,6	29	28	27	26	24	22	20	
MI01-6/6	502	195	307	112	141	16	0,37	0,5	36	35,5	35	33,5	33	31	28	26	23	
MI01-7/7	520	213	307	112	141	16	0,37	0,5	42	41	40,5	39	38	36	33	30	27	
MI01-8/8	538	231	307	112	141	17	0,55	0,75	48	47	46	45	43	41	38	34	30	
MI01-9/9	556	249	307	112	141	17	0,55	0,75	54	53	52	51	49	46	43	39	33	
MI01-10/10	574	267	307	112	141	17	0,55	0,75	60	59	58	57	54	51	48	43	36	
MI01-11/11	592	285	307	112	141	17	0,55	0,75	66	65	63	61	59	56	52	47	40	
MI01-12/12	659	303	356	125	160	20	0,75	1	72	71	69	67	64	61	57	51	44	
MI01-13/13	677	321	356	125	160	20	0,75	1	78	77	75	73	69	66	62	55	47	
MI01-15/15	713	357	356	125	160	20	0,75	1	89	88	86	84	79	76	71	63	55	
MI01-17/17	749	393	356	125	160	22	1,1	1,5	101	99	97	95	89	86	80	71	62	
MI01-19/19	785	429	356	125	160	22	1,1	1,5	113	110	108	106	99	96	89	79	69	
MI01-21/21	821	465	356	125	160	23	1,5*	2	124	122	120	117	110	106	98	87	75	
MI01-23/23	857	501	356	125	160	23	1,5*	2	137	133	131	128	121	116	107	96	82	
MI01-25/25	919	537	382	129	180	30	1,5	2	149	145	143	139	131	126	116	104	89	
MI01-27/27	955	573	382	129	180	30	1,8	2,5	161	157	155	150	141	136	125	112	95	
MI01-30/30	1009	627	382	129	180	31	1,8	2,5	178	175	171	166	157	150	139	124	106	
MI01-33/33	1088	681	407	129	180	34	2,2	3	196	192	188	183	173	165	154	137	118	
MI01-36/36	1142	735	407	129	180	35	2,2	3	214	210	205	200	190	181	169	151	130	

* Motor MEC 80

Performance curve ISO9906:2012 Grade 3B

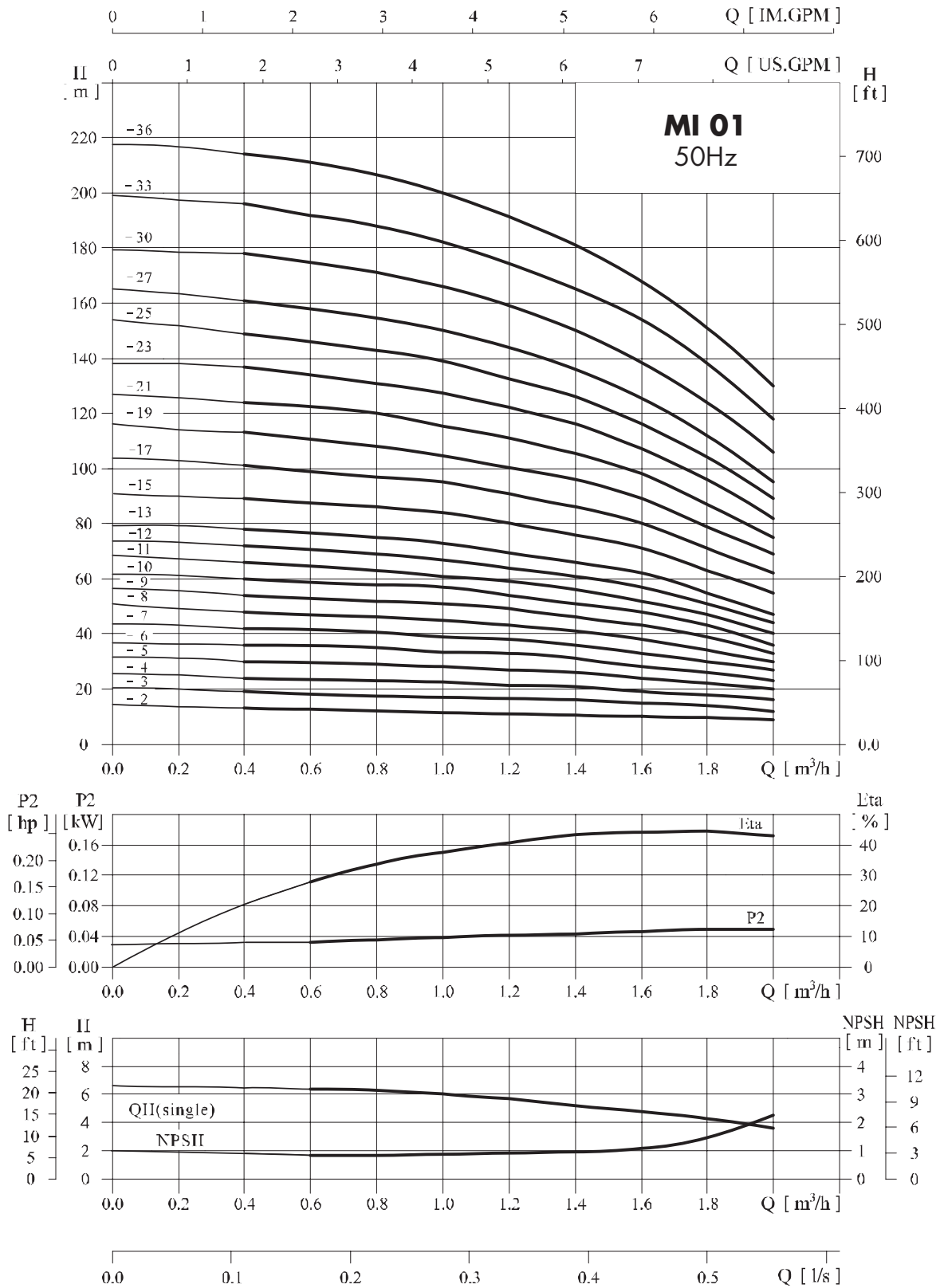

Empty chambers availability

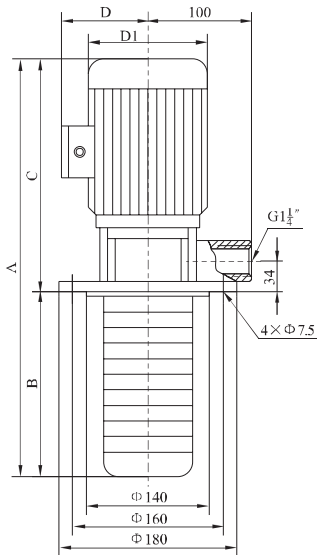

Number of chambers	Number of impellers												L (mm)	
	2	3	4	5	6	7	9	11	13	15	18	22		26
2	●													123
3	○	●												141
4	○	○	●											159
5	○	○	○	●										177
6	○	○	○	○	●									195
7	○	○	○	○	○	●								213
9	○	○	○	○	○	○	●							249
11	○	○	○	○	○	○	○	●						285
13	○	○	○	○	○	○	○	○	●					321
15	○	○	○	○	○	○	○	○	○	●				357
18	○	○	○	○	○	○	○	○	○	○	●			411
22	○	○	○	○	○	○	○	○	○	○	○	●		483
26	○	○	○	○	○	○	○	○	○	○	○	○	●	555
Motor (kW)	0,37	0,55	0,75	1,1	1,5	1,8	2,2	2,6	3					

Dimensions and performances

Model	Dimensions					Weight (Kg)	Motor		Q (m³/h)	H (m)							
	A	B	C	D	D1		(kW)	(hp)		1	1,2	1,6	2	2,4	2,8	3,2	3,5
MI02-2/2	430	123	307	112	141	15	0,37	0,5	H (m)	18	17	16	15	13	12	10	8
MI02-3/3	448	141	307	112	141	15	0,37	0,5		27	26	24	22	20	18	15	12
MI02-4/4	466	159	307	112	141	17	0,55	0,75		36	35	33	30	26	24	20	16
MI02-5/5	484	177	307	112	141	17	0,55	0,75		45	43	40	37	33	30	24	20
MI02-6/6	551	195	356	125	160	20	0,75	1		53	52	50	45	40	36	30	24
MI02-7/7	569	213	356	125	160	20	0,75	1		63	61	57	52	47	41	35	28
MI02-9/9	605	249	356	125	160	22	1,1	1,5		80	78	73	67	61	54	45	37
MI02-11/11	641	285	356	125	160	22	1,5*	2		98	95	89	82	73	64	54	44
MI02-13/13	703	321	382	129	180	29	1,5	2		116	114	106	98	89	78	65	52
MI02-15/15	739	357	382	129	180	29	1,8	2,5		134	130	123	112	100	90	73	60
MI02-18/18	818	411	407	129	180	33	2,2	3		161	157	148	136	121	108	91	76
MI02-22/22	890	483	407	129	180	33	2,6	3,5		197	192	180	165	148	130	110	90
MI02-26/26	1000	555	445	141	200	41	3	4		232	228	214	198	179	158	130	110

* Motor MEC 80

Performance curve ISO9906:2012 Grade 3B

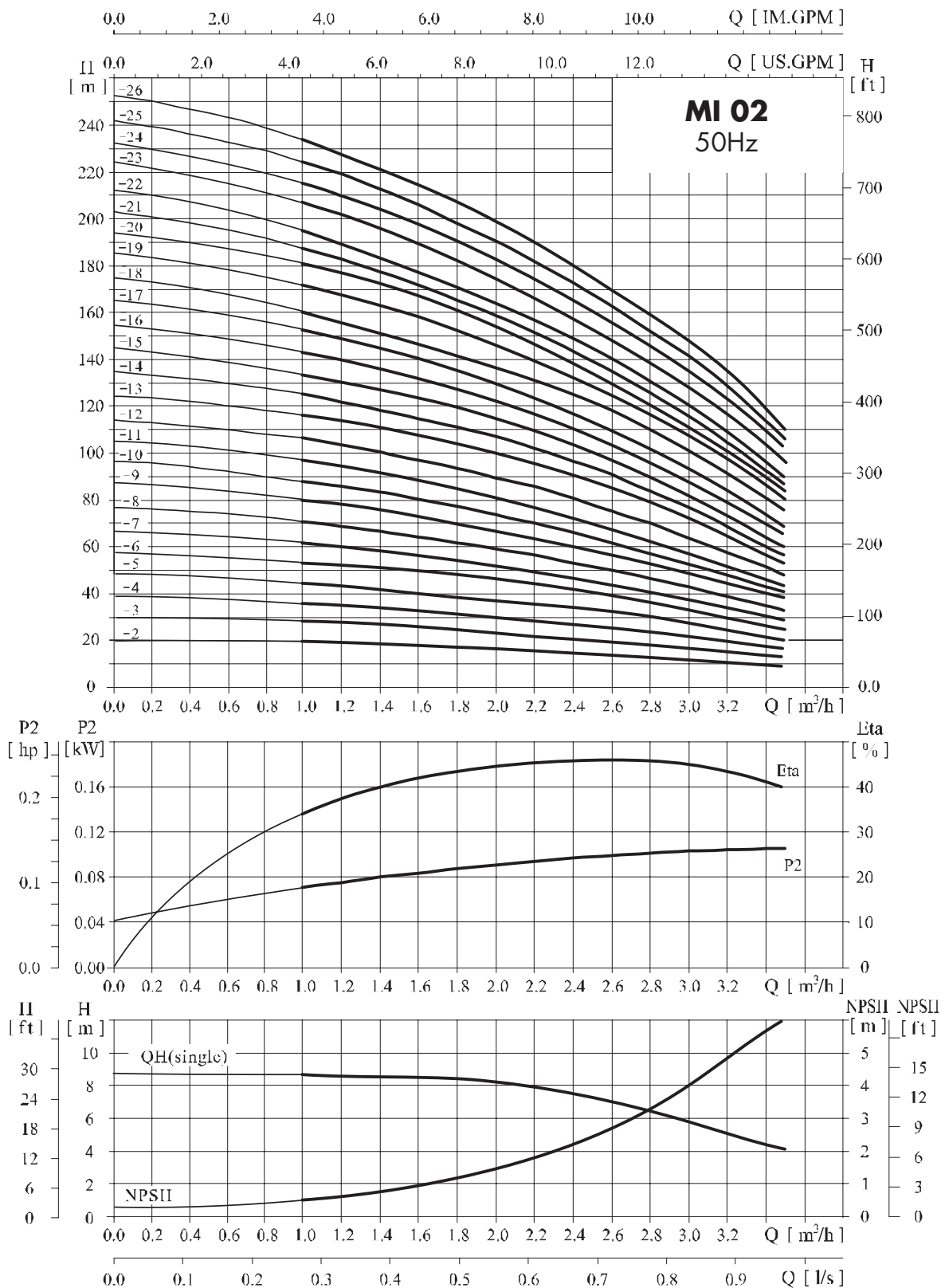

Empty chambers availability

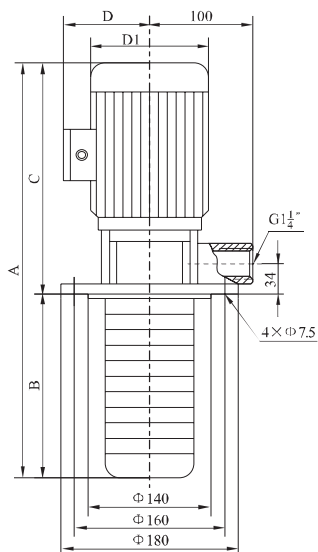

Number of chambers	Number of impellers																L (mm)										
	2	3	4	5	6	7	8	9	10	11	12	13	15	17	19	21		23	25	27	29	31	33	36			
2	●																								123		
3	○	●																							141		
4	○	○	●																						159		
5	○	○	○	●																					177		
6	○	○	○	○	●																				195		
7	○	○	○	○	○	●																			213		
8	○	○	○	○	○	○	○	●																	231		
9	○	○	○	○	○	○	○	○	○	●															249		
10	○	○	○	○	○	○	○	○	○	○	○	○	○	○	○	○	○	○	○	○	○	○	○	○	267		
11	○	○	○	○	○	○	○	○	○	○	○	○	○	○	○	○	○	○	○	○	○	○	○	○	285		
12	○	○	○	○	○	○	○	○	○	○	○	○	○	○	○	○	○	○	○	○	○	○	○	○	303		
13	○	○	○	○	○	○	○	○	○	○	○	○	○	○	○	○	○	○	○	○	○	○	○	○	321		
15	○	○	○	○	○	○	○	○	○	○	○	○	○	○	○	○	○	○	○	○	○	○	○	○	357		
17	○	○	○	○	○	○	○	○	○	○	○	○	○	○	○	○	○	○	○	○	○	○	○	○	393		
19	○	○	○	○	○	○	○	○	○	○	○	○	○	○	○	○	○	○	○	○	○	○	○	○	429		
21	○	○	○	○	○	○	○	○	○	○	○	○	○	○	○	○	○	○	○	○	○	○	○	○	465		
23	○	○	○	○	○	○	○	○	○	○	○	○	○	○	○	○	○	○	○	○	○	○	○	○	501		
25	○	○	○	○	○	○	○	○	○	○	○	○	○	○	○	○	○	○	○	○	○	○	○	○	537		
27	○	○	○	○	○	○	○	○	○	○	○	○	○	○	○	○	○	○	○	○	○	○	○	○	573		
29	○	○	○	○	○	○	○	○	○	○	○	○	○	○	○	○	○	○	○	○	○	○	○	○	609		
31	○	○	○	○	○	○	○	○	○	○	○	○	○	○	○	○	○	○	○	○	○	○	○	○	645		
33	○	○	○	○	○	○	○	○	○	○	○	○	○	○	○	○	○	○	○	○	○	○	○	○	681		
36	○	○	○	○	○	○	○	○	○	○	○	○	○	○	○	○	○	○	○	○	○	○	○	○	735		
Motor (kW)	0,37			0,55			0,75			1,1			1,5			1,8			2,2			2,6			3		

Dimensions and performances

Model	Dimensions					Weight (Kg)	Motor		Q (m³/h)	H (m)									
	A	B	C	D	D1		(kW)	(hp)		1,2	1,6	2	2,4	2,8	3	3,2	3,6	4	
MI03-2/2	430	123	307	112	141	15	0,37	0,5	H (m)	12,5	11,5	11	10,5	10	9	8	7	6	
MI03-3/3	448	141	307	112	141	15	0,37	0,5		19	18,5	17,5	16,5	15	14	13	11	9	
MI03-4/4	466	159	307	112	141	15	0,37	0,5		25	24	23	21,5	20	19	18	15	12	
MI03-5/5	484	177	307	112	141	16	0,37	0,5		31	30	29	27	25	23	22	19	16	
MI03-6/6	502	195	307	112	141	17	0,55	0,75		36	35	34	32	30	28	27	23	19	
MI03-7/7	520	213	307	112	141	17	0,55	0,75		43	41	39	37	34	32	31	27	22	
MI03-8/8	587	231	356	125	160	19	0,75	1		49	47	45	43	39	37	35	31	25	
MI03-9/9	605	249	356	125	160	20	0,75	1		55	53	51	48	45	42	40	35	28	
MI03-10/10	623	267	356	125	160	20	0,75	1		61	59	57	54	50	47	45	39	31	
MI03-11/11	641	285	356	125	160	21	1,1	1,5		67	64	61	58	54	51	49	42	34	
MI03-12/12	659	303	356	125	160	21	1,1	1,5		73	70	67	63	58	55	52	45	37	
MI03-13/13	677	321	356	125	160	22	1,1	1,5		78	76	73	69	64	60	57	49	40	
MI03-15/15	713	357	356	125	160	22	1,5*	2		90	88	84	79	73	69	66	57	46	
MI03-17/17	775	393	382	129	180	28	1,5	2		103	100	96	90	83	79	75	64	52	
MI03-19/19	811	429	382	129	180	29	1,8	2,5		115	112	107	100	92	88	83	72	58	
MI03-21/21	872	465	407	129	180	32	2,2	3		128	124	119	112	102	98	91	79	64	
MI03-23/23	908	501	407	129	180	32	2,2	3		140	135	130	122	112	107	100	86	70	
MI03-25/25	944	537	407	129	180	33	2,2	3		151	147	141	131	122	116	109	94	76	
MI03-27/27	980	573	407	129	180	33	2,6	3,5		164	159	152	143	132	124	117	101	82	
MI03-29/29	1016	609	407	129	180	33	2,6	3,5		175	170	163	153	142	133	126	109	88	
MI03-30/30	1090	645	445	141	200	40	3	4		187	182	175	165	153	142	135	116	94	
MI03-33/33	1126	681	445	141	200	41	3	4		199	194	187	176	163	151	145	125	100	
MI03-36/36	1180	735	445	141	200	41	3	4		218	212	204	192	178	168	159	137	109	

* Motor MEC 80

Performance curve ISO9906:2012 Grade 3B

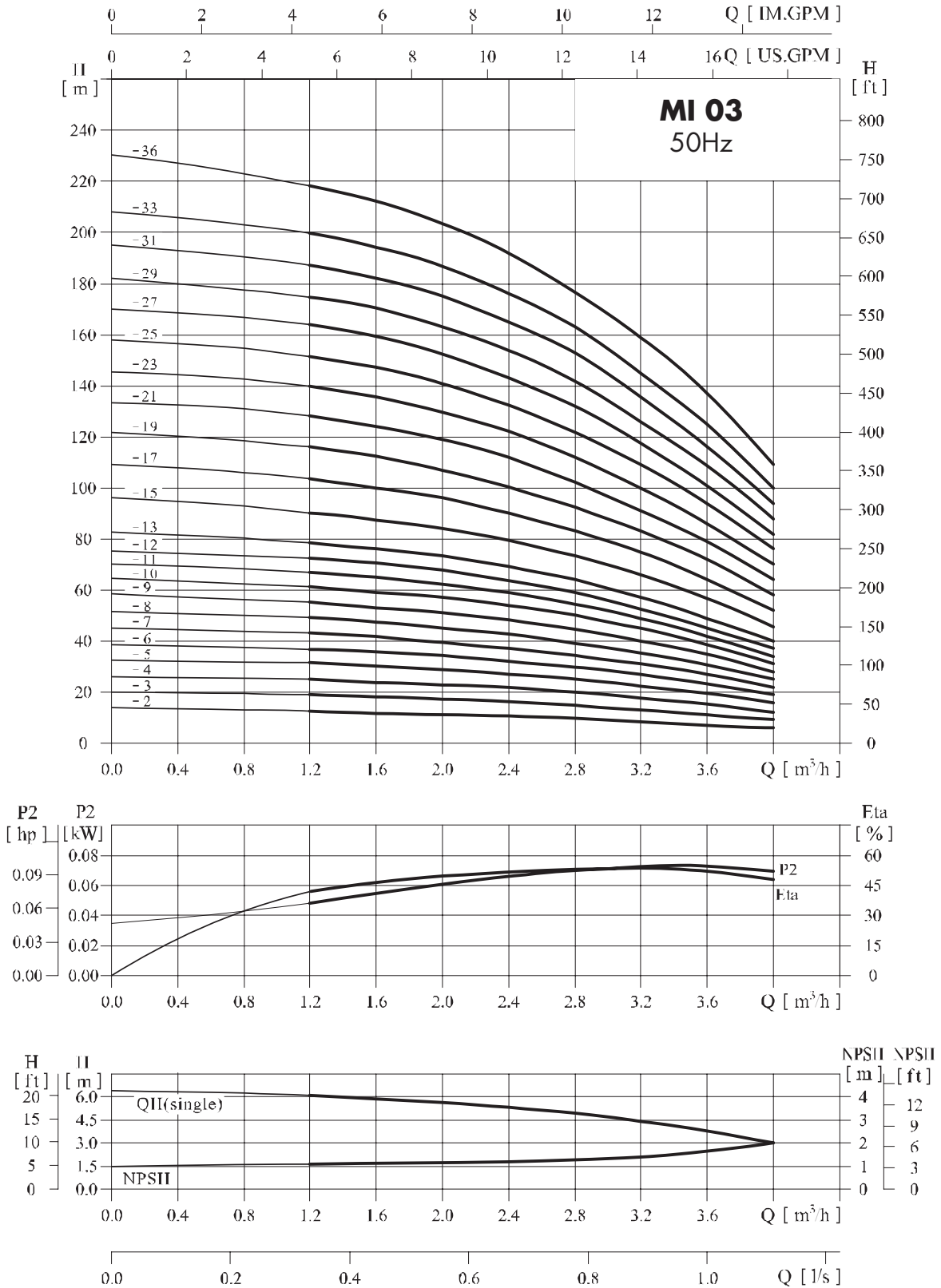

Empty chambers availability

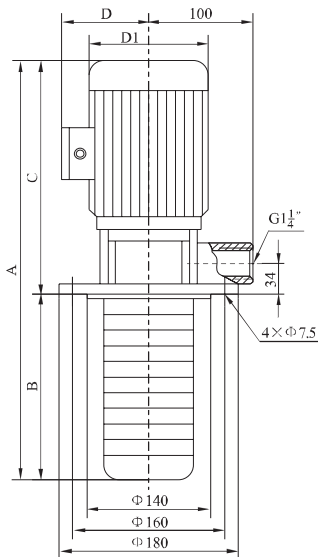

Number of chambers	Number of impellers											L (mm)		
	2	3	4	5	6	7	8	10	12	14	16		19	22
2	●													148
3	○	●												175
4	○	○	●											202
5	○	○	○	●										229
6	○	○	○	○	●									256
7	○	○	○	○	○	●								283
8	○	○	○	○	○	○	●							310
10	○	○	○	○	○	○	○	●						364
12	○	○	○	○	○	○	○	○	●					418
14	○	○	○	○	○	○	○	○	○	●				472
16	○	○	○	○	○	○	○	○	○	○	●			526
19	○	○	○	○	○	○	○	○	○	○	○	●		607
22	○	○	○	○	○	○	○	○	○	○	○	○	●	688
Motor (kW)	0,37	0,55	0,75	1,1	1,5	2,2	2,6	3	4	4,7				

Dimensions and performances

Model	Dimensions					Weight (Kg)	Motor		Q (m³/h)	H (m)						
	A	B	C	D	D1		(kW)	(hp)		1,5	2	3	4	5	6	7
MI04-2/2	455	148	307	112	141	15	0,37	0,5	H (m)	19	18	17	15	13	12	8
MI04-3/3	482	175	307	112	141	15	0,55	0,75		28	27	26	24	20	18	13
MI04-4/4	558	202	356	125	160	18	0,75	1		38	36	34	32	27	24	19
MI04-5/5	585	229	356	125	160	20	1,1	1,5		47	45	43	40	34	31	23
MI04-6/6	612	256	356	125	160	21	1,1	1,5		56	54	52	48	41	37	28
MI04-7/7	665	283	382	129	180	27	1,5	2		66	63	61	56	48	43	33
MI04-8/8	692	310	382	129	180	28	1,5	2		74	72	70	64	55	50	38
MI04-10/10	771	364	407	129	180	30	2,2	3		96	90	87	81	71	62	48
MI04-12/12	825	418	407	129	180	30	2,6	3,5		114	108	104	95	85	75	58
MI04-14/14	917	472	445	141	200	35	3	4		136	126	122	112	101	89	68
MI04-16/16	971	526	445	141	200	35	3	4		152	144	140	129	115	101	78
MI04-19/19	1075	607	468	168	224	40	4	5,5		183	171	168	153	137	122	93
MI04-22/22	1156	688	468	168	224	41	4,7	6,4		211	200	192	178	160	138	108

Performance curve ISO9906:2012 Grade 3B

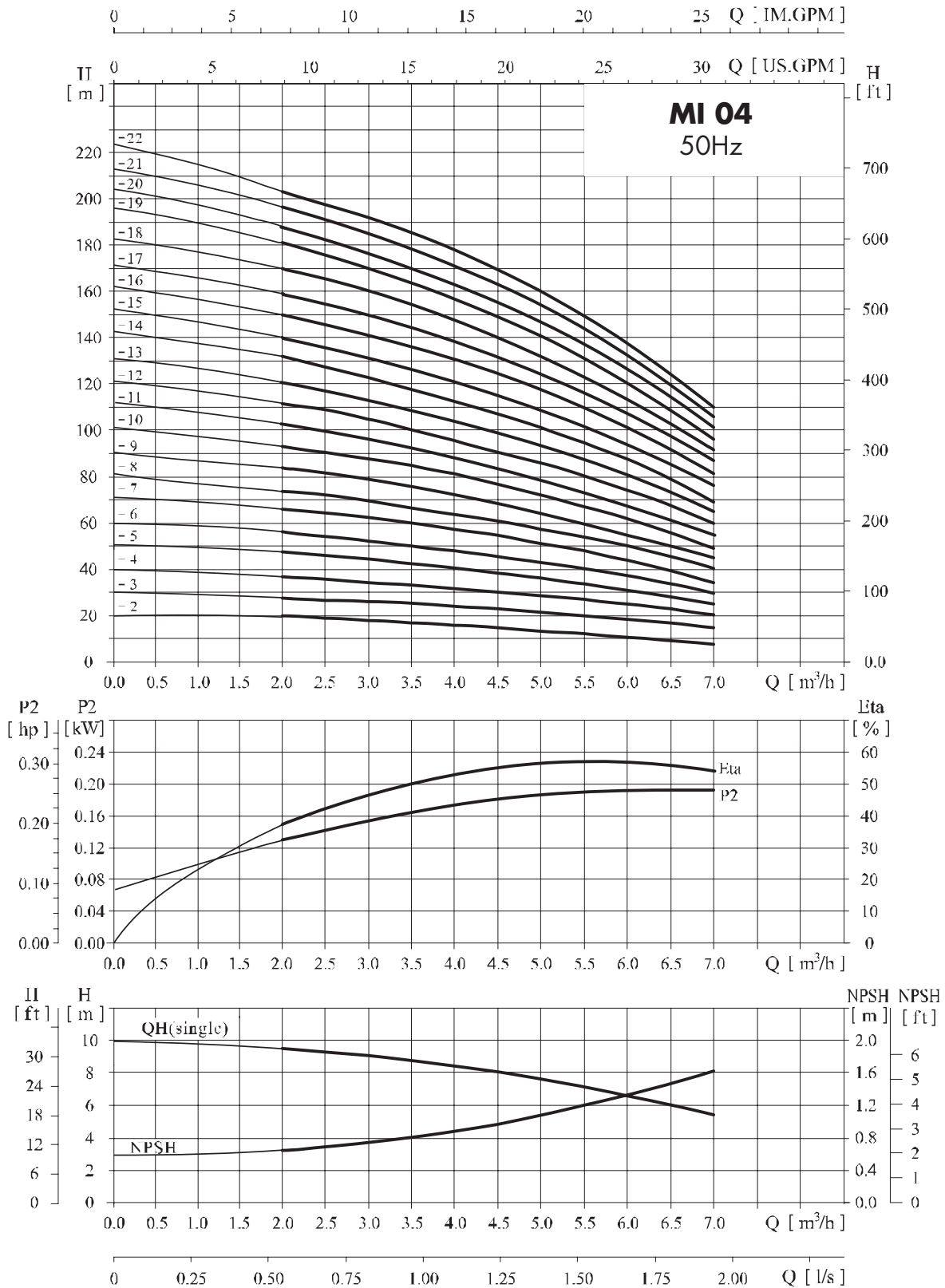

Empty chambers availability

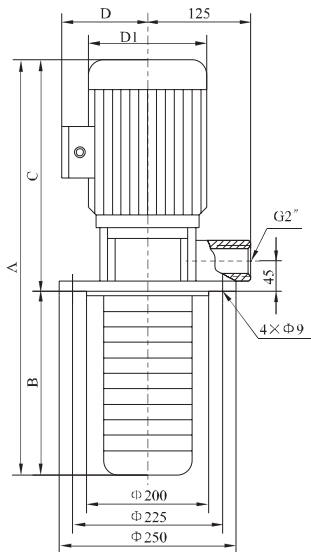

MI 08 - 50Hz Number of chambers	Number of impellers										L (mm)		
	2	3	4	5	6	8	10	12	14	16		18	20
2	●												150
3	○	●											180
4	○	○	●										210
5	○	○	○	●									240
6	○	○	○	○	●								270
8	○	○	○	○	○	●							330
10	○	○	○	○	○	○	●						390
12	○	○	○	○	○	○	○	●					450
14	○	○	○	○	○	○	○	○	●				510
16	○	○	○	○	○	○	○	○	○	●			570
18	○	○	○	○	○	○	○	○	○	○	●		630
20	○	○	○	○	○	○	○	○	○	○	○	●	690
Motor (kW)	0,75	1,1	1,5	2,2	3	4	4,7	5,5	7,5				

Dimensions and performances

Model	Dimensions					Weight (Kg)	Motor		Q (m³/h)	H (m)							
	A	B	C	D	D1		(kW)	(hp)		5	6	7	8	9	10	11	12
MI08-2/2	514	150	364	125	160	22	0,75	1	H (m)	20	19,15	19	18	17	16	14	13
MI08-3/3	544	180	364	125	160	27	1,1	1,5		30	29,5	28,5	27	25	24	21	19
MI08-4/4	598	210	388	129	180	27	1,5	2		41	39,5	38	36	34	32	28	26
MI08-5/5	653	240	413	129	180	36	2,2	3		52	50	48	45	42	40	36	32
MI08-6/6	683	270	413	129	180	37	2,2	3		62	60	57	54	51	48	43	39
MI08-8/8	781	330	451	141	200	42	3	4		83	80	77	73	69	65	58	52
MI08-10/10	864	390	474	168	224	52	4	5,5		104	100	97	92	87	81	73	65
MI08-12/12	924	450	474	168	224	53	4,7	6,4		124	120	116	111	104	92	87	78
MI08-14/14	1095	510	585	196	260	75	5,5	7,5		145	141	136	130	122	113	102	92
MI08-16/16	1155	570	585	196	260	77	7,5	10		166	161	156	148	139	130	118	106
MI08-18/18	1215	630	585	196	260	85	7,5	10		187	182	175	167	157	146	134	120
MI08-20/20	1275	690	585	196	260	87	7,5	10		208	202	195	186	175	163	150	135

Performance curve ISO9906:2012 Grade 3B

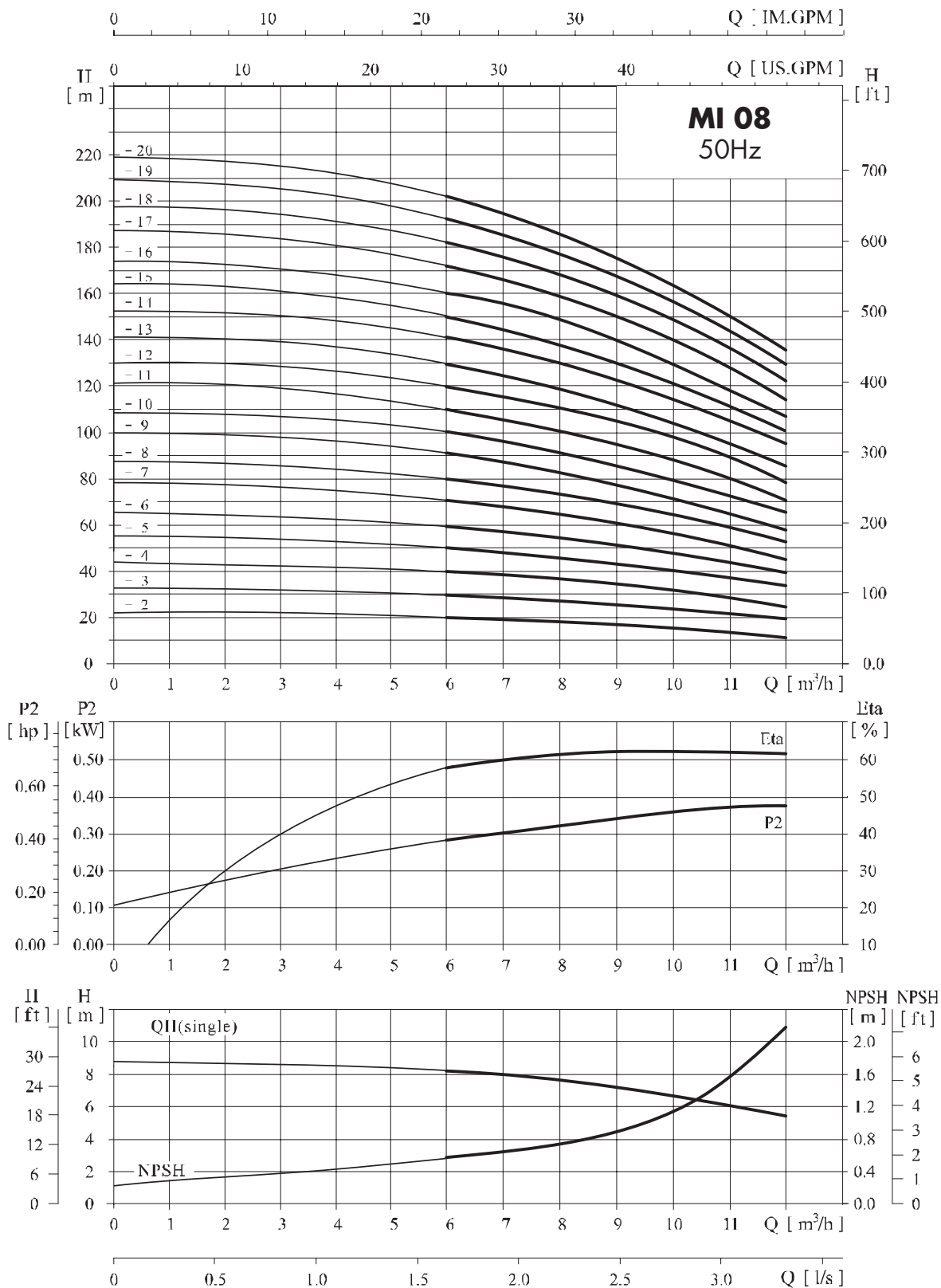

Empty chambers availability

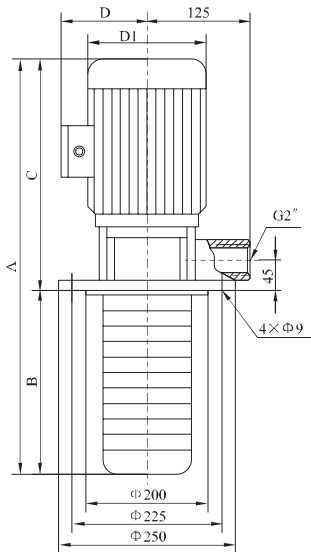

Number of chambers	Number of impellers											L (mm)	
	2	3	4	5	6	7	8	10	12	14	16		
2	●												180
3	○	●											225
4	○	○	●										270
5	○	○	○	●									315
6	○	○	○	○	●								360
7	○	○	○	○	○	●							405
8	○	○	○	○	○	○	●						450
10	○	○	○	○	○	○	○	●					540
12	○	○	○	○	○	○	○	○	●				630
14	○	○	○	○	○	○	○	○	○	●			720
16	○	○	○	○	○	○	○	○	○	○	●		810
Motor (kW)	2,2	3	4	5,5	7,5	11	15						

Dimensions and performances

Model	Dimensions					Weight (Kg)	Motor		Q (m³/h)	H (m)							
	A	B	C	D	D1		(kW)	(hp)		8	10	12	14	16	18	20	22
MI16-2/2	593	180	413	129	180	37	2,2	3	H (m)	27	26	25	24	22	21	19	16
MI16-3/3	676	225	451	141	200	47	3	4		41	40	38	37	34	32	29	25
MI16-4/4	744	270	474	168	224	52	4	5,5		54	53	52	49	46	43	38	34
MI16-5/5	900	315	585	196	260	67	5,5	7,5		68	67	65	62	58	54	48	43
MI16-6/6	945	360	585	196	260	72	5,5	7,5		82	80	78	74	70	64	58	52
MI16-7/7	990	405	585	196	260	77	7,5	10		96	95	91	87	82	76	68	61
MI16-8/8	1035	450	585	196	260	78	7,5	10		110	108	104	99	94	86	77	70
MI16-10/10	1238	540	698	235	310	135	11	15		138	136	131	125	118	109	97	87
MI16-12/12	1328	630	698	235	310	140	11	15		166	162	157	150	141	130	116	105
MI16-14/14	1418	720	698	235	310	155	15	20		194	190	184	175	166	152	136	122
MI16-16/16	1508	810	698	235	310	162	15	20		222	217	210	200	189	174	156	140

Performance curve ISO9906:2012 Grade 3B

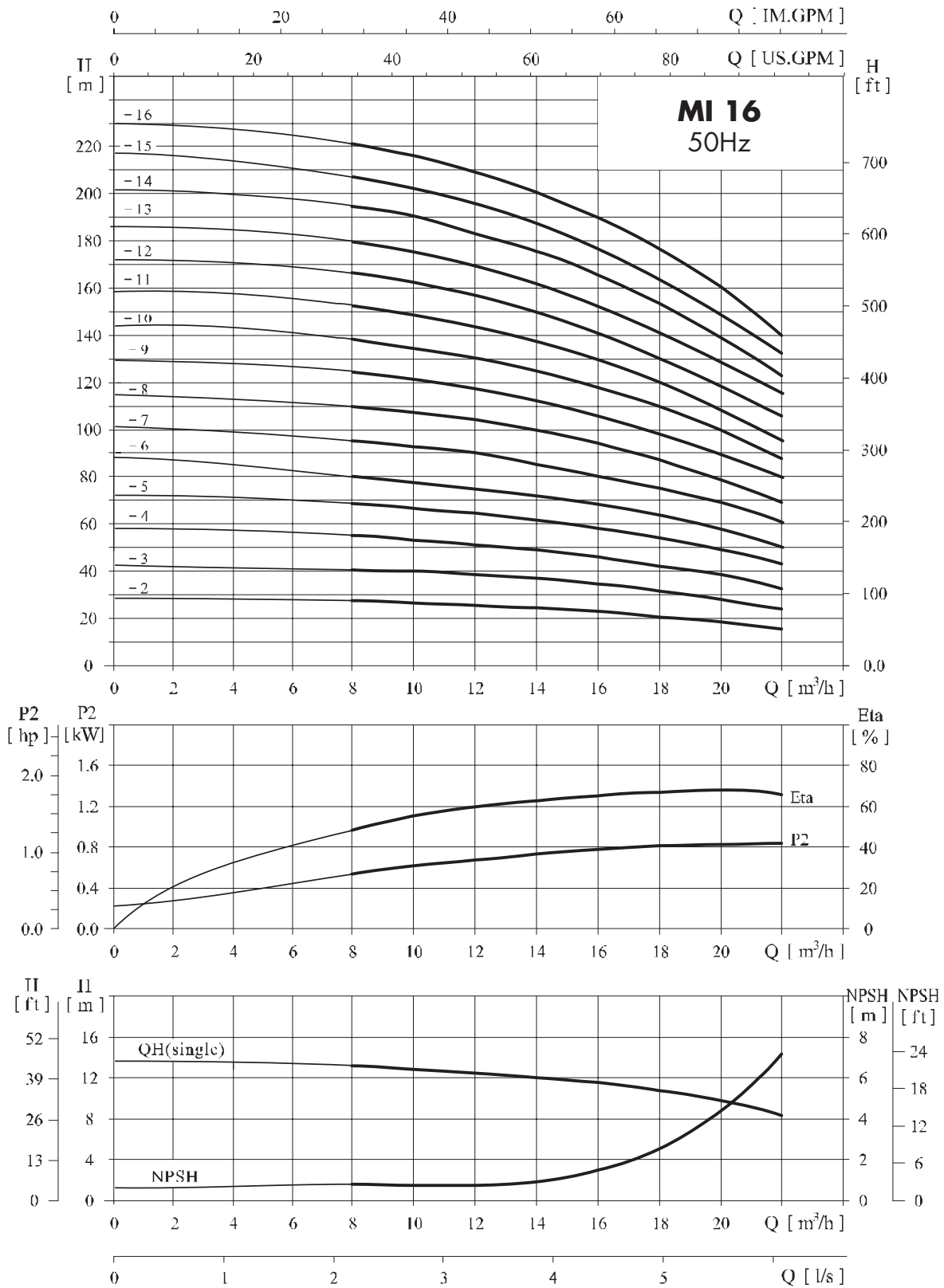

Empty chambers availability

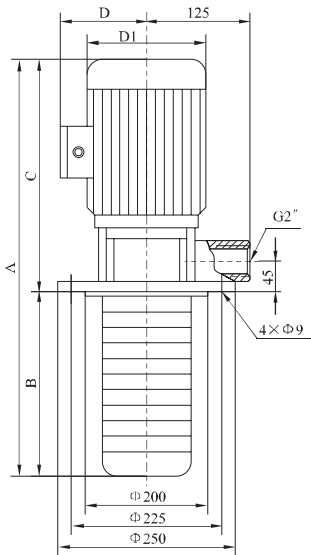

Number of chambers	Number of impellers											L (mm)	
	2	3	4	5	6	7	8	10	12	14	17		
2	●												180
3	○	●											225
4	○	○	●										270
5	○	○	○	●									315
6	○	○	○	○	●								360
7	○	○	○	○	○	●							405
8	○	○	○	○	○	○	●						450
10	○	○	○	○	○	○	○	●					540
12	○	○	○	○	○	○	○	○	●				630
14	○	○	○	○	○	○	○	○	○	●			720
17	○	○	○	○	○	○	○	○	○	○	●		855
Motor (kW)	2,2	4	5,5	7,5	11	15	18,5						

Dimensions and performances

Model	Dimensions					Weight (Kg)	Motor		Q (m³/h)	H (m)									
	A	B	C	D	D1		(kW)	(hp)		10	12	14	16	18	20	22	24	26	28
MI20-2/2	593	180	413	129	180	37	2,2	3	H (m)	27	26,5	26	25	24	23	22	20	18	15
MI20-3/3	699	225	474	168	224	50	4	5,5		40	39,5	39	38	37	35	33	30	27	24
MI20-4/4	855	270	585	196	260	65	5,5	7,5		54	53	52	51	49	47	44	41	37	33
MI20-5/5	900	315	585	196	260	67	5,5	7,5		67	66	64	62	60	58	55	50	45	40
MI20-6/6	945	360	585	196	260	75	7,5	10		81	79	77	75	73	70	66	61	55	49
MI20-7/7	990	405	585	196	260	77	7,5	10		95	93	91	89	86	82	77	71	65	58
MI20-8/8	1148	450	698	235	310	131	11	15		109	107	105	102	99	94	89	82	75	67
MI20-10/10	1238	540	698	235	310	135	11	15		136	134	131	128	124	118	111	103	95	85
MI20-12/12	1328	630	698	235	310	151	15	20		164	162	158	154	149	142	133	124	114	102
MI20-14/14	1418	720	698	235	310	155	15	20		192	189	185	180	174	166	156	145	133	119
MI20-17/17	1603	855	748	235	310	181	18,5	25		234	230	225	219	212	202	190	177	162	145

Performance curve ISO9906:2012 Grade 3B

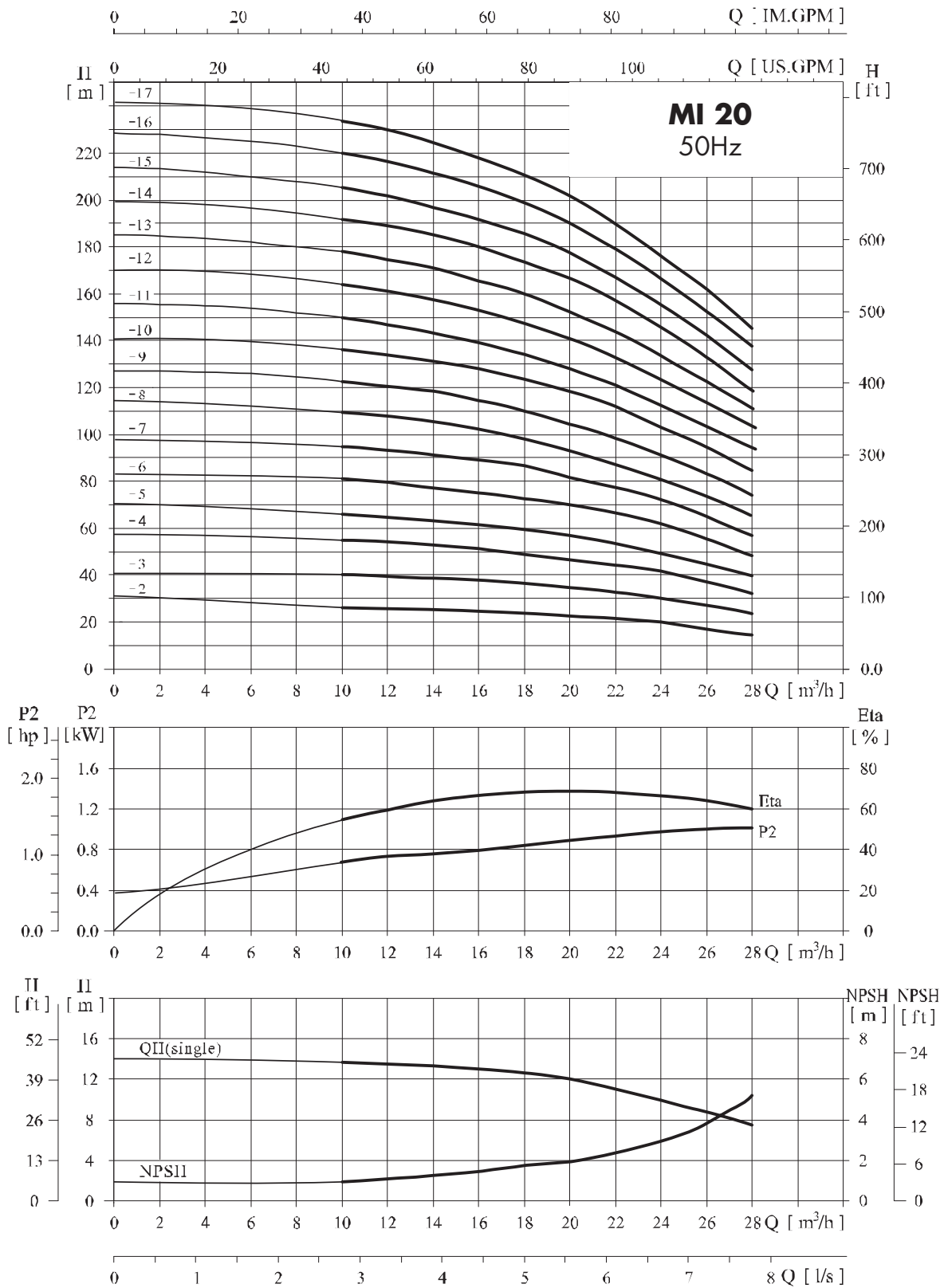

Empty chambers availability

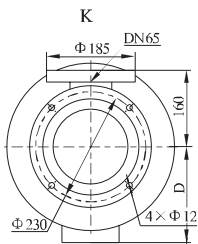
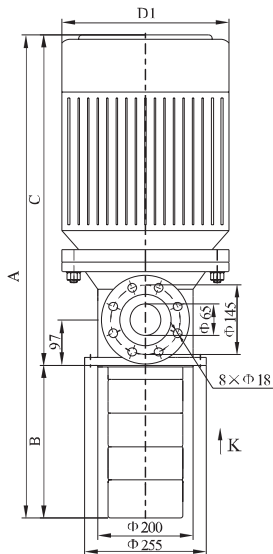

Number of chambers	Number of impellers												L (mm)
	1	2	3	4	5	6	7	8	9	10	11	12	
1	●												186
2	○	●											256
3	○	○	●										326
4	○	○	○	●									396
5	○	○	○	○	●								466
6	○	○	○	○	○	●							536
7	○	○	○	○	○	○	●						606
8	○	○	○	○	○	○	○	●					676
9	○	○	○	○	○	○	○	○	●				746
10	○	○	○	○	○	○	○	○	○	●			816
11	○	○	○	○	○	○	○	○	○	○	●		886
12	○	○	○	○	○	○	○	○	○	○	○	●	956
13	○	○	○	○	○	○	○	○	○	○	○	○	1026
14	○	○	○	○	○	○	○	○	○	○	○	○	1096
Motor (kW)	2,2	4	5,5	7,5	11	15	18,5	22					

Dimensions and performances

Model	Dimensions				Weight (Kg)	Motor (kW)	Motor (hp)	Q (m³/h)	H (m)						
	A	B	C	D					D1	16	20	24	28	32	36
MI32-1/1	615	186	429	129	180	51	2,2	3	18	17	15	14	13	11	8
MI32-2/2	736	256	480	168	224	62	4	5,5	36	34	32	29	27	23	18
MI32-3/3	917	326	591	196	260	70	5,5	7,5	54	51	48	44	40	35	27
MI32-4/4	987	396	591	196	260	77	7,5	10	72	69	65	59	53	47	37
MI32-5/5	1182	466	716	235	310	148	11	15	90	86	81	74	67	59	47
MI32-6/6	1252	536	716	235	310	150	11	15	108	104	97	90	81	72	57
MI32-7/7	1322	606	716	235	310	162	15	20	126	121	113	105	95	85	67
MI32-8/8	1392	676	716	235	310	165	15	20	144	138	130	120	109	97	77
MI32-9/9	1512	746	766	235	310	191	18,5	25	162	156	147	136	124	109	88
MI32-10/10	1582	816	766	235	310	194	18,5	25	182	173	164	152	138	122	98
MI32-11/11	1644	886	793	235	310	230	22	30	200	191	180	168	153	135	109
MI32-12/12	1714	956	793	235	310	234	22	30	218	208	196	184	167	147	120

Performance curve ISO9906:2012 Grade 3B

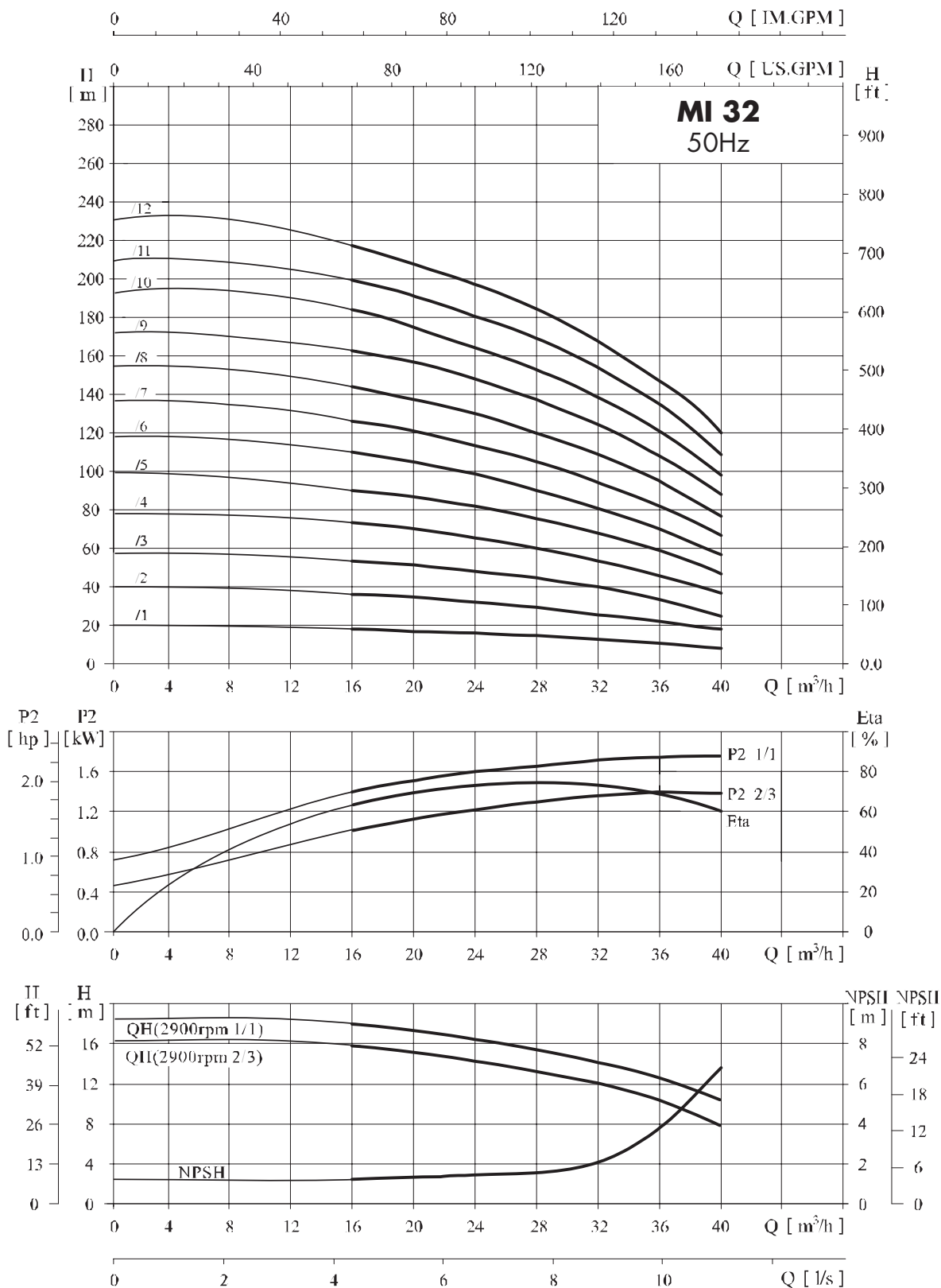

Empty chambers availability

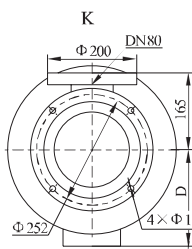
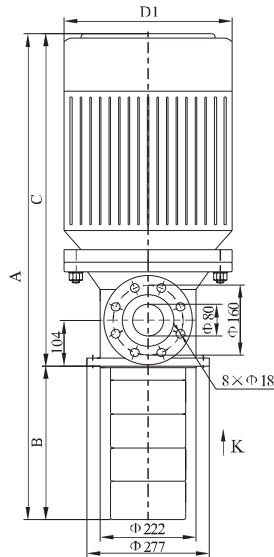

Number of chambers	Number of impellers						L (mm)
	1	2	3	4	5	6	
1	●						198
2	○	●					278
3	○	○	●				358
4	○	○	○	●			438
5	○	○	○	○	●		518
6	○	○	○	○	○	●	598
7	○	○	○	○	○	○	678
8	○	○	○	○	○	○	758
9	○	○	○	○	○	○	838
10	○	○	○	○	○	○	918
11	○	○	○	○	○	○	998
12	○	○	○	○	○	○	1078
13	○	○	○	○	○	○	1158
Motor (kW)	4	7,5	11	15	18,5	22	

Dimensions and performances

Model	Dimensions					Weight (Kg)	Motor		Q (m³/h)	H (m)							
	A	B	C	D	D1		(kW)	(hp)		25	30	35	40	42	45	50	55
MI42-1/1	692	198	494	168	224	65	4	5,5	H (m)	24	23	22	21	20	19	18	16
MI42-2/2	883	278	605	196	260	84	7,5	10		48	46	44	42	41	39	35	31
MI42-3/3	1088	358	730	235	310	150	11	15		71	69	66	63	61	58	53	47
MI42-4/4	1168	438	730	235	310	162	15	20		95	92	88	84	81	78	71	62
MI42-5/5	1298	518	780	235	310	182	18,5	25		119	115	110	105	101	97	88	78
MI42-6/6	1370	598	807	235	310	225	22	30		143	138	132	125	122	116	106	93

Performance curve ISO9906:2012 Grade 3B

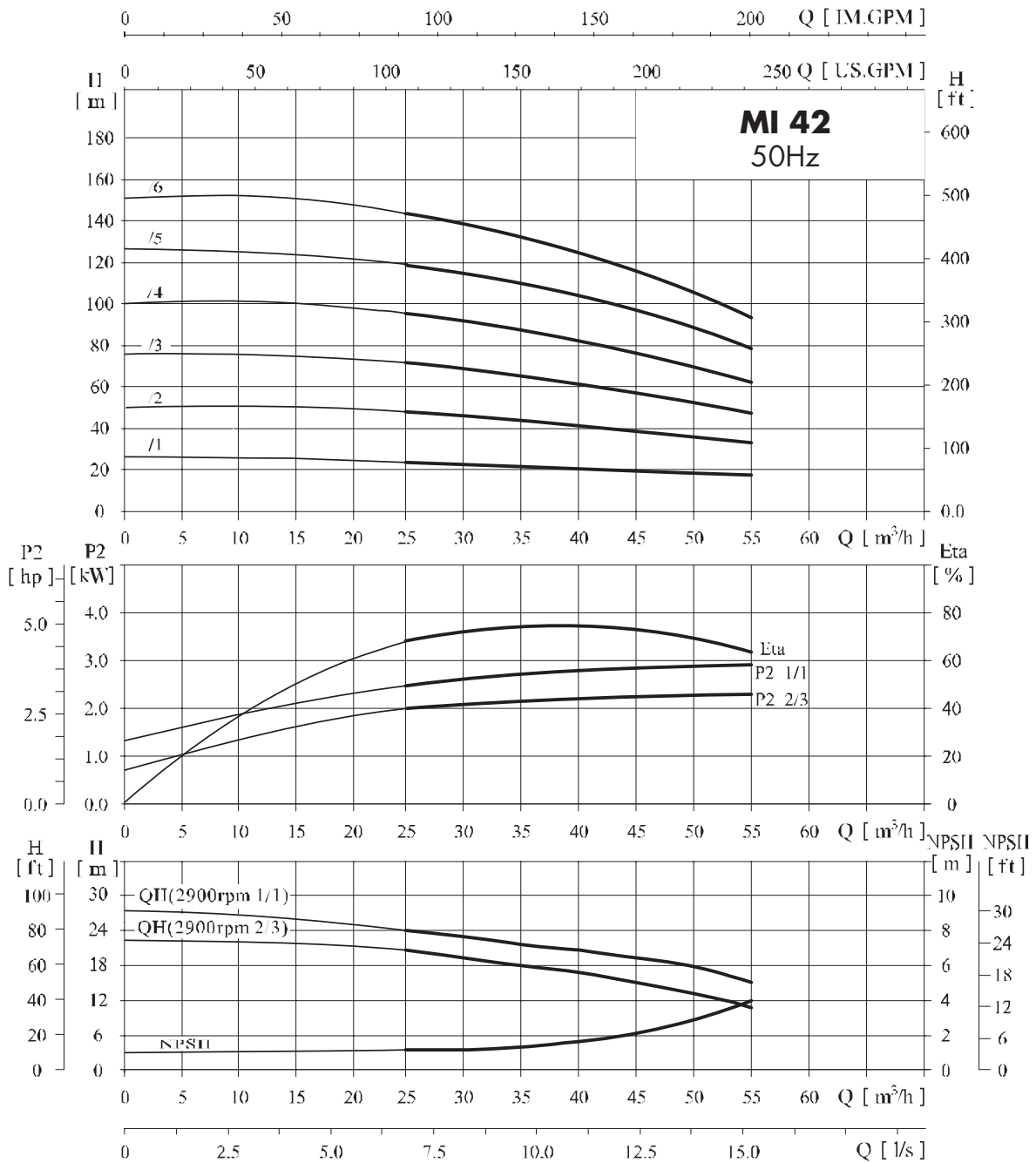

Vertical immersion pumps for coolants - 60 Hz



Vertical immersion pumps for coolants

Characteristics

MI are non-self priming multistage centrifugal pump. The motor shaft is directly connected with the pump shaft through coupling. According to the requirement, the pump can be equipped with a thermal protection device. In order to meet the requirement of installation depth of the water tank, it is possible to install empty chambers to changing length of the pump. Available lengths for different pump sizes are shown in the product table. All pumps are equipped with IE3 motors.

Application

MI is used for conveying cooling liquid, lubricating liquid and condensation water of machine tools, industrial cleaning equipment or other cases that application of immersed pump is suitable. MI is applicable to various temperature, flow and pressure ranges. In particular, it is applicable to lathes, grinding machines, processing centers, cooling devices, industrial cleaning equipment, filtering systems, etc.

For different uses, please consult our Technical Office.

Operation conditions

Clean non-explosive liquid without solid grains and fibers; can be used for conveying of water, cooling water solution and cutting lubricating liquid.

Liquid temperature:

- Normal temperature type: -15°C~+70°C
- Warm water type: -15°C~+120°C

Definition of model

MIF / MIX / MIN

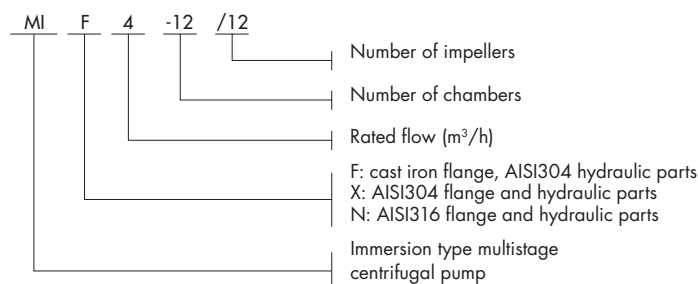

Performance

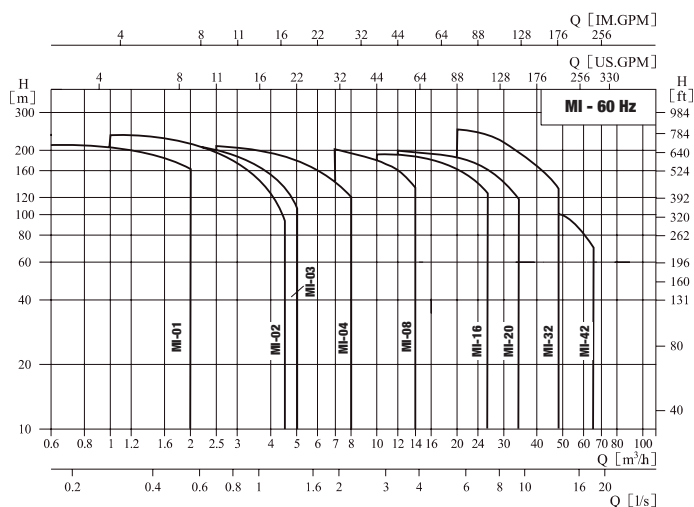

Range of products

Description	MI01	MI02	MI03	MI04	MI08	MI16	MI20	MI32	MI42
Nominal volumetric delivery (m ³ /h)	1	2	3	4	8	16	20	32	42
Nominal volumetric delivery (l/s)	0,28	0,56	0,83	1,1	2,2	4,4	5,6	8,9	11,7
Range of flow (m ³ /h)	0,6 - 2	1 - 45	1,5 - 5	2,5 - 8	7 - 14	10 - 26	12 - 34	20 - 48	30 - 65
Range of flow (l/s)	0,17-0,56	0,28 - 1,25	0,42 - 1,4	0,7-2,2	1,9 - 3,9	2,8 - 7,2	3,3 - 9,4	5,5 - 13,3	8,3 - 18
Max delivery head (bar)	22	23,5	23	21	20	20	20	18	10
Rated power (kW)	0,37 - 3	0,55 - 4	0,37- 4	0,75 - 5,5	1,5 - 11	4 - 18,5	4 - 18,5	4 - 22	7,5 - 18,5
Temperature (°C)	-15 ÷ +120								
Max efficiency (%)	44	46	54	57	62	66	69	73	75

Vertical immersion pumps

**Type MI 01
MI 02
MI 03
MI 04
MI 08
MI 16
MI 20**

MI 01-02-03-04-08-16-20

MIF

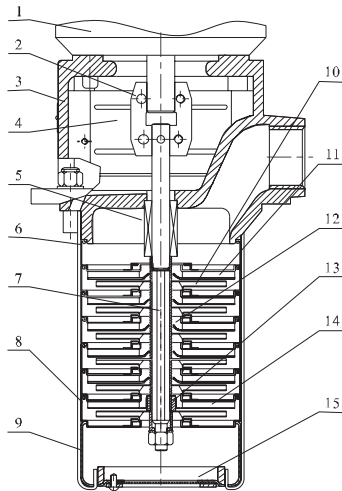

MIX - MIN

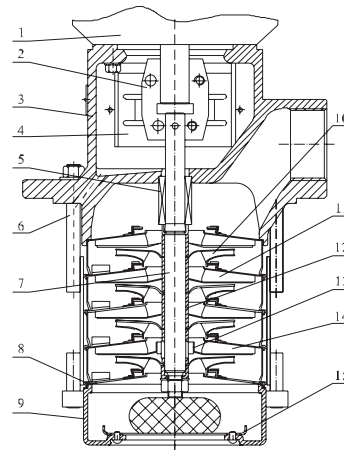

MI 01-02-03-04

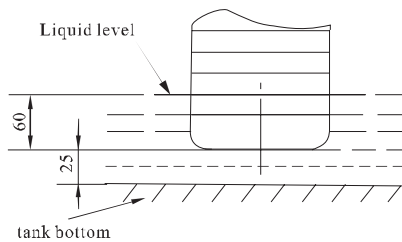

MI 08-16-20

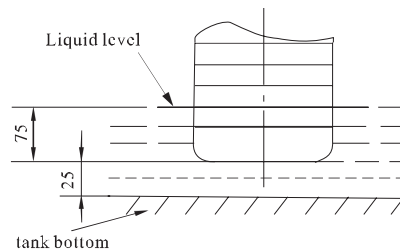

Spare parts nomenclature

Component	Material	AISI/ASTM
1 Motor		
2 Coupling	Carbon steel	
3 MIF Pump head	Cast iron	ASTM25B
3 MIX - MIN Pump head	Stainless steel	AISI304 / AISI316
4 Coupling guard	Stainless steel	AISI304 / AISI316
5 Mechanical seal		
6 Straps	Stainless steel	AISI304 / AISI316
7 Shaft	Stainless steel	AISI316
8 Inducer	Stainless steel	AISI304 / AISI316
9 Suction head	Stainless steel	AISI304 / AISI316
10 Impeller	Stainless steel	AISI304 / AISI316
11 Diffuser	Stainless steel	AISI304 / AISI316
12 Impeller sleeve	Stainless steel	AISI304 / AISI316
13 Bearing	Tungsten carbide	
14 Support diffuser	Stainless steel	AISI304 / AISI316
15 Strainer	Stainless steel	AISI304 / AISI316

MI 32-42

MIF - MIX - MIN

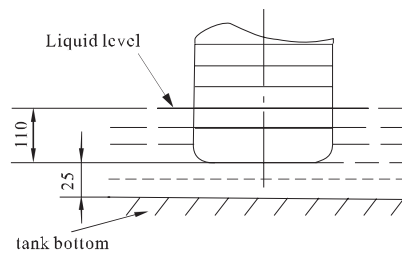
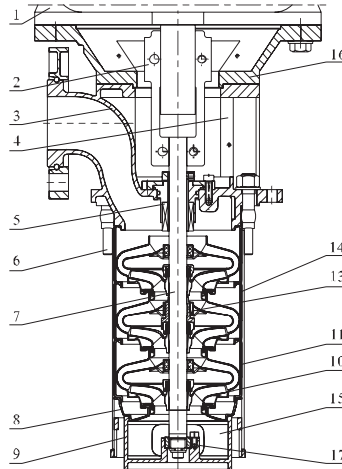

Spare parts nomenclature

Component	Material	AISI/ASTM
1 Motor		
2 Coupling	Carbon steel	
3 MIF Pump head	Cast iron	ASTM25B
3 MIX - MIN Pump head	Stainless steel	AISI304 / AISI316
4 Coupling guard	Stainless steel	AISI304 / AISI316
5 Mechanical seal		
6 Straps	Stainless steel	AISI304 / AISI316
7 Shaft	Stainless steel	AISI431 / AISI304 / AISI316
8 Inducer	Stainless steel	AISI304 / AISI316
9 Suction head	Stainless steel	AISI304 / AISI316
10 Impeller	Stainless steel	AISI304 / AISI316
11 Diffuser	Stainless steel	AISI304 / AISI316
12 Impeller sleeve	Stainless steel	AISI304 / AISI316
13 Bearing	Tungsten carbide	
14 Support diffuser	Stainless steel	AISI304 / AISI316
15 Strainer	Stainless steel	AISI304 / AISI316

Empty chambers availability

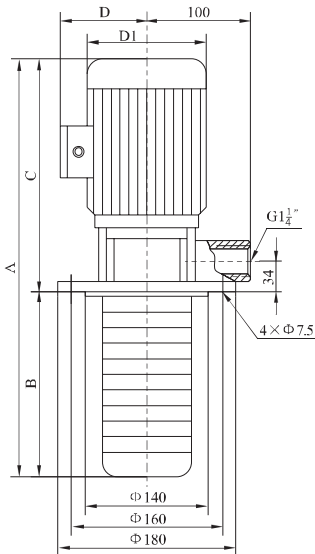

Number of chambers	Number of impellers																				L (mm)
	2	3	4	5	6	7	8	9	10	11	12	13	15	17	19	21	23	25			
2	●																			123	
3	○	●																		141	
4	○	○	●																	159	
5	○	○	○	●																177	
6	○	○	○	○	●															195	
7	○	○	○	○	○	●														213	
8	○	○	○	○	○	○	●													231	
9	○	○	○	○	○	○	○	●												249	
10	○	○	○	○	○	○	○	○	●											267	
11	○	○	○	○	○	○	○	○	○	●										285	
12	○	○	○	○	○	○	○	○	○	○	●									303	
13	○	○	○	○	○	○	○	○	○	○	○	●								321	
15	○	○	○	○	○	○	○	○	○	○	○	○	●							357	
17	○	○	○	○	○	○	○	○	○	○	○	○	○	●						393	
19	○	○	○	○	○	○	○	○	○	○	○	○	○	○	●					429	
21	○	○	○	○	○	○	○	○	○	○	○	○	○	○	○	●				465	
23	○	○	○	○	○	○	○	○	○	○	○	○	○	○	○	○	●			501	
25	○	○	○	○	○	○	○	○	○	○	○	○	○	○	○	○	○	●		537	
27	○	○	○	○	○	○	○	○	○	○	○	○	○	○	○	○	○	○	○	573	
30	○	○	○	○	○	○	○	○	○	○	○	○	○	○	○	○	○	○	○	627	
33	○	○	○	○	○	○	○	○	○	○	○	○	○	○	○	○	○	○	○	681	
36	○	○	○	○	○	○	○	○	○	○	○	○	○	○	○	○	○	○	○	735	
Motor (kW)	0,37		0,55		0,75		1,1		1,5		2,2		3								

Dimensions and performances

Model	Dimensions					Weight (Kg)	Motor		Q (m³/h)	H (m)							
	A	B	C	D	D1		(kW)	(hp)		0,6	0,8	1	1,2	1,4	1,6	1,8	2
MI01-2/2	430	123	307	112	141	15	0,37	0,5	H (m)	17,5	17	16,5	16	15,5	15	14	13
MI01-3/3	448	141	307	112	141	15	0,37	0,5		26,5	26	25	24	23	22	21	20
MI01-4/4	466	159	307	112	141	15	0,37	0,5		35	34	33	32	31	30	28	26
MI01-5/5	484	177	307	112	141	16	0,55	0,75		43	42	41	40	39	38	35	33
MI01-6/6	502	195	307	112	141	16	0,55	0,75		52	51	50	48	47	45	43	39
MI01-7/7	545	213	332	125	160	19	0,75	1		60	59	58	56	55	52	50	46
MI01-8/8	563	231	332	125	160	19	0,75	1		68	67	65	64	62	59	57	53
MI01-9/9	581	249	332	125	160	20	0,75	1		76	75	74	73	71	66	64	60
MI01-10/10	599	267	332	125	160	22	1,1	1,5		85	84	83	81	78	74	72	67
MI01-11/11	617	285	332	125	160	22	1,1	1,5		95	93	90	87	85	81	78	73
MI01-12/12	659	303	356	125	160	24	1,1	1,5		103	102	98	96	92	88	86	79
MI01-13/13	677	321	356	125	160	24	1,1	1,5		112	110	107	105	100	95	93	86
MI01-15/15	726	357	369	129	180	29	1,5	2		127	125	123	121	117	112	107	99
MI01-17/17	762	393	369	129	180	29	1,5	2		144	141	139	137	132	124	120	112
MI01-19/19	823	429	394	129	180	33	2,2	3		160	157	155	153	147	141	134	124
MI01-21/21	859	465	394	129	180	33	2,2	3		177	174	172	168	162	153	147	138
MI01-23/23	895	501	394	129	180	33	2,2	3		193	190	188	184	174	167	161	152
MI01-25/25	978	537	441	141	200	40	3	4		210	207	205	202	192	184	176	164

Performance curve ISO9906:2012 Grade 3B

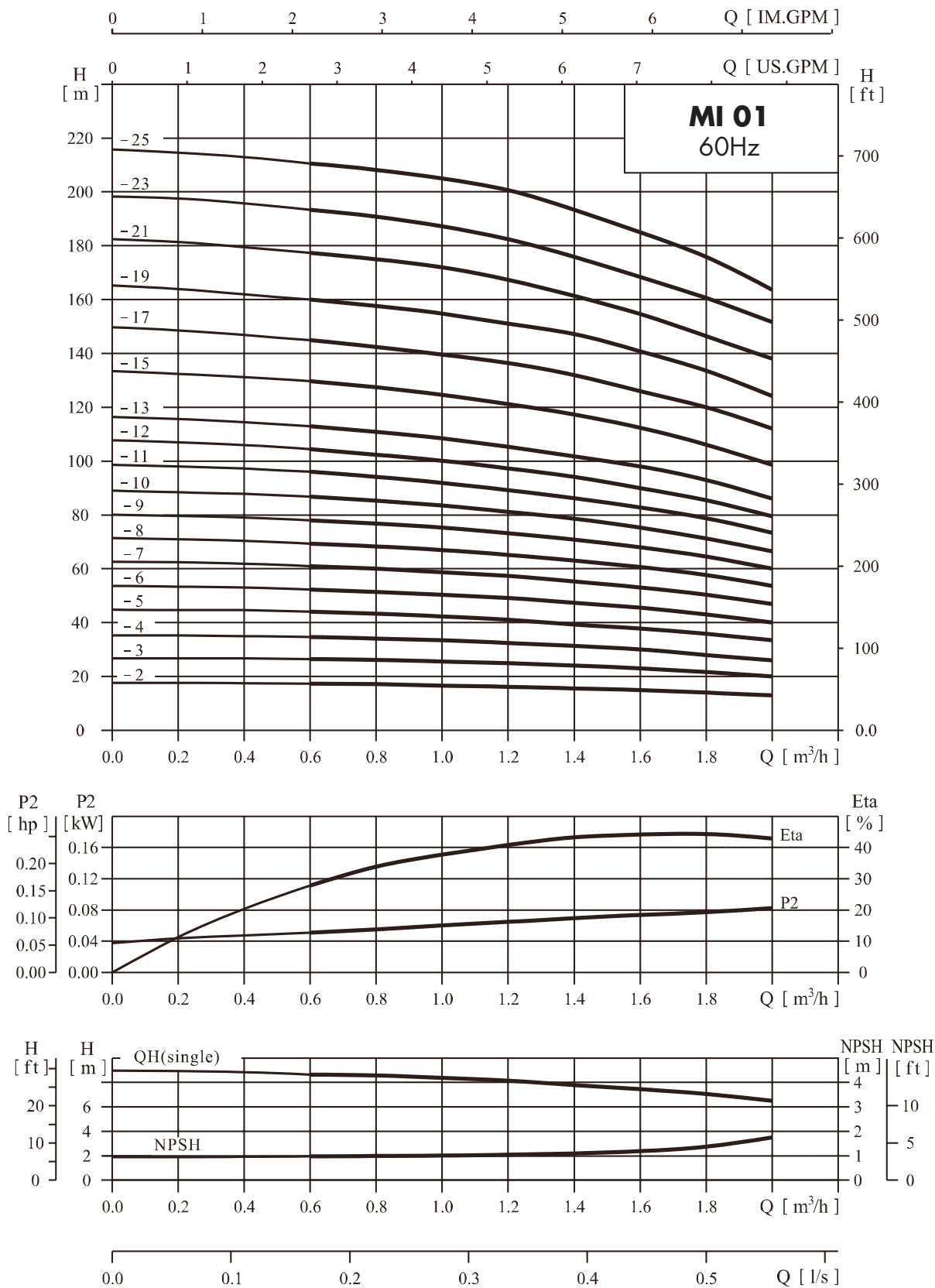

Empty chambers availability

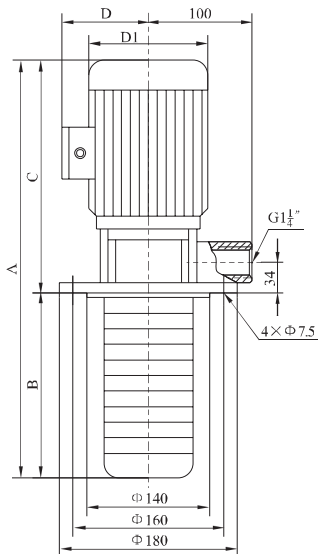

Number of chambers	Number of impellers										L (mm)	
	2	3	4	5	6	7	9	11	13	15		18
2	●											123
3	○	●										141
4	○	○	●									159
5	○	○	○	●								177
6	○	○	○	○	●							195
7	○	○	○	○	○	●						213
9	○	○	○	○	○	○	●					249
11	○	○	○	○	○	○	○	●				285
13	○	○	○	○	○	○	○	○	●			321
15	○	○	○	○	○	○	○	○	○	●		357
18	○	○	○	○	○	○	○	○	○	○	●	411
22	○	○	○	○	○	○	○	○	○	○	○	483
26	○	○	○	○	○	○	○	○	○	○	○	555
Motor (kW)	0,55	0,75	1,1		1,5		2,2	3		4		

Dimensions and performances

Model	Dimensions					Weight (Kg)	Motor		Q (m³/h)	H (m)							
	A	B	C	D	D1		(kW)	(hp)		1	1,5	2	2,5	3	3,5	4	4,5
MI02-2/2	430	123	307	112	141	15	0,55	0,75	H (m)	26	24	22	21	18	16	12	9
MI02-3/3	473	141	332	125	160	18	0,75	1		39	36	33	31	27	24	19	15
MI02-4/4	491	159	332	125	160	20	1,1	1,5		52	48	45	42	36	32	26	20
MI02-5/5	509	177	332	125	160	20	1,1	1,5		65	60	57	52	46	41	32	25
MI02-6/6	551	195	356	125	160	22	1,1	1,5		78	74	69	63	56	49	40	30
MI02-7/7	582	213	369	129	180	27	1,5	2		91	86	81	74	66	57	47	35
MI02-9/9	643	249	394	129	180	31	2,2	3		117	111	104	95	86	75	61	45
MI02-11/11	679	285	394	129	180	31	2,2	3		143	136	128	116	104	90	75	56
MI02-13/13	762	321	441	141	200	37	3	4		171	163	152	139	126	108	90	66
MI02-15/15	798	357	441	141	200	37	3	4		195	186	176	160	142	125	103	77
MI02-18/18	873	411	462	168	224	42	4	5,5		234	228	212	195	171	151	126	94

Performance curve ISO9906:2012 Grade 3B

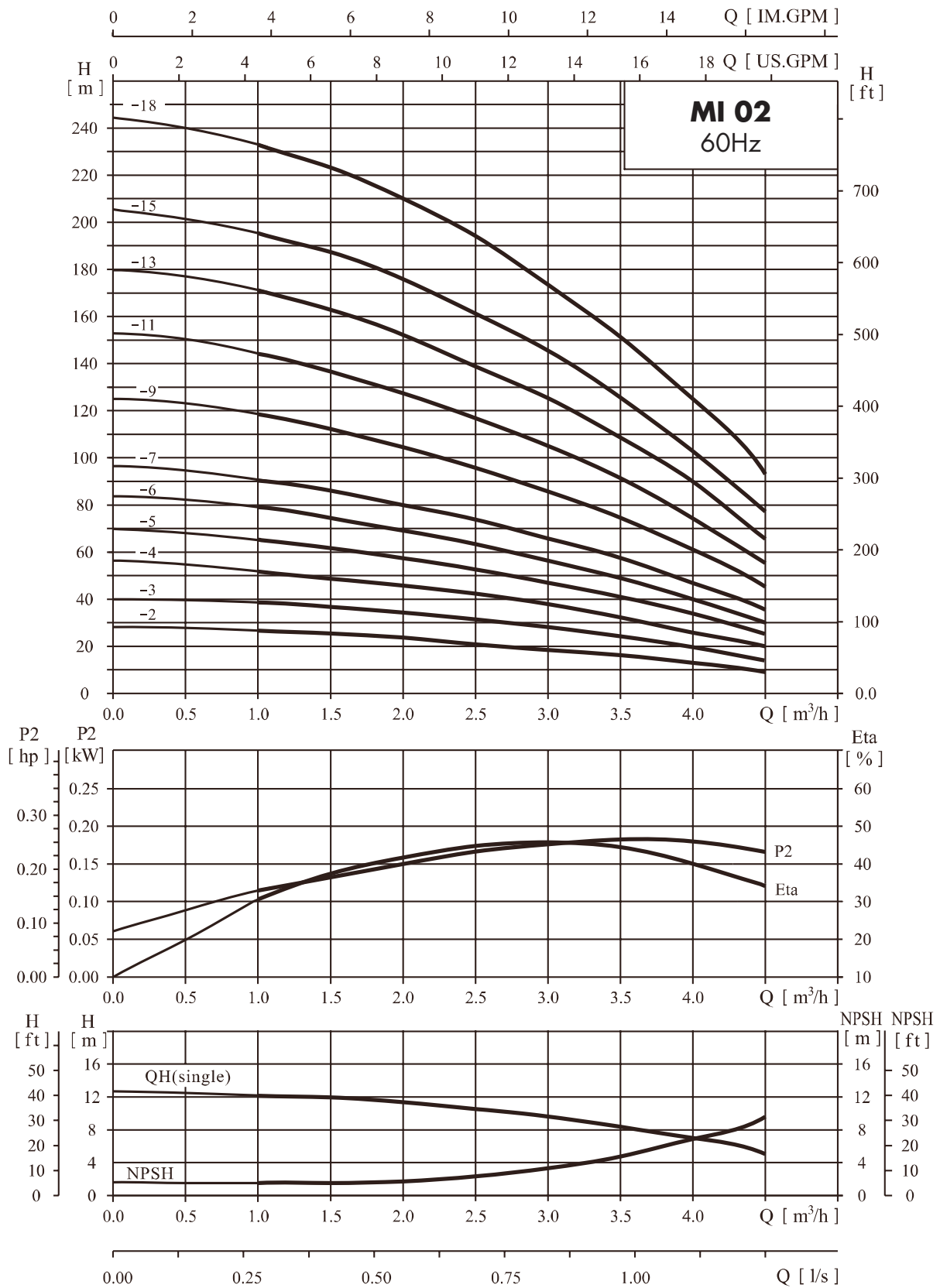

Empty chambers availability

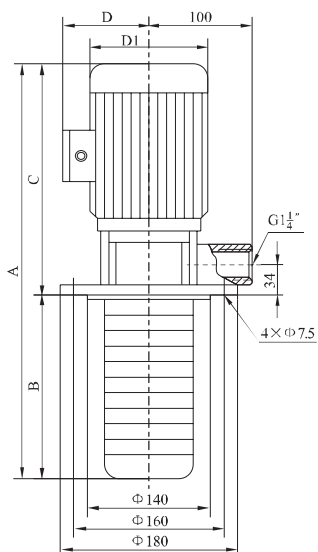

Number of chambers	Number of impellers															L (mm)			
	2	3	4	5	6	7	8	9	10	11	12	13	15	17	19		21	23	25
2	●																		123
3	○	●																	141
4	○	○	●																159
5	○	○	○	●															177
6	○	○	○	○	●														195
7	○	○	○	○	○	●													213
8	○	○	○	○	○	○	●												231
9	○	○	○	○	○	○	○	●											249
10	○	○	○	○	○	○	○	○	●										267
11	○	○	○	○	○	○	○	○	○	●									285
12	○	○	○	○	○	○	○	○	○	○	●								303
13	○	○	○	○	○	○	○	○	○	○	○	●							321
15	○	○	○	○	○	○	○	○	○	○	○	○	●						357
17	○	○	○	○	○	○	○	○	○	○	○	○	○	●					393
19	○	○	○	○	○	○	○	○	○	○	○	○	○	○	●				429
21	○	○	○	○	○	○	○	○	○	○	○	○	○	○	○	●			465
23	○	○	○	○	○	○	○	○	○	○	○	○	○	○	○	○	●		501
25	○	○	○	○	○	○	○	○	○	○	○	○	○	○	○	○	○	●	537
27	○	○	○	○	○	○	○	○	○	○	○	○	○	○	○	○	○	○	573
29	○	○	○	○	○	○	○	○	○	○	○	○	○	○	○	○	○	○	609
31	○	○	○	○	○	○	○	○	○	○	○	○	○	○	○	○	○	○	645
33	○	○	○	○	○	○	○	○	○	○	○	○	○	○	○	○	○	○	681
36	○	○	○	○	○	○	○	○	○	○	○	○	○	○	○	○	○	○	735
Motor (kW)	0,37	0,55	0,75	1,1			1,5			2,2			3			4			

Dimensions and performances

Model	Dimensions					Weight (Kg)	Motor		Q (m³/h)	H (m)							
	A	B	C	D	D1		(kW)	(hp)		1,5	2	2,5	3	3,5	4	4,5	5
MI03-2/2	430	123	307	112	141	15	0,37	0,5	H (m)	17,5	16	15	14	13	11	9	8
MI03-3/3	448	141	307	112	141	15	0,55	0,75		26,5	25	24	23	20	18	15	12
MI03-4/4	466	159	307	112	141	15	0,55	0,75		35	34	32	30	27	25	20	17
MI03-5/5	509	177	332	125	160	19	0,75	1		44	42	40	38	33	31	26	23
MI03-6/6	527	195	332	125	160	21	1,1	1,5		51	50	48	45	40	37	32	27
MI03-7/7	545	213	332	125	160	22	1,1	1,5		61	59	56	52	46	43	38	31
MI03-8/8	587	231	356	125	160	22	1,1	1,5		70	67	64	61	53	49	44	35
MI03-9/9	618	249	369	129	180	27	1,5	2		78	77	72	68	60	56	50	40
MI03-10/10	636	267	369	129	180	28	1,5	2		87	84	81	76	68	63	55	44
MI03-11/11	654	285	369	129	180	28	1,5	2		96	92	87	82	74	69	59	48
MI03-12/12	697	303	394	129	180	31	2,2	3		104	100	96	90	79	73	63	52
MI03-13/13	715	321	394	129	180	31	2,2	3		112	109	104	98	86	80	69	57
MI03-15/15	751	357	394	129	180	32	2,2	3		129	126	120	112	99	93	81	65
MI03-17/17	800	393	407	129	180	32	2,2	3		147	143	137	128	114	106	91	74
MI03-19/19	870	429	441	141	200	37	3	4		165	160	153	142	126	118	102	82
MI03-21/21	906	465	441	141	200	38	3	4		183	178	170	160	141	129	112	91
MI03-23/23	942	501	441	141	200	38	3	4		200	194	185	174	154	142	122	98
MI03-25/25	999	537	462	168	224	44	4	5,5		217	211	202	187	167	154	134	108

Performance curve ISO9906:2012 Grade 3B

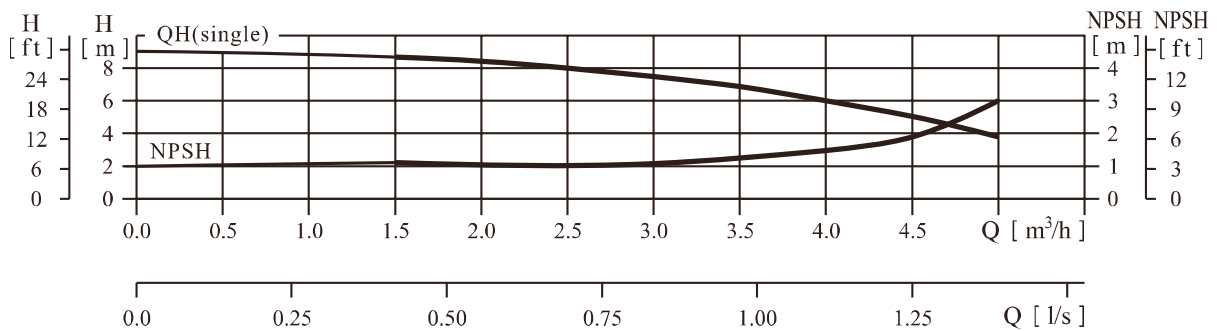
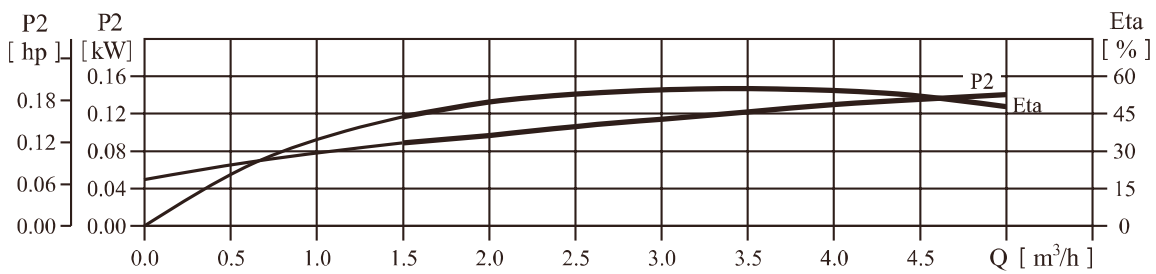
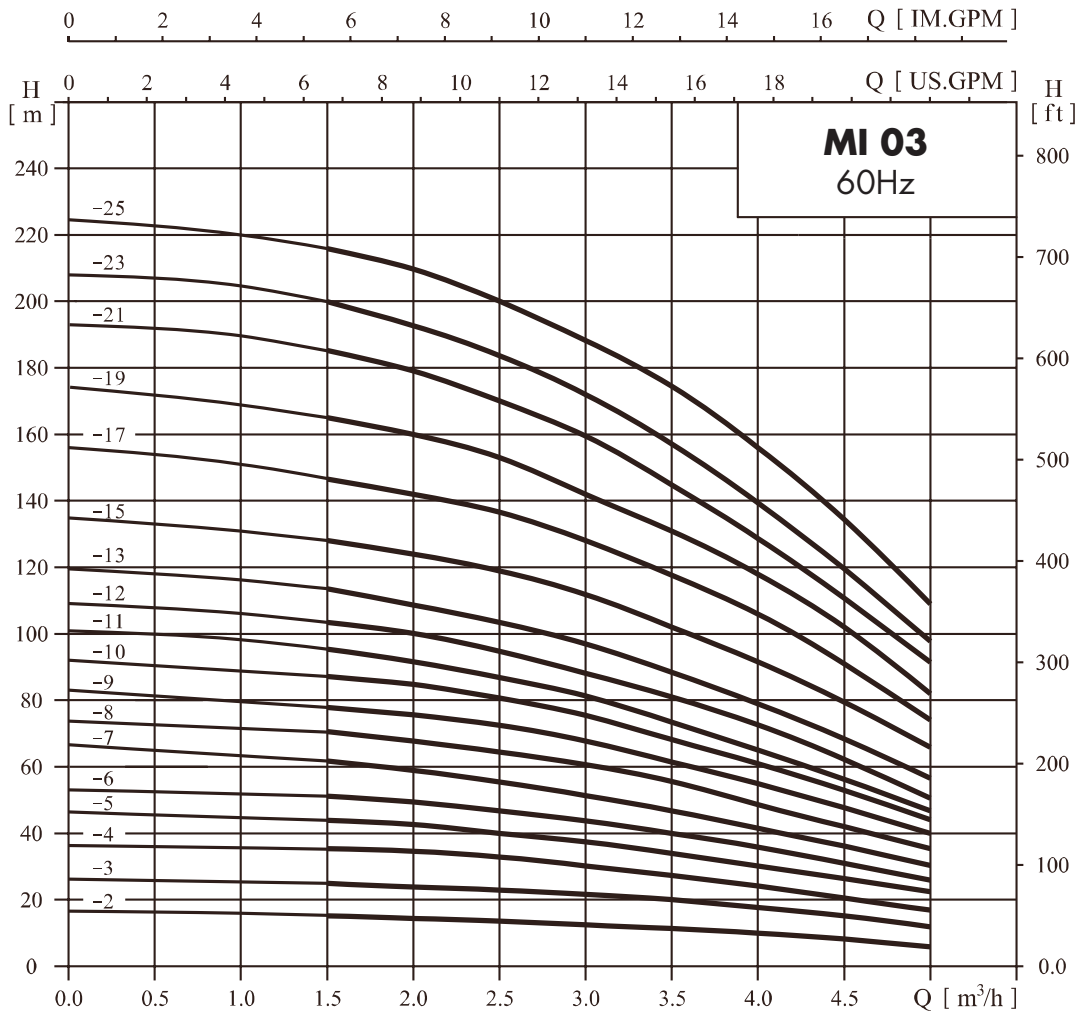

Empty chambers availability

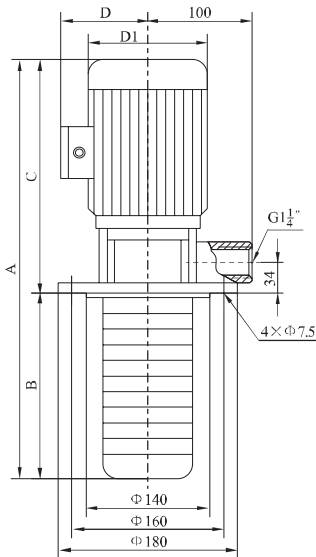

Number of chambers	Number of impellers											L (mm)	
	2	3	4	5	6	7	8	10	12	14	16		
2	●												148
3	○	●											175
4	○	○	●										202
5	○	○	○	●									229
6	○	○	○	○	●								256
7	○	○	○	○	○	●							283
8	○	○	○	○	○	○	●						310
10	○	○	○	○	○	○	○	●					364
12	○	○	○	○	○	○	○	○	●				418
14	○	○	○	○	○	○	○	○	○	●			472
16	○	○	○	○	○	○	○	○	○	○	●		526
19	○	○	○	○	○	○	○	○	○	○	○	○	607
22	○	○	○	○	○	○	○	○	○	○	○	○	688
Motor (kW)	0,75	1,1	1,5	2,2	3	4	5,5						

Dimensions and performances

Model	Dimensions				D1	Weight (Kg)	Motor		Q (m³/h)	H (m)						
	A	B	C	D			(kW)	(hp)		2,5	3	4	5	6	7	8
MI04-2/2	480	148	332	125	160	15	0,75	1	H (m)	26	25	23	21	19	16	14
MI04-3/3	507	175	332	125	160	18	1,1	1,5		39	38	36	32	28	24	21
MI04-4/4	571	202	369	129	180	23	1,5	2		52	50	48	44	38	35	31
MI04-5/5	623	229	394	129	180	27	2,2	3		65	62	60	55	49	44	39
MI04-6/6	650	256	394	129	180	27	2,2	3		78	75	72	67	59	54	47
MI04-7/7	724	283	441	141	200	33	3	4		92	88	84	78	69	62	55
MI04-8/8	751	310	441	141	200	33	3	4		104	100	95	90	79	72	63
MI04-10/10	826	364	462	168	224	38	4	5,5		130	125	120	113	102	90	80
MI04-12/12	880	418	462	168	224	38	4	5,5		156	150	145	136	122	109	96
MI04-14/14	1021	472	549	196	260	63	5,5	7,5		182	176	170	159	145	129	112
MI04-16/16	1075	526	549	196	260	63	5,5	7,5		207	201	196	183	165	146	128

Performance curve ISO9906:2012 Grade 3B

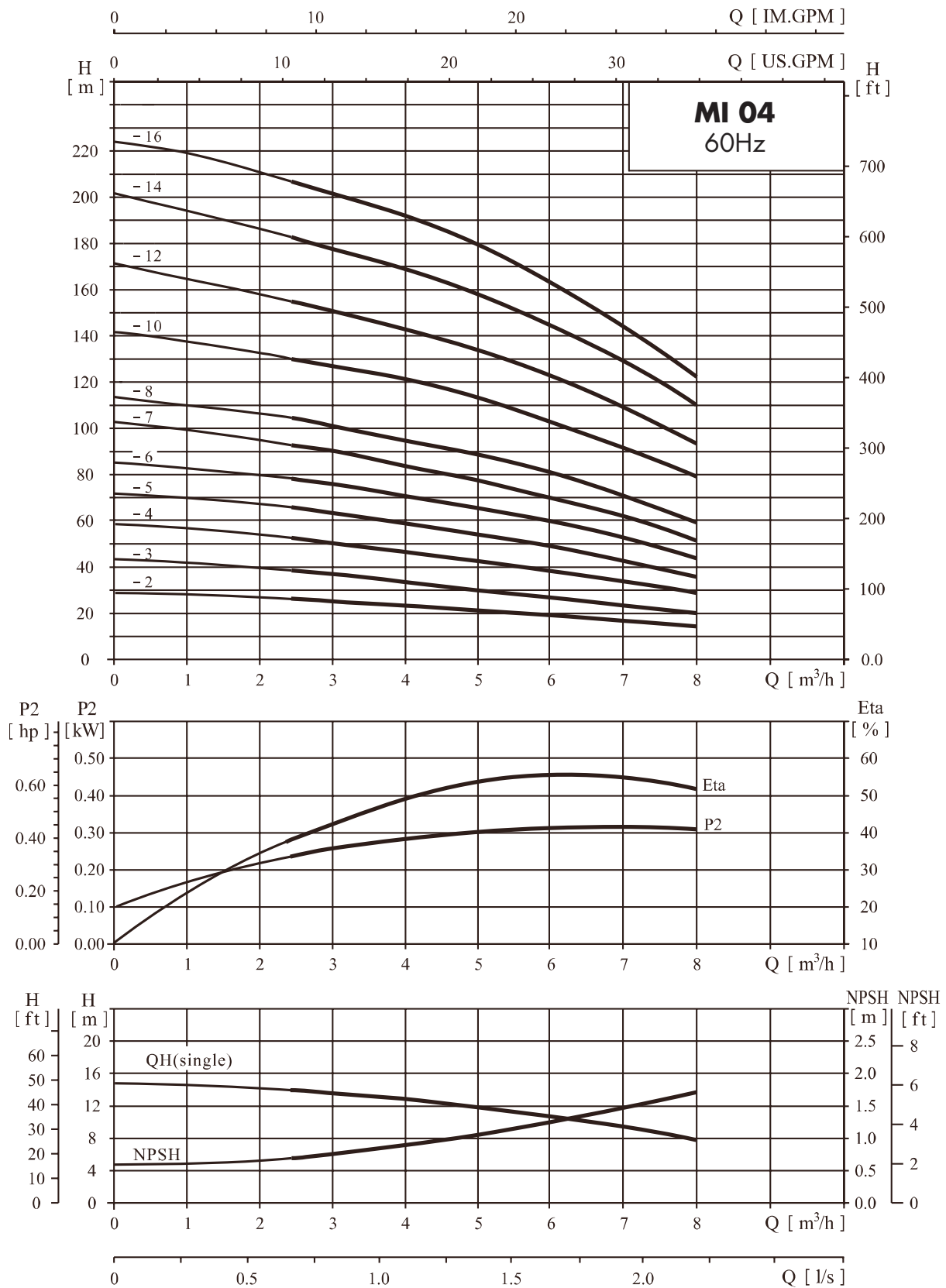

Empty chambers availability

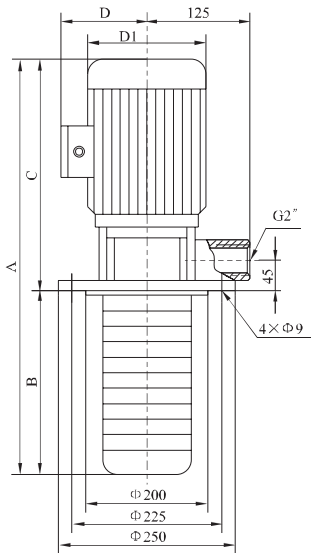

Number of chambers	Number of impellers										L (mm)
	2	3	4	5	6	8	10	12	14		
2	●										150
3	○	●									180
4	○	○	●								210
5	○	○	○	●							240
6	○	○	○	○	●						270
8	○	○	○	○	○	●					330
10	○	○	○	○	○	○	●				390
12	○	○	○	○	○	○	○	●			450
14	○	○	○	○	○	○	○	○	●		510
16	○	○	○	○	○	○	○	○	○	○	570
18	○	○	○	○	○	○	○	○	○	○	630
20	○	○	○	○	○	○	○	○	○	○	690
Motor (kW)	1,5	2,2	3	4	5,5	7,5	11				

Dimensions and performances

Model	Dimensions					Weight (Kg)	Motor		Q (m ³ /h)	H (m)							
	A	B	C	D	D1		(kW)	(hp)		7	8	9	10	11	12	13	14
MI08-2/2	527	150	377	129	180	32	1,5	2	H (m)	27	26	25	24	23	22	20	18
MI08-3/3	582	180	402	129	180	37	2,2	3		41	40	38	37	35	33	30	28
MI08-4/4	657	210	447	141	200	45	3	4		55	54	52	50	47	45	41	38
MI08-5/5	687	240	447	141	200	47	3	4		70	68	65	63	59	56	52	47
MI08-6/6	738	270	468	168	224	52	4	5,5		85	82	78	76	72	68	62	57
MI08-8/8	885	330	555	196	260	72	5,5	7,5		115	110	105	101	97	91	84	75
MI08-10/10	947	390	557	196	260	78	7,5	10		145	140	132	126	122	115	105	95
MI08-12/12	1007	450	557	196	260	80	7,5	10		173	167	160	152	147	132	125	115
MI08-14/14	1175	510	665	235	310	135	11	15		202	195	188	179	174	163	147	135

Performance curve ISO9906:2012 Grade 3B

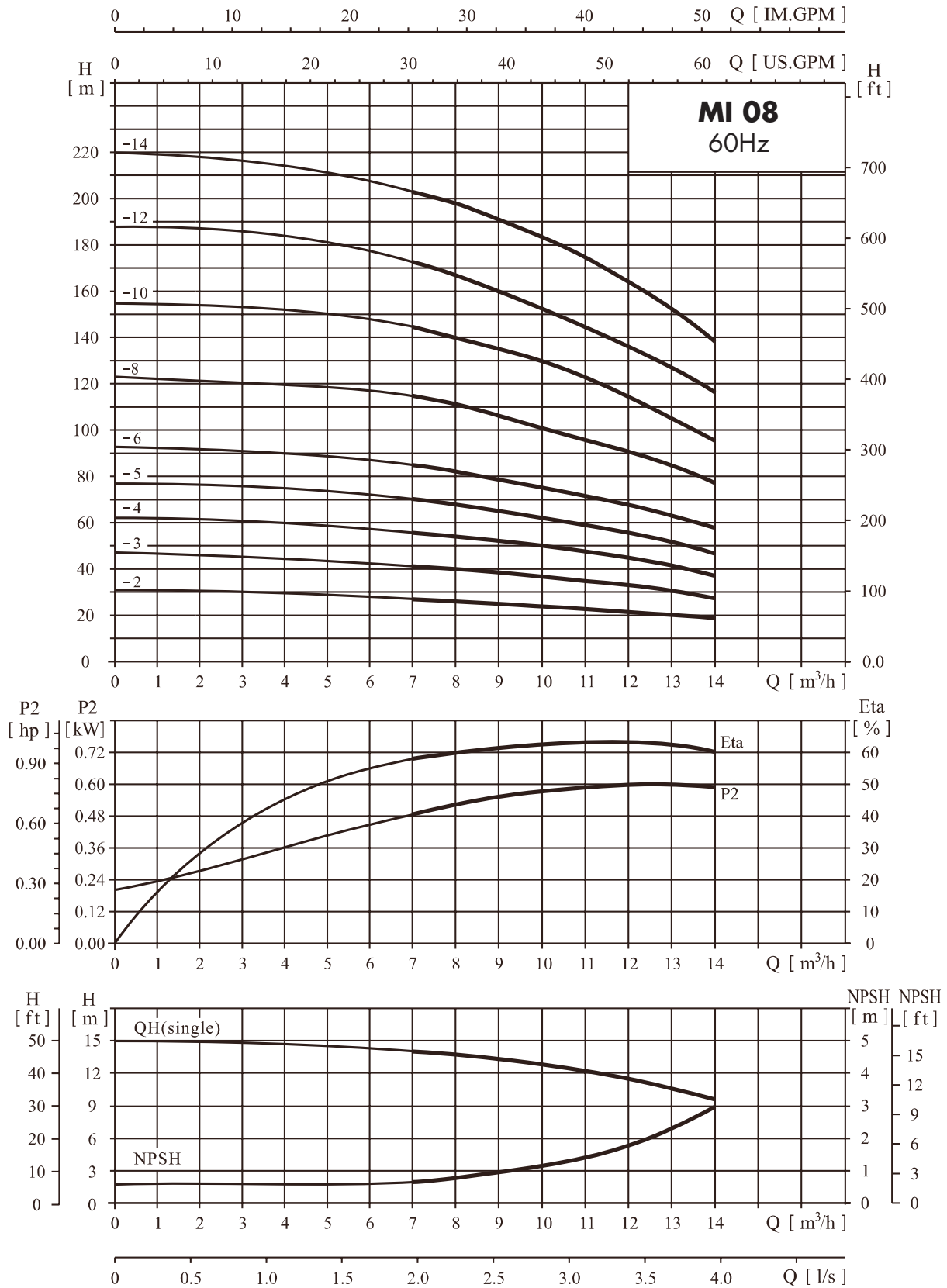

Empty chambers availability

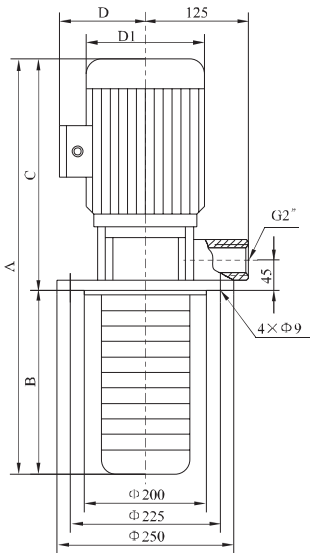

Number of chambers	Number of impellers										L (mm)
	2	3	4	5	6	7	8	10			
2	●										180
3	○	●									225
4	○	○	●								270
5	○	○	○	●							315
6	○	○	○	○	●						360
7	○	○	○	○	○	●					405
8	○	○	○	○	○	○	●				450
10	○	○	○	○	○	○	○	●			540
12	○	○	○	○	○	○	○	○	○		630
14	○	○	○	○	○	○	○	○	○		720
16	○	○	○	○	○	○	○	○	○		810
Motor (kW)	4	5,5	7,5	11	15	18,5					

Dimensions and performances

Model	Dimensions					Weight (Kg)	Motor		Q (m³/h)	H (m)								
	A	B	C	D	D1		(kW)	(hp)		10	12	14	16	18	20	22	24	26
MI16-2/2	648	180	468	168	224	50	4	5,5	H (m)	38	37	36	35	34	32	30	27	24
MI16-3/3	780	225	555	196	260	65	5,5	7,5		57	56	55	54	51	48	45	40	36
MI16-4/4	827	270	557	196	260	75	7,5	10		76	75	73	72	68	64	60	54	49
MI16-5/5	980	315	665	235	310	130	11	15		96	94	92	90	85	80	75	68	62
MI16-6/6	1025	360	665	235	310	132	11	15		115	113	111	108	102	96	91	82	75
MI16-7/7	1070	405	665	235	310	140	15	20		135	132	129	126	119	113	106	96	88
MI16-8/8	1115	450	665	235	310	140	15	20		155	152	148	144	137	130	122	111	101
MI16-10/10	1282	540	742	235	310	150	18,5	25		197	192	187	181	174	165	153	139	127

Performance curve ISO9906:2012 Grade 3B

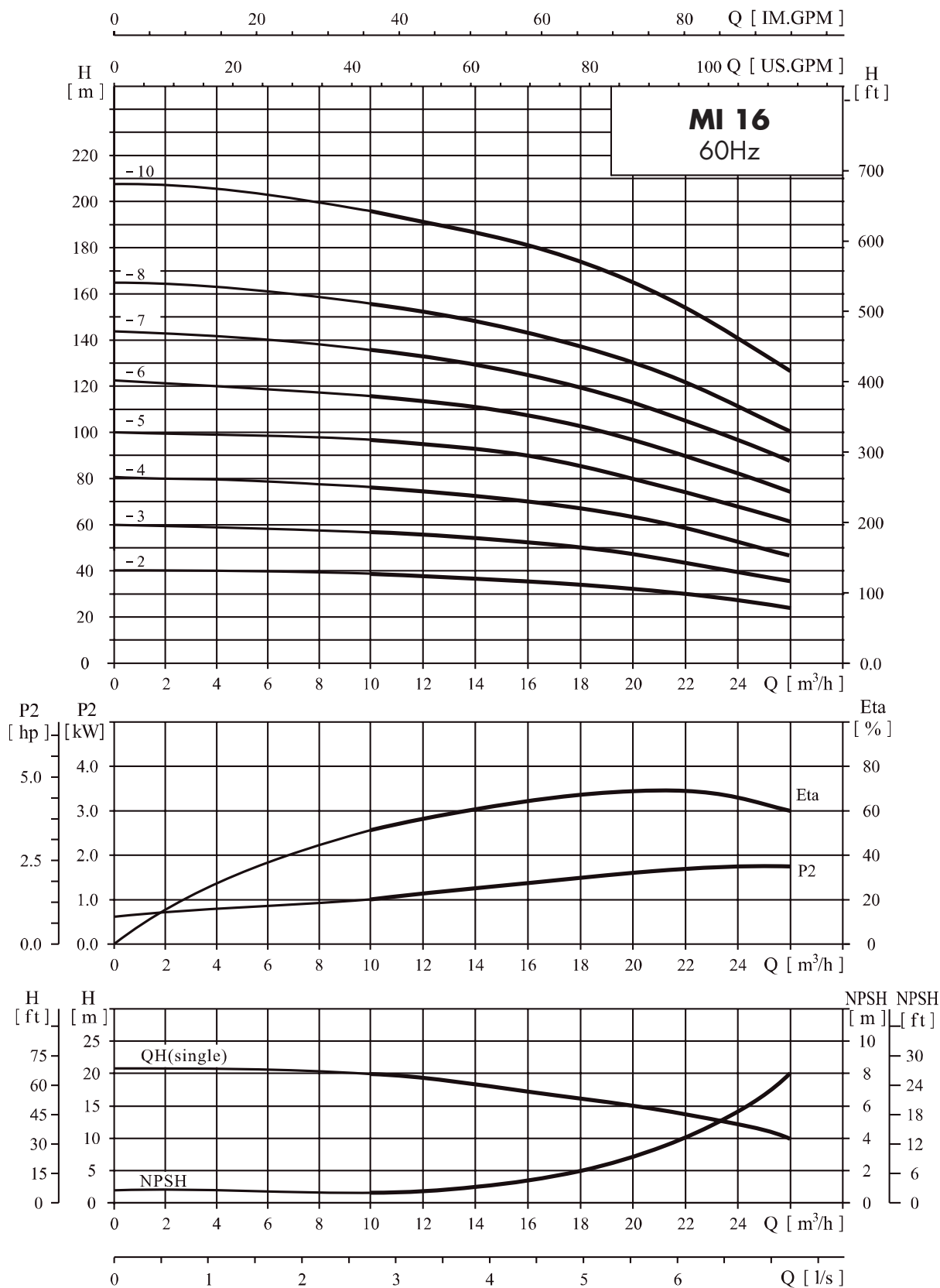

Empty chambers availability

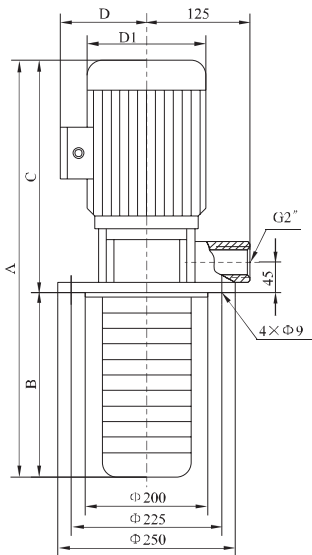

Number of chambers	Number of impellers										L (mm)
	2	3	4	5	6	7	8	10			
2	●										180
3	○	●									225
4	○	○	●								270
5	○	○	○	●							315
6	○	○	○	○	●						360
7	○	○	○	○	○	●					405
8	○	○	○	○	○	○	●				450
10	○	○	○	○	○	○	○	●			540
12	○	○	○	○	○	○	○	○	○		630
14	○	○	○	○	○	○	○	○	○		720
17	○	○	○	○	○	○	○	○	○		855
Motor (kW)	4	5,5	7,5	11	15	18,5					

Dimensions and performances

Model	Dimensions					Weight (Kg)	Motor		Q (m³/h)	H (m)						
	A	B	C	D	D1		(kW)	(hp)		12	16	20	24	28	32	34
MI20-2/2	648	180	468	168	224	50	4	5,5	H (m)	38	37	35	32	29	24	21
MI20-3/3	782	225	557	196	260	65	5,5	7,5		58	56	53	50	45	38	33
MI20-4/4	855	270	585	196	260	75	7,5	10		78	75	72	67	60	51	45
MI20-5/5	980	315	665	235	310	130	11	15		98	94	90	85	75	64	57
MI20-6/6	1025	360	665	235	310	132	11	15		118	113	108	102	91	77	70
MI20-7/7	1070	405	665	235	310	140	15	20		138	133	127	119	107	91	83
MI20-8/8	1148	450	698	235	310	140	15	20		158	153	146	137	123	105	96
MI20-10/10	1282	540	742	235	310	150	18,5	25		198	193	185	172	155	133	122

Performance curve ISO9906:2012 Grade 3B

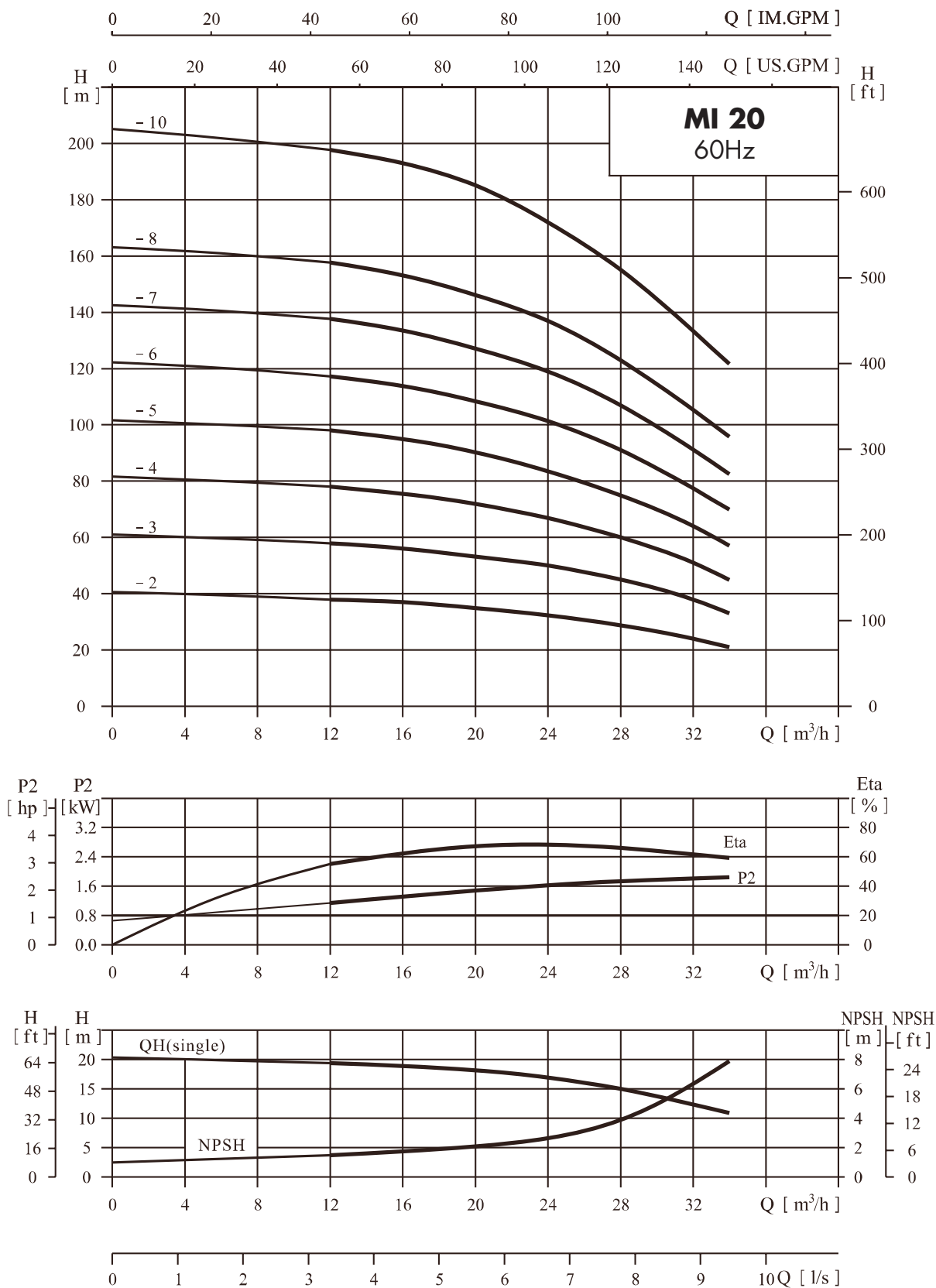

Empty chambers availability

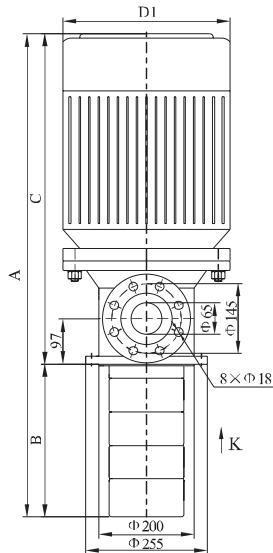

Number of chambers	Number of impellers							L (mm)
	1	2	3	4	5	6	7	
1	●							186
2	○	●						256
3	○	○	●					326
4	○	○	○	●				396
5	○	○	○	○	●			466
6	○	○	○	○	○	●		536
7	○	○	○	○	○	○	●	606
8	○	○	○	○	○	○	○	676
9	○	○	○	○	○	○	○	746
10	○	○	○	○	○	○	○	816
11	○	○	○	○	○	○	○	886
12	○	○	○	○	○	○	○	956
13	○	○	○	○	○	○	○	1026
14	○	○	○	○	○	○	○	1096
Motor (kW)	4	7,5	11	15	18,5	22		

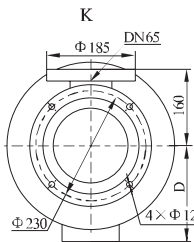

Dimensions and performances

Model	Dimensions					Weight (Kg)	Motor		Q (m³/h)	H (m)							
	A	B	C	D	D1		(kW)	(hp)		20	24	28	32	36	40	44	48
MI32-1/1	670	186	484	168	224	75	4	5,5	H (m)	26	25	24	23	21	19	17	14
MI32-2/2	819	256	563	196	260	95	7,5	10		52	50	48	45	41	37	33	27
MI32-3/3	997	326	671	235	310	150	11	15		78	75	71	67	62	56	50	40
MI32-4/4	1067	396	671	235	310	185	15	20		104	101	96	91	83	75	66	55
MI32-5/5	1226	466	760	235	310	215	18,5	25		130	125	119	112	104	94	83	69
MI32-6/6	1296	536	760	235	310	225	18,5	25		155	150	144	136	126	114	100	81
MI32-7/7	1366	606	793	235	310	260	22	30		182	176	168	159	148	133	118	97

Performance curve ISO9906:2012 Grade 3B

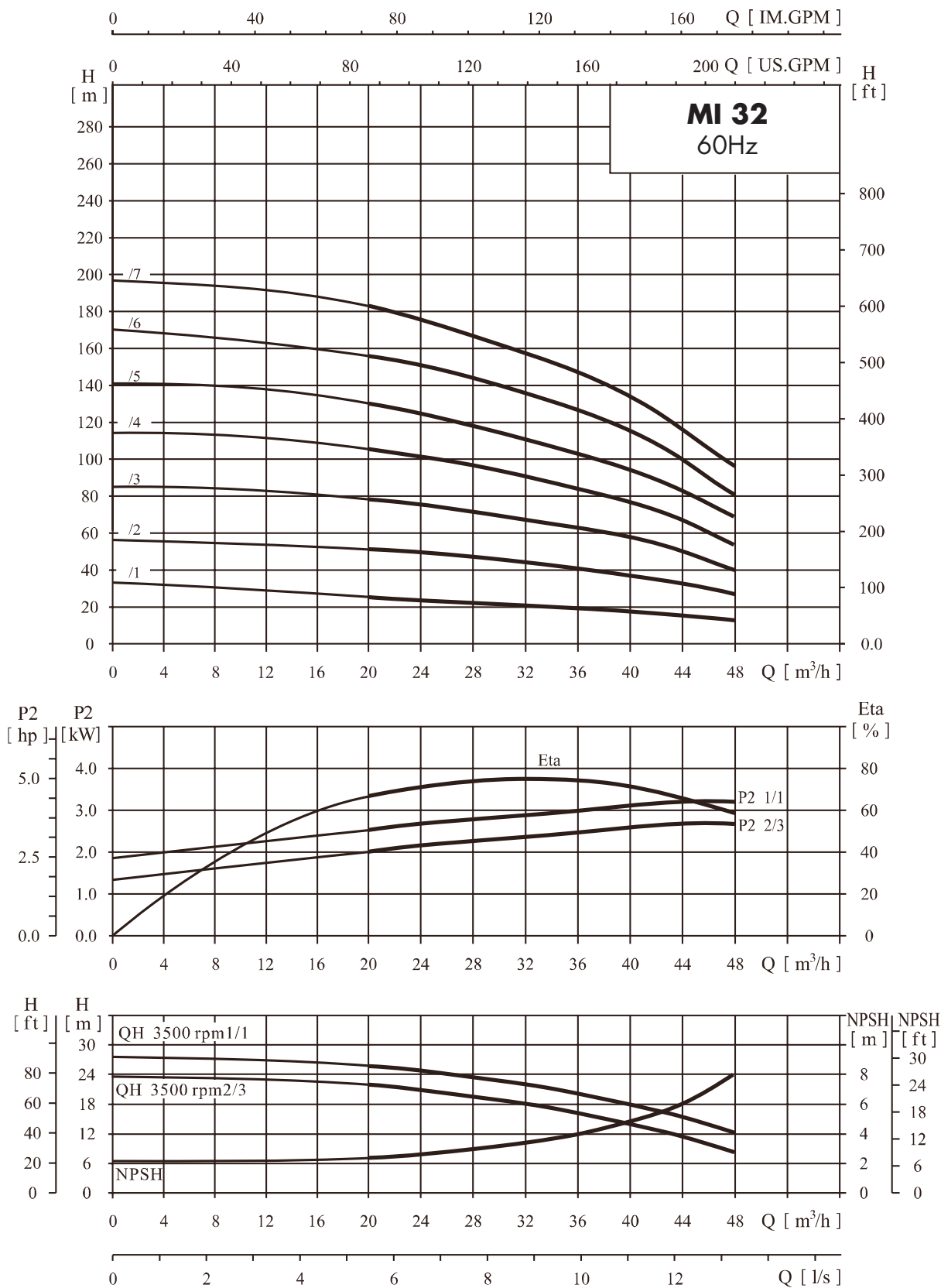

Empty chambers availability

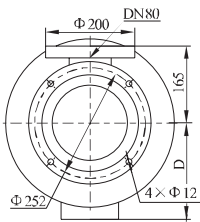
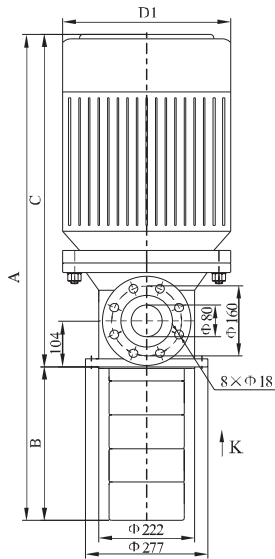

Number of chambers	Number of impellers			L (mm)
	1	2	3	
1	●			198
2	○	●		278
3	○	○	●	358
4	○	○	○	438
5	○	○	○	518
6	○	○	○	598
7	○	○	○	678
8	○	○	○	758
9	○	○	○	838
10	○	○	○	918
11	○	○	○	998
12	○	○	○	1078
13	○	○	○	1158
Motor (kW)	7,5	15	18,5	

Dimensions and performances

Model	Dimensions				Weight (Kg)	Motor		Q (m³/h)	H (m)								
	A	B	C	D		D1	(kW)		(hp)	30	35	40	42	45	50	55	60
MI42-1/1	775	198	577	196	260	83	7,5	10	34	33	32	31,5	30	29	27	25	22
MI42-2/2	963	278	685	235	310	162	15	20	69	67	65	63	61	59	55	50	44
MI42-3/3	1132	358	774	235	310	175	18,5	25	102	100	97	95	92	88	82	76	68

Performance curve ISO9906:2012 Grade 3B

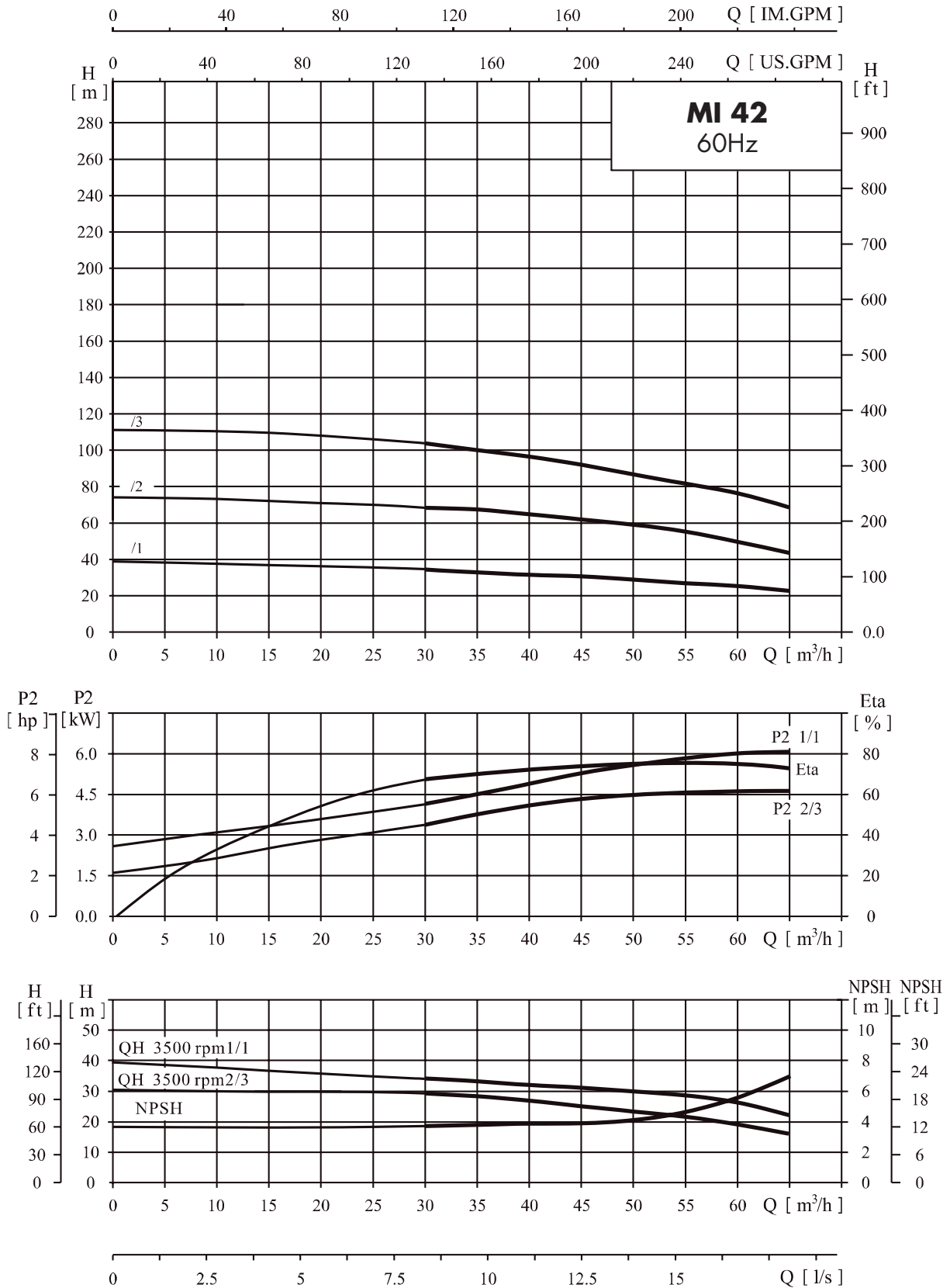

Lined writing area with horizontal lines.

It is forbidden to reproduce any part of this document in any form without the explicit written consent of SACEMI-GAMAR S.r.l.

The data in this catalogue are indicative and non-binding. SACEMI-GAMAR S.r.l. reserves the right to modify the indications at any time without notice, according to the technical development of the product.
This catalogue supersedes and replaces all previous ones.



Via A. Pacinotti 2
30020 Noventa di Piave (VE) Italy
T +39 0421 307389
F +39 0421 65428
info@sacemi.com
www.sacemigamar.com

