

8" REWINDABLE PERMANENT MAGNET MOTOR

BENEFITS & FEATURES

- Motors for operation with Variable frequency drive (VFD)
- 8" double flange NEMA mounting design
- High efficiency electrical design for low operation costs
- SandFighter™ sealing system with SIC mechanical seal and sand slinger
- Factory filled with Franklin's FES93 motor fill solution
- Drinking water approvals
- Stainless steel splined shaft
- Liquid lubricated radial bearings and High capacity Kingsbury type 45 kN thrust bearing for 100 % maintenance free operation
- Pressure-equalizing diaphragm, spring pre-loaded



STANDARD SPECIFICATION

- Ratings: 75 / 100 / 130 kW (100 Hz - 3000 rpm, 120 Hz - 3600 rpm)
- Max. storage temperature - 15 °C to + 60 °C
- Standard motor with PE2/PA winding insulation
- Nominal ambient temperature: 30 °C with 0.5 m/s cooling flow
- System Supply Voltage: 400 V (100 Hz) / 460 V (120 Hz)
- Voltage Tolerance: $\pm 10\% U_N$
- Protection IP68
- Standard Motor: WW- Water well Design (Stator 304SS / Castings - CI Powder coated)
- Motor protection: DIN 61947-4-1
- Frequency of starts: 10 starts/ hour (with min. 3 minutes resting time), equally distributed
- DOL-start
- All motors with factory installed leads, motor lead length: 6 m
- Motors installation orientation: Vertical / horizontal (shaft end heightened)
- Rotation counter clock wise facing shaft end (rotation reversible)

OPTIONS

- Higher-graded materials: 316SS, 904L
- Special voltages
- Retrofittable PT 100 temperature sensor (VFD PT100 Plug-in card necessary, order no. 308 170 202)
- Special lead lengths



3~ DOL MODEL NUMBERS 400 V / 100 HZ**

P_N [kW]	400V / 100 Hz WW * Motor model number	400V / 100 Hz 316SS Motor model number	400V / 100 Hz 904L Motor model number
75	263 014 5311	263 014 6311	263 014 7311
100	263 016 5311	263 016 6311	263 016 7311
130	263 018 5311	263 018 6311	263 018 7311

* WW (Water well)- Stator 304SS / Castings - CI Powder coated (see page material description in the catalog)

** PM motors are to be operated by Variable frequency drive (VFD)



8" REWINDABLE PERMANENT MAGNET MOTOR

EFFICIENCY CURVE AT 3000 RPM

efficiency [%] Motor η 400 V / 100 Hz [%] = f (P2 [kW])

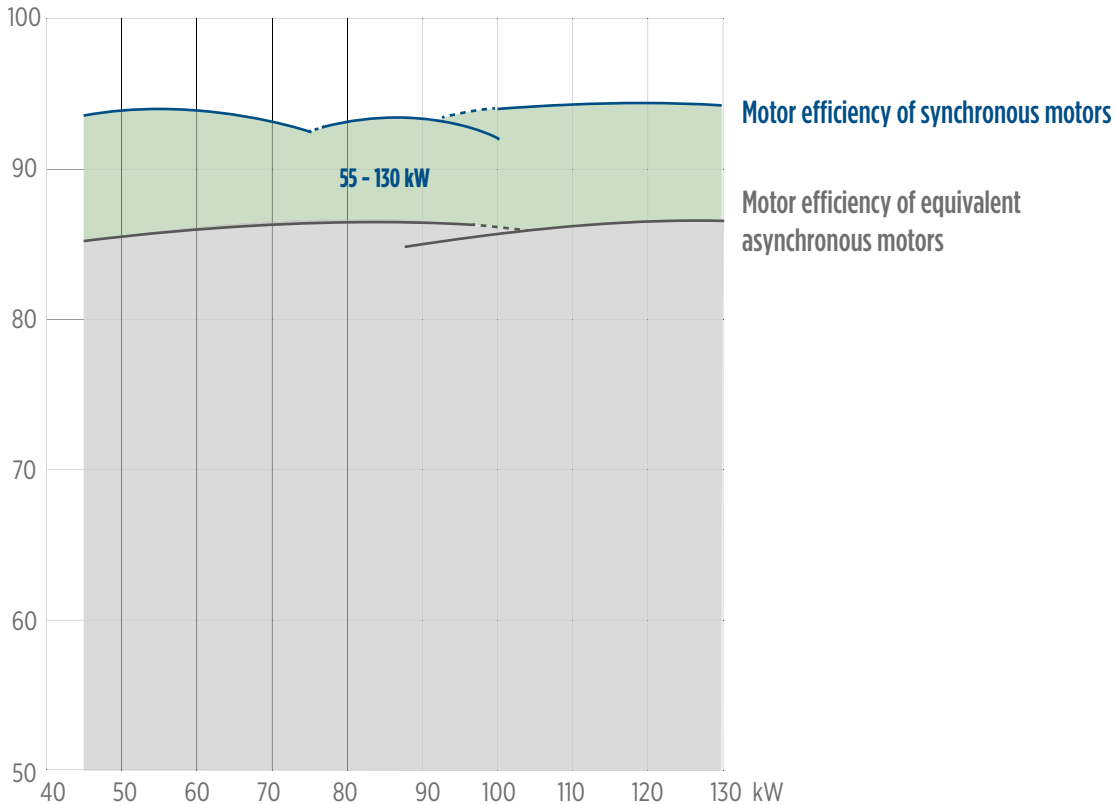

MOTOR PERFORMANCE DATA 400 V / 100 HZ

motor model no.	P_N [kW]	Thrust F [kN]	n_N [min ⁻¹]	I_N [A]	I_A/I_N^* [A]	η [%]	cos phi	T_N [Nm]	T_A/T_N^* [Nm]
263 014 xxxx	45	45	3000	74	1	93.3	0.96	143	1
	55	45	3000	91	1	93.3	0.96	175	1
	67	45	3000	112	1	93.0	0.96	213	1
	75	45	3000	128	1	92.5	0.96	239	1
263 016 xxxx	75	45	3000	129	1	93.5	0.95	239	1
	83	45	3000	143	1	93.3	0.95	264	1
	93	45	3000	162	1	93.0	0.95	296	1
	100	45	3000	178	1	92.7	0.95	319	1
263 018 xxxx	75	45	3000	125	1	93.8	0.97	239	1
	93	45	3000	153	1	93.7	0.97	296	1
	110	45	3000	186	1	93.3	0.97	350	1
	130	45	3000	225	1	92.6	0.96	414	1

Performance data are based on measurements with Franklin Electric original equipment.
 *Since this is an integrated system (motor plus electronics) these figures relate to VFD input.

8" REWINDABLE PERMANENT MAGNET MOTOR

MOTOR PERFORMANCE DATA 500 V / 100 HZ

motor model no.	P_N [kW]	Thrust F [kN]	n_N [min ⁻¹]	I_N [A]	I_A/I_N^* [A]	η [%]	cos phi	T_N [Nm]	T_A/T_N^* [Nm]
263 024 xxxx	45	45	3000	60	1	93.2	0.95	143	1
	55	45	3000	74	1	93.2	0.95	175	1
	67	45	3000	91	1	93.0	0.95	213	1
	75	45	3000	103	1	92.5	0.95	239	1
263 026 xxxx	75	45	3000	105	1	93.5	0.94	239	1
	83	45	3000	116	1	93.3	0.94	264	1
	93	45	3000	131	1	93.2	0.94	296	1
	100	45	3000	143	1	92.9	0.94	319	1
263 028 xxxx	75	45	3000	102	1	93.8	0.96	239	1
	93	45	3000	124	1	93.7	0.96	296	1
	110	45	3000	151	1	93.3	0.96	350	1
	130	45	3000	183	1	92.6	0.96	414	1

Performance data are based on measurements with Franklin Electric original equipment.
*Since this is an integrated system (motor plus electronics) these figures relate to VFD input.

MOTOR LEADS 400 V* DOL

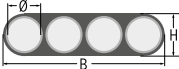
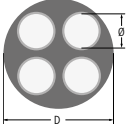
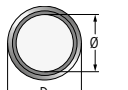
lead	kW	\emptyset [mm ²]	B / H [mm]		length [m]	Qty.	lead model no.	lead seal kit WW/316 model no.	Lead seal kit 904L model no.
	75	4G16	B	38,0	6	1	308 710 108	308 660 618	308 660 620
H			12,8						
	100	4G25	D	32	6	1	308 710 140	308 660 633	308 660 634
	130	3RD 1X35 + Ground lead 1x35	D	15,3	6	1	308 710 151	308 660 641	308 660 642

Lead opening seal kit		qty.	model no.
8" Rew	WW / 316SS	1	308 660 617
	904L	1	308 660 625

Leads are designed for submerged operation. For air operation please consult Franklin Electric.

8" REWINDABLE PERMANENT MAGNET MOTOR

MOTOR DROP LEADS 400 V / 100 HZ - 460 V / 120 HZ

P _N [kW]	cable size [mm ²], copper wire - 90 °C rated insulation											
	16	25	35	50	70	95	120	150	185	240	300	400
45	65	100	140	200	280	370	460					
55		85	120	170	230	300	370	450				
67			90	130	180	240	300	360	420			
75			80	115	160	200	260	310	370	460		
83				100	140	190	235	285	340	420		
93					115	160	200	240	290	350	410	
110					100	140	170	210	250	305	360	440
130						115	145	175	210	260	305	370

For lead lengths > 120 m please consult Franklin Electric.

Further potential energy savings due to more conservative lead sizing (< 3 % voltage drop) at 50 °C ambient.

ELECTRICAL CONNECTIONS DOL

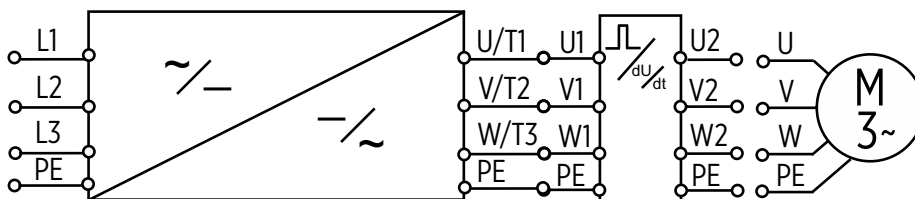

U	V	W	PE
brown	grey	black	yellow/green

8" REWINDABLE PERMANENT MAGNET MOTOR

MOTOR DIMENSIONS AND MATERIALS

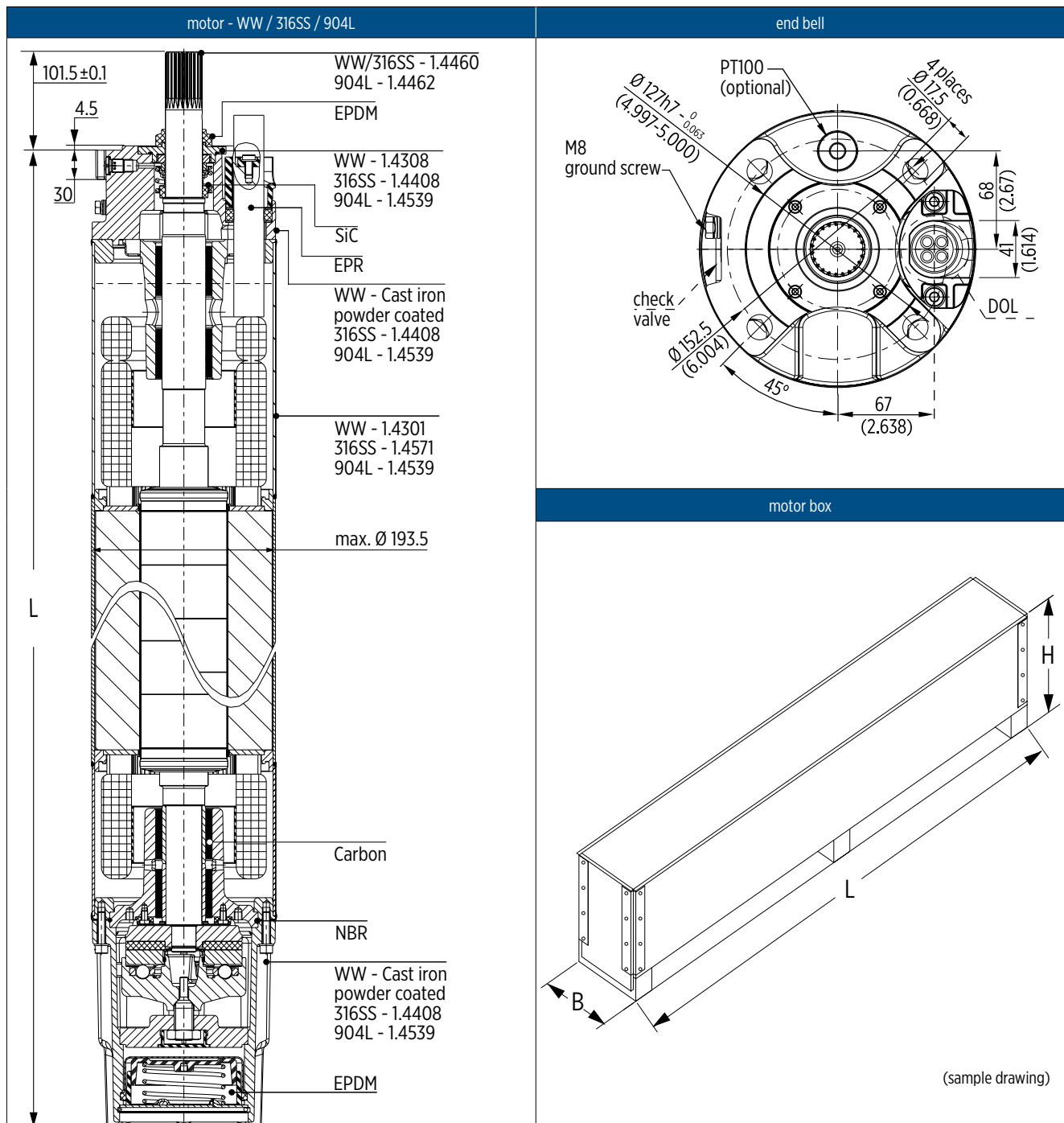

MOTOR WEIGHTS 304SS / 316SS / 904L

P [kW]	motor lengths L [mm]	motor weights [kg]		motor shipping size [mm]		
		without packaging	incl. packaging	B	H	L
75	1205	150	179	301	448	1596
100	1316	169	198			1596
130	1482	205	237			1996

SPARE PARTS 8" REWINDABLE PERMANENT MAGNET MOTOR

Kit	Kit description	materials	incl. positions	order no.
1	Thrust bearing kit	WW / 316SS / 904L	17, 20, 21, 32, 33	308 750 601
2	Radial bearing kit	WW / 316SS / 904L	15	308 751 603
3	seal kit	WW / 316SS	1-4, 11, 17, 25	308 800 603
		904L		308 800 604
4	Up-thrust bearing kit	WW / 316SS / 904L	18	308 751 602
5	Screw kit	WW / 316SS	2.0, 5, 8, 13, 24, 37, 40	308 660 601
		904L		308 660 602
6	Lead seal kit	WW / 316SS / 904L	5, 6, 7	→ page 158
7	PT100 kit	WW / 316SS / 904L	9	→ page 307
8	Valve Kit	WW	10, 11, 39	308 800 414

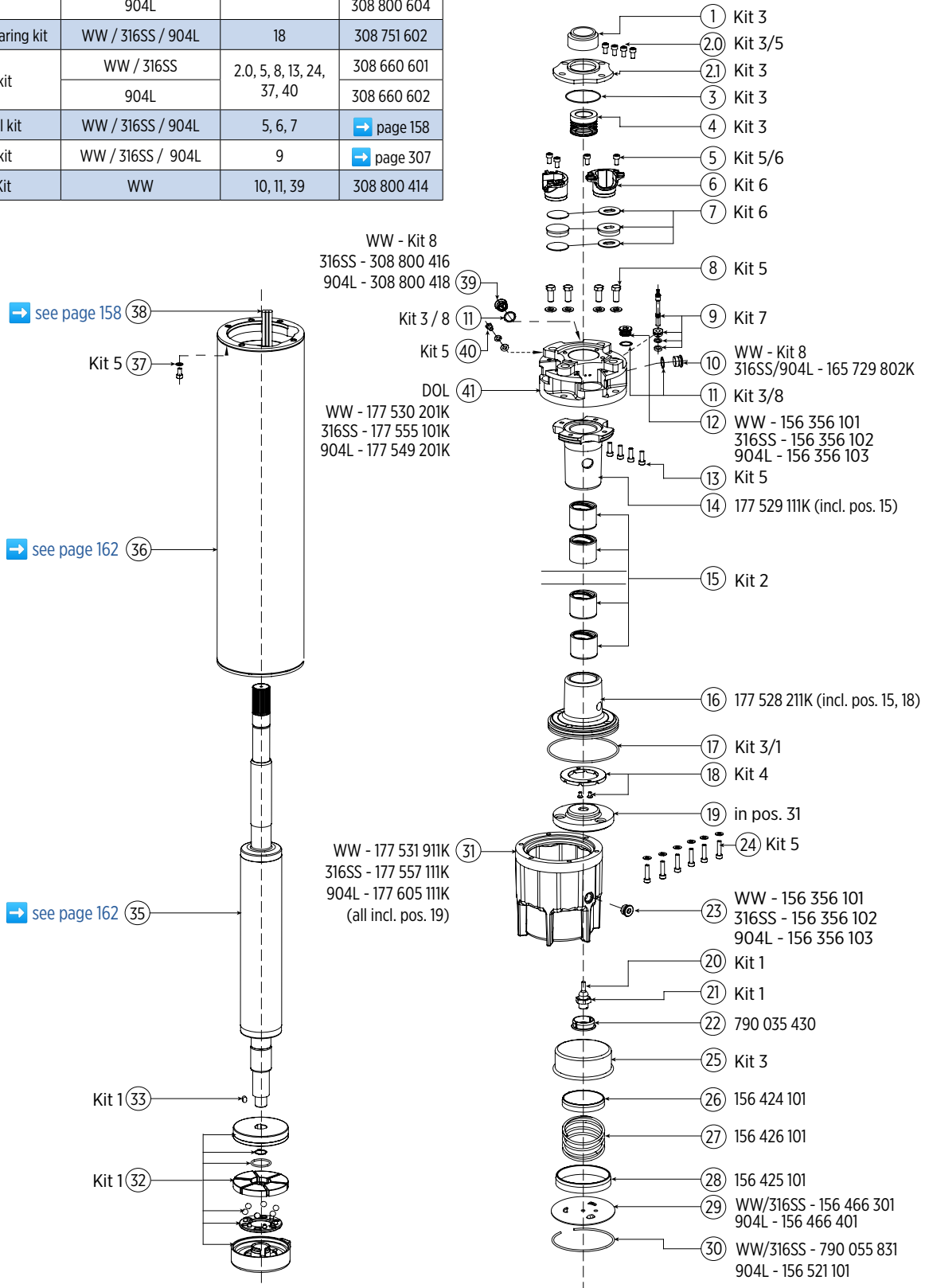

SPARE PARTS 8" REWINDABLE PERMANENT MAGNET MOTOR

STATOR AND ROTOR MODEL NUMBERS WW / 316 SS - 400 V / 100 HZ

P [kW]	Stator (incl. windings and 6 m motor lead)			rotor	
	U _N [V]	DOL [PE2/PA]		motors starting 08/2017	motors up to 07/2017
		motors starting 08/2017	motors up to 07/2017		
75	400 V	327 154 702K	327 154 901K	161 123 811K	161 123 801K
100	400 V	327 155 702K	327 155 901K	161 123 812K	161 123 802K
130	400 V	327 156 701K	-	161 123 814K	-

WINDING SPECIFICATION

P [kW]	U _N [V]	Model no. winding kit	Turns per coil	Wire diameter Ø [mm]	Type of Isolation	Group connection	Total wire length [m]	Resistance coil [Ω]	Resistance DOL (U1-V1) [Ω]
75	400	327 154 999	16	1.9/2.1 & 1.8/2.8 (2GR II)	PE2/PA	Parallel Y	290	0.146	0.167
	500	327 151 999	20	2.3/3.5 (2GR II)			350	0.235	0.235
100	400	327 155 999	12	2.0/3.1 & 2.1./3.3 (2GR II)	PE2/PA	Parallel Y	260	0.103	0.167
	500	327 144 999	17	2.5/3.8 (2GR II)			350	0.213	0.213
130	400	327 156 999	20	2.3/3.2/3.5 (4GR II)	PE2/PA	Parallel Y	486	0.115	0.121
	500								

INSULATION RESISTANCE (20 °C / 500 VDC)

New motor without drop cable	400 >	MΩ
Used motor without drop cable	20 >	MΩ
New motor with drop cable	4 >	MΩ
Used motor with drop cable	1	MΩ

MOTOR REPAIR INSTRUCTIONS

- Pictured repair instructions WW / 316SS / 904L (model no. 308 018 697)