

NM, NMS 60 Hz

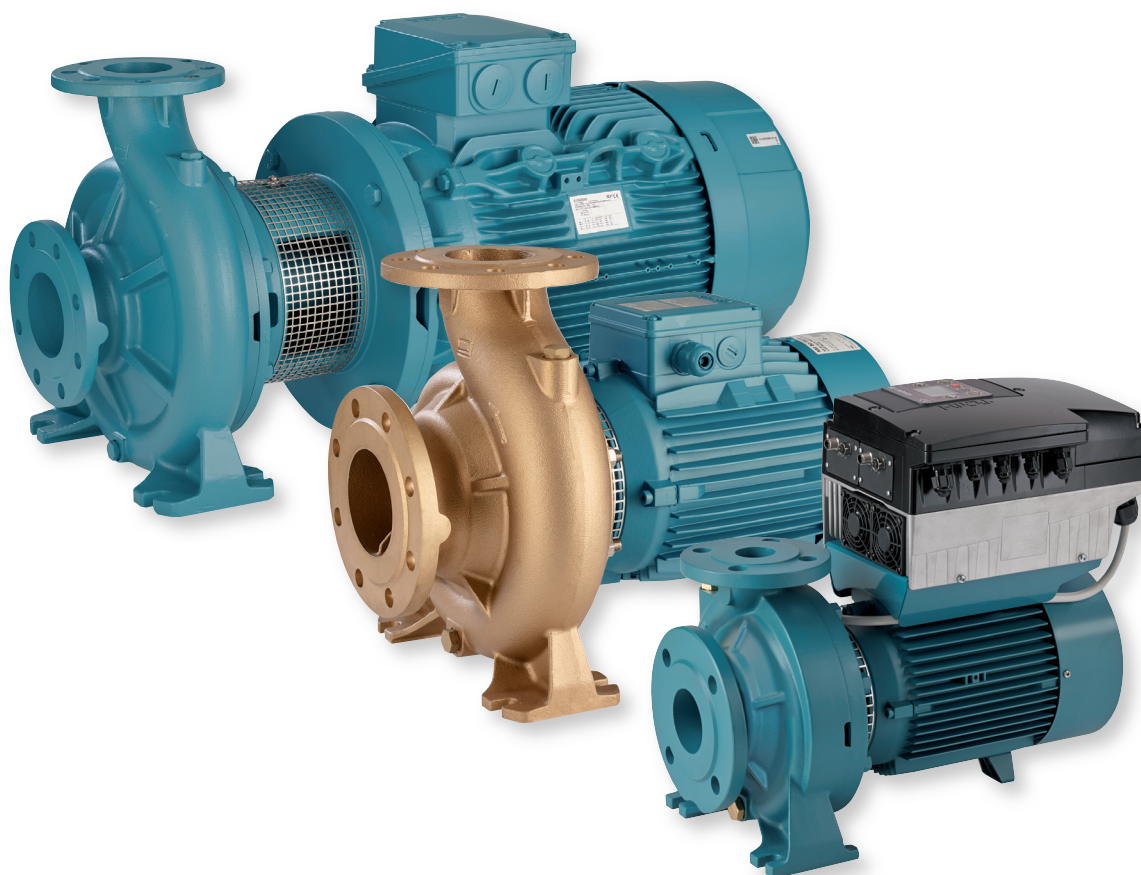

Close Coupled Centrifugal Pumps with flanged connections
Bombas centrífugas monobloc con bridas



Coverage chart - Campo de aplicaciones

$n \approx 3450$ rpm

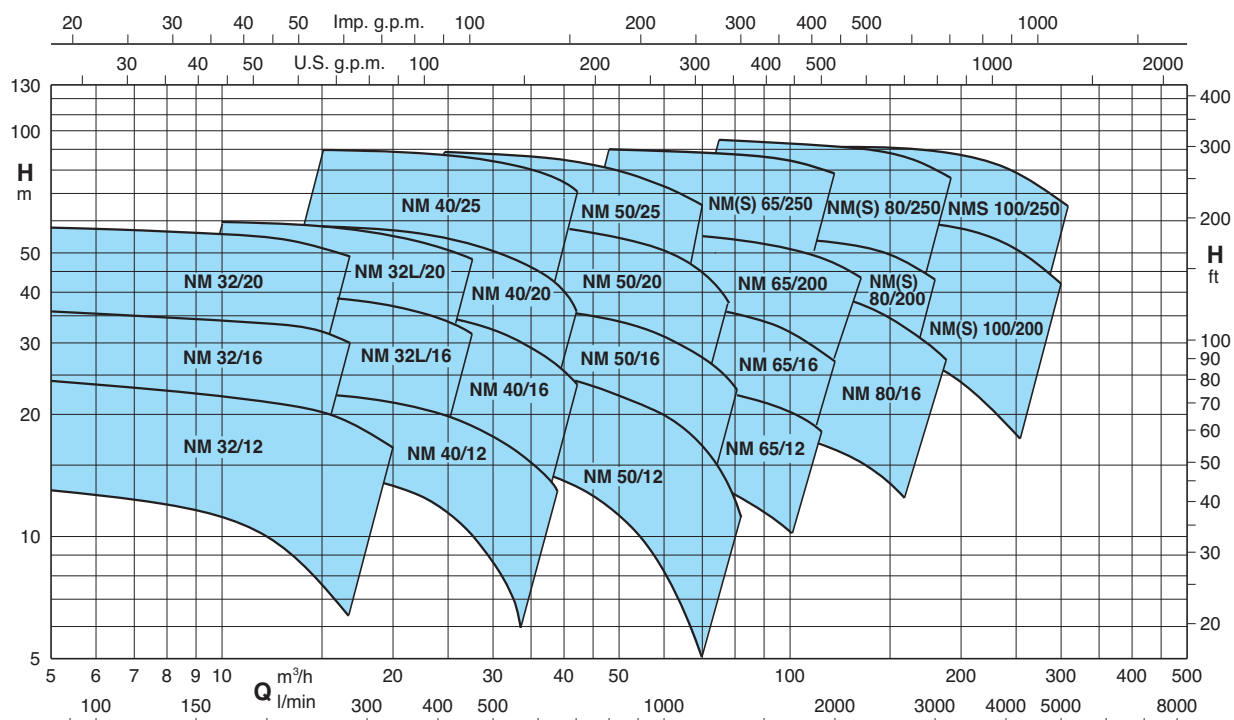

Construction

Close-coupled centrifugal pumps; electric motor with extended shaft directly connected to the pump up to 22 kW, new bracket construction for standard motors (stub-shaft construction) from 30 to 75 kW with integrated thrust bearing.

Pump casing with axial suction and radial delivery on top, main dimensions and performance according to EN 733.

NM(S): version with pump casing and lantern bracket in cast iron.

B-NM(S): version with pump casing and lantern bracket/casing cover in bronze. (the pumps are supplied fully painted).

Connections: Flanges according to PN 10, EN 1092-2.

Counter-flanges (on request)

Sizes	Flanges
from NM 32/... to NM 50/...	Screwed flanges EN 1092-1, PN 16
from NM 65/... to NMS 100/250	Flanges for welding EN 1092-1, PN 10

Version with frequency converter (on request)

Applications

- For clean liquids without abrasives, which are non-aggressive for the pump materials (solids content up to 0,2%).
- For water supply.
- For heating, air conditioning, cooling and circulation plants.
- For civil and industrial applications.
- For fire fighting applications.
- For irrigation.

Operating conditions

Liquid temperature from -10 °C to +90 °C.

Ambient temperature up to 40 °C.

Total suction lift up to 7 m.

Maximum permissible working pressure up to 10 bar (16 bar for NM 32L/16,20; NM 40/16,20; NM 50/12,16; NM 65/12,16,20,25; NM 80/16; NM 100/20).

Continuous duty.

Motor

2-pole induction motor, 60 Hz (n ≈ 3450 rpm).

NM, NMS: three-phase 220/380 V, 220/440 V, up to 3 kW; 380/660 V, from 4 to 75 kW;

Insulation class F.

Protection IP 54 (IP 55 for NMS).

Motor suitable for operation with frequency converter from 1,1 kW.

Classification scheme IE3 for three-phase motors from 0,75 kW.

Constructed in accordance with: EN 60034-1; EN 60034-30-1.

Special features on request

- Other voltages.
- Protection IP 55.
- Special mechanical seal.
- Packed gland (only for NM standard construction).
- Single-phase motor (NMM) up to 1.5 kW.
- Higher or lower liquid or ambient temperatures.
- Motor suitable for operation with frequency converter up to 0,75 kW.

Materials

Components	NM, NMS	B-NM, B-NMS
Pump casing Lantern bracket NM Casing cover for NMS	Cast iron GJL 200 EN 1561	Bronze G-Cu Sn 10 EN 1982
Lantern bracket NMS	Cast iron GJL 200 EN 1561	
Impeller	Cast iron GJL 200 EN 1561	Bronze G-Cu Sn 10 EN 1982
	Brass P- Cu Zn 40 Pb 2 UNI 5705 for NM,B-NM 32/12-16-20, NM,B-NM 40/20	
Shaft	Cr-Ni steel AISI 303	Cr Ni Mo steel AISI 316
	AISI 430 from 3 kW to 22 kW	
Mechanical seal	Carbon - Ceramic - NBR	
Counter-flanges	Steel Fe 430B UNI 7070	

Ejecución

Electrobombas centrífugas monobloc con acoplamiento directo motor-bomba y eje único hasta 22 kW, ejecución para motores normalizados IEC con cojinete axial integrado desde 30 hasta 75 kW (ejecución Stub-shaft). Cuerpo bomba con orificio de aspiración axial y orificio de impulsión vertical-radial, con dimensiones principales y prestaciones según EN 733.

NM(S): Ejecución con cuerpo bomba y acoplamiento en hierro.

B-NM(S): Ejecución con cuerpo bomba y acoplamiento/tapa del cuerpo en bronce. (Las bombas en bronce se suministran totalmente pintadas).

Orificios: Bridas PN 10, EN 1092-2.

Contrabridas (bajo demanda)

Modelos	Bridas
de NM 32/... a NM 50/...	Bridas roscadas EN 1092-1, PN 16
de NM 65/... a NMS 100/250	Bridas para soldar con aportación EN 1092-1, PN 10

Versión con variador de frecuencia (bajo demanda)

Aplicaciones

- Para líquidos limpios sin partes abrasivas, y no agresivas para los materiales de la bomba (con partes sólidas hasta 0,2% máx).
- Para el aprovisionamiento de agua.
- Para instalaciones de calefacción, acondicionamiento, refrigeración y circulación. - Para aplicaciones civiles e industriales.
- Para instalaciones contra incendios.
- Para irrigación.

Límites de empleo

Temperatura del líquido de -10 °C a +90 °C.

Temperatura ambiente hasta 40 °C.

Altura de aspiración manométrica hasta 7 metros.

Presión final máxima admitida en el cuerpo de la bomba 10 bar (16 bar para NM 32L/16,20; NM 40/16,20; NM 50/12,16; NM 65/12,16,20,25; NM 80/16; NM 100/20).

Servicio continuo.

Motor

Motor a inducción a 2 polos, 60 Hz (n ≈ 3450 1/min).

NM, NMS: trifásico 220/380 V, 220/440 V, hasta 3 kW. 380/660 V, de 4 a 75 kW.

Aislamiento clase F.

Protección IP 54 (IP 55 para NMS).

Motor preparado al funcionamiento con convertidor de frecuencia de 1,1 kW.

Clase eficiencia IE3 para motor trifásico de 0,75 kW.

Ejecución según EN 60034-1; EN 60034-30-1.

Otras ejecuciones bajo demanda

- Otras tensiones.
- Protección IP 55.
- Sello mecánico especial.
- Prensa estopas (solo para ejecución normal NM).
- Motor monofásico (NMM) hasta 1,5 kW.
- Para líquidos o ambientes con temperaturas más elevadas o más bajas.
- Motor preparado al funcionamiento con convertidor de frecuencia hasta 0,75 kW.

Materiales

Componentes	NM, NMS	B-NM, B-NMS
Cuerpo bomba Acoplamiento NM Tapa del cuerpo para NMS	Hierro GJL 200 EN 1561	Bronze G-Cu Sn 10 EN 1982
Acoplamiento NMS	Hierro GJL 200 EN 1561	
Rodete	Hierro GJL 200 EN 1561	Bronze G-Cu Sn 10 EN 1982
	Latón P- Cu Zn 40 Pb 2 UNI 5705 Para NM,B-NM 32/12-16-20, NM,B-NM 40/20	
Eje	Acero al Cr-Ni AISI 303	Acero al Cr-Ni-Mo AISI 316
	AISI 430 de 3 kW a 22 kW	
Sello mecánico	Carbón - Cerámica - NBR	
Contrabridas	Acero Fe 430B UNI 7070	

NM EI 60 Hz

Pumps with frequency converter

The **NM EI** pumps are available with power from 0,55 kW up to 22 kW, the pumps are equipped with **I-MAT** installed on board which allows to realize a variable-speed system extremely compact and efficient, ideal in applications of water supply and in the distribution of hot and cold water.

The pump is equipped with transducers suitable for operation and is already programmed at the factory.

Advantages

- Energy saving
- Compact design
- Easy to use
- Programmable to suit the system requirements
- Reliability

Costruction

The system comprises of:

- Pump
- Induction motor
- I-MAT Frequency converter
- Motor adapter for the motor mounting of the frequency converter
- Connection cable between frequency converter and induction motor
- Transducers

Main features

- Rated motor power output from 0,55 kW to 22 kW
- Control range from 1750 to 3450 rpm (2-pole)
- Protection against dry running
- Protection against operations with closed valve ports
- Protection against system leakages
- Protection against overcurrent in the motor
- Protection against overvoltage and undervoltage of the power supply
- Protection against current unbalances between phases

Operating modes



Constant pressure mode
with pressure transducer

In this mode, the system maintains the preset pressure when the flow required by the installation changes.



Proportional pressure mode
with pressure transducer

In this mode the system changes the working pressure according to the required flow rate.



Constant flow mode
with flow meter

In this mode the system maintains a constant flow rate value in a point of the installation according to the required pressure.



Fixed speed mode
with setting of the speed preferential rotation.

In this mode, by changing the working frequency, you may choose any operational curve included within the working range.



Constant temperature mode
with temperature transducer

In this mode the system keeps the temperature constant inside a system by changing the speed of the pump.

Bomba a velocidad variable

La bomba **NM EI** se encuentra disponible con potencias de 0,55 kW a 22 kW y llevan incorporado un variador **I-MAT** que permite realizar un sistema de velocidad variable extremadamente compacto y eficiente, ideal para aplicaciones de abastecimiento de agua y la distribución de agua fría y caliente.

Bomba eléctrica es suministrada con un transductor de presión idóneo para el modo operación que escoja el cliente y programado directamente desde fábrica

Ventajas

- Ahorro de energía
- Diseño compacto
- Fácil de usar
- Programable para las necesidades del sistema
- Fiabilidad

Construcción

- El sistema está compuesto por:
- Bomba
- Motor de inducción
- I-MAT variador de frecuencia
- Adaptador del motor para el montaje del variador de frecuencia
- Cable de conexión entre en variador y la bomba eléctrica
- Transductores



Límites de utilización

- Potencia nominal del motor desde 0,55 kW hasta 22 kW
- Rango de control desde 1750 hasta 3450 rpm (2 polos)
- Protección contra el funcionamiento en seco
- Protección contra el funcionamiento con válvula cerrada
- Protección contra fugas del sistema
- Protección contra sobrecorriente del motor
- Protección contra sobrevoltaje o bajovoltaje de la red de alimentación
- Protección contra el desequilibrio de fases

Modos de operación

Modo presión constante
con sensor de presión

En el modo de presión constante, el sistema mantiene la presión prefijada cuando cambia el caudal por los cambios de la instalación.

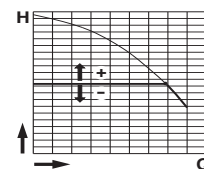

Modo presión proporcional
con sensor de presión

En el modo de presión proporcional, el sistema cambia la presión de trabajo de acuerdo al caudal requerido.

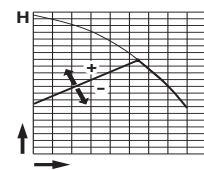

Modo caudal constante
con medidor de caudal

En el modo caudal constante el sistema mantiene el caudal constante en un punto de la instalación de acuerdo a la presión requerida.

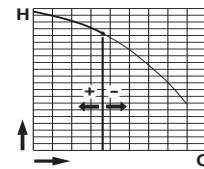

Modo velocidad fija
con el ajuste de la velocidad de rotación preferencial

En el modo velocidad fija, cambiando la frecuencia de trabajo, se puede escoger cualquier curva operativa dentro del rango de trabajo de la bomba.

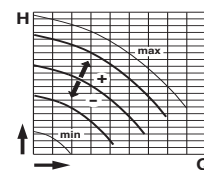

Modo temperatura constante
con sensor de temperatura

En este modo el sistema mantiene la temperatura constante dentro de un sistema cambiando la velocidad de la bomba.

Performance - Prestaciones

n ≈ 3450 rpm

B-NM	NM	P ₂		Q m³/h l/min	6,6	7,5	8,4	9,6	10,8	12	13,2	15	16,8	18,9	21	24	27	29	32	
		kW	HP		110	125	140	160	180	200	220	250	280	315	350	400	450	483	533	
B-NM 32/12F-60	NM 32/12FE-60	0,55	0,75	H m	12,4	12,1	11,7	11,1	10,4	9,6	8,6	7								
B-NM 32/12D-60	NM 32/12DE-60	0,75	1		18,8	18,5	18,3	17,8	17,2	16,5	15,8	14,4								
B-NM 32/12A-60/A	NM 32/12A-60/A	1,1	1,5		24,3	24,1	23,8	23,4	22,8	22,2	21,4	20,1								
B-NM 32/12S-60/A	NM 32/12S-60/A	1,5	2		25,2	25	24,8	24,3	23,8	23,2	22,5	21,2	19,7*	17,8*	15,6*	12*				
B-NM 32/16B-60/A	NM 32/16B-60/A	1,5	2		31	30,5	30	29,5	29	28	27	25*	23*							
B-NM 32/16A-60/B	NM 32/16A-60/B	2,2	3		36,5	36	35,5	35	34	33	32,5	31*	29*							
B-NM 32/20D-60/B	NM 32/20D-60/B	2,2	3		39	38	37,5	36,9	35	34	32									
B-NM 32/20C-60/A	NM 32/20C-60/A	3	4		45	44,5	44	43	42	41	40	37	34*							
B-NM 32/20A-60/B	NM 32/20A-60/B	4	5,5		57	56,5	56	55,5	55	54	53	51	49*							
B-NM 32L/16C-60	NM 32L/16C-60	2,2	3					26,1	25,9	25,6	25,3	24,6	23,7	22,3	20,6	17,6	13,7			
B-NM 32L/16B-60	NM 32L/16B-60	3	4					30,3	30,2	30	29,8	29,3	28,6	27,5	26,1	23,5	20,1			
B-NM 32L/16A-60	NM 32L/16A-60	4	5,5					38,7	38,6	38,5	38,4	38	37,6	36,8	35,7	33,6	30,7	28,3	23,9	
B-NM 32L/20C-60	NM 32L/20C-60	4	5,5					46,1	45,8	45,3	44,7	43,6	42,1	39,9	37	31,9	25,6			
B-NM 32L/20B-60	NM 32L/20B-60	5,5	7,5					52,4	52,2	51,9	51,5	50,6	49,4	47,4	44,9	40,3	34,8	30,6		
B-NM 32L/20A-60	NM 32L/20A-60	7,5	10					60,4	60,3	60,1	59,8	59,2	58,4	57	55	51,2	46,2	42,2	35,3	

B-NM	NM	P ₂		Q m³/h l/min	15	16,8	18,9	21	24	27	30	33	37,8	39	42	45	48	54		
		kW	HP		250	280	315	350	400	450	500	550	630	650	700	750	800	900		
B-NM 40/12F-60/A	NM 40/12F-60/B	1,1	1,5	H m	15,4	14,9	14,3	13,4	11,8	10	7,8	5,6								
B-NM 40/12C-60/A	NM 40/12C-60/B	1,5	2		18,5	18,1	17,6	17	15,8	14,2	12,4	10,5	6,9							
B-NM 40/12A-60/B	NM 40/12A-60/C	2,2	3		22,5	22,3	21,9	21,4	20,6	19,6	18,3	16,7	13,7	12,9						
B-NM 40/16C-60/B	NM 40/16C-60/C	2,2	3		25,5	25,1	24,4	23,6	22,1	20,1	17,8	15,4	10,6							
B-NM 40/16B-60/A	NM 40/16B-60/B	3	4		31	30,6	30,3	29,6	28,5	27,1	25,4	23,2	19,2	18,1						
B-NM 40/16A-60/B	NM 40/16A-60/C	4	5,5		37,1	36,9	36,5	36,1	35,2	34,3	33,2	31,8	28,8	27,9	25,6	23				
B-NM 40/20C-60/B	NM 40/20C-60/C	4	5,5		44	43	42	41	39	36										
B-NM 40/20B-60/A	NM 40/20B-60/A	5,5	7,5		52	51,5	50,5	49,5	47,5	44,5	40	35								
B-NM 40/20AR-60/A	NM 40/20AR-60/A	5,5	7,5		56,5	56	55	54	52	49										
B-NM 40/20A-60/A	NM 40/20A-60/A	7,5	10		59,5	59	58,5	58	56	53,5	50,5	47	38,5							
B-NM 40/25C-60/C	NM 40/25C-60/C	9,2	12,5		65,4	65	64,4	63,5	61,5	58,6	54,2	49								
B-NM 40/25B-60/C	NM 40/25B-60/C	11	15		71,5	71,3	70,8	70,3	68,9	66,4	63,3	59,2	50							
B-NM 40/25A-60/C	NM 40/25A-60/C	15	20		90,4	90,2	89,7	89,1	88,5	87,3	86,1	83,8	78	76						

B-NM	NM	P ₂		Q m³/h l/min	24	27	30	33	37,8	42	48	54	60	66	69	72	75	84		
		kW	HP		400	450	500	550	630	700	800	900	1000	1100	1150	1200	1250	1400		
B-NM 50/12F-60/B	NM 50/12F-60/C	2,2	3	H m			16,1	15,4	14,2	13	11,1	8,6	5,8							
B-NM 50/12D-60/A	NM 50/12D-60/B	3	4				19,4	19	18	17	15,5	13,5	11,1	8,4						
B-NM 50/12A-60/B	NM 50/12A-60/C	4	5,5				24,8	24,6	24	23,4	22,3	20,8	19	17	16	14,8	13,6			
B-NM 50/16B-60/B	NM 50/16B-60/B	5,5	7,5				35,3	34,9	33,6	32,4	30,1	27,5	24,5	20,9	19	17,1	15,1			
B-NM 50/16A-60/B	NM 50/16A-60/B	7,5	10				42,7	41,6	41,2	40,3	38,5	36,3	33,8	30,9	29,4	27,8	26,1	20,4		
B-NM 50/20B-60/C	NM 50/20B-60/C	9,2	12,5			51	50,6	50,4	49,8	48,5	47,1	44	40,5	36	30,2	27,3				
B-NM 50/20A-60/C	NM 50/20A-60/C	11	15			57,6	57,7	57,3	56,9	55,7	54,6	52,2	49,5	46	41,8	39	36,2	33,2		
B-NM 50/25C-60/C	NM 50/25C-60/C	11	15			61,9	61,2	60,3	59,3	57,2	55	50	44	36,5						
B-NM 50/25B-60/C	NM 50/25B-60/C	15	20			74,6	73,9	73,2	72	70,1	68,1	64,3	59,3	52,8	43,8					
B-NM 50/25A-60	NM 50/25A-60/D	18,5	25			87,6	87,3	86,9	86,2	84,7	83	79,8	76	72	66,9					

B-NM	NM	P ₂		Q m³/h l/min	37,8	42	48	54	60	66	75	84	96	108	120	132	141	150		
		kW	HP		630	700	800	900	1000	1100	1250	1400	1600	1800	2000	2200	2350	2500		
B-NM 65/12E-60/A	NM 65/12E-60/C	4	5,5	H m	16	15,8	15,5	15,2	14,8	14,3	13,5	12,7	11,4	9,9						
B-NM 65/125C-60/B	NM 65/12C-60/B	5,5	7,5		21,4	21,2	21	20,6	20,3	19,8	19,1	18,3	17	15,3	13,1					
B-NM 65/125A-60/B	NM 65/12A-60/B	7,5	10		26,4	26,4	26,2	26,1	25,8	25,5	24,9	24,1	22,8	21,1	18,9					
B-NM 65/160D-60/B	NM 65/16D-60/B	7,5	10				24,4	24,2	23,9	23,6	23	22,3	21,2	19,7	17,6					
B-NM 65/160C-60/C	NM 65/16C-60/C	9,2	12,5				27,9	27,8	27,6	27,3	26,7	26	24,9	23,4	21,5	19				
B-NM 65/160B-60/C	NM 65/16B-60/C	11	15				32,8	32,7	32,5	32,2	31,7	31	29,9	28,5	26,8	24,4				
B-NM 65/160AR-60	NM 65/16AR-60	15	20				35,9	35,9	35,8	35,7	35,3	34,7	33,6	32,3	30,7	28,5				
B-NM 65/160A-60/C	NM 65/16A-60/C	15	20				40,7	40,7	40,6	40,5	40,1	39,6	38,6	37,3	35,5	33,2				
B-NM 65/200C-60/C	NM 65/20C-60/C	15	20				45,1	44,9	44,5	44,1	43,2	42,2	40,5	38,6	36,2	33,2	30,4			
B-NMS 65/200B-60	NM 65/20B-60/D	18,5	25				52,8	52,8	52,6	52,3	51,5	50,5	48,8	46,7	44,3	41,4	38,7			
B-NMS 65/200A-60	NM 65/20A-60/A	22	30				58,5	58,5	58	58	57,5	56,5	55	53	50,5	47,5	45,5			
B-NM 65/250C-60/B	NM 65/25C-60/A	22	30				63	63	62,5	62	60,5	59	56,5	53	49	43				
B-NMS 65/250B-60/A	NMS 65/250B-60/A	30	40				74	74	74	74	73	72	70	67,5	64	60,5				
B-NMS 65/250A-60/B	NMS 65/250A-60/B	37	50				87	87,5	87,5	87,5	87	86	84,5	81,5	78	74,5				

Performance - Prestaciones

n ≈ 3450 rpm

B-NM	NM	P ₂		Q m ³ /h l/min	H m															
		kW	HP		75	84	96	108	120	132	150	168	180	192	210	240	270	300		
B-NM 80/160E-60/B	NM 80/16E-60/B	7,5	10	23,3	22,2	20,6	19	17,5	16	14,1	11,9									
B-NM 80/160D-60/C	NM 80/16D-60/C	9,2	12,5	26,9	25,9	24,6	23,1	21,6	19,9	17,5	15,1									
B-NM 80/160C-60/C	NM 80/16C-60/C	11	15	30,7	29,9	28,7	27,4	26	24,4	22	19,5	17,9								
B-NM 80/160B-60/C	NM 80/16B-60/C	15	20	35,5	34,9	34	32,9	31,6	30,2	27,8	25	23,1	21							
B-NM 80/16A-60	NM 80/16A-60/D	18,5	25	41,3	40,9	40,2	39,3	38,3	37,1	35	32,5	30,7	28,8							
B-NMS 80/200B-60/B	NM 80/20B-60/A	22	30	43	42,7	42,0	41,2	40,2	39,2	37,4	35,3	33,8	32,2							
B-NMS 80/200A-60/B	NMS 80/200A-60/A	30	40	58	57,7	57,2	56,5	55,6	54,5	52,6	50,6	49,2	47,8							
B-NMS 80/250E-60/A	NM 80/25E-60	22	30	51	50	48,5	46,5	55,6	42*	38*	33*	29*								
B-NMS 80/250D-60/A	NMS 80/250D-60	30	40	65	64	62,5	61	59*	56,5*	53*	49*	45*	41*							
B-NMS 80/250C-60/A	NMS 80/250C-60/A	37	50	73,5	73	72	70,5	69*	67*	63*	59*	55*	51*							
B-NMS 80/250B-60/A	NMS 80/250B-60/A	45	60	84	83,5	82,5	81	80*	78*	74*	70*	67*	62,5*							
B-NMS 80/250A-60/A	NMS 80/250A-60/A	55	75	94,5	94	93	92,5	91,5*	90*	87,5*	84*	80*	76,5*							
B-NMS 100/200E-60/B	NM 100/20E-60/A	18,5	25				30	29,5	29	28	27	26*	24,5*	22,5*	19*					
B-NMS 100/200D-60/A	NM 100/20D-60	22	30				36	35,5	35	34	33	32*	31*	29*	24*					
B-NMS 100/200C-60/A	NMS 100/200C-60	30	40				45	44,5	44	43	42,5	41*	40*	39*	34*	28*				
B-NMS 100/200B-60/A	NMS 100/200B-60/A	37	50				54	53,5	53	52,5	51,5	50*	49*	47,5*	43*	38*				
B-NMS 100/200A-60/A	NMS 100/200A-60/A	45	60				61,5	61	60,5	60	59,5	59*	58*	56*	52,5*	48*	42*			
B-NMS 100/250B-60/A	NMS 100/250B-60/A	55	75				73,5	73	72,5	71,5	70	69*	67*	65*	60*	55*	48*	42*		
B-NMS 100/250A-60/A	NMS 100/250A-60/A	75	100				90,5	90	90	89	88,5	87,5*	87*	85*	81*	75*	67*	42*		

NM(S) Standard construction.
Ejecución normal.

B-NM(S) Bronze construction.
Ejecución en bronce.

P₂ Rated motor power output.
Potencia nominal del motor.

H Total head in m.
Altura total en m.

* Maximum suction lift 1-2 m.
Altura máxima de aspiración manométrica 1-2 m.

◦ With 1 m suction head.
Carga positiva mínima 1 m.

Tolerances according to UNI EN ISO 9906:2012.
Tolerancias según UNI EN ISO 9906:2012.

Rated currents - Intensidades nominales

P ₂		P ₂ *	SF	220V Δ / 380V Y			220V Δ / 440V Y		440V Δ IN A	IA/IN
kW	HP	kW		IN A	IN A	IN A	IN A	IN A		
0,55	0,75	0,63	1,15	4,5	2,6		4,7	2,7		5,2
0,75	1	0,86	1,15	4,8	2,8		5,0	3,0		6
1,1	1,5	1,27	1,15	5,7	3,3		6,0	3,5		5,4
1,5	2	1,75	1,15	9	5,2		9,4	5,5		6,1
2,2	3	2,55	1,15	11,1	6,4		11,7	6,8		8,4
3	4	3,45	1,15	13,4	7,7		14,0	8,1		8,4
4	5,5	4,55	1,15		11,2	6,5				9,2
5,5	7,5	6,3	1,15		13,7	7,9				8,7
7,5	10	8,6	1,15		17	9,8				9,2
9,2	12,5	10,6	1,15		22	12,7				8,3
11	15	12,6	1,15		25,8	14,9				8,9
15	20	17,3	1,15		33,2	19,2				9,4
18,5	25	21,3	1,15		40,8	23,6				9,4
22	30	24,5	1,15		48,9	28,3				9,6
30	40	33,5	1,15		65,4	37,8			55	8,7
37	50	41,5	1,15		82	47			66	8,5
45	60	51	1,15		97	56			81	8
55	75	62	1,15		119	68,5			97	7,2
75	100	84	1,15		157	90			132	6

P₂ Rated motor power output.
Potencia nominal del motor.

* Power with S.F.
Potencia con S.F.

IA/IN D.O.L. starting current / Rated current
Intensidad de arranque / Intensidad nominal

Rated power on the nameplate
Potencia nominal de la placa de identificación

Characteristic curves - Curvas Características

$n \approx 3450$ rpm

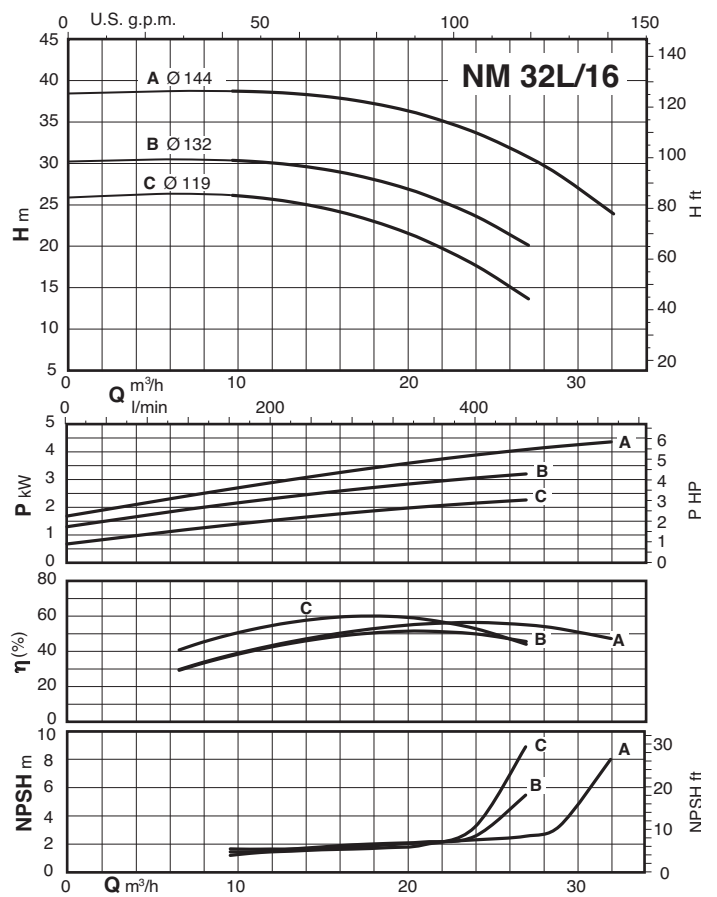
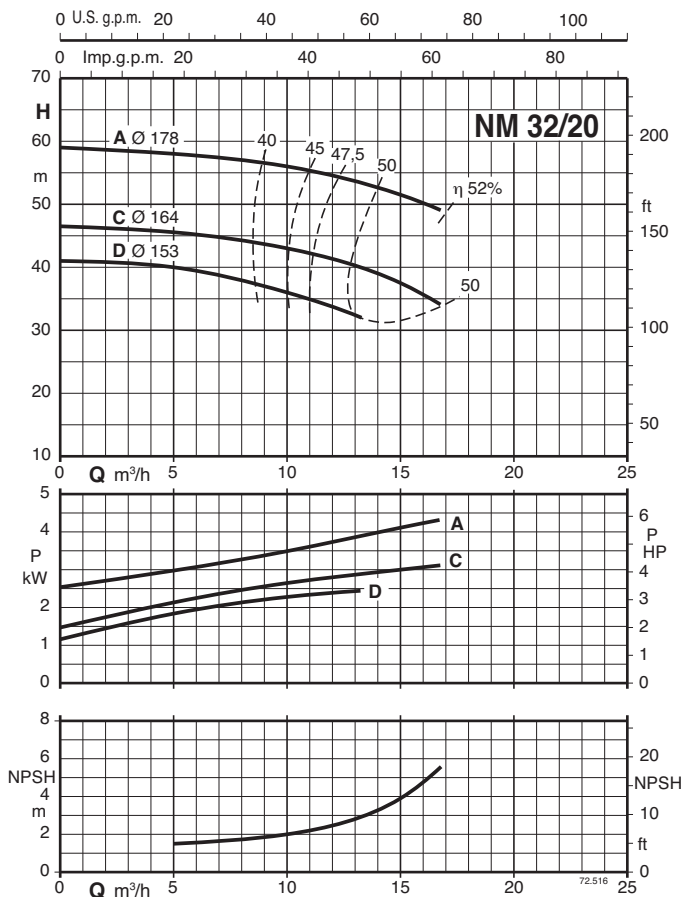
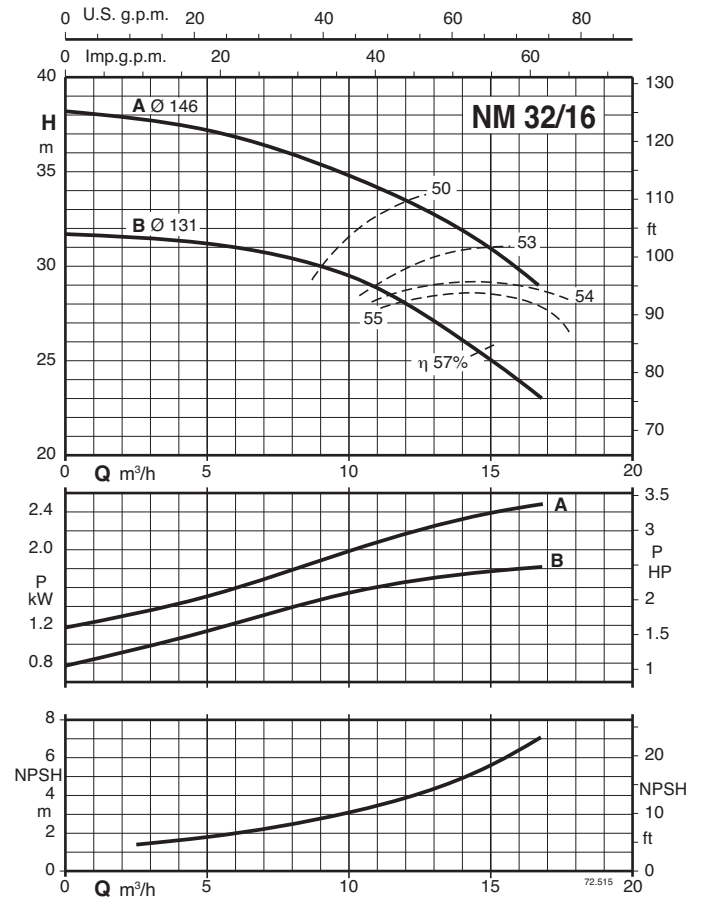
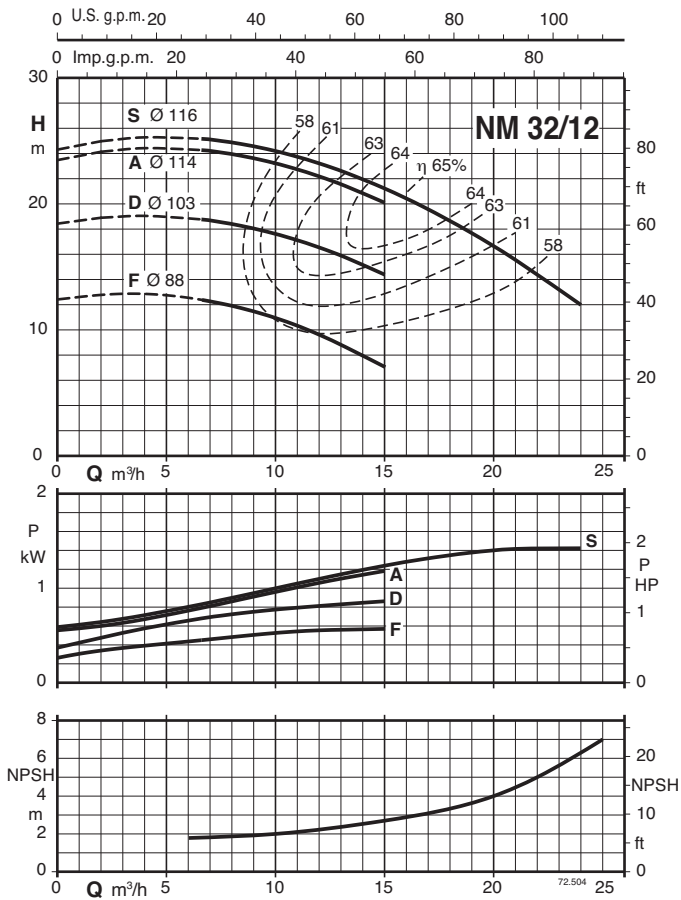

Characteristic curves - Curvas Características

$n \approx 3450$ rpm

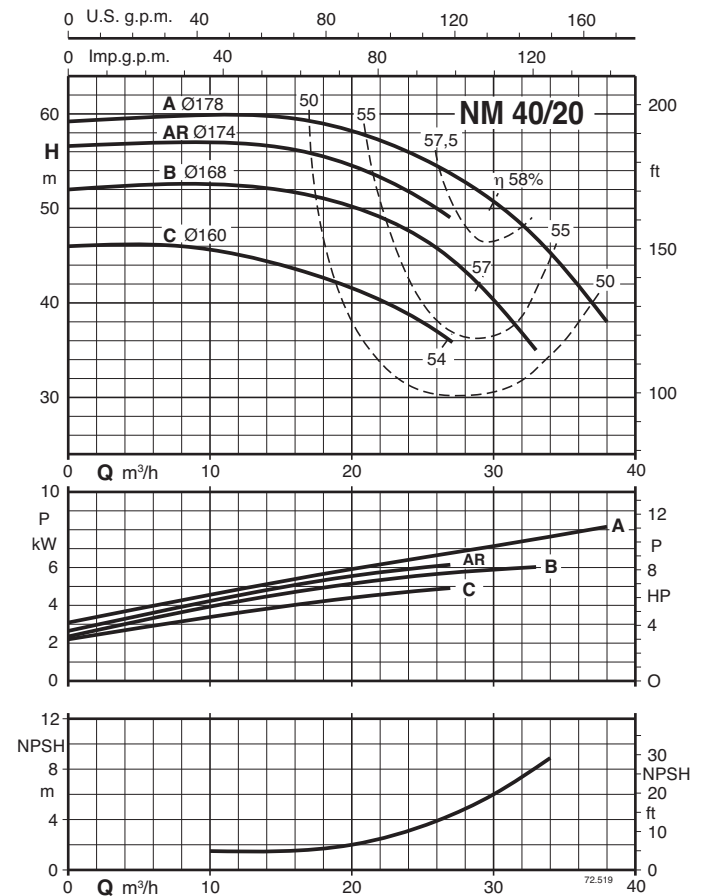
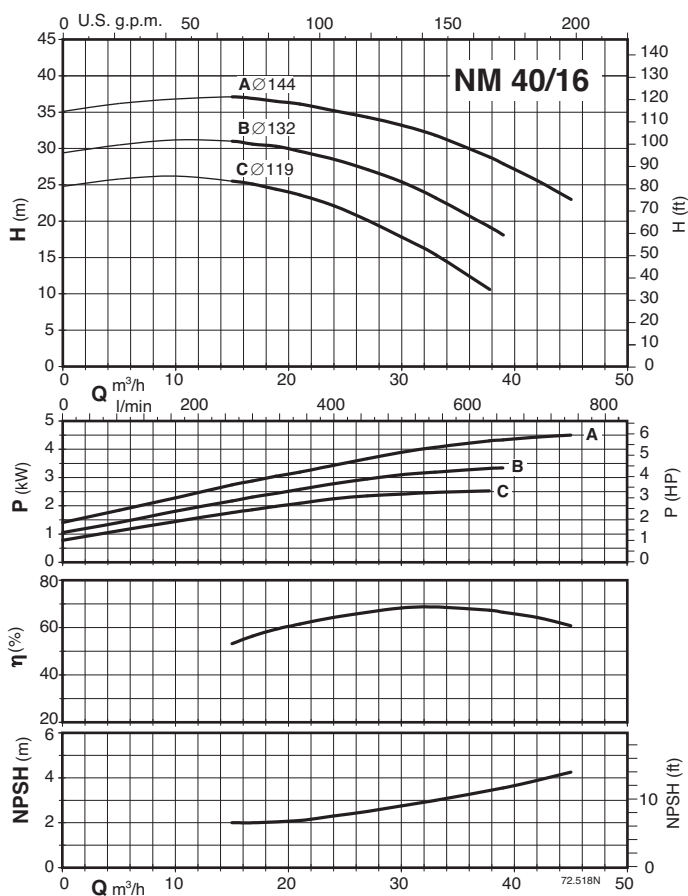
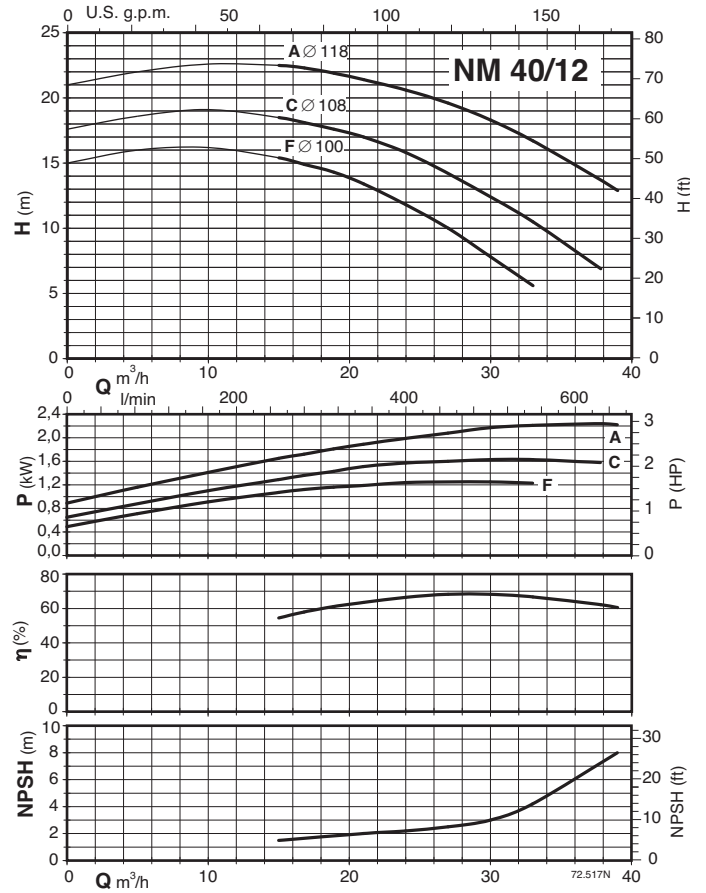
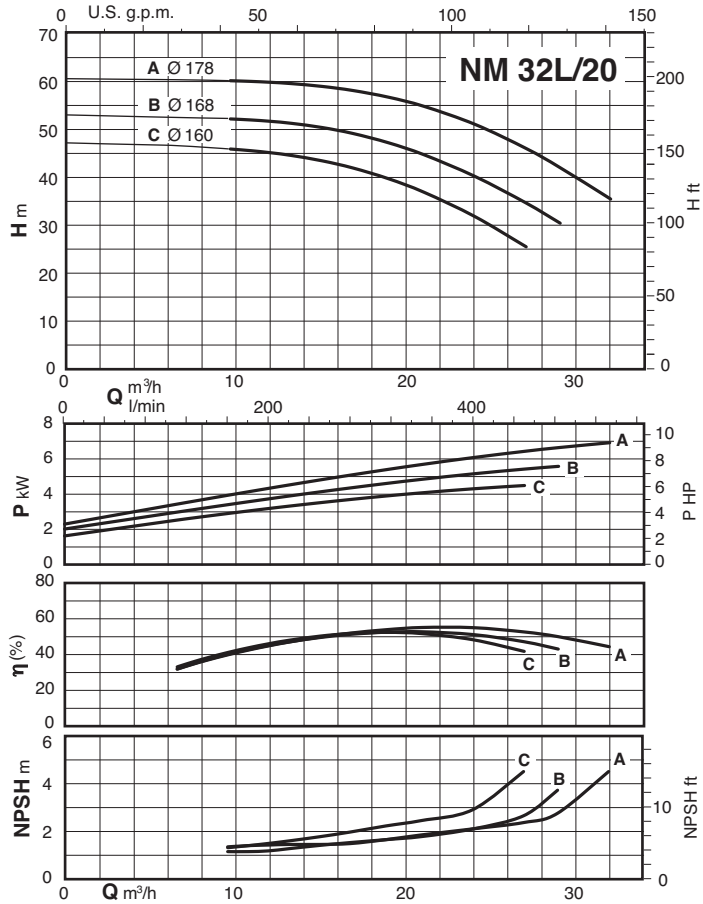

Characteristic curves - Curvas Características

$n \approx 3450$ rpm

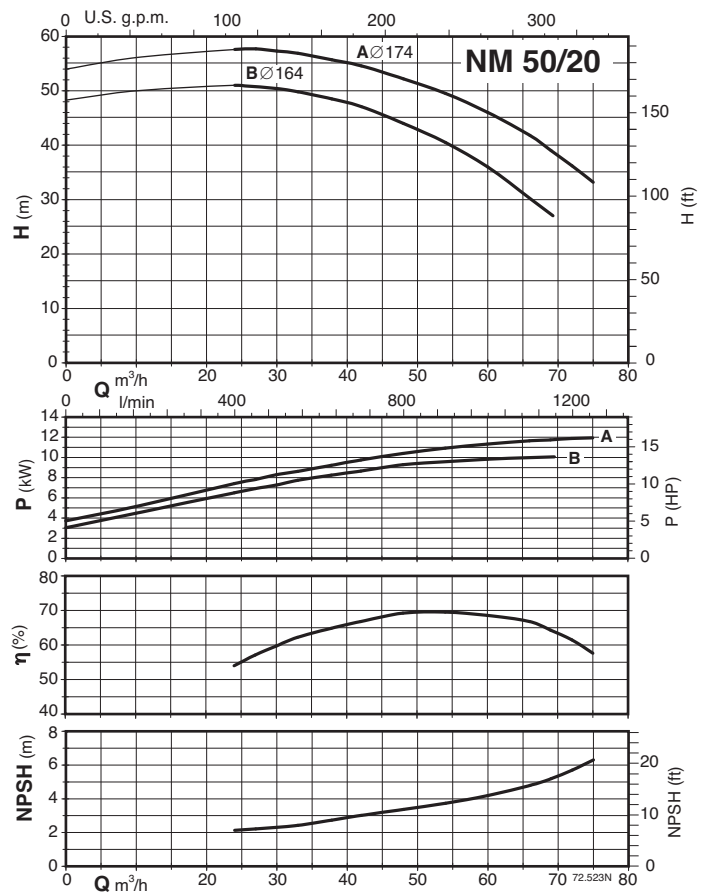
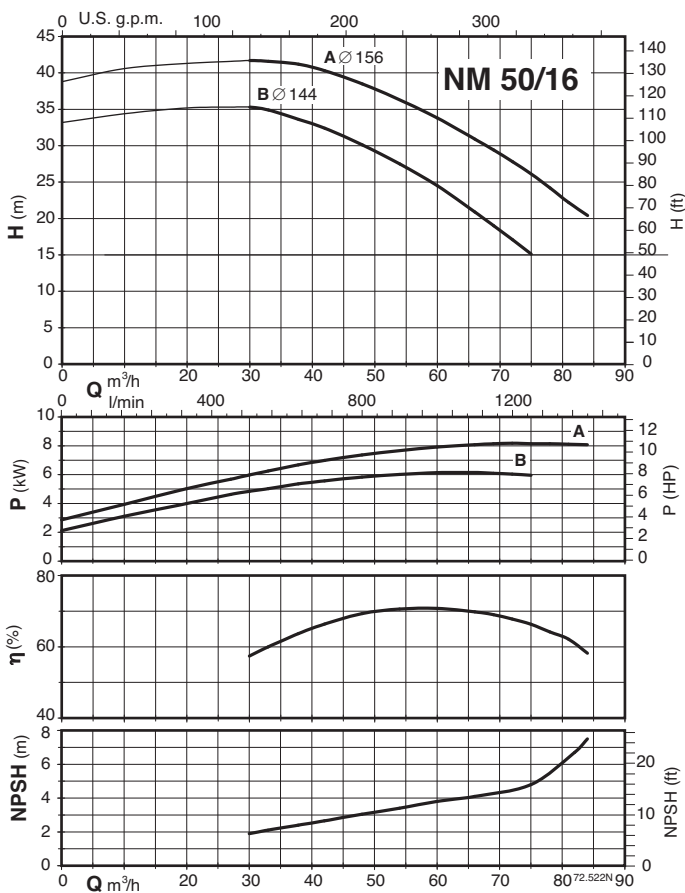
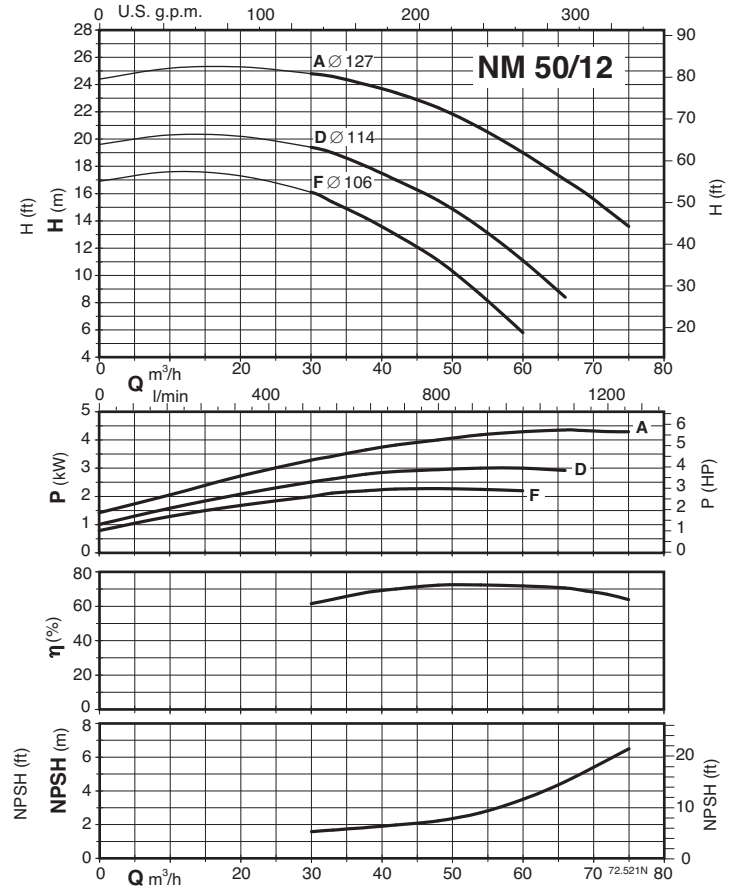
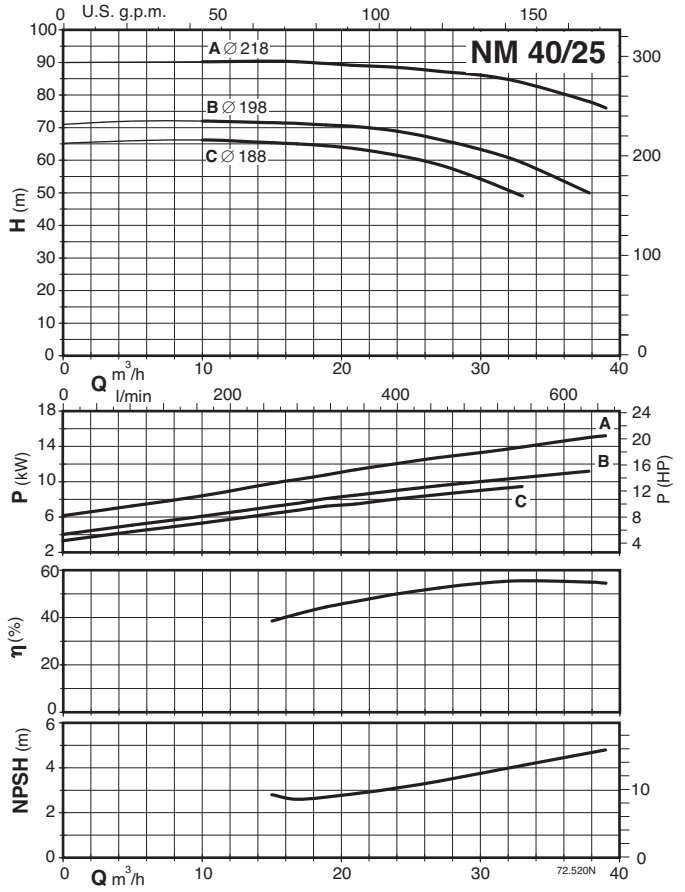

Characteristic curves - Curvas Características

$n \approx 3450$ rpm

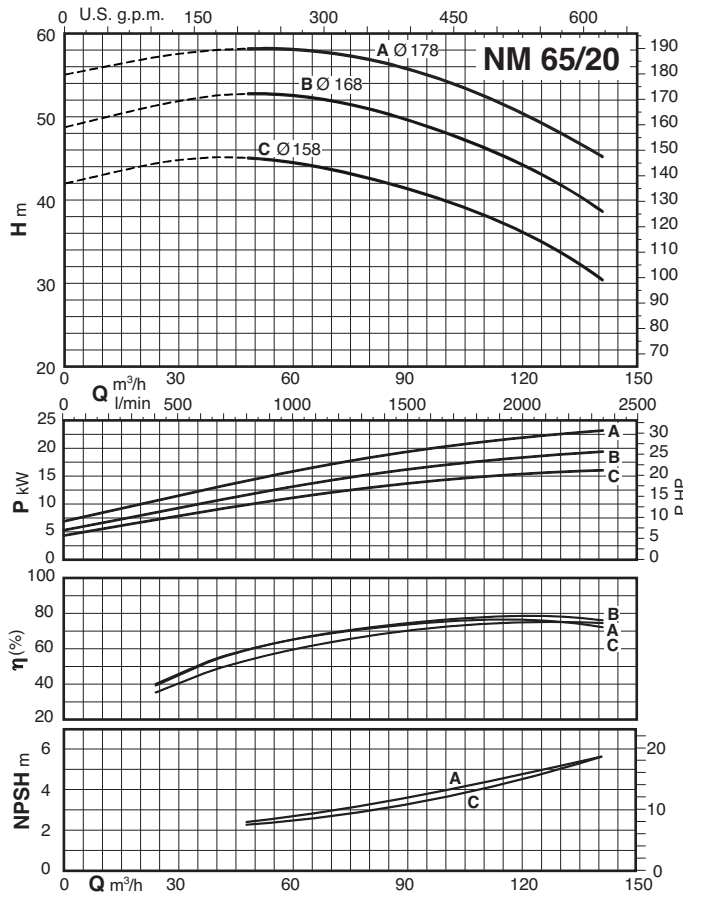
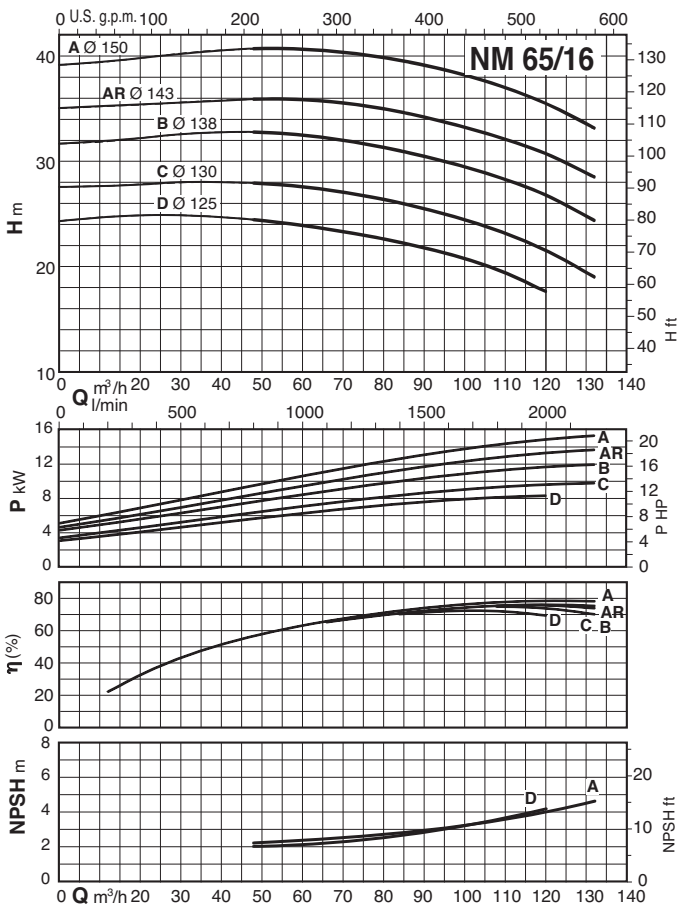
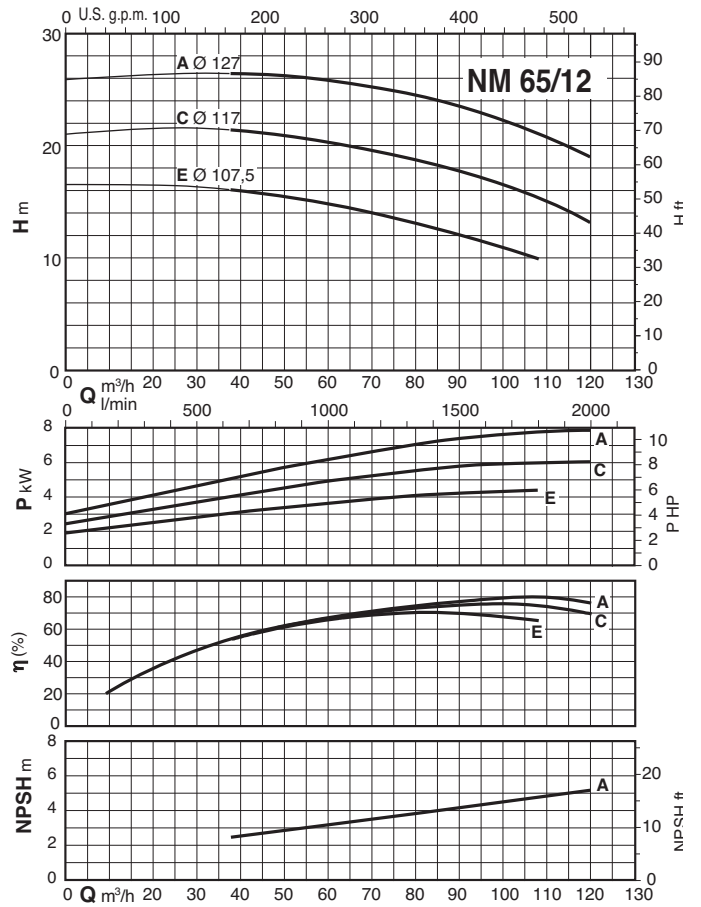
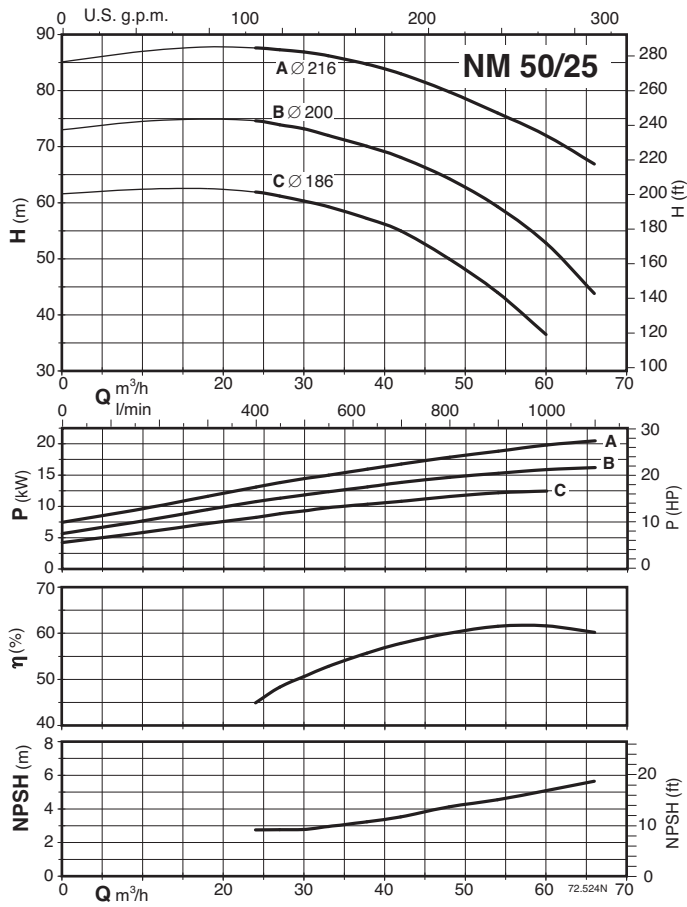

Characteristic curves - Curvas Características

$n \approx 3450$ rpm

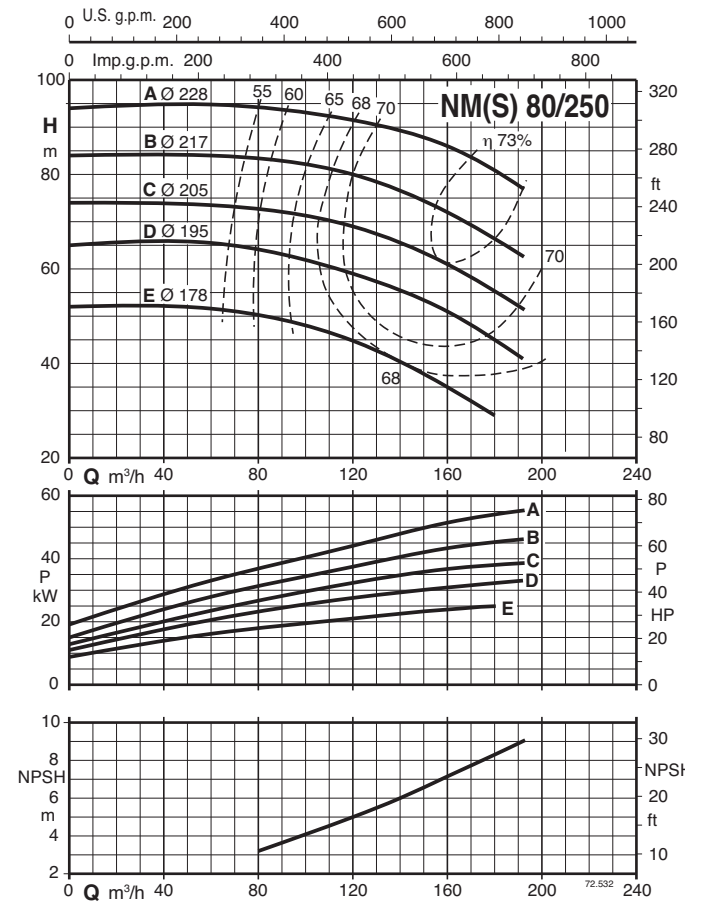
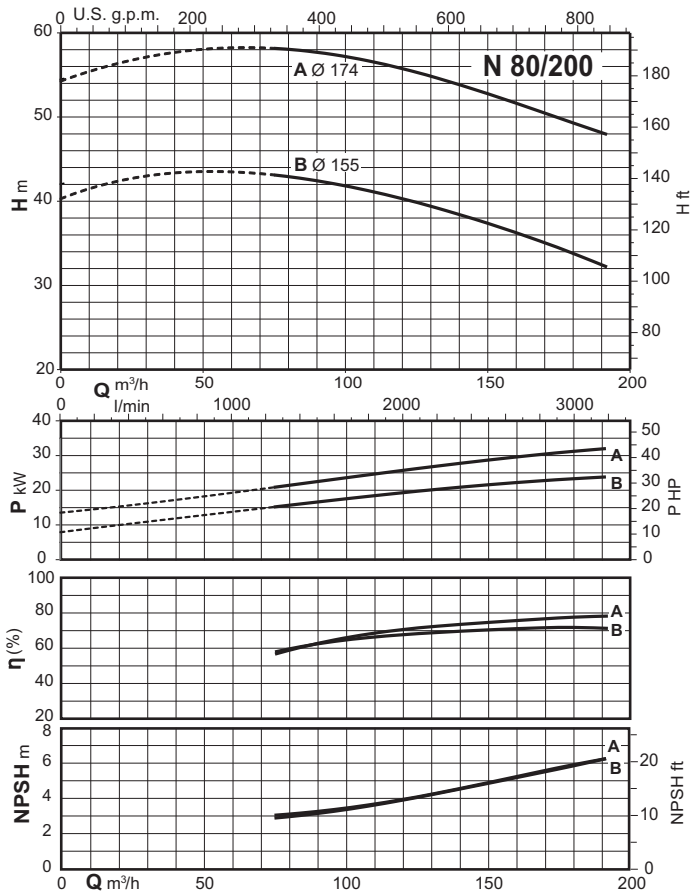
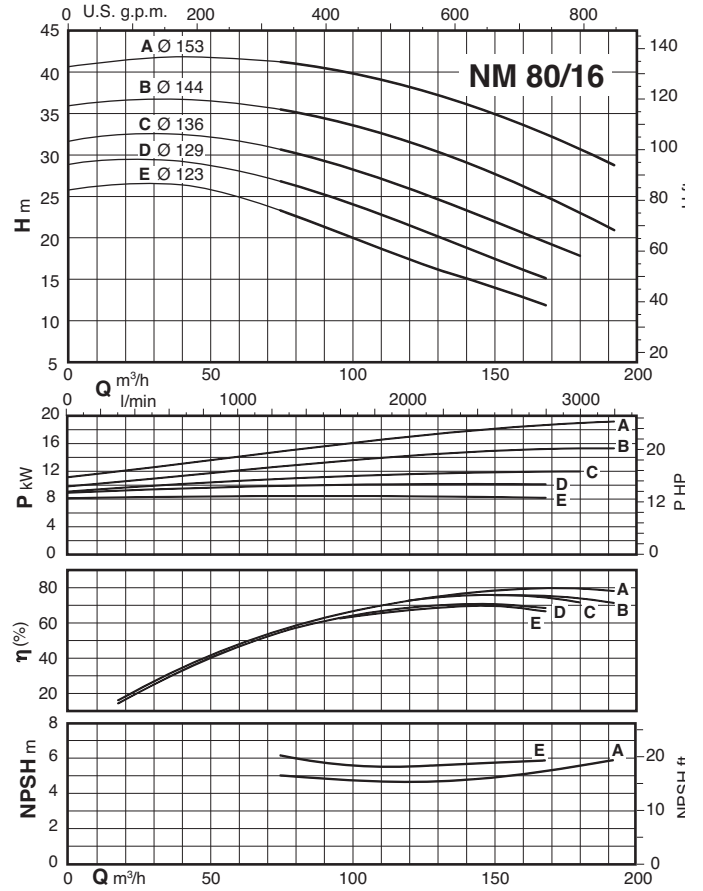
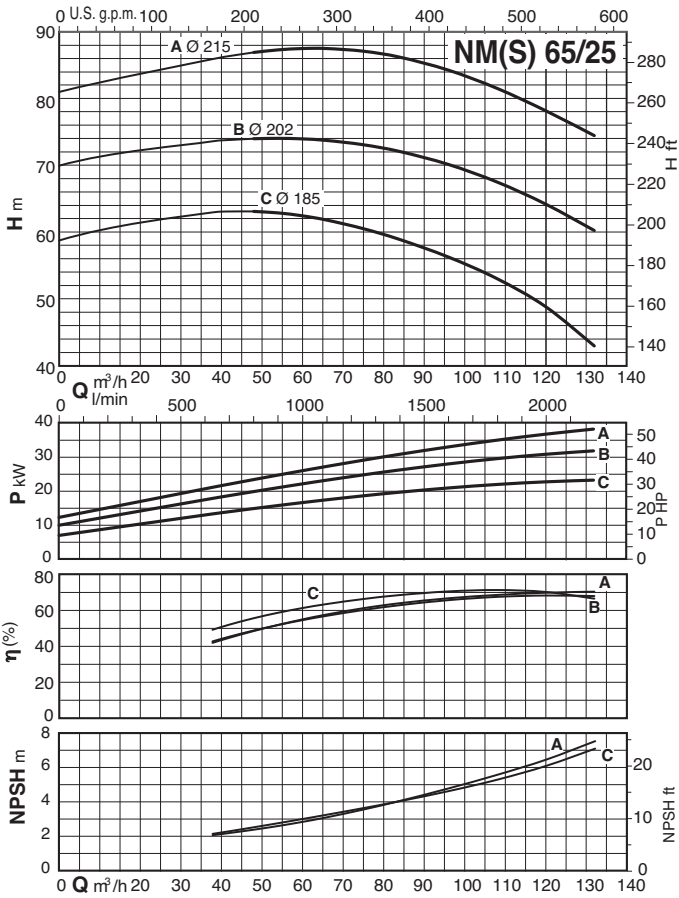

Characteristic curves - Curvas Características

$n \approx 3450$ rpm

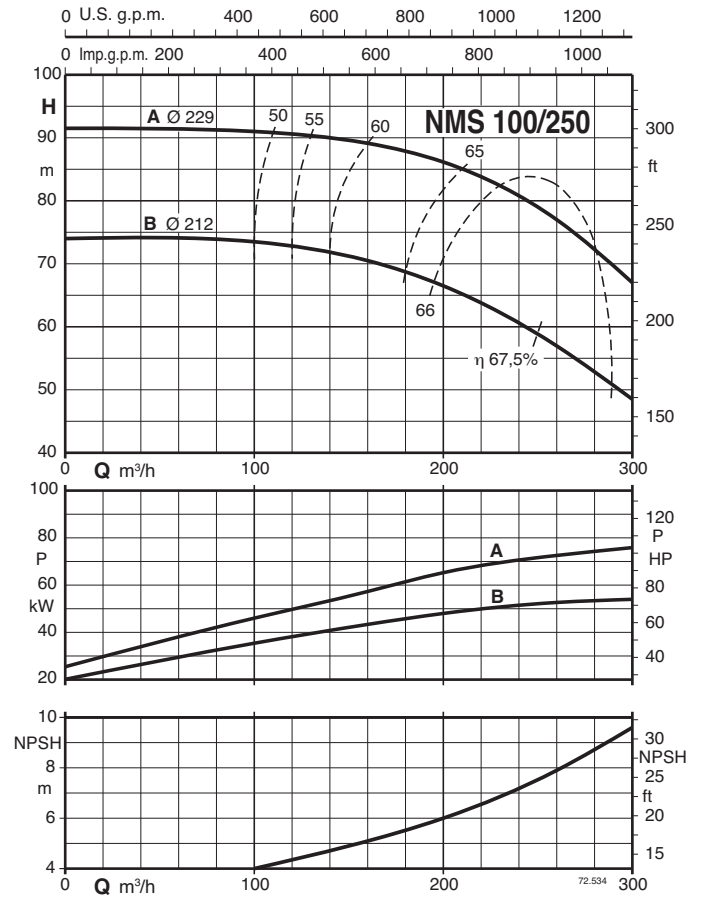
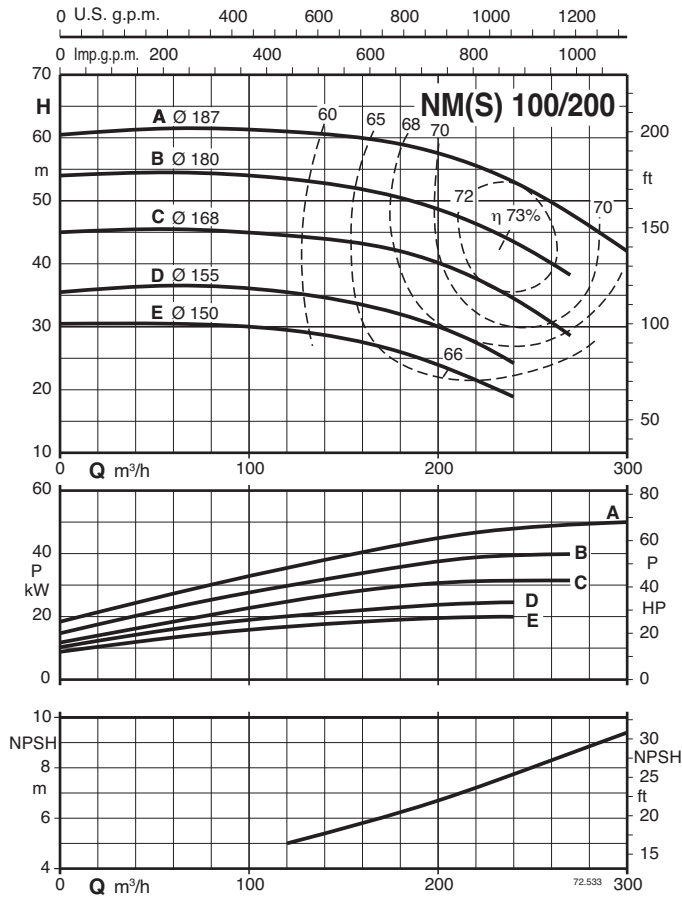

Dimensions and weights - Dimensiones y pesos

Flanges - Bidas EN 1092-2

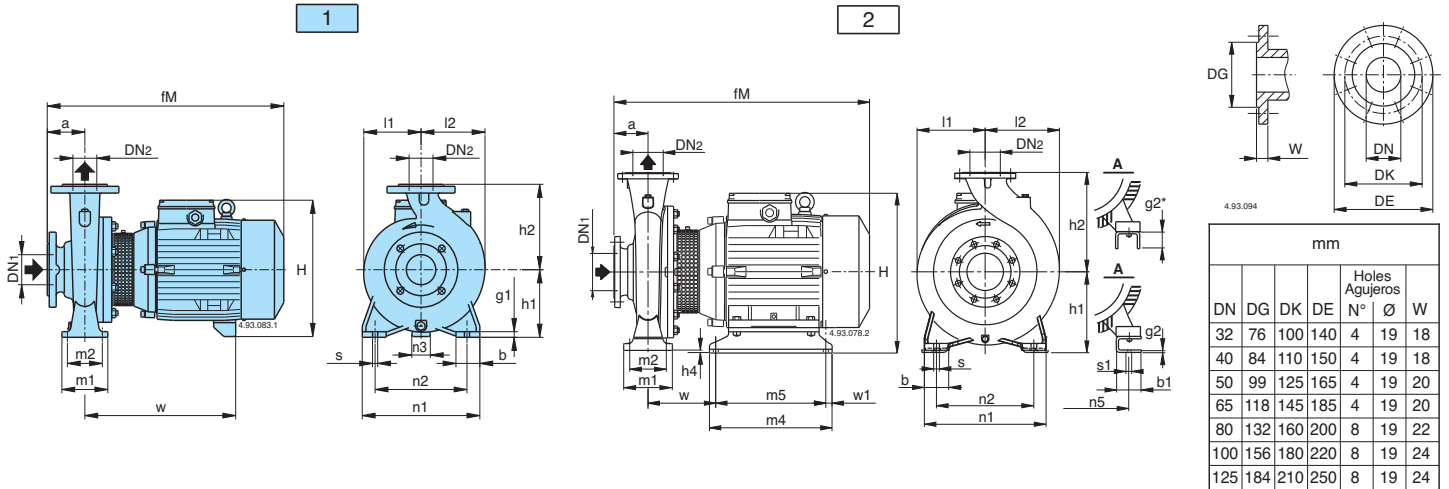

Picture Figura	NM	mm																				kg							
		DN1	DN2	a	fm	h1	h2	H	h4	m1	m2	n1	n2	n3	n5	w1	b	b1	s	s1	l1		l2	w	m4	m5	g1	g2	
1	NM 32/12DE-60, FE-60 NM 32/12S-60/A, A-60/A	50	32	80	405	112	140	240	-	100	70	190	140	37	-	-	50	-	14	-	93	97	245	-	-	12	-	24-24 27-26	
	NM 32/16B-60/A NM 32/16A-60/B	50	32	80	410 450	132	160	260	-	100	70	240	190	47	-	-	50	-	14	-	120	120	250 290	-	-	12	-	34 39	
	NM 32/20D-60/B NM 32/20C-60/A NM 32/20A-60/B	50	32	80	450 475 475	160	180	288 298 298	-	100	70	240	190	62 60 60	-	-	50	-	14	-	140	140	290 295 295	-	-	12	-	42 47 51	
	NM 32L/16C-60 NM 32L/16B-60 NM 32L/16A-60	50	32	80	450 475 475	132	160	260 270 270	-	100	70	240	190	47 45 45	-	-	50	-	14	-	121	121	290 295 295	-	-	10	-	38,6 45,6 47,6	
	NM 32L/20C-60 NM 32L/20A-60, B-60	50	32	80	475 508	160	180	298 320	-	100	70	240	190	60 49	-	-	50	-	14	-	142	142	295 279	-	-	12	-	52 72-66	
	NM 40/12C-60/B, F-60/B NM 40/12A-60/C	65	40	80	410 450	112	140	240	-	100	70	210	160	37	-	-	50	-	14	-	100	113	250 290	-	-	12	-	29-27 32	
	NM 40/16C-60/C NM 40/16B-60/B NM 40/16A-60/C	65	40	80	450 475 475	132	160	260 270 270	-	100	70	240	190	47 45 45	-	-	50	-	14	-	121	122	290 295 295	-	-	10	-	39 46 48	
	NM 40/20C-60/B NM 40/20A/-60A, AR-60/A, B-60/A	65	40	100	495 528	160	180	298 320	-	100	70	265	212	60 49	-	-	50	-	14	-	142	142	295 279	-	-	12	-	54-53 73-67-67	
	NM 40/25C-60/C NM 40/25B-60/C NM 40/25A-60/C	65	40	100	640 690 715	180	225	365	-	125	95	320	250	50	-	-	65	-	14	-	175	175	400 460 460	-	-	15	-	108 117 139	
	NM 50/12F-60/C NM 50/12D-60/B NM 50/12A-60/C	65	50	100	470 495 495	132	160	260 270 270	-	100	70	240	190	47 45 45	-	-	50	-	14	-	122	137	290 295 295	-	-	10	-	40 47 50,5-50,6	
	NM 50/16A-60/B, B-60/B NM 50/20B-60/C NM 50/20A-60/C	65	50	100	528 640 690	160	200	320 345 345	-	100	70	265	212	40	-	-	50	-	14	-	140	153	279 400 460	-	-	15	-	70,5-64 100 109	
	NM 50/25C-60/C NM 50/25B-60/C	65	50	100	695 720	180	225	365	-	125	95	320	250	50	-	-	65	-	14	-	175	175	465 465	-	-	15	-	122 145	
	2	NM 50/25A-60/D	65	50	100	766	180	225	386	-	125	95	320	250	-	254	20	65	60	14	15	175	175	166	394	354	-	20*	-
	1	NM 65/12E-60/C NM 65/12A-60/B, C-60/B	80	65	100	500 533	160	180	298 320	-	125	95	280	212	60 49	-	-	65	-	14	-	130	154	300 284	-	-	12	-	51,9 70,7-64,7
		NM 65/16D-60/B NM 65/16C-60/C NM 65/16B-60/C NM 65/16A-60/C, AR-60	80	65	100	528 640 690 715	160	200	320 345 345 345	-	125	95	280	212	49 40 40 40	-	-	65	-	14	-	140	161	279 410 410 460	-	-	12	-	70,5 93 112 127
		NM 65/20C-60/C	80	65	100	715	180	225	365	-	125	95	320	250	50	-	-	65	-	14	-	159	179	460	-	-	12	-	134
2		NM 65/20A-60/A, B-60/D NM 65/25C-60/A	80	65	100	762 762	180 202	225 250	386 408	-	125	95	320 360	250 280	-	254	20	65	60	14	15	159 179	175	394 400	354 360	-	20* 42*	-- 187	
1		NM 80/16E-60/B NM 80/16D-60/C NM 80/16C-60/C NM 80/16B-60/C	100	80	125	553 670 720 745	180	225	340 365 365 365	-	125	95	320	250	60 50 50 50	-	-	65	-	14	-	153	181	279 415 415 465	-	-	12	-	77,5 101 120 132
2	NM 80/16A-60/D NM 80/20B-60/A NM 80/25E-60 NM 100/20D-60, E-60/A	100	80	125	789 787 787 787	180 202	225 250 280	386 408 408	-	125	95	320 345 400	250 280 315	-	254	20	65	60	14	15	153 170 191	181 194 210	164 182 182	394 400 400	354 360 360	-	20* 42* 42*	-- 180 193	

Pumps with packed gland, dimensions available on request (excluded NMS).
Bombas con prensa estopas, dimensiones bajo demanda (excluidos NMS).

Dimensions and weights - Dimensiones y pesos

Flanges - Bridas EN 1092-2

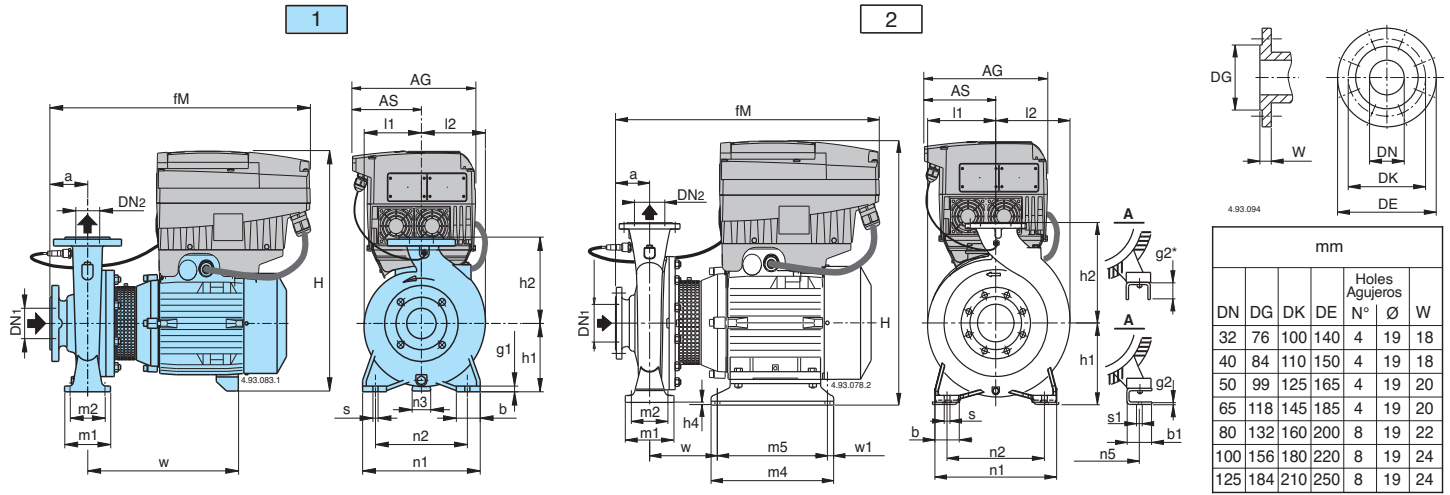

mm						
DN	DG	DK	DE	Holes N°	Ø	W
32	76	100	140	4	19	18
40	84	110	150	4	19	18
50	99	125	165	4	19	20
65	118	145	185	4	19	20
80	132	160	200	8	19	22
100	156	180	220	8	19	24
125	184	210	250	8	19	24

Picture Figura	NM EI	mm																								kg						
		DN1	DN2	a	fM	AG	AS	h1	h2	H	h4	m1	m2	n1	n2	n3	n5	w1	b	b1	s	s1	l1	l2	w		m4	m5	g1	g2		
1	NM EI 32/12DE-60,FE-60 NM EI 32/12S-60/A,A-60/A	50	32	80	435	190	105	112	140	398	-	100	70	190	140	37	-	-	50	-	14	-	93	97	245	-	-	12	-	30,4-30,4 32,4-33,4		
	NM EI 32/16B-60/A NM EI 32/16A-60/B	50	32	80	440 470	190 210	105 118	132	160	418	-	100	70	240	190	47	-	-	50	-	14	-	120	120	250 290	-	-	12	-	40,4 46,5		
	NM EI 32/20D-60/B NM EI 32/20C-60/A NM EI 32/20A-60/B	50	32	80	470 485	210	118	160	180	446 454	-	100	70	240	190	60 60	-	-	50	-	14	-	140	140	290 295	-	-	12	-	49,5 54,5 59		
	NM EI 32L/16C-60 NM EI 32L/16B-60 NM EI 32L/16A-60	50	32	80	470 485	210	118	132	160	418 426	-	100	70	240	190	47 45	-	-	50	-	14	-	121	121	290 295	-	-	10	-	46,1 53,1 55,6		
	NM EI 32L/20C-60 NM EI 32L/20B-60 NM EI 32L/20A-60	50	32	80	485 508 515	210 281	118 153	160	180	454 482	-	100	70	240	190	60 49	-	-	50	-	14	-	142	142	279 279	-	-	12	-	60 74 86,8		
	NM EI 40/12C-60/B,F-60/B NM EI 40/12A-60/C	65	40	80	440 470	190 210	105 118	112	140	398	-	100	70	210	160	37	-	-	50	-	14	-	100	113	250 290	-	-	12	-	33,4-35,4 39,5		
	NM EI 40/16C-60/C NM EI 40/16B-60/B NM EI 40/16A-60/C	65	40	80	470 485	210	118	132	160	418 426	-	100	70	240	190	47 45	-	-	50	-	14	-	121	122	290 295	-	-	10	-	46,5 53,5 56		
	NM EI 40/20C-60/B NM EI 40/20AR-60/A,B-60/A NM EI 40/20A-60/A	65	40	100	505 528 535	210 281	118 153	160	180	454 482	-	100	70	265	212	60 49	-	-	50	-	14	-	142	142	295 279	-	-	12	-	61-62 75-75 87,8		
	NM EI 40/25C-60/C NM EI 40/25B-60/C NM EI 40/25A-60/C	65	40	100	640 690 738	281 281	153 190	180	225	573 573 651	-	125	95	320	250	50	-	-	65	-	14	-	175	175	400 460	-	-	15	-	122,8 131,8 166,8		
	NM EI 50/12F-60/C NM EI 50/12D-60/B NM EI 50/12A-60/C	65	50	100	490 505	210	118	132	160	418 426	-	100	70	240	190	47 45	-	-	50	-	14	-	122	137	290 295	-	-	10	-	47,5 54,5 57-57		
	NM EI 50/16B-60/B NM EI 50/16A-60/B	65	50	100	528 535	281	153	160	180	482 528	-	100	70	265	212	49	-	-	50	-	14	-	126	140	279	-	-	12	-	72 85,3		
	NM EI 50/20B-60/C NM EI 50/20A-60/C	65	50	100	640 690	281 281	153 190	160	200	553 553	-	100	70	265	212	40	-	-	50	-	14	-	140	153	400 460	-	-	15	-	114,8 123,8		
	NM EI 50/25C-60/C NM EI 50/25B-60/C	65	50	100	695 743	281 350	153 190	180	225	533 651	-	125	95	320	250	50	-	-	65	-	14	-	175	175	465 465	-	-	15	-	136,8 180		
	2	NM EI 50/25A-60/D	65	50	100	769	350	190	180	225	671	-	125	95	320	250	-	254	20	65	60	14	15	175	175	166	394	354	15	20*	-	
	1	NM EI 65/12E-60/C NM EI 65/12C-60/B NM EI 65/12A-60/B	80	65	100	510 533 540	210 281	118 153	160	180	482 528	-	125	95	280	212	60 49	-	-	65	-	14	-	130	154	300 284	-	-	12	-	59,9 72,7 85,5	
		NM EI 65/16D-60/B NM EI 65/16C-60/C NM EI 65/16B-60/C NM EI 65/16A-60/C, AR-60	80	65	100	528 640	281 281	153 190	160	200	582 553	-	125	95	280	212	49 40	-	-	65	-	14	-	140	161	279 410	-	-	12	-	85,3 107,8 126,8 162	
		NM EI 65/20C-60/C	80	65	100	738	350	190	180	225	651	-	125	95	320	250	50	-	-	65	-	14	-	159	179	460	-	-	12	-	171	
		2	NM EI 65/20A-60/A, B-60/D NM EI 65/25C-60/A	80	65	100	765	350	190	180	225	671	-	125	95	320	250	-	254	20	80	60	14	15	155	175	175	394	354	-	20*	--
		1	NM EI 80/16E-60/B NM EI 80/16D-60/C NM EI 80/16C-60/C NM EI 80/16B-60/C	100	80	125	555 670 720	281 281	153 190	180	225	548 573	-	125	95	320	250	60 50	-	-	65	-	14	-	165	193	279 415	-	-	15	-	92,3 115,8 134,8
			2	NM EI 80/16A-60/D NM EI 80/20B-60/A NM EI 80/25E-60	100	80	125	792 790	350	190	180	225	671	-	125	95	345	280	-	254	20	80	60	18	14	170	194	164	394	354	-	20*
	NM EI 100/20D-60, E-60/A		125	100	125	790	350	190	200	280	693	-	160	120	360	280	-	254	20	80	60	18	14	191	210	182	400	360	-	42*	228	
	2		NM EI 100/20D-60, E-60/A	125	100	125	790	350	190	200	280	693	-	160	120	360	280	-	254	20	80	60	18	14	191	210	182	394	354	-	40*	--

Dimensions and weights - Dimensiones y pesos

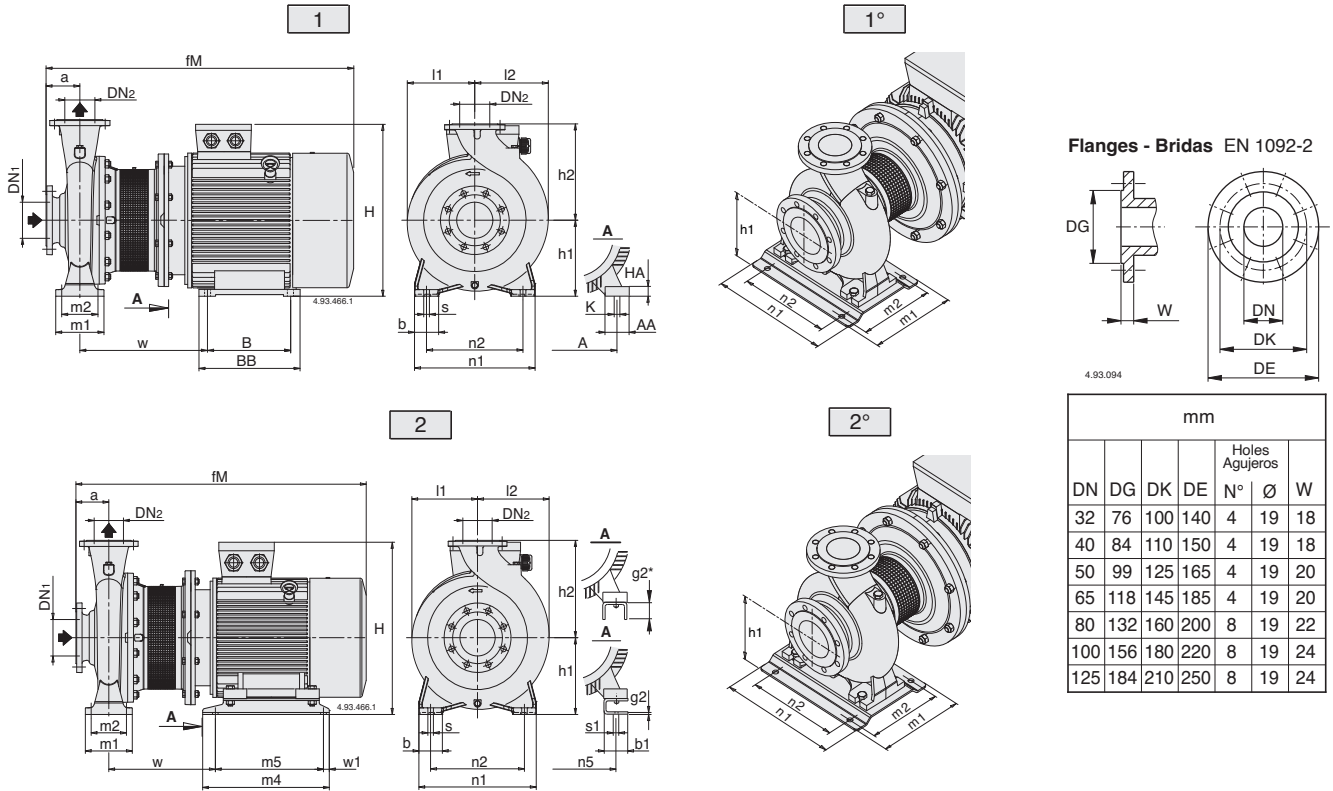

Picture Figura	NMS	mm																										kg			
		DN1	DN2	a	fM	h1	h2	H	m1	m2	n1	n2	A	n5	w1	b	AA	b1	s	K	s1	l1	l2	w	BB	m4	B		m5	HA	g2
2	NMS 65/250B-60/A	80	65	100	961	200	250	486	160	120	360	280	-	279	20	80	-	70	18	-	15	179	195	333	-	440	-	400	-	20	236
1	NMS 65/250A-60/B	80	65	100	1009	200	250	515	160	120	360	280	318	-	-	80	70	-	18	19	-	200	200	406	355	-	305	-	25	-	321
1	NMS 80/200A-60/A	100	80	125	986	180	250	466	125	95	345	280	279	-	-	65	65	-	14	19	-	170	194	394	328	-	279	-	20	-	222
2	NMS 80/250D-60	100	80	125	986	200	280	486	160	120	400	315	-	279	20	80	-	70	18	-	15	191	211	333	-	440	-	400	-	20	242
1	NMS 80/250C-60/A	100	80	125	1034	200	280	515	160	120	400	315	318	-	-	80	70	-	18	19	-	200	210	406	355	-	305	-	25	-	345
1°	NMS 80/250B-60/A	100	80	125	1129	225	280	563	298	258	410	315	356	-	-	-	-	18	19	-	225	225	445	361	-	311	-	34	-	437	
2°	NMS 80/250A-60/A	100	80	125	1198	280	280	690	260	220	410	315	-	406	25	-	-	100	18	-	24	275	275	443	-	500	-	450	-	8	534
2	NMS 100/200C-60	125	100	125	986	200	280	486	160	120	360	280	-	279	20	80	-	70	18	-	15	180	212	333	-	440	-	400	-	20	236
1	NMS 100/200B-60/A	125	100	125	1034	200	280	515	160	120	360	280	318	-	-	80	70	-	18	19	-	200	212	406	355	-	305	-	25	-	338
1°	NMS 100/200A-60/A	125	100	125	1129	225	280	563	298	258	410	315	356	-	-	-	-	18	19	-	225	225	445	361	-	311	-	34	-	426	
2°	NMS 100/250B-60/A	125	100	140	1213	280	280	690	260	220	410	315	-	440	25	-	-	100	18	-	24	275	275	443	-	500	-	450	-	8	545
1°	NMS 100/250A-60/A	125	100	140	1286	280	280	713	260	220	410	315	457	-	-	-	-	100	18	24	-	275	275	516	479	-	368	-	40	-	648

Dimensions and weights - Dimensiones y pesos

Flanges - Bridas EN 1092-2

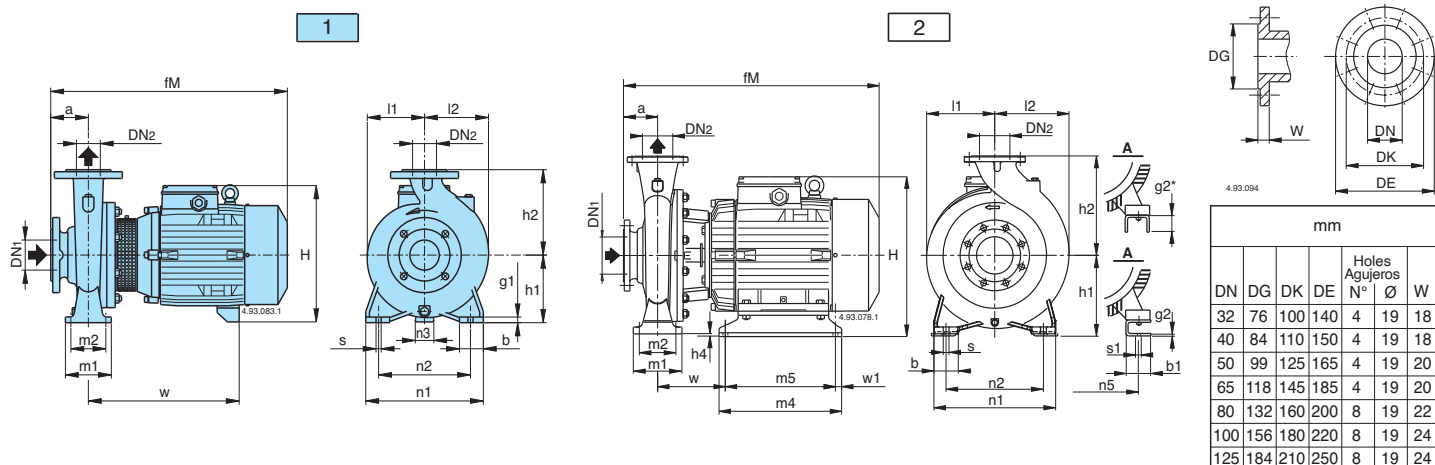

Picture Figura	B- NM	mm																						kg				
		DN1	DN2	a	fM	h1	h2	H	h4	m1	m2	n1	n2	n3	n5	w1	b	b1	s	s1	l1	l2	w	m4	m5	g1	g2	B-NM
1	B-NM 32/12D-60, F-60 B-NM 32/12S-60/A, A-60/A	50	32	80	405	112	140	240	-	100	70	190	140	37	-	-	50	-	14	-	93	97	245	-	-	12	-	27-27 30-28
	B-NM 32/16B-60/A B-NM 32/16A-60/B	50	32	80	410 450	132	160	260	-	100	70	240	190	47	-	-	50	-	14	-	120	120	250 290	-	-	12	-	38,5 42
	B-NM 32/20D-60/B B-NM 32/20C-60/A B-NM 32/20A-60/B	50	32	80	450 475 475	160	180	288 298 298	-	100	70	240	190	45 60 60	-	-	50	-	14	-	140	140	290 295 295	-	-	12	-	47,5 56,5 58
	B-NM 32L/16C-60 B-NM 32L/16B-60 B-NM 32L/16A-60	50	32	80	450 475 475	132	160	260 270 270	-	100	70	240	190	47 45 45	-	-	50	-	14	-	121	121	290 295 295	-	-	10	-	42,5 49,5 52,5
	B-NM 32L/20C-60 B-NM 32L/200A-60,B-60	50	32	80	475 563	160	180	298 320	-	100	70	240	190	60 49	-	-	50	-	14	-	142	142	295 334	-	-	12	-	58,3 79,3-73,8
1	B-NM 40/12C-60/A, F-60/A B-NM 40/12A-60/B	65	40	80	410 450	112	140	240	-	100	70	210	160	37	-	-	50	-	14	-	100	113	250 290	-	-	12	-	33-31 36
	B-NM 40/16C-60/B B-NM 40/16B-60/A B-NM 40/16A-60/B	65	40	80	450 475 475	132	160	260 270 270	-	100	70	240	190	47 45 45	-	-	50	-	14	-	121	122	290 295 295	-	-	10	-	43 50 53
	B-NM 40/20C-60/B B-NM 40/200A-60/A-AR-60/A-B-60/A	65	40	100	495 583	160	180	298 320	-	100	70	265	212	60 49	-	-	50	-	14	-	142	142	295 334	-	-	12	-	59,5-59 80,5-75
2	B-NM 4025/C-60/C B-NM 4025/B-60/C B-NM 4025/A-60/C	65	40	100	635 685 710	192	225	377	12	125	95	320	250	-	216	20	65	69	14	12	175	175	174	298	258	-	6	124 130 159,5
	B-NM 50/12F-60/B B-NM 50/12D-60/A B-NM 50/12A-60/B	65	50	100	470 495 495	132	160	260 270 270	-	100	70	240	190	47 45 45	-	-	50	-	14	-	122	137	290 295 295	-	-	10	-	44 52 54,5-54
	B-NM 50/160A-60/B,B-60/B	65	50	100	583	160	180	320	-	100	70	265	212	49	-	-	50	-	14	-	126	140	334	-	-	12	-	80-74,5
2	B-NM 50/200B-60/C B-NM 50/200A-60/C	65	50	100	695 745	192	200	377	32	100	70	265	212	-	216	20	50	69	14	12	140	153	234	298	258	-	6	123 132
	B-NM 5025/C-60/C B-NM 5025/B-60/C	65	50	100	685 710	192	225	377	12	125	95	320	250	-	216	20	65	69	14	12	175	175	174	298	258	-	6	135 156
	B-NM 50/25A-60	65	50	100	766	180	225	386	-	125	95	320	250	-	254	20	65	60	14	15	175	175	166	394	354	-	20*	-
1	B-NM 65/12E-60/A	80	65	100	500	160	180	298	-	125	95	280	212	60	-	-	65	-	14	-	130	154	300	-	-	12	-	57,3
	B-NM 65/125A-60/B-C-60/B	80	65	100	588	160	180	320	-	125	95	280	212	49	-	-	65	-	14	-	130	154	339	-	-	12	-	80,5-74,5
	B-NM 65/160D-60/B B-NM 65/160C-60/C	80	65	100	583 660	160	200	320 345	-	125	95	280	212	49 40	-	-	65	-	14	-	140	179	334 430	-	-	12	-	80,2 101
2	B-NM 65/160B-60/C B-NM 65/160A-60/C,AR-60	80	65	100	745 770	192	200	377	32	125	95	280	212	-	216	20	65	69	14	12	140	179	234	298	258	-	6	140 152
	B-NM 65/200C-60/C	80	65	100	775	192	225	377	12	125	95	320	250	-	216	20	65	69	14	12	159	179	239	298	258	-	6	160
	B-NM 65/250C-60/B	80	65	100	825	202	250	408	2	160	120	360	280	-	254	20	80	90	18	14	179	195	245	400	360	-	42*	210
1*	B-NM 80/160E-60/B B-NM 80/160D-60/C	100	80	125	608 685	180	225	340 365	-	125	95	320	250	60 50	-	-	65	-	14	-	153	181	334 430	-	-	12	-	89,4 109
	B-NM 80/160C-60/C B-NM 80/160B-60/C	100	80	125	775 800	192	225	377	12	125	95	320	250	-	216	20	65	69	14	12	153	181	239	298	258	-	6	149 161
2	B-NM 80/16A-60	100	80	125	789	180	225	386	-	125	95	320	250	-	254	20	65	60	14	15	153	181	164	394	354	-	20*	-

* Version without coupling guard
Versión sin red de seguridad

Dimensions and weights - Dimensiones y pesos

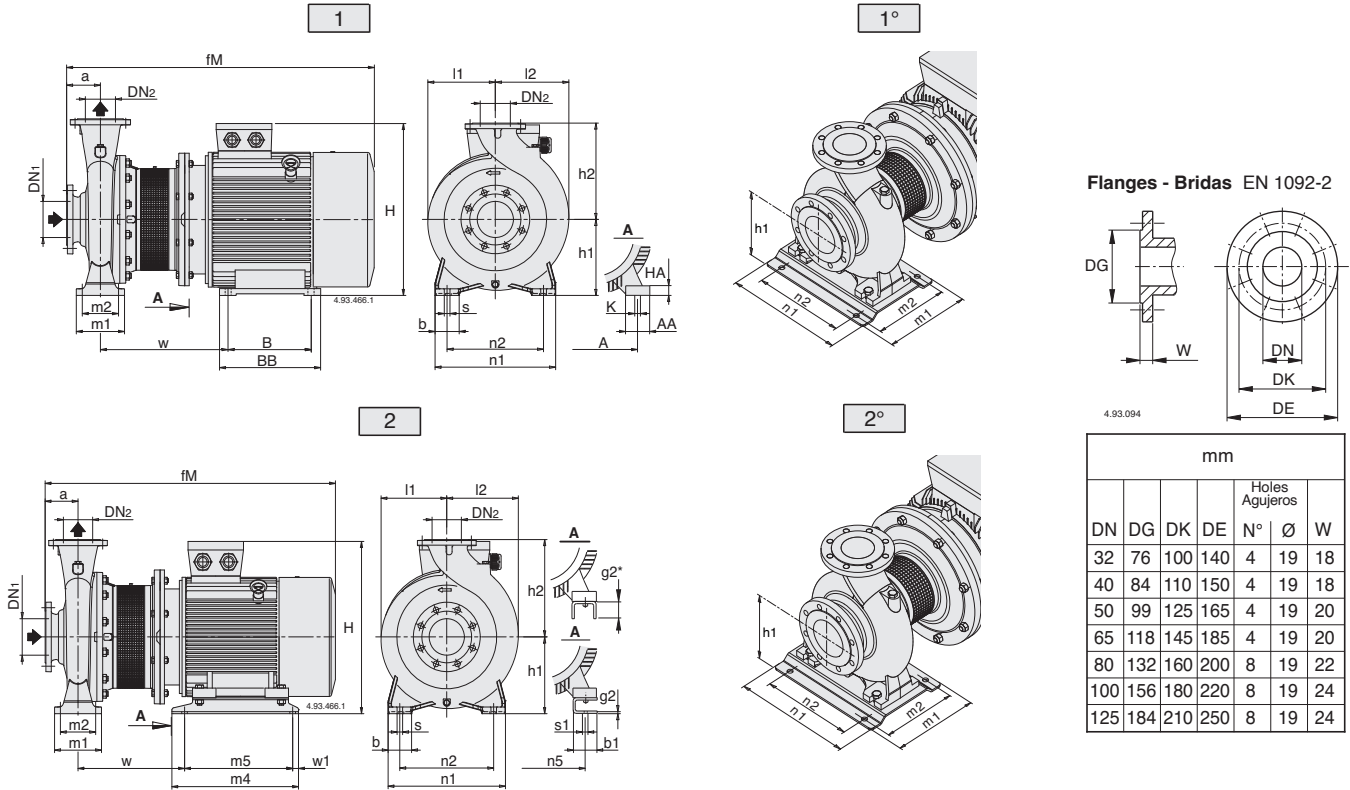

Picture Figura	B-NMS	mm																										kg			
		DN1	DN2	a	fM	h1	h2	H	m1	m2	n1	n2	A	n5	w1	b	AA	b1	s	K	s1	l1	l2	w	BB	m4	B		m5	HA	g2
2	B-NMS 65/200A-60,B-60	80	65	100	864	180	225	386	125	95	320	350	-	254	20	65	-	60	14	-	15	159	179	331	-	394	-	354	-	20	
2	B-NMS 65/250B-60/A	80	65	100	961	200	250	486	160	120	360	280	-	279	20	80	-	70	18	-	15	179	195	333	-	440	-	400	-	20	
1	B-NMS 65/250A-60/B	80	65	100	1009	200	250	515	160	120	360	280	318	-	-	80	70	-	18	19	-	200	200	406	355	-	305	-	25	-	353
2	B-NMS 80/200B-60/B	100	80	125	936	180	250	387	125	95	345	280	-	254	20	65	-	60	14	-	15	175	194	331	-	350	-	310	-	5	
1	B-NMS 80/200A-60/B	100	80	125	986	180	250	466	125	95	345	280	279	-	-	65	65	-	14	15	-	170	194	394	328	-	279	-	20	-	266
2	B-NMS 80/250E-60/A	100	80	125	936	200	280	407	160	120	400	315	-	254	20	80	-	60	18	-	15	191	210	331	-	394	-	354	-	6	
2	B-NMS 80/250D-60/A	100	80	125	986	200	280	486	160	120	400	315	-	279	20	80	-	70	18	-	15	191	212	333	-	440	-	400	-	20	287
1	B-NMS 80/250C-60/A	100	80	125	1034	200	280	515	160	120	400	315	318	-	-	80	70	-	18	19	-	200	210	406	355	-	305	-	25	-	
1°	B-NMS 80/250B-60/A	100	80	125	1129	225	280	563	298	258	410	315	356	-	-	-	80	-	18	19	-	225	225	445	361	-	311	-	34	-	
2°	B-NMS 80/250A-60/A	100	80	125	1198	280	280	690	260	220	410	315	-	406	25	-	-	100	18	-	24	275	275	443	-	500	-	450	-	8	
2	B-NMS 100/200D-60/A,E-60/B	125	100	125	936	200	280	407	160	120	360	280	-	254	20	80	-	60	18	-	15	180	212	331	-	394	-	354	-	6	
2	B-NMS 100/200C-60/A	125	100	125	986	200	280	486	160	120	360	280	-	279	20	80	-	70	18	-	15	180	212	333	-	440	-	400	-	20	
1	B-NMS 100/200B-60/A	125	100	125	1034	200	280	515	160	120	360	280	318	-	-	80	70	-	18	19	-	200	212	406	355	-	305	-	25	-	352
1°	B-NMS 100/200A-60/A	125	100	125	1129	225	280	563	298	258	410	315	356	-	-	-	80	-	18	19	-	225	225	445	361	-	311	-	34	-	
2°	B-NMS 100/250B-60/A	125	100	140	1213	280	280	690	260	220	410	315	-	440	25	-	-	100	18	-	24	275	275	443	-	500	-	450	-	8	
1°	B-NMS 100/250A-60/A	125	100	140	1286	280	280	713	260	220	410	315	457	-	-	-	100	-	18	24	-	275	275	516	479	-	368	-	40	-	

Features - Características constructivas

NM

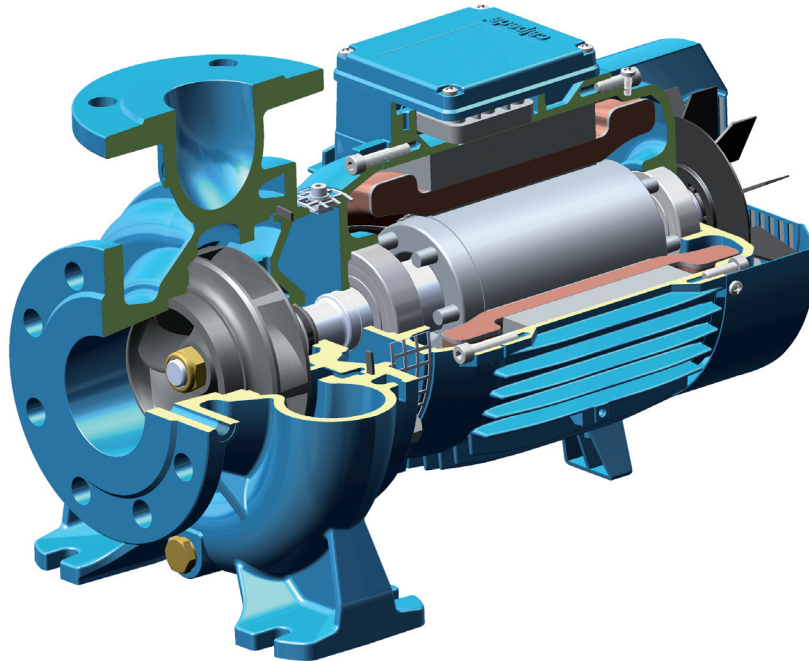

Cutting edge hydraulics

The geometry of the impeller and the pump casing are optimized to achieve maximum efficiency and the best suction capability.

Flexibility

The option to choose between cast iron and bronze materials for the hydraulic parts in contact with the pumped liquid allows NM series pumps to be selected for use with different types of liquids.

Compact Design

The compact design allows for easy installation even in confined spaces.

Exclusive design

An innovative, patented guard prevents contact with rotating parts, proving protection to the end user whilst allowing for inspection of the mechanical seal.

Reliability

The bearing and shaft are designed to ensure the reduction of the stress, providing high reliability under all operating conditions.

Hidráulica de vanguardia

La geometría del impulsor y la carcasa de la bomba han sido mejoradas para conseguir la máxima eficiencia y la mejor capacidad de succión.

Flexibilidad

La opción de poder elegir entre hierro fundido y bronce para las partes hidráulicas en contacto con el bombeo permite que las bombas de la serie NM puedan ser seleccionadas para utilizar con diferentes tipos de líquidos.

Diseño compacto

El diseño compacto permite una fácil instalación incluso en espacios confinados.

Diseño exclusivo

Un innovador protector patentado evita el contacto con las partes rotantes, lo que demuestra la protección para el usuario final mientras le permite la inspección del sello mecánico.

Fiabilidad

El cojinete y el eje están diseñados para asegurar la reducción de la tensión, proporcionando alta fiabilidad en todas las condiciones.

Features - Características constructivas

NMS

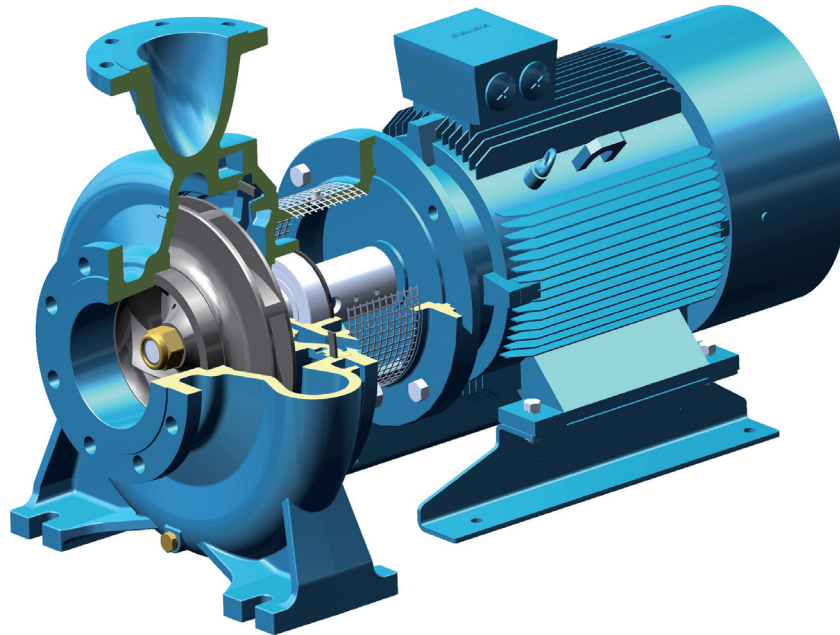

Cutting edge hydraulics

The geometry of the impeller and the pump casing are optimized to achieve maximum efficiency and the best suction capability.

Flexibility

The option to choose between cast iron and bronze materials for the hydraulic parts in contact with the pumped liquid allows NMS series pumps to be selected for use with different types of liquids.

New lantern bracket construction

The lantern brackets incorporate a thrust bearing on the hydraulic side which guarantees the elimination of additional loads on the motor bearings. The flange is sized to be used with standard motors B35.

Exclusive design

An innovative, patented guard prevents contact with rotating parts, proving protection to the end user whilst allowing for inspection of the mechanical seal.

Simplified motor maintenance

The presence of the thrust bearing on the hydraulic side makes it easier to remove the motor, facilitating maintenance operations and eliminating the risks of damage to the hydraulic parts.

Hidráulica de vanguardia

La geometría del impulsor y la carcasa de la bomba han sido mejoradas para conseguir la máxima eficiencia y la mejor capacidad de succión.

Flexibilidad

La opción de poder elegir entre hierro fundido y bronce para las partes hidráulicas en contacto con el bombeo permite que las bombas de la serie NMS puedan ser seleccionadas para utilizar con diferentes tipos de líquidos.

Nuevo acoplamiento

El acoplamiento incorpora un rodamiento de empuje del lateral hidráulico que garantiza la eliminación de cargas en los cojinetes del motor. La brida está dimensionada para utilizarse con motores B35 estándar.

Diseño exclusivo

Un innovador protector patentado evita el contacto con las partes rotantes, lo que demuestra la protección para el usuario final mientras le permite la inspección del sello mecánico.

Mantenimiento del motor simplificado

La presencia del cojinete de empuje en la parte hidráulica hace que sea más fácil quitar el motor, lo que facilita el mantenimiento de operaciones eliminando los riesgos de daños a las piezas hidráulicas.