



Franklin Electric

VSI SERIES 50 Hz

SS CAST SUBMERSIBLE PUMPS 8"-10"-12"



INDEX

Product Overview	3
Features & benefits	3
Family curves	4
General features	4
Pump identification code	5
Impellers configuration	5
Part number identification code	6
Pump configuration	6
Product name plate	6
Parts and material	7
 TECHNICAL DATA AND PERFORMANCE CURVES	
Hydraulic performance 50 Hz	13
VSI 134	13
VSI 184	14
VSI 254	15
VSI 344	16
Dimensions and performance curves 50 Hz	17
VSI 134	17
VSI 184	25
VSI 254	33
VSI 344	43
Motor brackets	50
VSI 8"	50
VSI 10"	51
VSI 12"	52
Counterflanges	53
VSI 10"	53
VSI 12"	53
Cable guards	54
VSI 8"	54
VSI 10"	54
VSI 12"	54
Motor/Pump connection screws	55

PRODUCT OVERVIEW

FEATURES & BENEFITS

APPLICATIONS



Municipal water works



Drainage and dewatering



General industry



Agriculture, Irrigation



Mining industry



Offshore

HIGH EFFICIENCY AND CORROSION RESISTANCE

- High efficiency (up to 85 %)
- Diffusers and impellers made of investment casting stainless steel
- Balanced impellers
- Spring loaded, robust design check valve with two bearing bushings and one-piece valve cone
- Vesconite Hilube® top bearing bush (closed on top)
- PTFE+Graphite up-thrust bearing
- Shrink fit coupling
- Drinking water approvals

Accessories

- Cooling shrouds

OPTIONS



- SD version with second cable guard
- Different impeller diameters for 10" and 12" pump
- Different constructive metallurgies: CF8/304 (I version), CF8M/316 (N version), DUPLEX (R version)
- Cable guard type H (High)

PRODUCT OVERVIEW

FAMILY CURVES

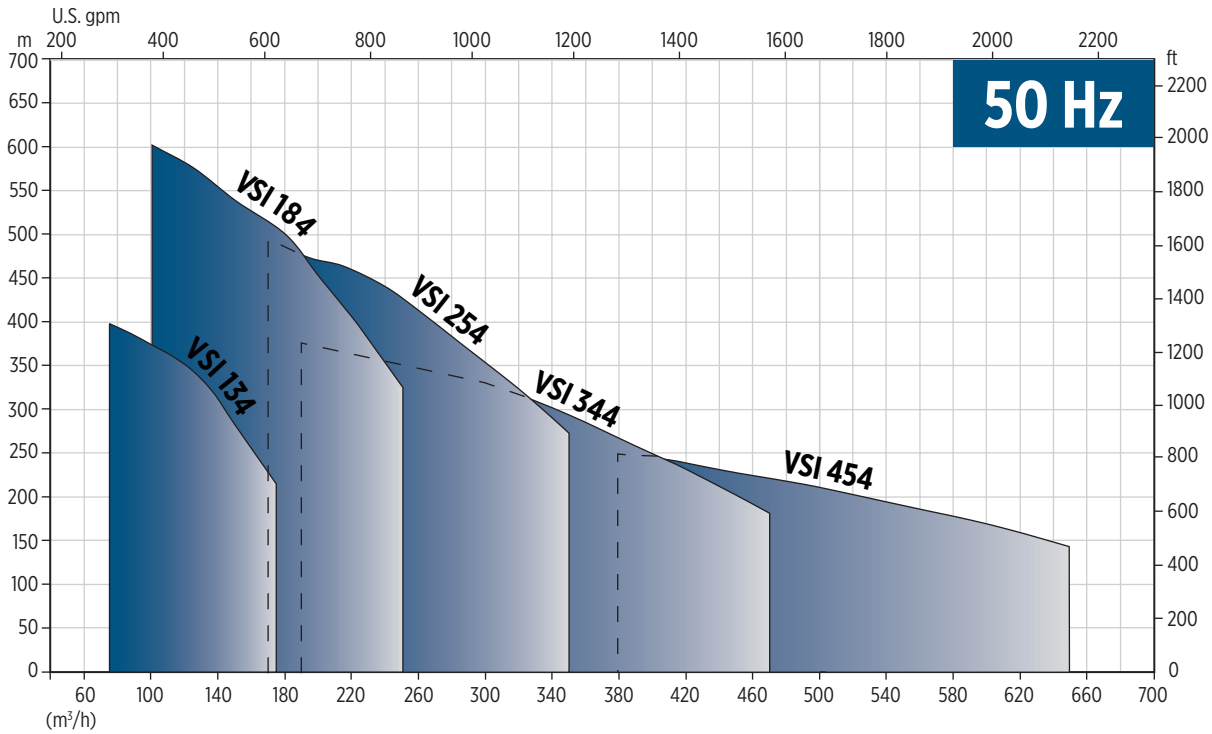

00150052_05/2024

GENERAL FEATURES

Model	8"	10"		12"
	134	184	344	454
Nominal flow [m ³ /h]	133	180 ⁽¹⁾	334	450
Number of stages	1-20	1-16	1-7	1-6
Type of impeller	Semi axial		Semi axial	Semi axial
Max Liquid temperature [°C]	+65 ⁽²⁾			
Hydraulic efficiency [%]	up to 81,8% ⁽¹⁾	up to 83,5% ⁽¹⁾	up to 85% ⁽¹⁾	up to 84% ⁽¹⁾
Range [m ³ /h]	75 - 175	100 - 250 ⁽¹⁾	190 - 490 ⁽¹⁾	320 - 650 ⁽¹⁾
Max. head at minimum flow [m]	398	601	387	250
Shutoff [m]	436	665	433	330
Hydraulic connection (Dimensions)	Rp or NPT 5"	Rp or NPT 6" / Flanged D170 w/o counterflange	Flanged D220 with counterflange	Flanged D220 with counterflange
	PN45	PN65	PN45	PN45
Maximum allowable amount of sand:	100 g/m ³			
Motor power range [kW]:	9,3 - 150	13 - 300	30 - 350	55 - 350
Trimmed impeller diameters:	-	•	•	•
Rotation:	counter clockwise when looking into the discharge			
Operation:	vertical or horizontal position (depends on the paired motor)			
Material versions:	CF8/304 - CF8M/316 - DUPLEX			
Drinking water approvals				

⁽¹⁾ Depending on the selected model

⁽²⁾ Refers to the pump. For electric pumps, please refer to the data table for the motor.

"-" = not available

• = available

PRODUCT OVERVIEW

PUMP IDENTIFICATION CODE

VSI 184 / 04 I / 2B - W R - M8 - 50 D L E - A

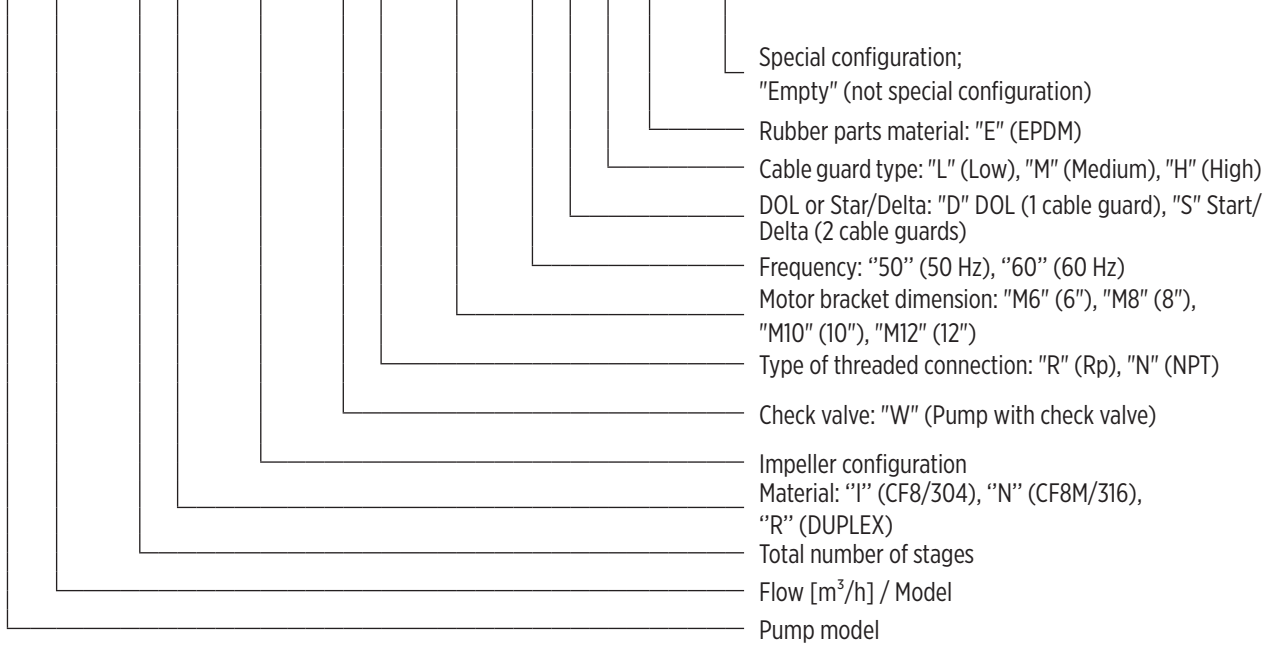

00140090 04/2023

IMPELLER CONFIGURATION

Total number of stages	Impeller configuration	Number of impellers	
		Type B impeller	Standard impeller
4	2B	2	2

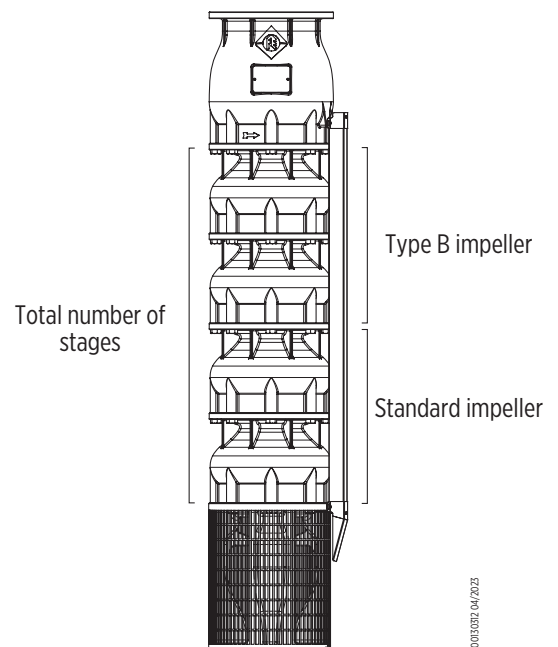

0013032 04/2023

PRODUCT OVERVIEW

PART NUMBER IDENTIFICATION CODE

97A | 0 | 18 | 04 | 07 | 5 | B | 00 | A

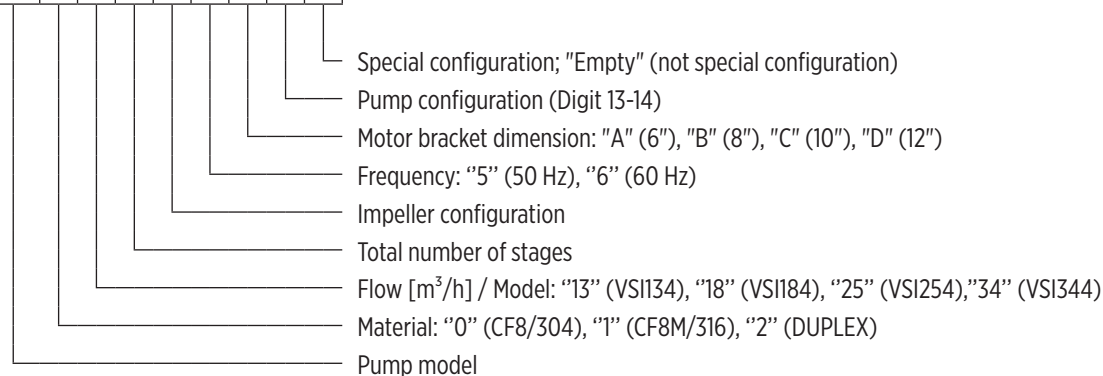

0014009112/2023

PUMP CONFIGURATION

Digit 13-14	Check valve	Type of thread	DOL / SD	Cable guard type	Neck ring material	Bearing material	Diffuser and check valve OR
00	With check valve	RP	DOL	Low	EPDM	EPDM	EPDM
01	With check valve	RP	SD	Low	EPDM	EPDM	EPDM
32	With check valve	RP	DOL	Mid	EPDM	EPDM	EPDM
33	With check valve	RP	SD	Mid	EPDM	EPDM	EPDM

PRODUCT NAME PLATE

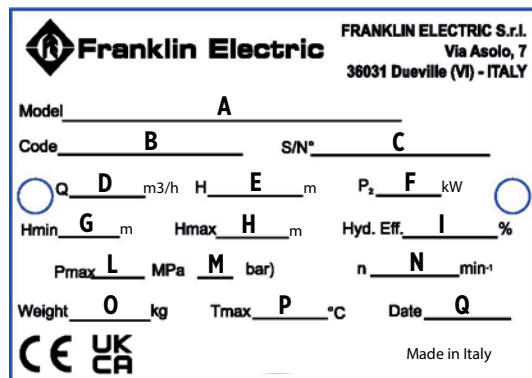

- A) Pump identification code
- B) Product code
- C) Serial number
- D) Operating flow range
- E) Operating head range
- F) Maximum mechanical power absorbed by the pump with rewindable motor
- G) Minimum head
- H) Maximum head
- I) Maximum pump efficiency
- L) Maximum operating pressure [Mpa]
- M) Maximum operating pressure [bar]
- N) Nominal rotation speed with rewindable motor
- O) Pump weight
- P) Maximum temperature of the pumped liquid (excluding industrial uses see below)
- Q) Year of production

0014009204/2023

PARTS AND MATERIAL

PARTS & MATERIAL

Ref. No.	Parts description	Material	Reference standard					
			I version		N version		R version	
			ASTM/AISI	DIN/EN	ASTM/AISI	DIN/EN	ASTM/AISI	DIN/EN
10.00.01	Discharge head	Stainless steel	CF8 (304)	1.4308	CF8M (316)	1.4408	-	1.4517
10.00.02	Valve bearing bush	EPDM	-					
10.01	Valve	Stainless steel	CF8 (304)	1.4308	CF8M (316)	1.4408	-	1.4517
10.06	Valve spring	Stainless steel	2205	1.4462	2205	1.4462	2205	1.4462
10.08	Valve gasket	EPDM	-					
10.09	Valve seat	Stainless steel	CF8M (316)	1.4408	CF8M (316)	1.4408	-	1.4517
10.11	Counter flange	Stainless steel	CF8M (316)	1.4408	CF8M (316)	1.4408	-	1.4517
20.01.01	Suction strainer	Stainless steel	316L	1.4404	316L	1.4404	904L	1.4539
20.01.02	Screws	Stainless steel	316	1.4401	316	1.4401	904L	1.4539
20.02	Cable guard	Stainless steel	316L	1.4404	316L	1.4404	904L	1.4539
20.05.01	Motor bracket	Stainless steel	CF8 (304)	1.4308	CF8M (316)	1.4408	-	1.4517
20.05.02	Neck ring	EPDM	-					
20.05.03	O-Ring	EPDM	-					
20.05.04	Up-thrust ring	PTFE + Graphite	-					
20.05.05	Screws	Stainless steel	316	1.4401	316	1.4401	2205	1.4462
20.05.06	Counter flange screws	Stainless steel	2205	1.4462	2205	1.4462	2205	1.4462
20.06.01	Motor adapter	Stainless steel	CF8M (316)	1.4408	CF8M (316)	1.4408	-	1.4517
20.06.02	Screws	Stainless steel	316	1.4401	316	1.4401	2205	1.4462
20.06.03	Washers	Stainless steel	316	1.4401	316	1.4401	2205	1.4462
20.06.04	Coupling adapter	Stainless steel	2205	1.4462	2205	1.4462	2205	1.4462
20.06.05	Stud bolts	Stainless steel	2205	1.4462	2205	1.4462	2205	1.4462
20.06.06	Washers	Stainless steel	2205	1.4462	2205	1.4462	2205	1.4462
20.06.07	Nuts	Stainless steel	2205	1.4462	2205	1.4462	2205	1.4462
20.07.01	Cable guard top end	Stainless steel	316L	1.4404	316L	1.4404	904L	1.4539
20.07.02	Cable guard bottom end	Stainless steel	316L	1.4404	316L	1.4404	904L	1.4539
30.08.01	Pump shaft	Stainless steel	431	1.4057	329	1.4460	329	1.4460
30.08.02	Coupling	Stainless steel	316	1.4401	316	1.4401	2205	1.4462
40.00.01	Diffuser	Stainless steel	CF8 (304)	1.4308	CF8M (316)	1.4408	-	1.4517
40.00.02	Bearing bush	EPDM	-					
40.04.01	Diffuser cap	Vesconite Hilube®	-					
50.00	Impeller	Stainless steel	CF8 (304)	1.4308	CF8M (316)	1.4408	-	1.4517
50.01	Taper lock	Stainless steel	316	1.4401	316	1.4401	329	1.4460

PARTS AND MATERIAL

VSI 8"

PUMP WITH 8" MOTOR

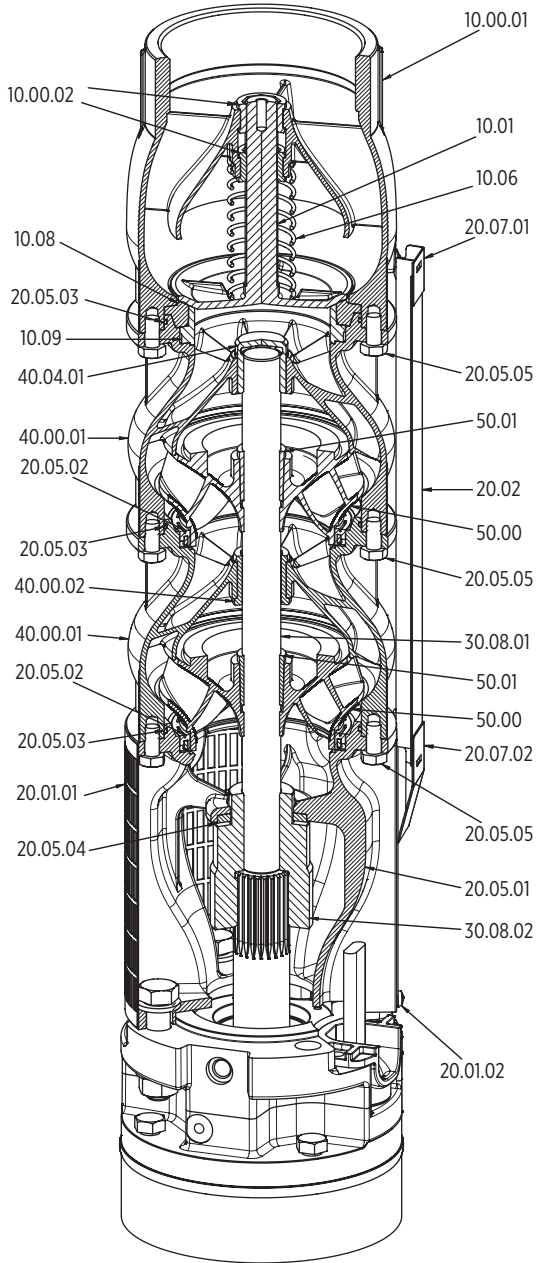

PUMP WITH 6" MOTOR

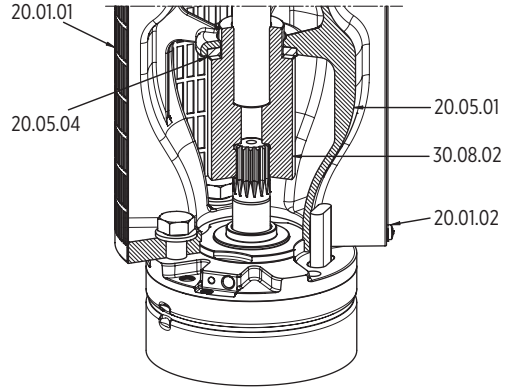

PUMP WITH 10" MOTOR

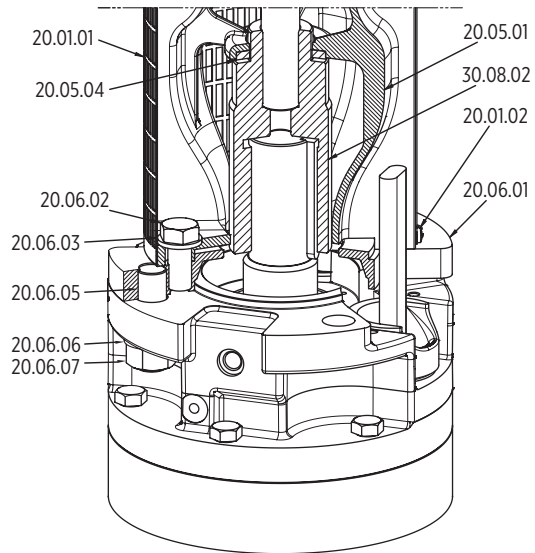

00153514 05/2023

PARTS AND MATERIAL

VSI 10"

PUMP WITH 10" MOTOR

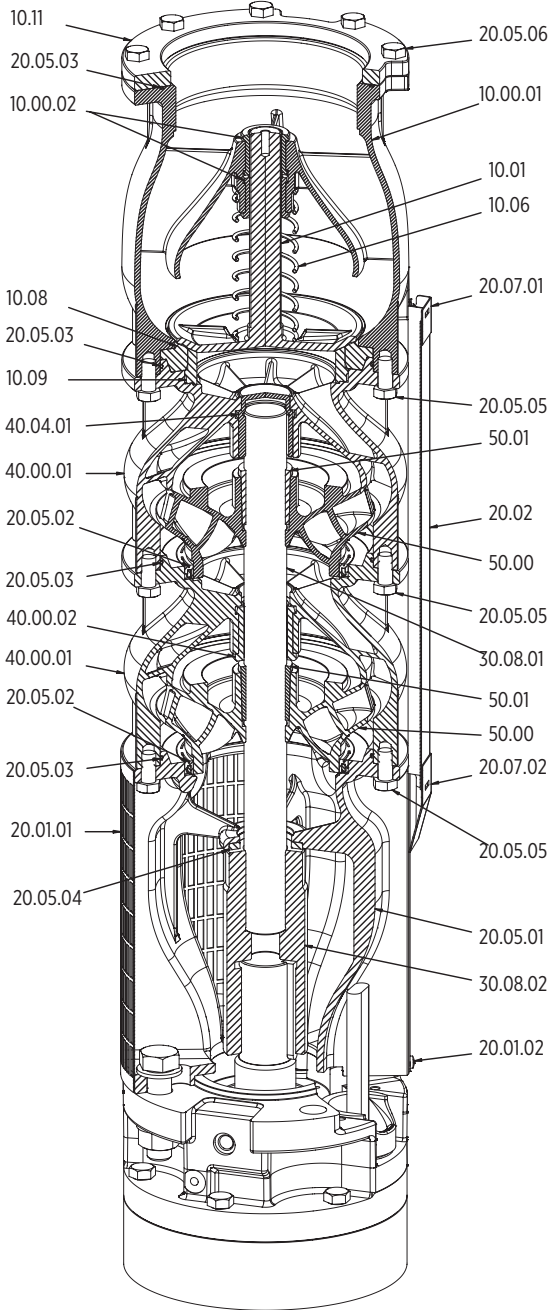

PUMP WITH 6" MOTOR

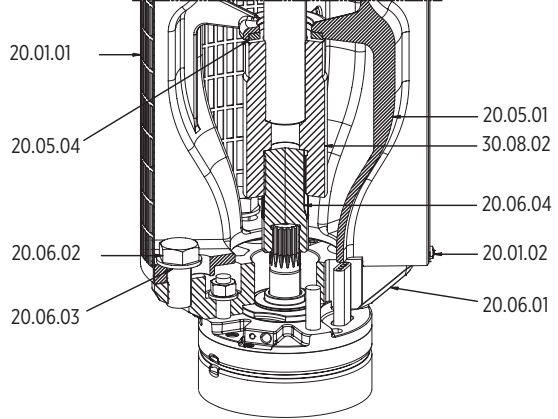

PUMP WITH 8" MOTOR

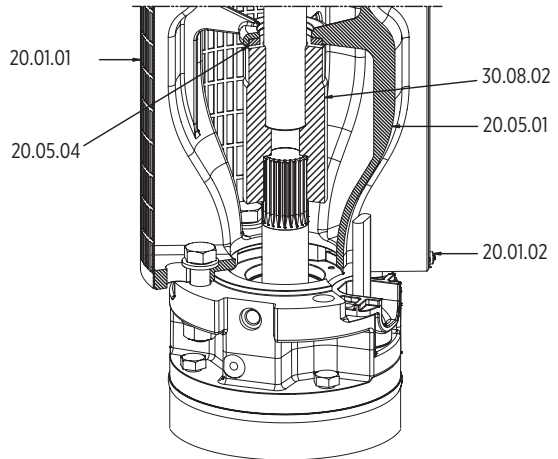

PUMP WITH 12" MOTOR

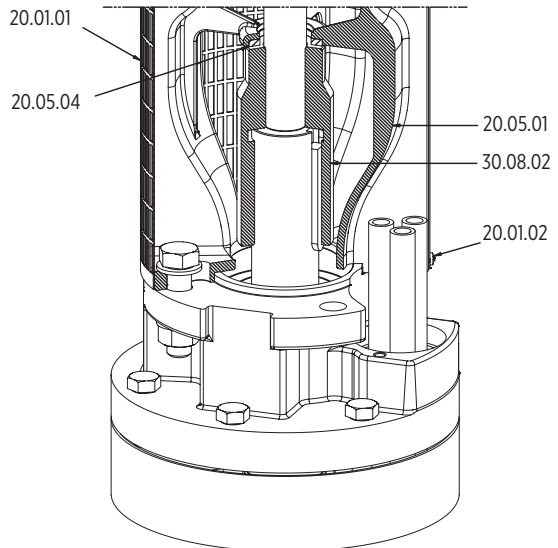

00130307 04/2023

PARTS AND MATERIAL

VSI 12"

PUMP WITH 12" MOTOR

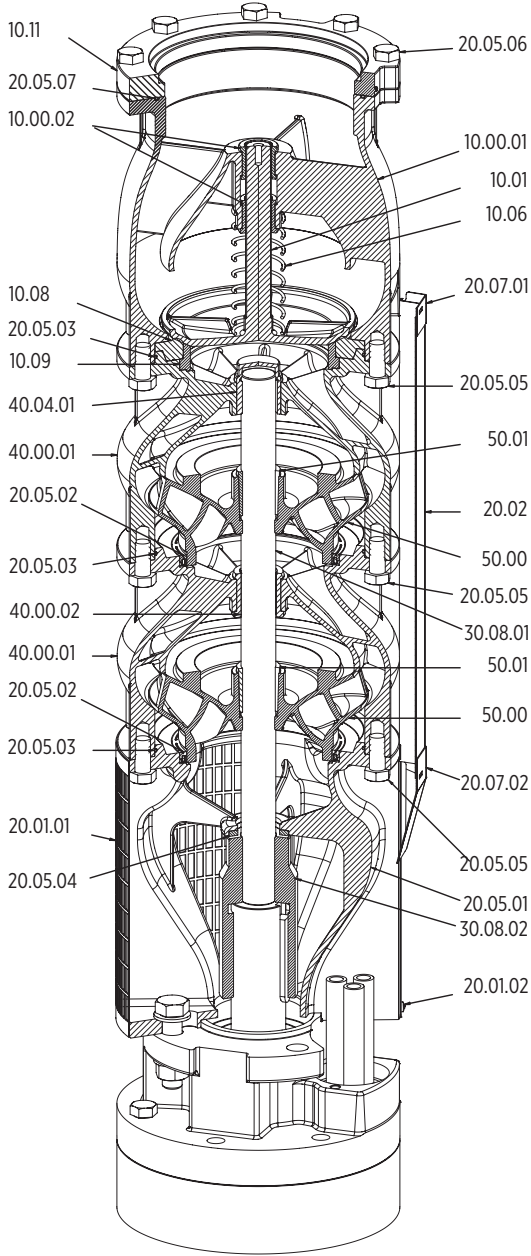

PUMP WITH 8" MOTOR

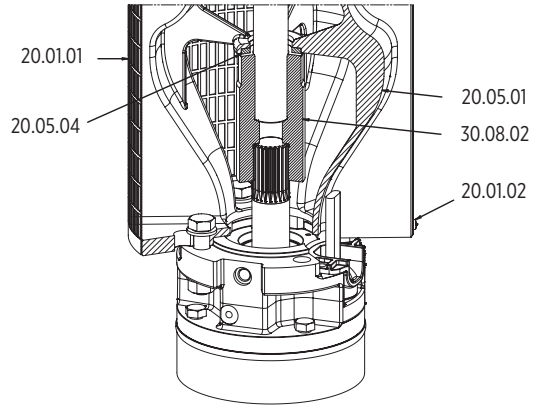

PUMP WITH 10" MOTOR

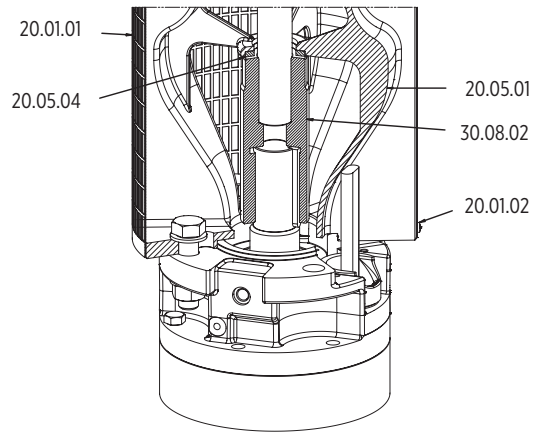

0016607 12/2013

Technical data and performance curves



HYDRAULIC PERFORMANCE 50 Hz

VSI 134

Pump model	Rated power		Q = Delivery												
			m ³ /h 0	25	50	75	87.5	100	112.5	125	137.5	150	162.5	175	190
			l/min 0	416.7	833.3	1250	1458.3	1666.7	1875	2083.3	2291.7	2500	2708.3	2916.7	3166.7
	US gpm	109.9	219.8	329.8	384.7	439.7	494.6	549.6	604.5	659.5	714.5	769.4	835.4		
[kW]	[HP]	H = Total meters head of water column [m]													
VSI134/01	9.3	12.5	23.8	22.4	21.3	18.3	17.7	18.1	18	16.7	14.9	13.5	12	9.4	5.7
VSI134/02	15	20	45.1	43.3	41.3	37.9	36.7	36.3	35.5	33.3	30.3	27	23.6	19.6	13.4
VSI134/03	22	30	66.4	64.3	61.4	57.5	55.8	54.7	53.2	50.2	45.9	40.8	35.5	30.1	21.4
VSI134/04	30	40	88.4	86	82.2	77.9	75.5	73.8	71.6	67.8	62.3	55.4	48.1	41.2	30.4
VSI134/05	37	50	109.6	106.9	102.1	97.4	94.5	92.1	89.2	84.5	77.7	69.1	59.8	51.5	38.2
VSI134/06	45	60	131.6	128.6	122.9	117.7	114.2	111.1	107.5	102.1	94	83.6	72.4	62.6	47.1
VSI134/07	52	70	152.9	149.5	142.9	137.3	133.3	129.5	125.2	118.9	109.6	97.3	84.2	73	55
VSI134/08	60	80	174.8	171.1	163.6	157.5	153	148.5	143.6	136.4	125.9	111.9	96.7	84.1	63.9
VSI134/09	67	90	196.5	192.4	184	177.5	172.3	167.2	161.5	153.5	141.7	125.9	108.8	94.7	72.2
VSI134/10	75	100	217.9	213.5	204.2	197.3	191.7	185.9	179.5	170.7	157.7	140.1	121	105.4	80.6
VSI134/11	83	110	240.5	235.8	225.6	218.3	212.1	205.6	198.6	189	174.9	155.5	134.4	117.2	90.4
VSI134/12	93	125	262.4	257.5	246.4	238.7	232	224.8	217.2	206.8	191.5	170.4	147.2	128.5	99.6
VSI134/13	110	150	284.1	278.9	266.9	259	251.8	244	235.7	224.7	208.2	185.3	160.1	139.8	108.8
VSI134/14	110	150	305.0	299.4	286.5	278	270.3	261.8	252.8	240.8	223	198.2	171.2	149.5	115.8
VSI134/15	130	175	329.3	323.5	309.7	300.8	292.5	283.3	273.6	260.9	242	215.7	186.4	163	128.1
VSI134/16	130	175	350.3	344.1	329.3	319.8	310.9	301	290.5	276.9	256.7	228.5	197.4	172.6	135.1
VSI134/17	130	175	371.2	364.6	348.9	338.8	329.2	318.5	307.3	292.8	271.2	241.1	208.1	182.1	141.8
VSI134/18	150	200	393.3	386.6	370.1	360	350.1	338.9	327.1	311.9	289.3	257.6	222.4	194.6	152.6
VSI134/19	150	200	414.3	407.2	389.8	379.1	368.6	356.6	344.1	328	304	270.4	233.4	204.3	159.6
VSI134/20	150	200	435.2	427.7	409.3	398	386.8	374.1	360.8	343.8	318.5	282.9	244.1	213.7	166.3

HYDRAULIC PERFORMANCE 50 Hz

VSI 184

Pump model	Rated power		Q = Delivery												
			m ³ /h 0	30	65	75	100	125	150	180	200	220	230	250	280
			l/min 0	500	1083,3	1250	1666.7	2083.3	2500	3000	3333.3	3666,7	3833,3	4166,7	4666,7
	US gpm	131,9	285,8	329.8	439.7	549.6	659.5	791.4	879.3	967,3	1011,2	1099,2	1231,1		
[kW]	[HP]	H = Total meters head of water column [m]													
VSI184/01/1B	13	17.5	31,1	29,8	28,8	28,6	26,8	24,6	23,1	19	16,1	13,1	11,4		
VSI184/01	18.5	25	41,7	39,5	37,5	36,9	35,2	32,5	32,2	28,6	25,4	22,1	20,5	16,6	8,6
VSI184/02/2B	26	35	60,7	58,7	56,8	56,6	54,2	50,5	46,4	39,2	33,6	27,6	24,4		
VSI184/02/1B	30	40	71,9	68,9	66	65,5	63,2	59,1	56,1	49,5	43,5	37,3	34,2	27,2	13,8
VSI184/02	37	50	82,8	79,1	75,5	74,8	72,4	68,1	65,4	59,4	53,1	47	43,7	36,7	23,5
VSI184/03/2B	45	60	101,9	98,3	94,5	94	91,2	85,6	80	70,5	61,7	52,5	47,8	37,6	18,4
VSI184/03/1B	52	70	112,9	108,5	104,1	103,4	100,3	94,8	89,3	80,3	71,3	62,3	57,4	47,3	28,3
VSI184/03	55	75	124,2	119,1	113,9	112,9	109,9	103,9	98,7	90,3	81	72	67	56,9	38,2
VSI184/04/2B	60	80	142,5	137,3	132	131,3	127,4	120,7	112,5	100,3	88,4	76,6	70,1	56,9	32
VSI184/04/1B	67	90	153,8	147,9	141,8	140,9	137,1	129,9	121,9	110,4	98,2	86,4	79,9	66,6	42
VSI184/04	75	100	164,9	158,2	151,4	150,3	146,6	139	131,4	120,5	108,2	96,3	89,7	76,5	52,1
VSI184/05/2B	83	110	184,4	177,8	170,9	170,1	165,6	157,3	146,7	132,2	117,3	102,6	94,5	78	47,6
VSI184/05/1B	93	125	195,9	188,5	180,9	179,8	175,5	166,8	156,4	142,8	127,5	112,9	104,6	88,2	58,1
VSI184/05	93	125	206,5	198,4	190	188,6	184,4	175,2	165	151,9	136,4	121,7	113,4	97,1	67,2
VSI184/06/2B	110	150	225,4	217,3	208,8	207,8	202,8	193,1	180	163,3	145,3	127,7	117,9	98,3	62,1
VSI184/06/1B	110	150	236,1	227,2	218	216,7	211,7	201,5	188,7	172,5	154,2	136,7	126,8	107,2	71,3
VSI184/06	110	150	246,6	237,1	227,1	225,5	220,5	209,8	197,3	181,6	163,1	145,6	135,6	116,1	80,5
VSI184/07/2B	130	175	267,7	258,1	248	246,7	241	229,6	213,9	194,8	173,6	153,2	141,8	119	77,5
VSI184/07/1B	130	175	278,4	268	257,1	255,6	249,9	238	222,5	203,8	182,4	162,1	150,5	127,8	86,6
VSI184/07	130	175	289,0	277,9	266,3	264,5	258,7	246,2	231	212,8	191,1	170,8	159,2	136,5	95,6
VSI184/08/2B	130	175	307,2	296	284,3	282,8	276	262,7	244,5	222,3	198,1	174,9	161,9	136,1	89
VSI184/08/1B	150	200	318,9	307,2	294,7	293	286,7	273,3	255,5	234,4	209,9	186,8	173,5	147,7	100,8
VSI184/08	150	200	329,6	317,1	303,9	301,9	295,6	281,6	264	243,4	218,7	195,6	182,3	156,5	109,9
VSI184/09/2B	150	200	347,8	335,3	322	320,3	313	298,2	277,6	253,1	225,8	199,8	185,1	156,1	103,3
VSI184/09/1B	185	250	361,2	348	333,9	332,1	325,3	310,5	290,3	267,2	239,6	213,6	198,7	169,6	117,1
VSI184/09	185	250	371,9	358	343,1	341	334,3	319	299	276,4	248,6	222,7	207,6	178,7	126,5
VSI184/10/2B	185	250	390,3	376,3	361,4	359,6	352	335,9	312,9	286,4	256,1	227,2	210,8	178,5	120,1
VSI184/10/1B	185	250	401,0	386,3	370,6	368,5	360,9	344,3	321,5	295,5	264,9	236,1	219,6	187,4	129,3
VSI184/10	185	250	411,6	396,2	379,7	377,4	369,8	352,6	330,1	304,6	273,8	244,9	228,3	196,2	138,4
VSI184/11/2B	220	300	436,8	421,4	404,9	403	395,4	378,5	353	325,5	292	260,3	242,1	206,4	142,4
VSI184/11/1B	220	300	447,7	431,6	414,3	412,2	404,6	387,2	361,9	335	301,3	269,7	251,4	215,8	152,2
VSI184/11	220	300	458,7	441,8	423,7	421,3	413,8	395,9	370,9	344,5	310,7	279	260,6	225,2	162
VSI184/12/2B	220	300	477,4	460,6	442,4	440,3	432	413,4	385,3	355,2	318,7	284,1	264,3	225,5	155,9
VSI184/12/1B	220	300	488,3	470,7	451,8	449,4	441,1	422	394,2	364,7	327,9	293,4	273,4	234,8	165,6
VSI184/12	220	300	499,2	480,8	461,2	458,5	450,3	430,6	403,1	374,1	337,1	302,7	282,6	244,1	175,2
VSI184/13/2B	250	340	517,7	499,4	479,6	477,3	468,2	447,9	417,4	384,7	345	307,7	286,2	244,3	169,1
VSI184/13/1B	250	340	528,5	509,5	488,9	486,3	477,3	456,5	426,2	394,1	354,2	316,9	295,2	253,5	178,7
VSI184/13	250	340	539,4	519,5	498,3	495,4	486,4	465,1	435	403,4	363,3	326	304,3	262,6	188,2
VSI184/14/2B	250	340	557,9	538,1	516,7	514,2	504,3	482,2	449,2	413,7	371	330,8	307,6	262,7	182
VSI184/14/1B	250	340	568,7	548,2	526	523,2	513,3	490,7	457,9	422,9	380	339,8	316,6	271,7	191,4
VSI184/14	250	340	579,5	558,2	535,3	532,2	522,3	499,2	466,7	432,1	389	348,8	325,5	280,7	200,8
VSI184/15/2B	300	400	602,4	581,2	558,2	555,5	545,5	522,5	487	450,2	404,4	361,4	336,5	288,1	201,7
VSI184/15/1B	300	400	613,3	591,4	567,6	564,7	554,7	531,2	495,9	459,7	413,7	370,7	345,7	297,5	211,4
VSI184/15	300	400	624,2	601,5	577	573,8	563,9	539,8	504,9	469,2	423	380,1	355	306,9	221,2
VSI184/16/2B	300	400	642,9	620,2	595,6	592,7	582	557,2	519,3	479,9	431	385,2	358,6	307,2	215,1
VSI184/16/1B	300	400	653,8	630,4	605	601,8	591,1	565,9	528,2	489,3	440,3	394,5	367,8	316,5	224,8
VSI184/16	300	400	664,7	640,5	614,3	610,9	600,2	574,5	537,1	498,7	449,5	403,8	377	325,8	234,4



HYDRAULIC PERFORMANCE 50 Hz

VSI 344

Pump model	Rated power		Q = Delivery														
			m ³ /h 0	160,0	190	200	250	290	310	350	390	410	420	450	470	490	530
			l/min 0	2,666,7	3166,7	3333,3	4166,7	4833,3	5166,7	5833,3	6500	6833,3	7000	7500	7833,3	8166,7	8833,3
	US gpm	703,5	835,4	879,3	1099,2	1275	1363	1538,8	1714,7	1802,6	1846,6	1978,5	2066,4	2154,4	2330,3		
[kW]	[HP]	H = Total meters head of water column [m]															
VSI344/01/1C	30	40	40,7	37,5	35,1	34,3	31,2	28,1	26,1	21,4	16,5	13,8	12,4	8,1	5	4,3	
VSI344/01/1B	37	50	48,8	43,7	41,8	41,3	39,3	35,7	33,5	28,9	23,9	21,3	19,9	15,3	12,2	8,4	
VSI344/01/1A	45	60	57,5	50,4	48	47,1	46,1	43	40,9	36	31	28,2	26,8	22,2	18,7	15	5,6
VSI344/01	55	75	65,8	57,3	55,3	54,5	50,9	50,8	49	44,4	39,2	36,3	34,8	30,5	27	23,3	14,4
VSI344/02/2B	75	100	97,0	90,5	87,8	86,7	82,3	76,2	71,6	62,6	52,5	47,1	44,4	35,9	29,5	22,9	6,3
VSI344/02/1B	93	125	113,2	103,1	100,3	98,9	92,9	89,9	85,6	76,6	66,2	60,7	57,9	49,7	42,9	36,4	20,9
VSI344/02	110	150	128,9	114,5	111,6	110,3	103,6	101,4	97,9	89,1	78,8	73,7	71,1	62,5	56,2	49,9	33,8
VSI344/03/2B	130	175	160,8	148,8	145,2	143,2	134,8	128,7	122	108,5	93	84,8	80,7	68,5	58,6	49,2	27,3
VSI344/03/1B	150	200	176,6	160,6	156,9	155	145,9	140,7	134,8	121,5	106,1	98,2	94,3	81,8	72,4	63,1	40,7
VSI344/03	185	250	193,2	173,2	169,4	167,6	157,9	153,6	148,5	135,6	120,2	112,7	109	96,2	87,1	78,1	55,4
VSI344/04/2B	185	250	223,9	206,3	201,7	199,3	187,8	179,6	171,2	153,6	133	122,4	117,2	100,7	88,1	75,9	47
VSI344/04/1B	220	300	242,8	221,4	217	214,8	202,7	195,7	188,4	171,2	150,7	140,4	135,3	118,6	106,3	94,1	65,7
VSI344/04	220	300	258,5	232,9	228,2	226,1	213,3	207	200,3	183,5	163	153,1	148,2	131,3	119,3	107,5	78,6
VSI344/05/2B	250	340	289,6	266,4	261,2	258,3	243,9	233,8	224	202,2	176,5	163,6	157,2	136,5	121	105,9	70,8
VSI344/05/1B	250	340	305,1	277,7	272,2	269,4	254,2	244,9	235,7	214,2	188,5	176	169,8	148,8	133,8	119	83,4
VSI344/05	300	400	322,8	291,5	285,9	283,3	267,6	259,1	250,9	230,1	204,4	192,2	186,1	165	150,2	135,6	100,2
VSI344/06/2B	300	400	354,0	325,1	319,1	315,8	298,3	286,1	274,8	249	218,2	202,9	195,3	170,4	152,1	134,2	92,5
VSI344/06/1B	300	400	369,6	336,5	330,2	327	308,8	297,3	286,6	261,2	230,4	215,5	208,1	182,9	165	147,5	105,3
VSI344/06	350	470	386,1	348,9	342,3	339,3	320,5	309,8	299,8	274,7	244	229,4	222,3	196,8	179,3	162,1	119,6
VSI344/07/2B	350	470	417,2	382,4	375,3	371,5	351	336,5	323,4	293,4	257,5	239,9	231,2	202	181	160,4	111,8
VSI344/07/1B	350	470	432,8	393,7	386,3	382,6	361,3	347,6	335,1	305,4	269,5	252,3	243,9	214,3	193,8	173,6	124,3

VSI 454

Pump model	Rated power		Q = Delivery														
			m ³ /h 0	250	320	330	340	350	470	490	510	520	530	550	570	580	600
			l/min 0	4166,7	5333,3	5500	5666,7	5833,3	7833,3	8166,7	8500	8666,7	8.833,3	9.166,7	9.500	9.666,7	10.000
	US gpm	1099,2	1406,9	1450,9	1494,9	1538,8	2066,4	2154,4	2242,3	2286,3	2.330,2	2.418,2	2.506,1	2.550,1	2.638		
[kW]	[HP]	H = Total meters head of water column [m]															
VSI454/01/1C	55	75	57,3	42,2	40,6	41	41,1	41,1	33,2	31,4	29,7	28,8	27,9	26	24,1	23,2	21,1
VSI454/01/1B	60	80	60,2	44,3	42,4	42,8	43,1	43,2	35,9	34,1	32,4	31,5	30,7	28,9	27	26	24,2
VSI454/01/1A	67	90	64,6	47,7	45,7	46,4	46,8	46,9	39,8	38,2	36,6	35,8	34,9	33	31	30	28
VSI454/01	75	100	69,2	50,8	48,4	48,8	49,2	49,3	44,3	42,7	41,1	40,2	39,4	37,6	35,9	35,1	33,3
VSI454/02/2C	110	150	109,3	85,8	81,8	81,4	80,7	79,9	64,4	61,2	58	56,4	54,7	51,3	47,7	45,7	41,5
VSI454/02/1A	150	200	129,7	101,7	96,6	96,3	96	95,6	83,7	80,5	77,4	75,8	74,1	70,7	67,2	65,4	61,6

Pump model	Rated power		Q = Delivery														
			m ³ /h 0	340	350	360	490	510	520	530	550	570	580	600	620	640	650
			l/min 0	5666,7	5833,3	6000	8166,7	8500	8666,7	8.833,3	9.166,7	9.500	9.666,7	10.000	10.333,3	10.666,7	10.833,3
	US gpm	1494,9	1538,8	1582,8	2154,4	2242,3	2286,3	2.330,2	2.418,2	2.506,1	2.550,1	2.638	2.725,9	2.813,9	2.857,8		
[kW]	[HP]	H = Total meters head of water column [m]															
VSI454/03/1C	220	300	188,9	142,2	141	141	118,3	113,6	111,2	108,8	103,8	98,7	96	90,4	84,2	78	74,8
VSI454/03	220	300	200,7	152,3	151,5	151,5	130,1	125,4	122,8	120,3	115,2	110,2	107,7	102,4	96,2	90	87
VSI454/04/1B	300	400	256,9	196,1	194,5	194,5	163,9	157,8	154,5	151,2	144,4	137,5	134	126,7	118,7	110,6	106,5
VSI454/04	300	400	265,7	203,4	202	202	173,1	166,7	163,4	160	153,2	146,5	143,2	136,1	127,9	119,8	116
VSI454/05/1B	350	470	320,9	245,9	243,7	243,7	205,4	197,6	193,5	189,3	180,8	172,3	168	158,9	148,8	138,9	134
VSI454/05	350	470	329,6	253	251,1	251,1	214,3	206,3	202,1	197,9	189,4	181,2	177,1	168,1	157,9	148	143,3

VSI 134 - 50 Hz

TECHNICAL DATA - PUMP END

Pump model	Motor bracket type	Cable guard type ⁽¹²⁾	Dimensions [mm]			Net weight [kg]
			L1	ØD1 ⁽³⁾		
				DOL	SD	Pump
VSI 134/01	M6	L	542	202	209	25,5
VSI 134/02	M6	L	687	202	209	33,5
VSI 134/03	M6	L	832	202	209	41,5
VSI 134/04	M6	L	977	202	209	50
VSI 134/05	M6	L	1122	202	209	58
VSI 134/06	M6	L	1267	202	209	66
VSI 134/06	M8	L	1267	202	209	66
VSI 134/07	M8	L	1412	202	209	74,5
VSI 134/08	M8	L	1557	202	209	82,5
VSI 134/09	M8	L	1702	202	209	90,5
VSI 134/10	M8	L	1847	202	209	99
VSI 134/11	M8	L	1992	202	209	107
VSI 134/12	M8	L	2137	202	209	115
VSI 134/13	M8	L	2282	202	209	123,5
VSI 134/13	M10 ⁽⁷⁾	M	2303	210	221	127
VSI 134/14	M8	L	2427	202	209	131,5
VSI 134/14	M10 ⁽⁷⁾	M	2448	210	221	135
VSI 134/15	M8	L	2572	202	209	139,5
VSI 134/15	M10 ⁽⁷⁾	M	2593	210	221	143
VSI 134/16	M8	L	2717	202	209	148
VSI 134/16	M10 ⁽⁷⁾	M	2738	210	221	151,5
VSI 134/17	M8	L	2862	202	209	156
VSI 134/17	M10 ⁽⁷⁾	M	2883	210	221	159,5
VSI 134/18	M8	L	3007	202	209	164
VSI 134/18	M10 ⁽⁷⁾	M	3028	210	221	167,5
VSI 134/19	M8	L	3152	202	209	172,5
VSI 134/19	M10 ⁽⁷⁾	M	3173	210	221	176
VSI 134/20	M8	L	3297	202	209	180,5
VSI 134/20	M10 ⁽⁷⁾	M	3318	210	221	184

⁽³⁾ ØD1: maximum pump diameter

⁽⁷⁾ Pump with kit motor adapter. Already included in length and weight values. For more information see page 42.

⁽¹²⁾ Low (L); Medium (M); High (H). For more information see page 44.

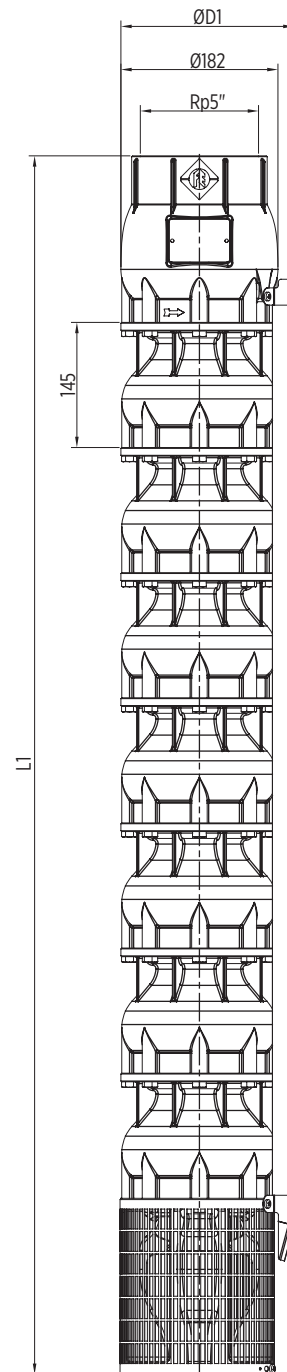

003E081 04/2013

VSI 134 - 50 Hz

TECHNICAL DATA - PUMPS WITH ENCAPSULATED MOTORS

Pump model	Motor			Dimensions [mm]				Net weight [kg]	
	Type	[kW]	[HP]	L	ØD ⁽⁴⁾		ØM	Total	
				Motor	DOL	SD		PMA	
VSI 134/01	CT6	9,3	12,5	1210	202	209	137	47	
VSI 134/02	CT6	15	20	1453	202	209	137	55	
VSI 134/03	CT6	22	30	1728	202	209	137	68	
VSI 134/04	CT6	30	40	2003	202	209	137	81	
VSI 134/05	CT6	37	50	2599	202	209	137	118	
VSI 134/06	CT6	45	60	2896	202	209	137	134	
VSI 134/07	CT8	55	75	2676	207	212	191	196	
VSI 134/08	CT8	75	100	3012	207	212	191	232	
VSI 134/09	CT8	75	100	3157	207	212	191	232	
VSI 134/10	CT8	75	100	3302	207	212	191	232	
VSI 134/11	CT8	93	125	3740	207	212	191	290	
VSI 134/12	CT8	93	125	3885	207	212	191	290	
VSI 134/13	CT8	110	150	4258	207	212	191	334	
VSI 134/14	CT8	110	150	4403	207	212	191	334	
VSI 134/15	CT8	130	175	4751	207	212	191	380	
VSI 134/16	CT8	130	175	4896	207	212	191	380	
VSI 134/17	CT8	130	175	5041	207	212	191	380	
VSI 134/18	CT8	150	200	5415	207	212	191	429	
VSI 134/19	CT8	150	200	5560	207	212	191	429	
VSI 134/20	CT8	150	200	5705	207	212	191	429	

⁽⁴⁾ ØD: maximum electropump diameter

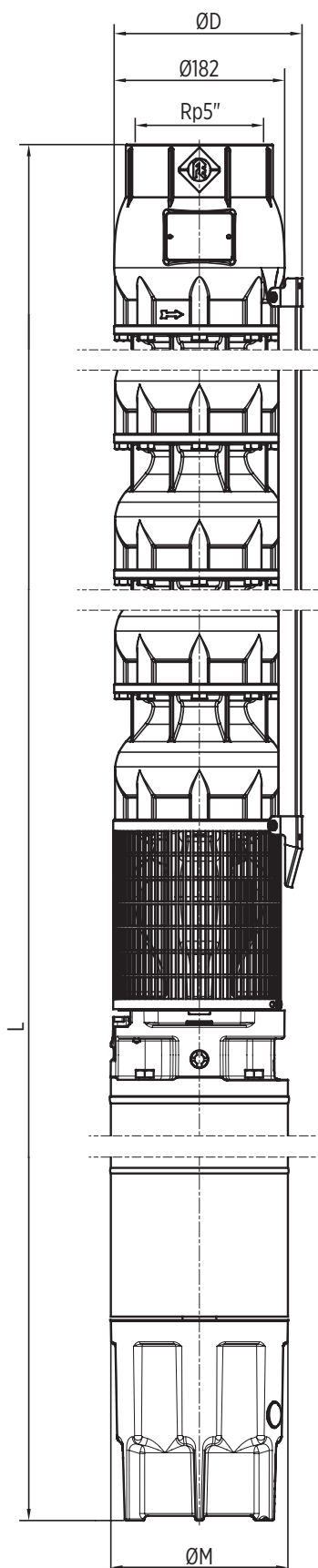

VSI 134 - 50 Hz

TECHNICAL DATA - PUMPS WITH REWINDABLE MOTORS

Pump model	Motor			Dimensions [mm]				Net weight [kg]	
	Type	[kW]	[HP]	L	ØD ⁽⁴⁾		ØM	Total	
				Motor	DOL	SD		PMA	
VSI 134/01	RW6	9,3	12,5	1271	202	209	142	49	
VSI 134/02	RW6	15	20	1541	202	209	142	61	
VSI 134/03	RW6	22	30	1821	202	209	142	77	
VSI 134/04	RW6	30	40	2171	202	209	142	98	
VSI 134/05	RW6 ⁽⁹⁾	37	50	2396	202	209	142	105	
VSI 134/06	RW8	45	60	2497	207	212	194	156	
VSI 134/07	RW8	52	70	2752	207	212	194	179	
VSI 134/08	RW8	60	80	3027	207	212	194	198	
VSI 134/09	RW8	67	90	3172	207	212	194	198	
VSI 134/10	RW8	75	100	3407	207	212	194	215	
VSI 134/11	RW8	83	110	3732	207	212	194	247	
VSI 134/12	RW8 ⁽⁹⁾	93	125	3877	207	212	194	247	
VSI 134/13	RW10	110	150	3832	235	235	235	315	
VSI 134/14	RW10	110	150	3977	235	235	235	315	
VSI 134/15	RW10	130	175	4252	235	235	235	362	
VSI 134/16	RW10	130	175	4397	235	235	235	362	
VSI 134/17	RW10	130	175	4542	235	235	235	362	
VSI 134/18	RW10	150	200	4797	235	235	235	413	
VSI 134/19	RW10	150	200	4942	235	235	235	413	
VSI 134/20	RW10	150	200	5087	235	235	235	413	

⁽⁹⁾ Not suitable for horizontal installation. Already included in length and weight values.

⁽⁴⁾ ØD: maximum electropump diameter

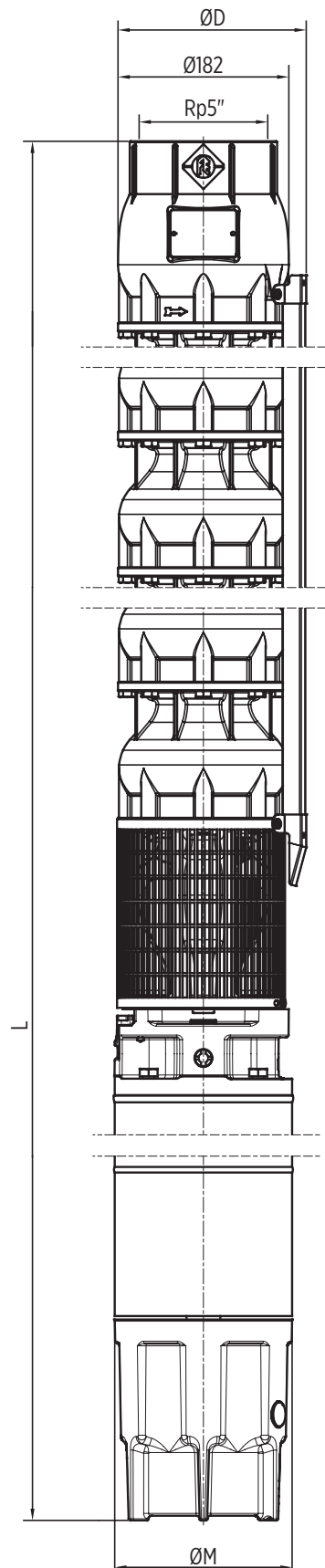

VSI 134 - PERFORMANCE CURVES AT 50 Hz

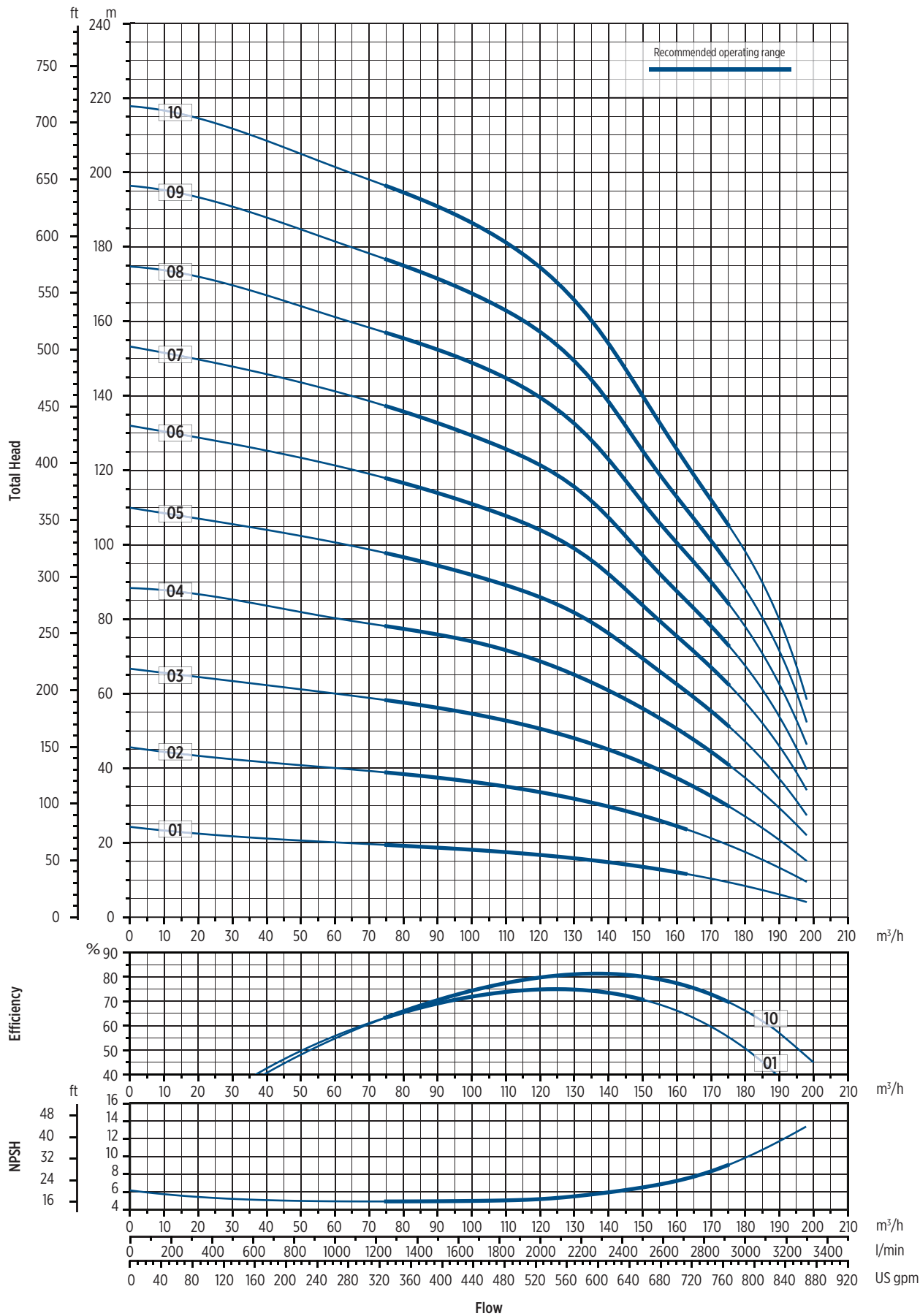

00120295 06/2023

The hydraulic characteristics are guaranteed, according to ISO standard 9906:2012, grade 3B



VSI 134 - PERFORMANCE CURVES AT 50 Hz

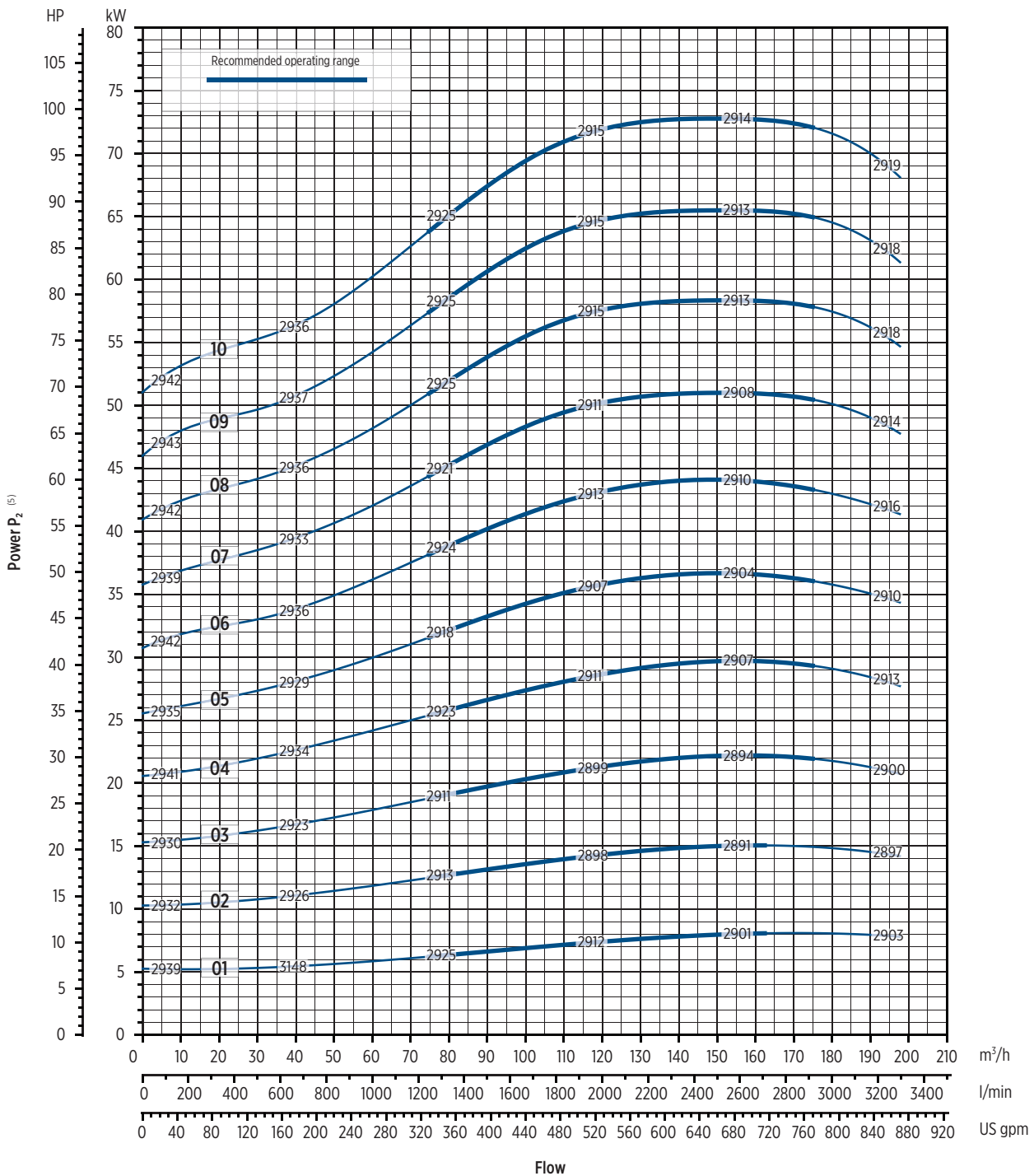

⁽⁶⁾ Motor speed referred to rewindable motor

Performance curves (Q-H-P) will change according to the formulas above.
Performance curves of Q, H and P depend on the rpm number according to the following formula:

$$Q_2 = Q_1 \cdot \left(\frac{n_2}{n_1}\right), \quad H_2 = H_1 \cdot \left(\frac{n_2}{n_1}\right)^2, \quad P_2 = P_1 \cdot \left(\frac{n_2}{n_1}\right)^3, \quad \eta \text{ remains approximately the same.}$$

The rpm number related to the performance curves (Q-H-P) is indicated in the power chart.
Performance curves (Q-H-P) will change according to the formulas above.
Q=Flow, H=Head, P=Power, η=Efficiency

The hydraulic characteristics are guaranteed, according to ISO standard 9906:2012, grade 3B

VSI 134 - PERFORMANCE CURVES AT 50 Hz

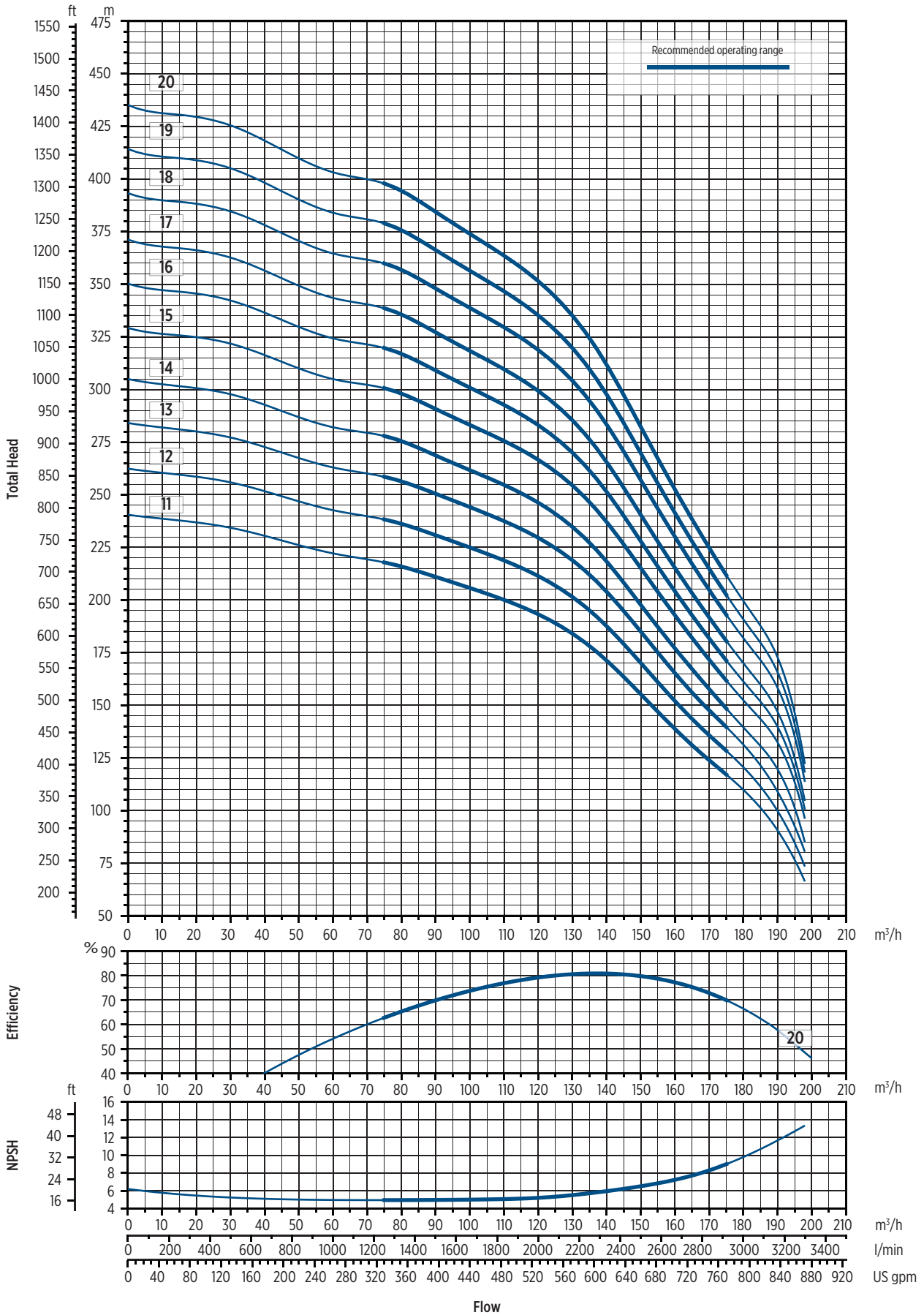

00720296 06/2023

The hydraulic characteristics are guaranteed, according to ISO standard 9906:2012, grade 3B



VSI 134 - PERFORMANCE CURVES AT 50 Hz

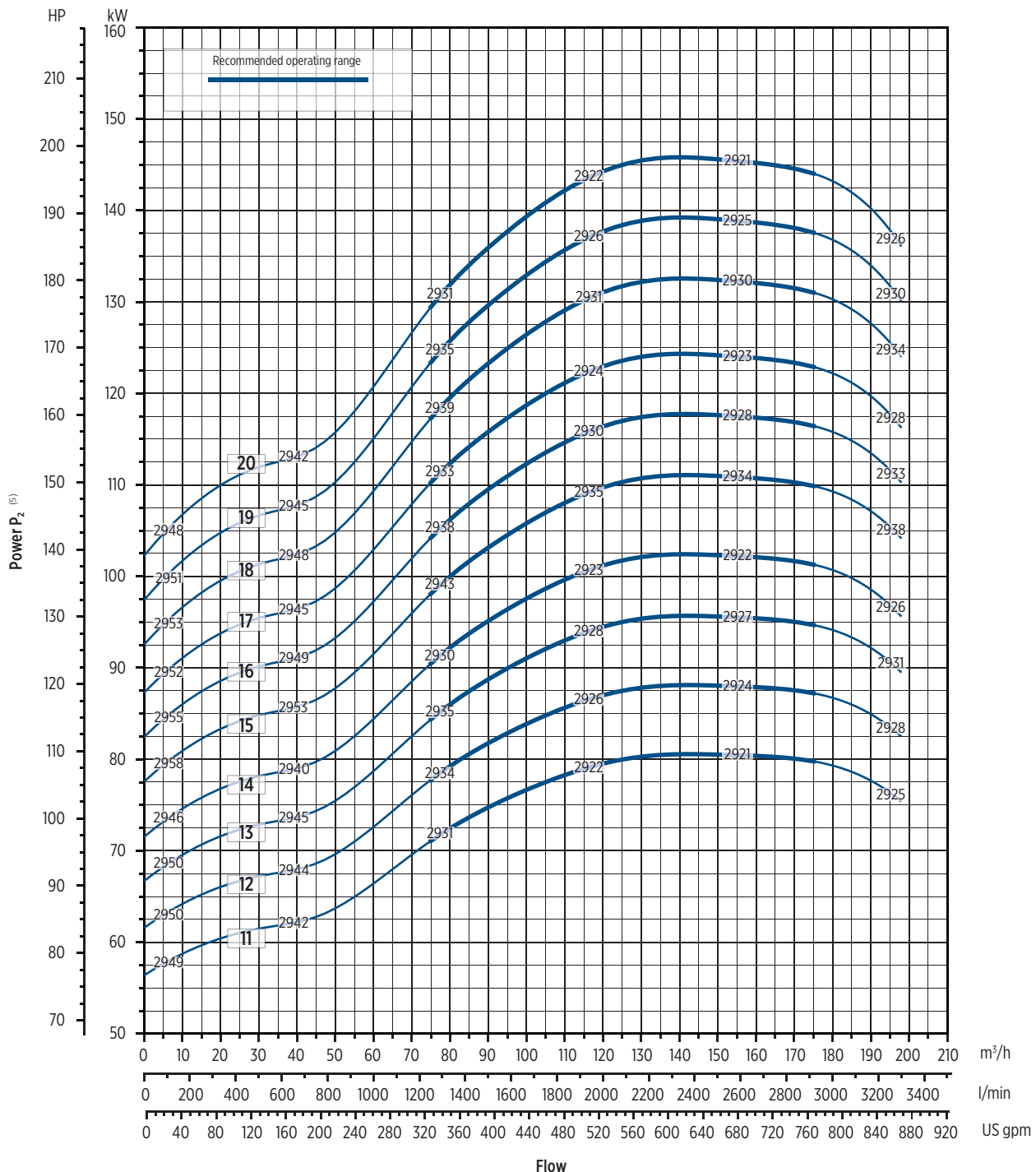

⁽⁶⁾ Motor speed referred to rewindable motor

Performance curves (Q-H-P) will change according to the formulas above.
Performance curves of Q, H and P depend on the rpm number according to the following formula:

$$Q_2 = Q_1 \cdot \left(\frac{n_2}{n_1}\right), \quad H_2 = H_1 \cdot \left(\frac{n_2}{n_1}\right)^2, \quad P_2 = P_1 \cdot \left(\frac{n_2}{n_1}\right)^3, \quad \eta \text{ remains approximately the same.}$$

The rpm number related to the performance curves (Q-H-P) is indicated in the power chart.
Performance curves (Q-H-P) will change according to the formulas above.
Q=Flow, H=Head, P=Power, η=Efficiency



VSI 184 - 50 Hz

TECHNICAL DATA - PUMP END

Pump model	Motor bracket type	Cable guard type ⁽¹²⁾	Dimensions [mm]			Net weight [kg]
			L1 ⁽⁶⁾	ØD1 ⁽³⁾		
				DOL	SD	Pump
VSI 184/01/1B	M6 ⁽⁸⁾	L	738	256	262	56,5
VSI 184/01	M6 ⁽⁸⁾	L	738	256	262	57
VSI 184/02/2B	M6 ⁽⁸⁾	L	908	256	262	73
VSI 184/02/1B	M6 ⁽⁸⁾	L	908	256	262	73,5
VSI 184/02	M6 ⁽⁸⁾	L	908	256	262	74
VSI 184/03/2B	M6 ⁽⁸⁾	L	1078	256	262	90
VSI 184/03/2B	M8	L	1041	256	262	85
VSI 184/03/1B	M8	L	1041	256	262	85,5
VSI 184/03	M8	L	1041	256	262	86
VSI 184/04/2B	M8	L	1211	256	262	101,5
VSI 184/04/1B	M8	L	1211	256	262	102
VSI 184/04	M8	L	1211	256	262	102,5
VSI 184/05/2B	M8	L	1381	256	262	118,5
VSI 184/05/1B	M8	L	1381	256	262	119
VSI 184/05	M8	L	1381	256	262	119,5
VSI 184/06/2B	M8	L	1551	256	262	135
	M10	M	1551	264	274	135
VSI 184/06/1B	M8	L	1551	256	262	135,5
	M10	M	1551	264	274	135,5
VSI 184/06	M8	L	1551	256	262	136
	M10	M	1551	264	274	136
VSI 184/07/2B	M8	L	1721	256	262	152
	M10	M	1721	264	274	152
VSI 184/07/1B	M8	L	1721	256	262	152,5
	M10	M	1721	264	274	152,5
VSI 184/07	M8	L	1721	256	262	153
	M10	M	1721	264	274	153
VSI 184/08/2B	M8	L	1891	256	262	168,5
	M10	M	1891	264	274	168,5
VSI 184/08/1B	M8	L	1891	256	262	169
	M10	M	1891	264	274	169
VSI 184/08	M8	L	1891	256	262	169,5
	M10	M	1891	264	274	169,5
VSI 184/09/2B	M8	L	2061	256	262	185,5
	M10	M	2061	264	274	185,5
VSI 184/09/1B	M10	M	2061	264	274	186
VSI 184/09	M10	M	2061	264	274	186,5
VSI 184/10/2B	M10	M	2231	264	274	202
VSI 184/10/1B	M10	M	2231	264	274	202,5
VSI 184/10	M10	M	2231	264	274	203
VSI 184/11/2B	M12	M	2401	264	274	219
VSI 184/11/1B	M12	M	2401	264	274	219,5
VSI 184/11	M12	M	2401	264	274	220
VSI 184/12/2B	M12	M	2571	264	274	236
VSI 184/12/1B	M12	M	2571	264	274	236,5
VSI 184/12	M12	M	2571	264	274	237
VSI 184/13/2B	M12	M	2741	264	274	252,5
VSI 184/13/1B	M12	M	2741	264	274	253
VSI 184/13	M12	M	2741	264	274	253,5
VSI 184/14/2B	M12	M	2911	264	274	269,5
VSI 184/14/1B	M12	M	2911	264	274	270
VSI 184/14	M12	M	2911	264	274	270,5
VSI 184/15/2B	M12	M	3081	264	274	286
VSI 184/15/1B	M12	M	3081	264	274	286,5
VSI 184/15	M12	M	3081	264	274	287
VSI 184/16/2B	M12	M	3251	264	274	303
VSI 184/16/1B	M12	M	3251	264	274	303,5
VSI 184/16	M12	M	3251	264	274	304

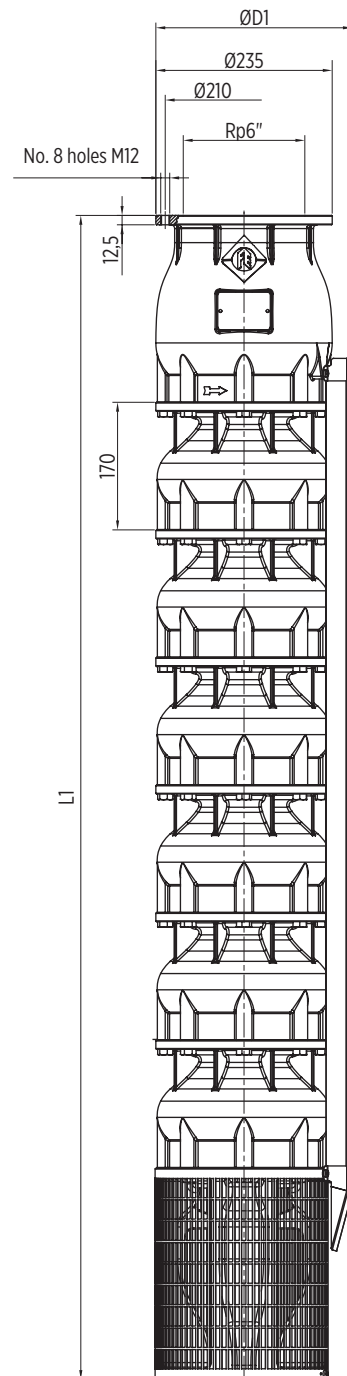

00130209 04/2023

⁽³⁾ ØD1: maximum pump diameter

⁽⁶⁾ Lengths without counterflange

⁽⁸⁾ Necessary kit P10xM6 (not included, Ref. n. 20.06, Code 14251020). Already included in length and weight values. For more information see page 43.

⁽¹²⁾ Low (L); Medium (M); High (H). For more information see page 44.

VSI 184 - 50 Hz

TECHNICAL DATA - PUMPS WITH ENCAPSULATED MOTORS

Pump model	Motor			Dimensions [mm]				Net weight [kg]	
	Type	[kW]	[HP]	ØD ⁽⁴⁾			ØM	Total	
				Motor	DOL	SD		PMA	
VSI 184/01/1B	CT6 ⁽⁸⁾	15	20	1504	256	262	137	55	
VSI 184/01	CT6 ⁽⁸⁾	18,5	25	1569	256	262	137	62	
VSI 184/02/2B	CT6 ⁽⁸⁾	30	40	1934	256	262	137	81	
VSI 184/02/1B	CT6 ⁽⁸⁾	30	40	1934	256	262	137	81	
VSI 184/02	CT6 ⁽⁸⁾	37	50	2385	256	262	137	118	
VSI 184/03/2B	CT6 ⁽⁸⁾	45	60	2707	256	262	137	134	
VSI 184/03/1B	CT8	55	75	2305	256	262	191	196	
VSI 184/03	CT8	55	75	2305	256	262	191	196	
VSI 184/04/2B	CT8	75	100	2666	256	262	191	232	
VSI 184/04/1B	CT8	75	100	2666	256	262	191	232	
VSI 184/04	CT8	75	100	2666	256	262	191	232	
VSI 184/05/2B	CT8	93	125	3129	256	262	191	290	
VSI 184/05/1B	CT8	93	125	3129	256	262	191	290	
VSI 184/05	CT8	93	125	3129	256	262	191	290	
VSI 184/06/2B	CT8	110	150	3527	256	262	191	334	
VSI 184/06/1B	CT8	110	150	3527	256	262	191	334	
VSI 184/06	CT8	110	150	3527	256	262	191	334	
VSI 184/07/2B	CT8	130	175	3900	256	262	191	380	
VSI 184/07/1B	CT8	130	175	3900	256	262	191	380	
VSI 184/07	CT8	130	175	3900	256	262	191	380	
VSI 184/08/2B	CT8	130	175	4070	256	262	191	380	
VSI 184/08/1B	CT8	150	200	4299	256	262	191	429	
VSI 184/08	CT8	150	200	4299	256	262	191	429	
VSI 184/09/2B	CT8	150	200	4469	256	262	191	429	

⁽⁴⁾ ØD: maximum electropump diameter

⁽⁸⁾ Necessary kit P10xM6 (not included, Ref. n. 20.06, Code 14251020). Already included in length and weight values. For more information see page 43.

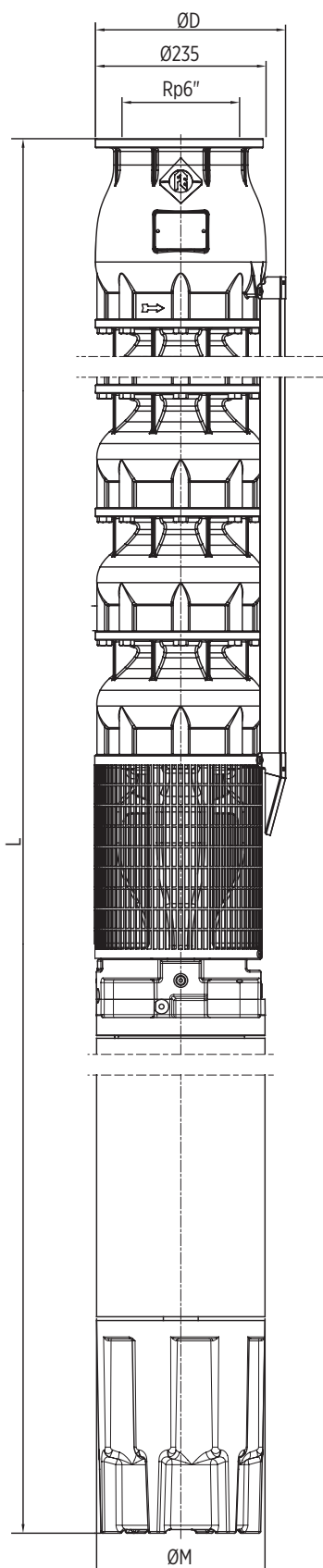

VSI 184 - 50 Hz

TECHNICAL DATA - PUMPS WITH REWINDABLE MOTORS

Pump model	Motor			Dimensions [mm]				Net weight [kg]	
	Type	[kW]	[HP]	L		ØD ⁽⁴⁾		ØM	Total
				Motor	DOL	SD	PMA		
VSI 184/01/1B	RW6 ⁽⁸⁾	13	17,5	1547	256	262	142	57	
VSI 184/01	RW6 ⁽⁸⁾	18,5	25	1637	256	262	142	66	
VSI 184/02/2B	RW6 ⁽⁸⁾	26	35	2002	256	262	142	88	
VSI 184/02/1B	RW6 ⁽⁸⁾	30	40	2102	256	262	142	98	
VSI 184/02	RW6 ^{(8) (9)}	37	50	2182	256	262	142	105	
VSI 184/03/2B	RW8	45	60	2271	256	262	194	156	
VSI 184/03/1B	RW8	52	70	2381	256	262	194	179	
VSI 184/03	RW8	55	75	2381	256	262	194	179	
VSI 184/04/2B	RW8	60	80	2681	256	262	194	198	
VSI 184/04/1B	RW8	67	90	2681	256	262	194	198	
VSI 184/04	RW8	75	100	2771	256	262	194	215	
VSI 184/05/2B	RW8	83	110	3121	256	262	194	247	
VSI 184/05/1B	RW8 ⁽⁹⁾	93	125	3121	256	262	194	247	
VSI 184/05	RW8 ⁽⁹⁾	93	125	3121	256	262	194	247	
VSI 184/06/2B	RW10	110	150	3080	264	274	235	315	
VSI 184/06/1B	RW10	110	150	3080	264	274	235	315	
VSI 184/06	RW10	110	150	3080	264	274	235	315	
VSI 184/07/2B	RW10	130	175	3380	264	274	235	362	
VSI 184/07/1B	RW10	130	175	3380	264	274	235	362	
VSI 184/07	RW10	130	175	3380	264	274	235	362	
VSI 184/08/2B	RW10	130	175	3550	264	274	235	362	
VSI 184/08/1B	RW10	150	200	3660	264	274	235	413	
VSI 184/08	RW10	150	200	3660	264	274	235	413	
VSI 184/09/2B	RW10	150	200	3830	264	274	235	413	
VSI 184/09/1B	RW10 ⁽⁹⁾	185	250	3980	264	274	235	449	
VSI 184/09	RW10 ⁽⁹⁾	185	250	3980	264	274	235	449	
VSI 184/10/2B	RW10 ⁽⁹⁾	185	250	4150	264	274	235	449	
VSI 184/10/1B	RW10 ⁽⁹⁾	185	250	4150	264	274	235	449	
VSI 184/10	RW10 ⁽⁹⁾	185	250	4150	264	274	235	449	
VSI 184/11/2B	RW12	220	300	4294	288	288	286	663	
VSI 184/11/1B	RW12	220	300	4294	288	288	286	663	
VSI 184/11	RW12	220	300	4294	288	288	286	663	
VSI 184/12/2B	RW12	220	300	4464	288	288	286	663	
VSI 184/12/1B	RW12	220	300	4464	288	288	286	663	
VSI 184/12	RW12	220	300	4464	288	288	286	663	
VSI 184/13/2B	RW12	250	340	4634	288	288	286	663	
VSI 184/13/1B	RW12	250	340	4634	288	288	286	663	
VSI 184/13	RW12	250	340	4634	288	288	286	663	
VSI 184/14/2B	RW12	250	340	4804	288	288	286	663	
VSI 184/14/1B	RW12	250	340	4804	288	288	286	663	
VSI 184/14	RW12	250	340	4804	288	288	286	663	
VSI 184/15/2B	RW12	300	400	5124	288	288	286	726	
VSI 184/15/1B	RW12	300	400	5124	288	288	286	726	
VSI 184/15	RW12	300	400	5124	288	288	286	726	
VSI 184/16/2B	RW12	300	400	5294	288	288	286	726	
VSI 184/16/1B	RW12	300	400	5294	288	288	286	726	
VSI 184/16	RW12	300	400	5294	288	288	286	726	

⁽⁴⁾ ØD: maximum electropump diameter

⁽⁸⁾ Necessary kit P10xM6 (not included, Ref. n. 20.06, Code 14251020). Already included in length and weight values. For more information see page 43.

⁽⁹⁾ Not suitable for horizontal installation. Already included in length and weight values.

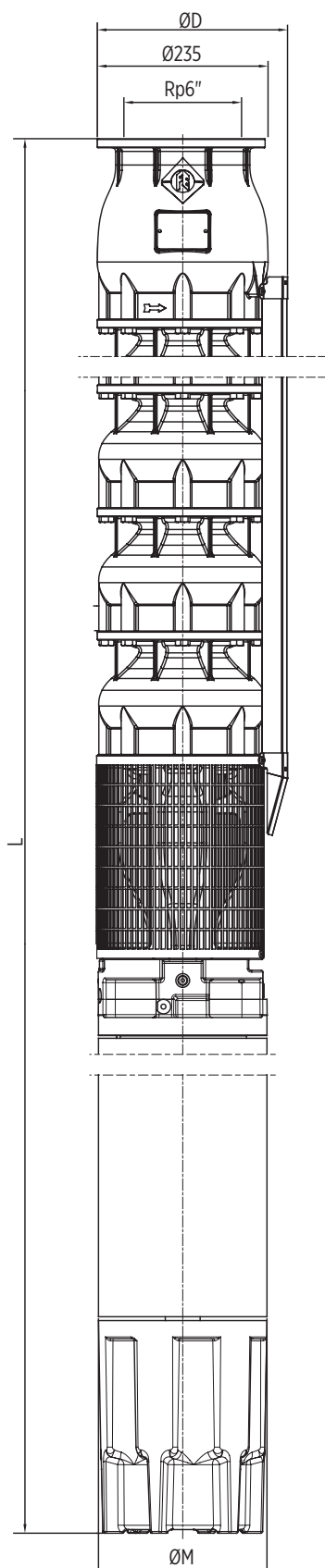

VSI 184 - PERFORMANCE CURVES AT 50 Hz

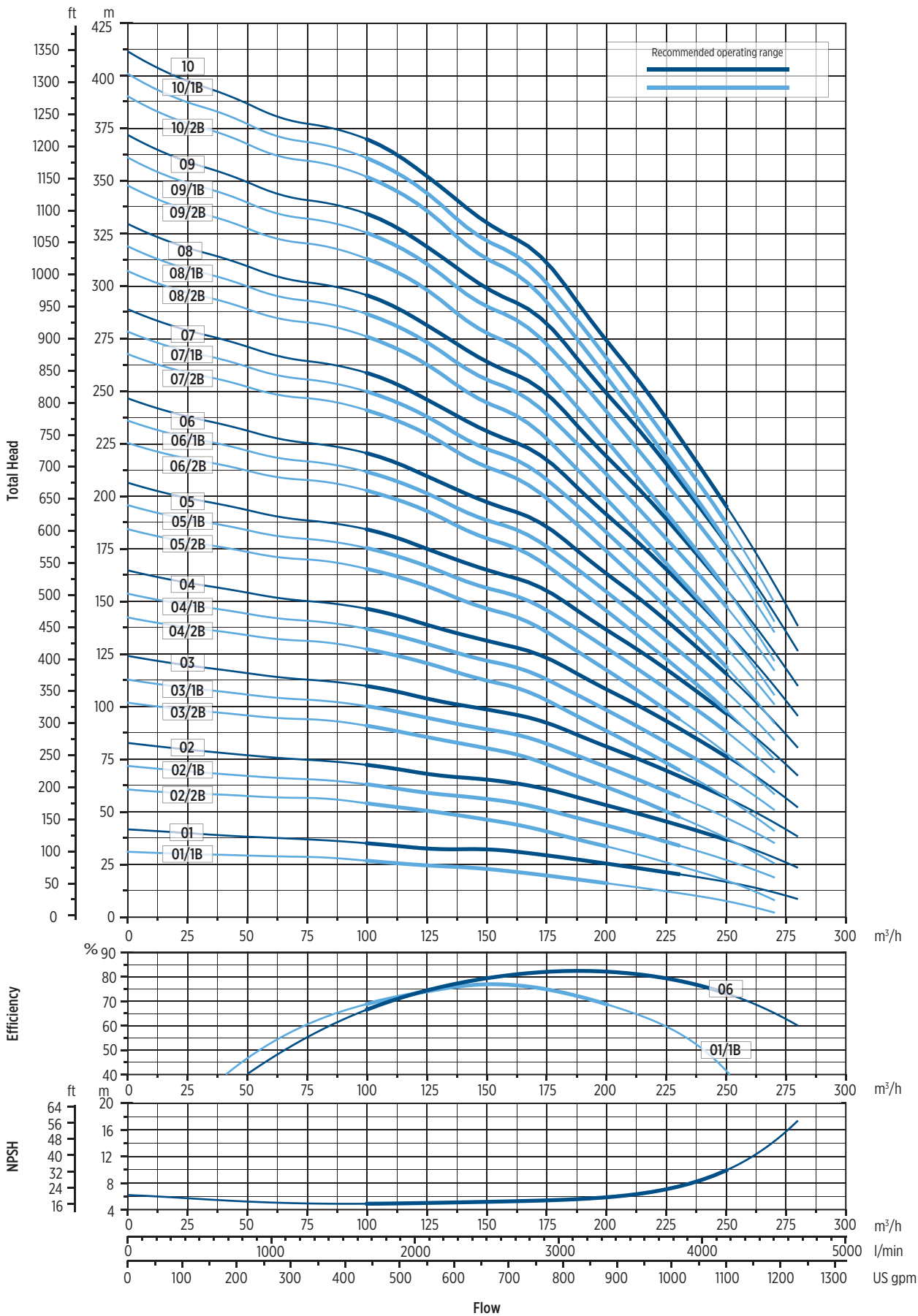

The hydraulic characteristics are guaranteed, according to ISO standard 9906:2012, grade 3B

00120291/04/2023

VSI 184 - PERFORMANCE CURVES AT 50 Hz

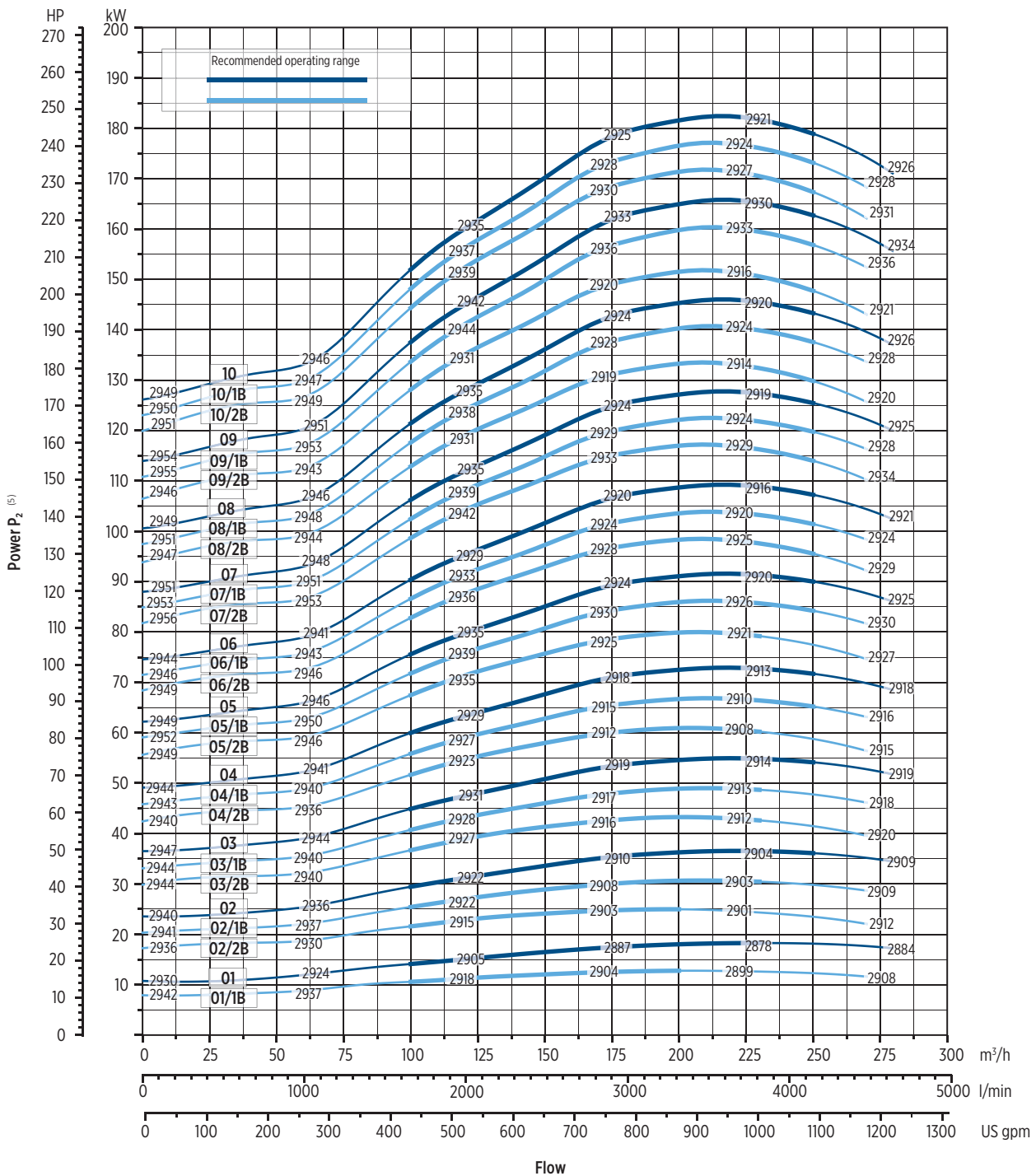

001020291 04/2023

⁽⁵⁾ Motor speed referred to rewindable motor

Performance curves (Q-H-P) will change according to the formulas above.
 Performance curves of Q, H and P depend on the rpm number according to the following formula:

$$Q_2 = Q_1 \cdot \left(\frac{n_2}{n_1}\right), \quad H_2 = H_1 \cdot \left(\frac{n_2}{n_1}\right)^2, \quad P_2 = P_1 \cdot \left(\frac{n_2}{n_1}\right)^3, \quad \eta \text{ remains approximately the same.}$$

The rpm number related to the performance curves (Q-H-P) is indicated in the power chart.
 Performance curves (Q-H-P) will change according to the formulas above.
 Q=Flow, H=Head, P=Power, η =Efficiency

The hydraulic characteristics are guaranteed, according to ISO standard 9906:2012, grade 3B

VSI 184 - PERFORMANCE CURVES AT 50 Hz

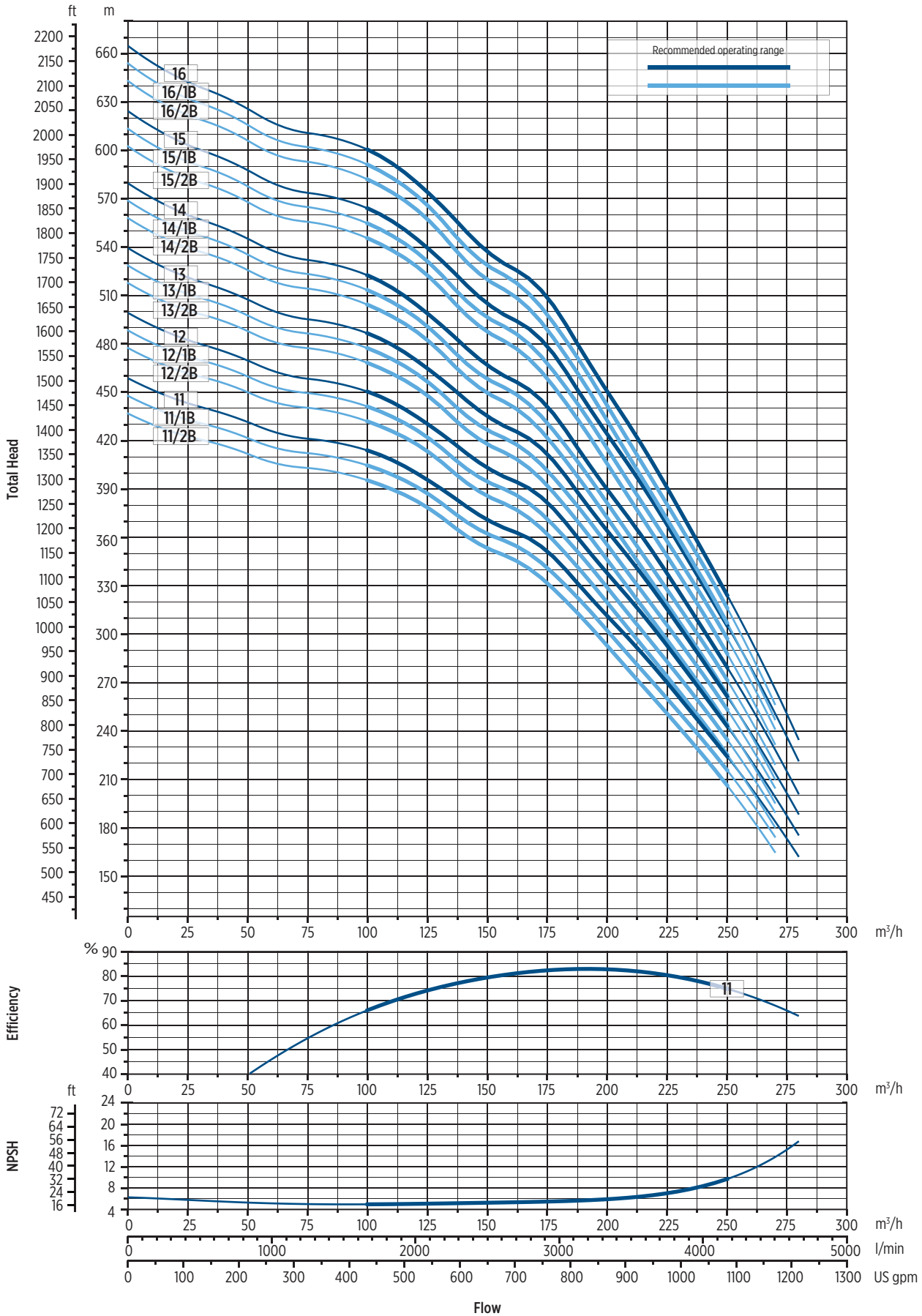

00720292_04/2023

The hydraulic characteristics are guaranteed, according to ISO standard 9906:2012, grade 3B



VSI 184 - PERFORMANCE CURVES AT 50 Hz

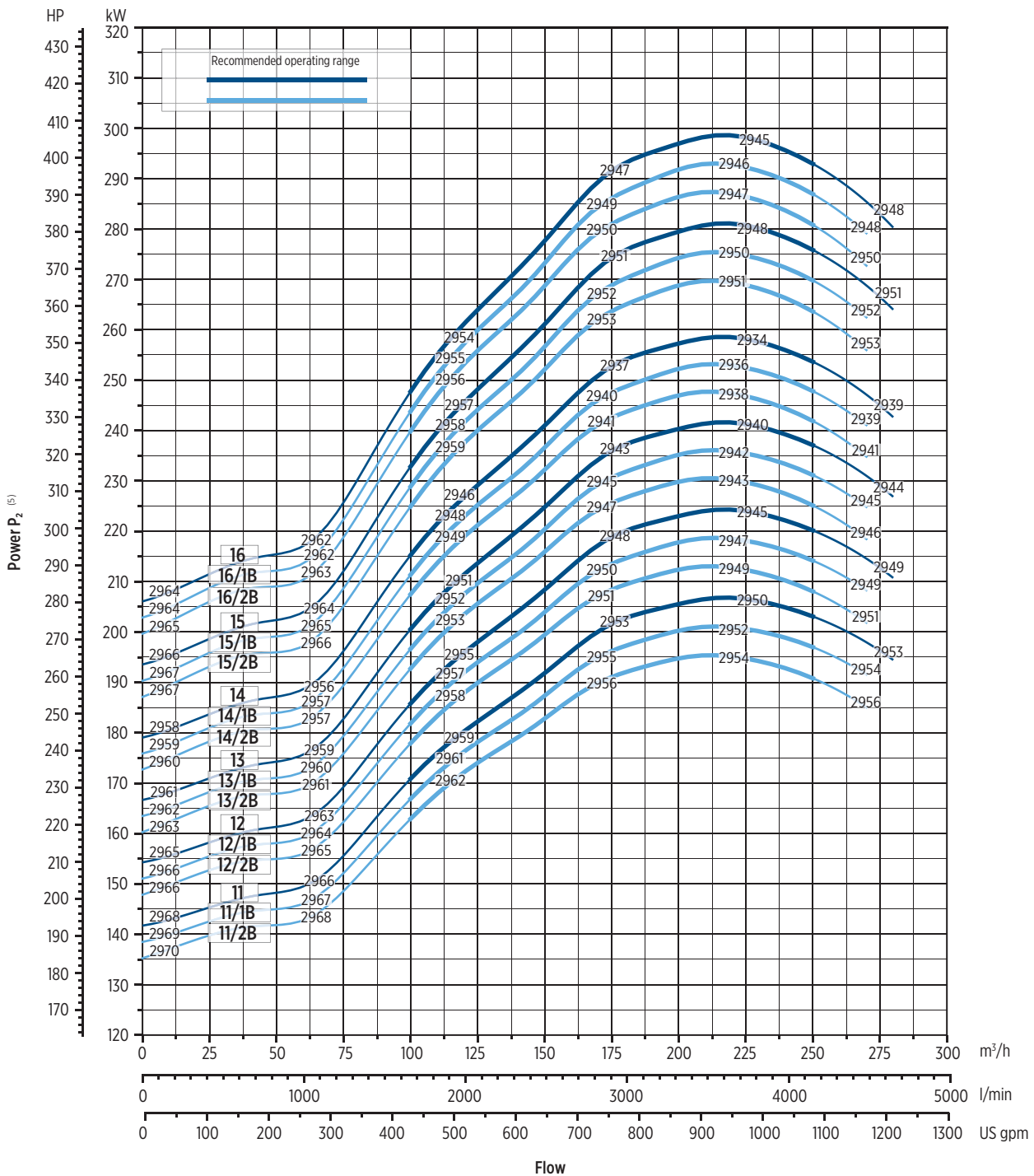

00102392_04/2023

⁽⁶⁾ Motor speed referred to rewindable motor

Performance curves (Q-H-P) will change according to the formulas above.
 Performance curves of Q, H and P depend on the rpm number according to the following formula:

$$Q_2 = Q_1 \cdot \left(\frac{n_2}{n_1}\right), \quad H_2 = H_1 \cdot \left(\frac{n_2}{n_1}\right)^2, \quad P_2 = P_1 \cdot \left(\frac{n_2}{n_1}\right)^3, \quad \eta \text{ remains approximately the same.}$$

The rpm number related to the performance curves (Q-H-P) is indicated in the power chart.
 Performance curves (Q-H-P) will change according to the formulas above.
 Q=Flow, H=Head, P=Power, η =Efficiency

The hydraulic characteristics are guaranteed, according to ISO standard 9906:2012, grade 3B

VSI 254 - 50 Hz

TECHNICAL DATA - PUMP END

Pump model	Motor bracket type	Cable guard type ⁽¹²⁾	Dimensions [mm]			Net weight [kg]
			L1 ⁽⁶⁾	ØD1 ⁽³⁾		
				DOL	SD	Pump
VSI 254/01/1C	M6 ⁽⁸⁾	L	753	256	262	56
VSI 254/01/1B	M6 ⁽⁸⁾	L	753	256	262	57
VSI 254/01/1A	M6 ⁽⁸⁾	L	753	256	262	57,5
VSI 254/01	M6 ⁽⁸⁾	L	753	256	262	57,5
VSI 254/02/2B	M6 ⁽⁸⁾	L	938	256	262	73
VSI 254/02/1B	M6 ⁽⁸⁾	L	938	256	262	74
VSI 254/02/1B	M8	L	901	256	262	69
VSI 254/02	M8	L	901	256	262	69,5
VSI 254/03/3B	M8	L	1086	256	262	84,5
VSI 254/03/2B	M8	L	1086	256	262	85
VSI 254/03/1B	M8	L	1086	256	262	86
VSI 254/03	M8	L	1086	256	262	86,5
VSI 254/04/3B	M8	L	1271	256	262	102
VSI 254/04/2B	M8	L	1271	256	262	102,5
VSI 254/04/1B	M8	L	1271	256	262	103,5
VSI 254/04/1B	M10	M	1271	264	274	103,5
VSI 254/04	M8	L	1271	256	262	104
	M10	M	1271	264	274	104
VSI 254/05/3B	M8	L	1456	256	262	119
	M10	M	1456	264	274	119
VSI 254/05/2B	M8	L	1456	256	262	119,5
	M10	M	1456	264	274	119,5
VSI 254/05/1B	M8	L	1456	256	262	120,5
	M10	M	1456	264	274	120,5
VSI 254/05	M8	L	1456	256	262	121
	M10	M	1456	264	274	121
VSI 254/06/3B	M8	L	1641	256	262	136
	M10	M	1641	264	274	136
VSI 254/06/2B	M8	L	1641	256	262	136,5
	M10	M	1641	264	274	136,5
VSI 254/06/1B	M8	L	1641	256	262	137,5
	M10	M	1641	264	274	137,5
VSI 254/06	M8	L	1641	256	262	138
	M10	M	1641	264	274	138
VSI 254/07/3B	M10	M	1826	264	274	153
VSI 254/07/2B	M10	M	1826	264	274	153,5
VSI 254/07/1B	M10	M	1826	264	274	154,5
VSI 254/07	M10	M	1826	264	274	155
VSI 254/08/3B	M10	M	2011	264	274	170
VSI 254/08/2B	M12	M	2011	264	274	170,5
VSI 254/08/1B	M12	M	2011	264	274	171,5
VSI 254/08	M12	M	2011	264	274	172
VSI 254/09/3B	M12	M	2196	264	274	187,5
VSI 254/09/2B	M12	M	2196	264	274	188
VSI 254/09/1B	M12	M	2196	264	274	189
VSI 254/09	M12	M	2196	264	274	189,5

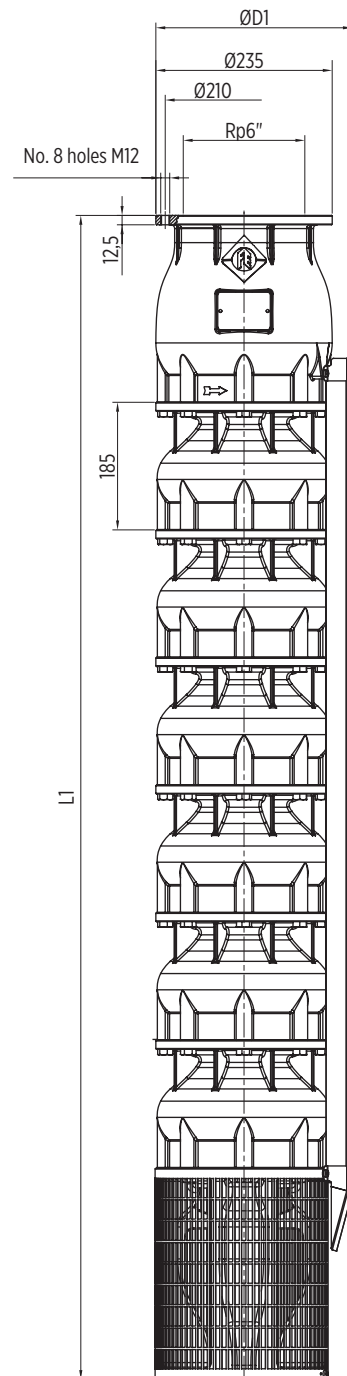

00130309 04/2023

⁽³⁾ ØD1: maximum pump diameter

⁽⁶⁾ Lengths without counterflange

⁽⁸⁾ Necessary kit P10xM6 (not included, Ref. n. 20.06, Code 14251020). Already included in length and weight values. For more information see page 43.

⁽¹²⁾ Low (L); Medium (M); High (H). For more information see page 44.

VSI 254 - 50 Hz

TECHNICAL DATA - PUMP END

Pump model	Motor bracket type	Cable guard type ⁽¹²⁾	Dimensions [mm]			Net weight [kg]
			L1 ⁽⁶⁾	ØD1 ⁽³⁾		
				DOL	SD	Pump
VSI 254/10/3B	M12	M	2381	264	274	204,5
VSI 254/10/2B	M12	M	2381	264	274	205
VSI 254/10/1B	M12	M	2381	264	274	206
VSI 254/10	M12	M	2381	264	274	206,5
VSI 254/11/3B	M12	M	2566	264	274	221,5
VSI 254/11/2B	M12	M	2566	264	274	222
VSI 254/11/1B	M12	M	2566	264	274	223
VSI 254/11	M12	M	2566	264	274	223,5
VSI 254/12/3B	M12	M	2751	264	274	238,5
VSI 254/12/2B	M12	M	2751	264	274	239
VSI 254/12/1B	M12	M	2751	264	274	240
VSI 254/12	M12	M	2751	264	274	240,5
VSI 254/13/3B	M12	M	2936	264	274	255,5
VSI 254/13/2B	M12	M	2936	264	274	256
VSI 254/13/1B	M12	M	2936	264	274	257
VSI 254/13	M12	M	2936	264	274	257,5
VSI 254/14/3B	M12	M	3121	264	274	273
VSI 254/14/2B	M12	M	3121	264	274	273,5

⁽³⁾ ØD1: maximum pump diameter

⁽⁶⁾ Lengths without counterflange

⁽⁸⁾ Necessary kit P10xM6 (not included, Ref. n. 20.06, Code 14251020). Already included in length and weight values. For more information see page 43.

⁽¹²⁾ Low (L); Medium (M); High (H). For more information see page 44.

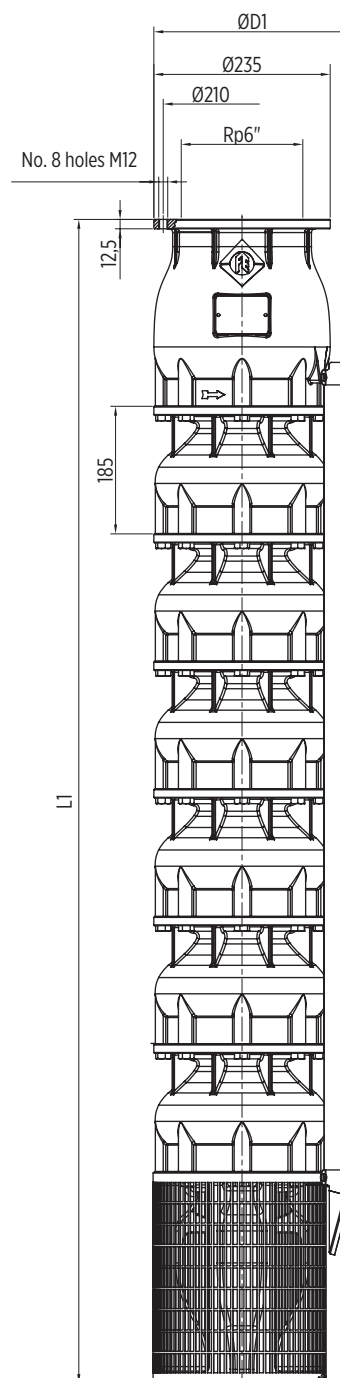

001330309 04/2023

VSI 254 - 50 Hz

TECHNICAL DATA - PUMPS WITH ENCAPSULATED MOTORS

Pump model	Motor			Dimensions [mm]				Net weight [kg]	
	Type	[kW]	[HP]	L ⁽⁶⁾	ØD ⁽⁴⁾		ØM	Total	
				Motor	DOL	SD		PMA	
VSI 254/01/1C	CT6 ⁽⁸⁾	15	20	1519	256	262	137	55	
VSI 254/01/1B	CT6 ⁽⁸⁾	18,5	25	1584	256	262	137	62	
VSI 254/01/1A	CT6 ⁽⁸⁾	22	30	1649	256	262	137	68	
VSI 254/01	CT6 ⁽⁸⁾	30	40	1779	256	262	137	81	
VSI 254/02/2B	CT6 ⁽⁸⁾	37	50	2415	256	262	137	118	
VSI 254/02/1B	CT6 ⁽⁸⁾	45	60	2567	256	262	137	134	
VSI 254/02	CT8	55	75	2165	256	262	191	196	
VSI 254/03/3B	CT8	55	75	2350	256	262	191	196	
VSI 254/03/2B	CT8	75	100	2541	256	262	191	232	
VSI 254/03/1B	CT8	75	100	2541	256	262	191	232	
VSI 254/03	CT8	93	125	2834	256	262	191	290	
VSI 254/04/3B	CT8	93	125	3019	256	262	191	290	
VSI 254/04/2B	CT8	93	125	3019	256	262	191	290	
VSI 254/04/1B	CT8	110	150	3247	256	262	191	334	
VSI 254/04	CT8	110	150	3247	256	262	191	334	
VSI 254/05/3B	CT8	110	150	3432	256	262	191	334	
VSI 254/05/2B	CT8	110	150	3432	256	262	191	334	
VSI 254/05/1B	CT8	130	175	3635	256	262	191	380	
VSI 254/05	CT8	130	175	3635	256	262	191	380	
VSI 254/06/3B	CT8	150	200	4049	256	262	191	429	
VSI 254/06/2B	CT8	150	200	4049	256	262	191	429	
VSI 254/06/1B	CT8	150	200	4049	256	262	191	429	
VSI 254/06	CT8	150	200	4049	256	262	191	429	

⁽⁴⁾ ØD: maximum electropump diameter

⁽⁶⁾ Lengths without counterflange

⁽⁸⁾ Necessary kit P10xM6 (not included, Ref. n. 20.06, Code 14251020). Already included in length and weight values. For more information see page 43.

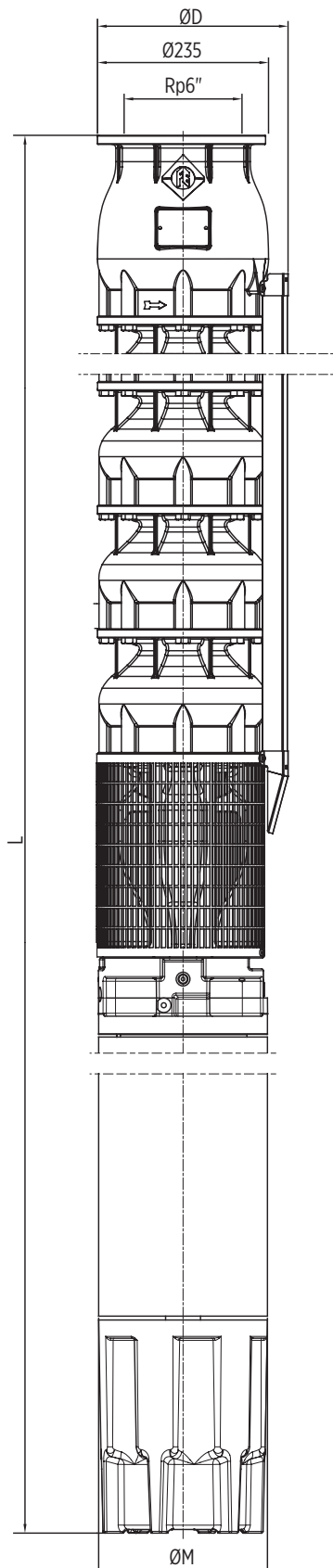

TECHNICAL DATA - PUMPS WITH REWINDABLE MOTORS

Pump model	Motor			Dimensions [mm]				Net weight [kg]	
	Type	[kW]	[HP]	L ⁽⁶⁾	ØD ⁽⁴⁾		ØM	Total	
				Motor	DOL	SD		PMA	
VSI 254/01/1C	RW6 ⁽⁸⁾	15	20	1607	256	262	142	61	
VSI 254/01/1B	RW6 ⁽⁸⁾	18,5	25	1652	256	262	142	66	
VSI 254/01/1A	RW6 ⁽⁸⁾	22	30	1742	256	262	142	77	
VSI 254/01	RW6 ⁽⁸⁾	30	40	1947	256	262	142	98	
VSI 254/02/2B	RW6 ^{(8) (9)}	37	50	2212	256	262	142	105	
VSI 254/02/1B	RW8	45	60	2131	256	262	194	156	
VSI 254/02	RW8	52	70	2241	256	262	194	179	
VSI 254/03/3B	RW8	55	75	2426	256	262	194	179	
VSI 254/03/2B	RW8	67	90	2556	256	262	194	198	
VSI 254/03/1B	RW8	75	100	2646	256	262	194	215	
VSI 254/03	RW8	83	110	2826	256	262	194	247	
VSI 254/04/3B	RW8	83	110	3011	256	262	194	247	
VSI 254/04/2B	RW8 ⁽⁹⁾	93	125	3011	256	262	194	247	
VSI 254/04/1B	RW10	110	150	2800	264	274	235	315	
VSI 254/04	RW10	110	150	2800	264	274	235	315	
VSI 254/05/3B	RW10	110	150	2985	264	274	235	315	
VSI 254/05/2B	RW10	110	150	2985	264	274	235	315	
VSI 254/05/1B	RW10	130	175	3115	264	274	235	362	
VSI 254/05	RW10	130	175	3115	264	274	235	362	
VSI 254/06/3B	RW10	150	200	3410	264	274	235	413	
VSI 254/06/2B	RW10	150	200	3410	264	274	235	413	
VSI 254/06/1B	RW10	150	200	3410	264	274	235	413	
VSI 254/06	RW10	150	200	3410	264	274	235	413	
VSI 254/07/3B	RW10 ⁽⁹⁾	185	250	3745	264	274	235	449	
VSI 254/07/2B	RW10 ⁽⁹⁾	185	250	3745	264	274	235	449	
VSI 254/07/1B	RW10 ⁽⁹⁾	185	250	3745	264	274	235	449	
VSI 254/07	RW10 ⁽⁹⁾	185	250	3745	264	274	235	449	
VSI 254/08/3B	RW10 ⁽⁹⁾	185	250	3930	264	274	235	449	
VSI 254/08/2B	RW12	220	300	3904	288	288	286	663	
VSI 254/08/1B	RW12	220	300	3904	288	288	286	663	
VSI 254/08	RW12	220	300	3904	288	288	286	663	
VSI 254/09/3B	RW12	220	300	4089	288	288	286	663	
VSI 254/09/2B	RW12	220	300	4089	288	288	286	663	
VSI 254/09/1B	RW12	250	340	4089	288	288	286	663	
VSI 254/09	RW12	250	340	4089	288	288	286	663	
VSI 254/10/3B	RW12	250	340	4274	288	288	286	663	
VSI 254/10/2B	RW12	250	340	4274	288	288	286	663	
VSI 254/10/1B	RW12	250	340	4274	288	288	286	663	
VSI 254/10	RW12	300	400	4424	288	288	286	726	
VSI 254/11/3B	RW12	300	400	4609	288	288	286	726	
VSI 254/11/2B	RW12	300	400	4609	288	288	286	726	
VSI 254/11/1B	RW12	300	400	4609	288	288	286	726	
VSI 254/11	RW12	300	400	4609	288	288	286	726	

⁽⁴⁾ ØD: maximum electropump diameter

⁽⁶⁾ Lengths without counterflange

⁽⁸⁾ Necessary kit P10xM6 (not included, Ref. n. 20.06, Code 14251020). Already included in length and weight values. For more information see page 43.

⁽⁹⁾ Not suitable for horizontal installation. Already included in length and weight values.

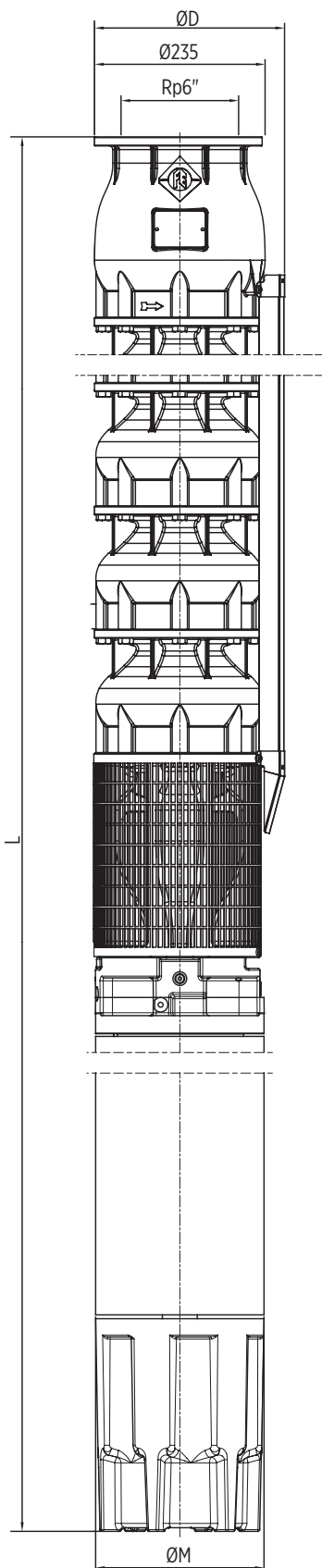

TECHNICAL DATA - PUMPS WITH REWINDABLE MOTORS

Pump model	Motor			Dimensions [mm]				Net weight [kg]	
	Type	[kW]	[HP]	L ⁽⁶⁾	ØD ⁽⁴⁾		ØM	Total	
				Motor	DOL	SD		PMA	
VSI 254/12/3B	RW12	300	400	4794	288	288	286	726	
VSI 254/12/2B	RW12	300	400	4794	288	288	286	726	
VSI 254/12/1B	RW12	300	400	4794	288	288	286	726	
VSI 254/12	RW12	350	470	4894	288	288	286	769	
VSI 254/13/3B	RW12	350	470	5079	288	288	286	769	
VSI 254/13/2B	RW12	350	470	5079	288	288	286	769	
VSI 254/13/1B	RW12	350	470	5079	288	288	286	769	
VSI 254/13	RW12	350	470	5079	288	288	286	769	
VSI 254/14/3B	RW12	350	470	5264	288	288	286	769	
VSI 254/14/2B	RW12	350	470	5264	288	288	286	769	

⁽⁴⁾ ØD: maximum electropump diameter

⁽⁶⁾ Lengths without counterflange

⁽⁸⁾ Necessary kit P10xM6 (not included, Ref. n. 20.06, Code 14251020). Already included in length and weight values. For more information see page 43.

⁽⁹⁾ Not suitable for horizontal installation. Already included in length and weight values.

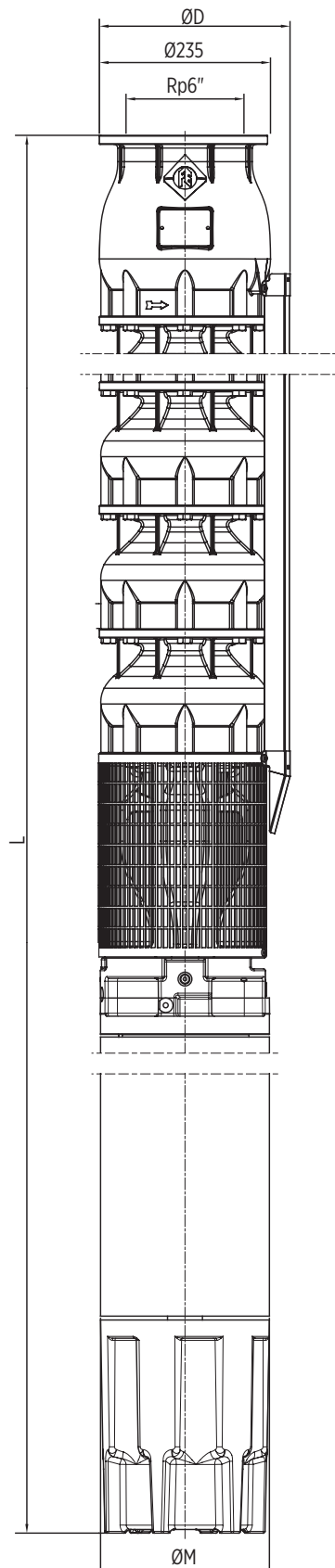

VSI 254 - PERFORMANCE CURVES AT 50 Hz

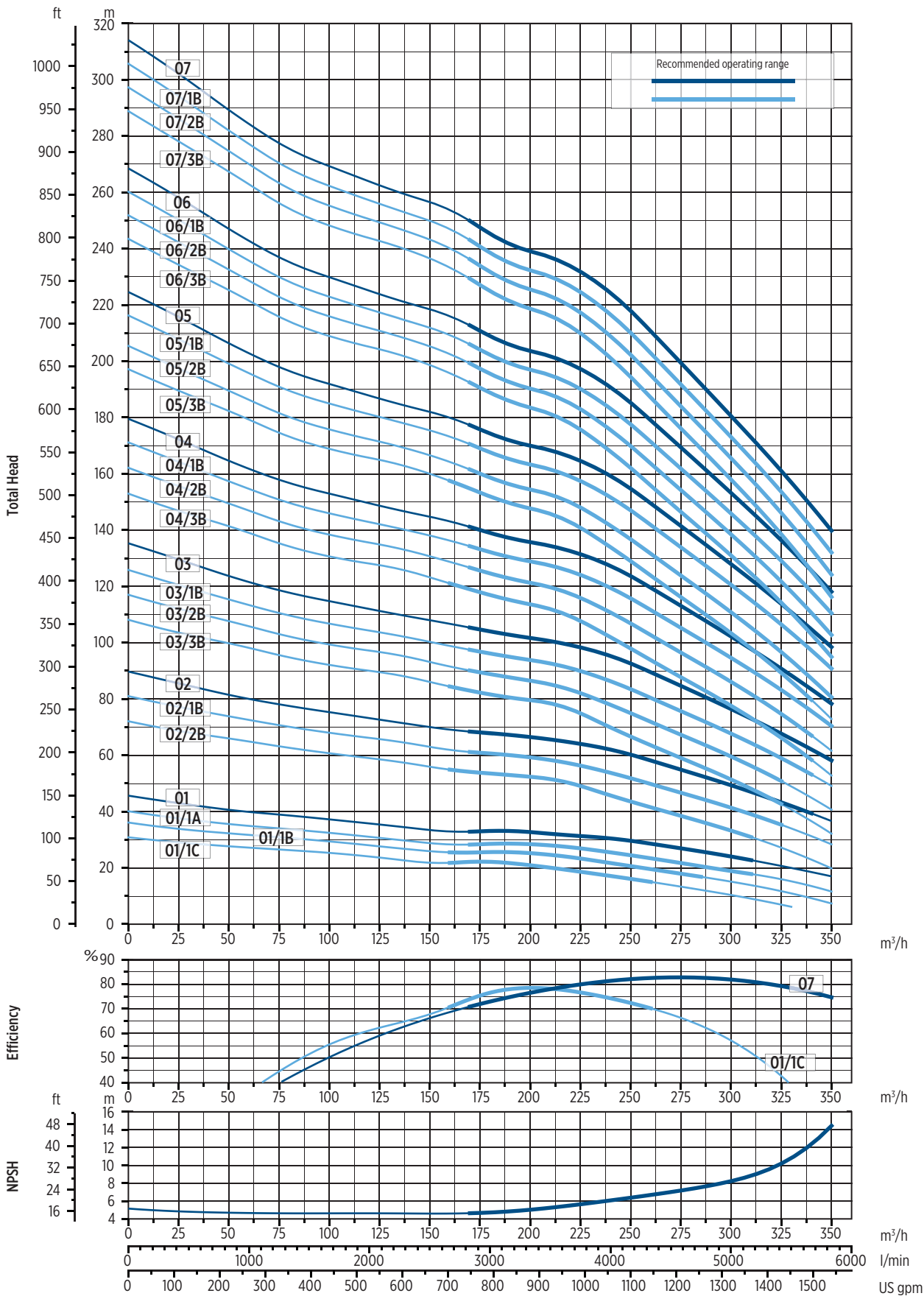

00/2025 05/2023

The hydraulic characteristics are guaranteed, according to ISO standard 9906:2012, grade 3B

VSI 254 - PERFORMANCE CURVES AT 50 Hz

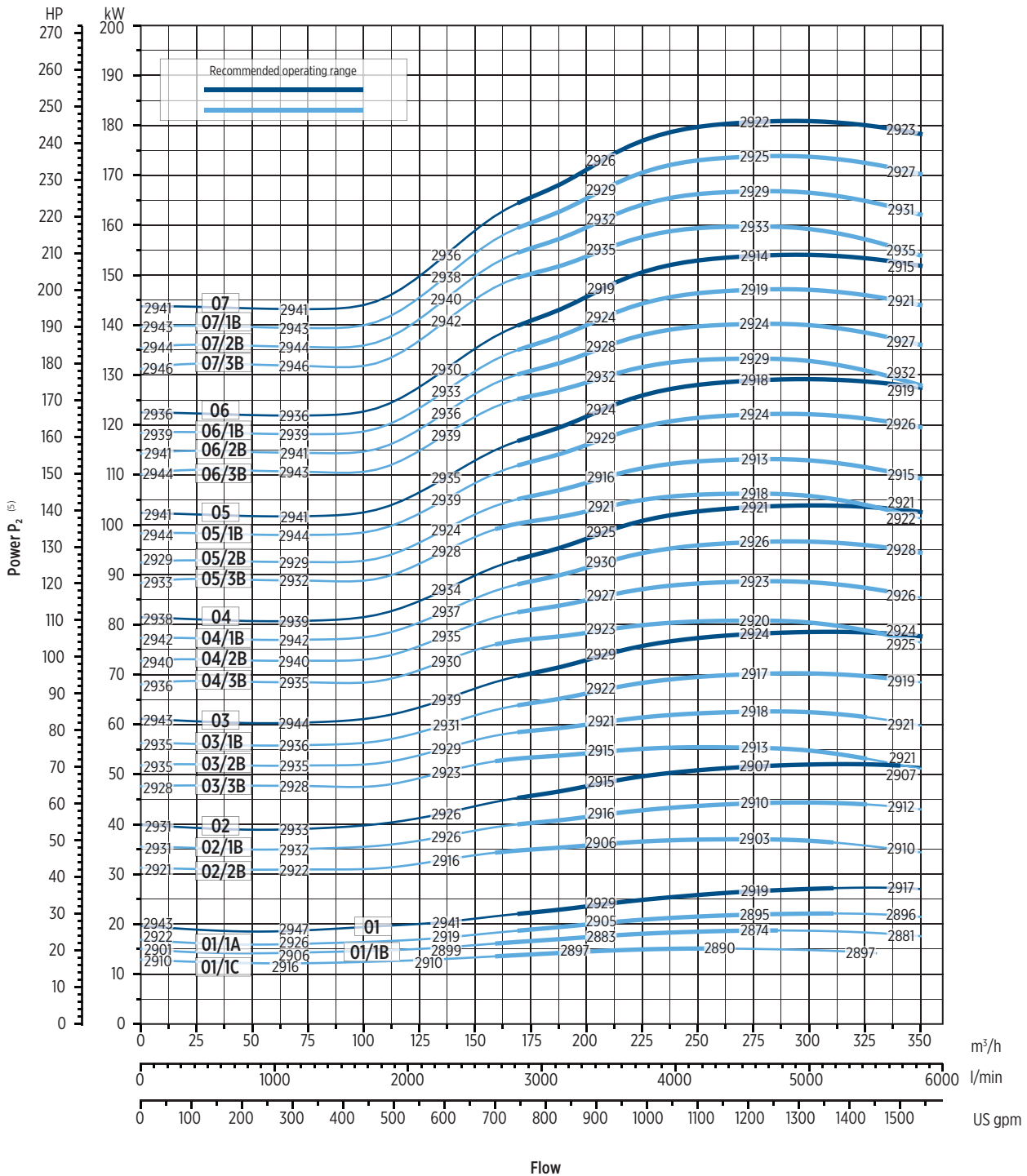

00120283-04/2023

⁽⁶⁾ Motor speed referred to rewindable motor

Performance curves (Q-H-P) will change according to the formulas above.
 Performance curves of Q, H and P depend on the rpm number according to the following formula:

$$Q_2 = Q_1 \cdot \left(\frac{n_2}{n_1}\right), \quad H_2 = H_1 \cdot \left(\frac{n_2}{n_1}\right)^2, \quad P_2 = P_1 \cdot \left(\frac{n_2}{n_1}\right)^3, \quad \eta \text{ remains approximately the same.}$$

The rpm number related to the performance curves (Q-H-P) is indicated in the power chart.
 Performance curves (Q-H-P) will change according to the formulas above.
 Q=Flow, H=Head, P=Power, η =Efficiency

The hydraulic characteristics are guaranteed, according to ISO standard 9906:2012, grade 3B

VSI 254 - PERFORMANCE CURVES AT 50 Hz

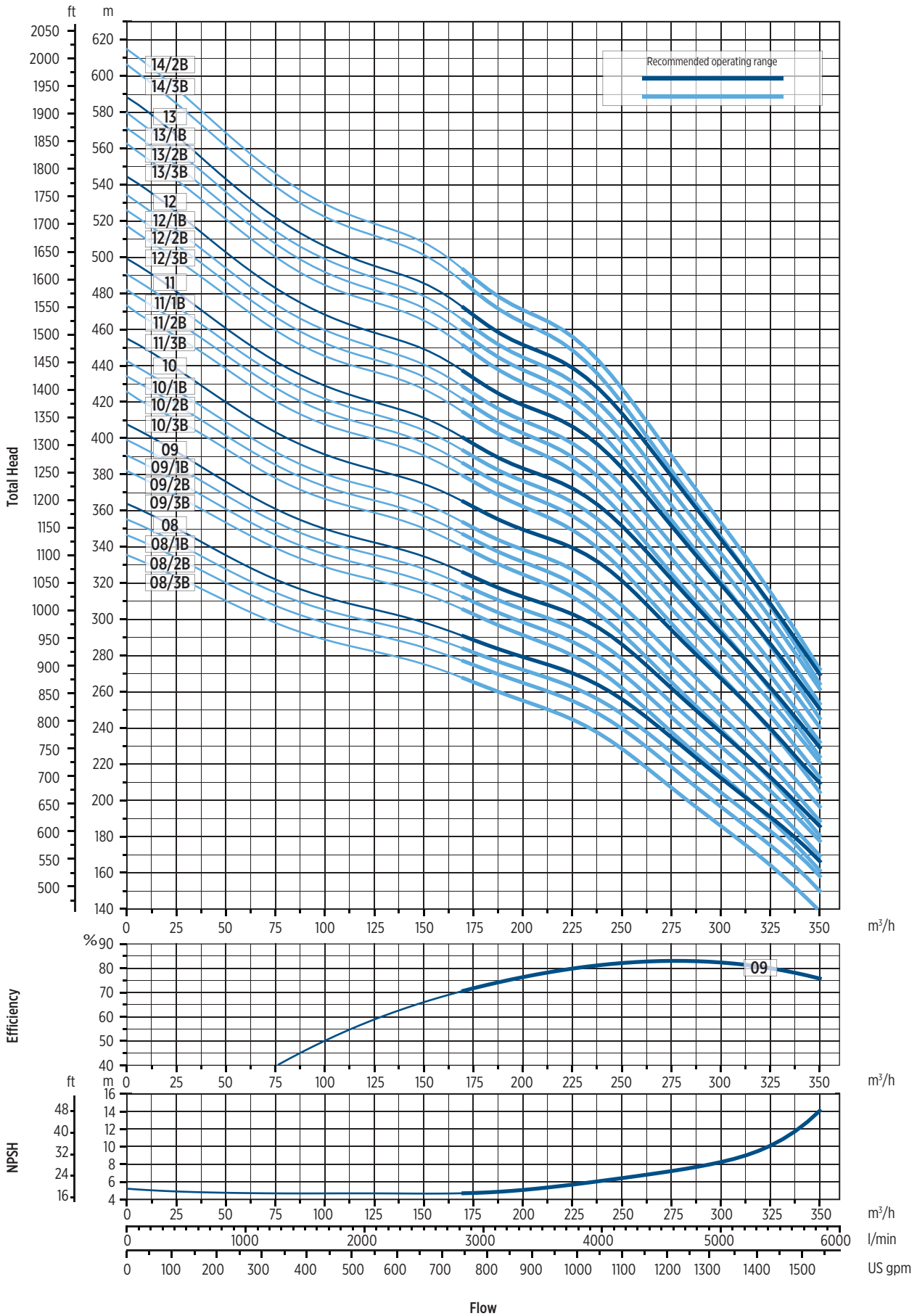

00/20294_05/2023

The hydraulic characteristics are guaranteed, according to ISO standard 9906:2012, grade 3B



VSI 254 - PERFORMANCE CURVES AT 50 Hz

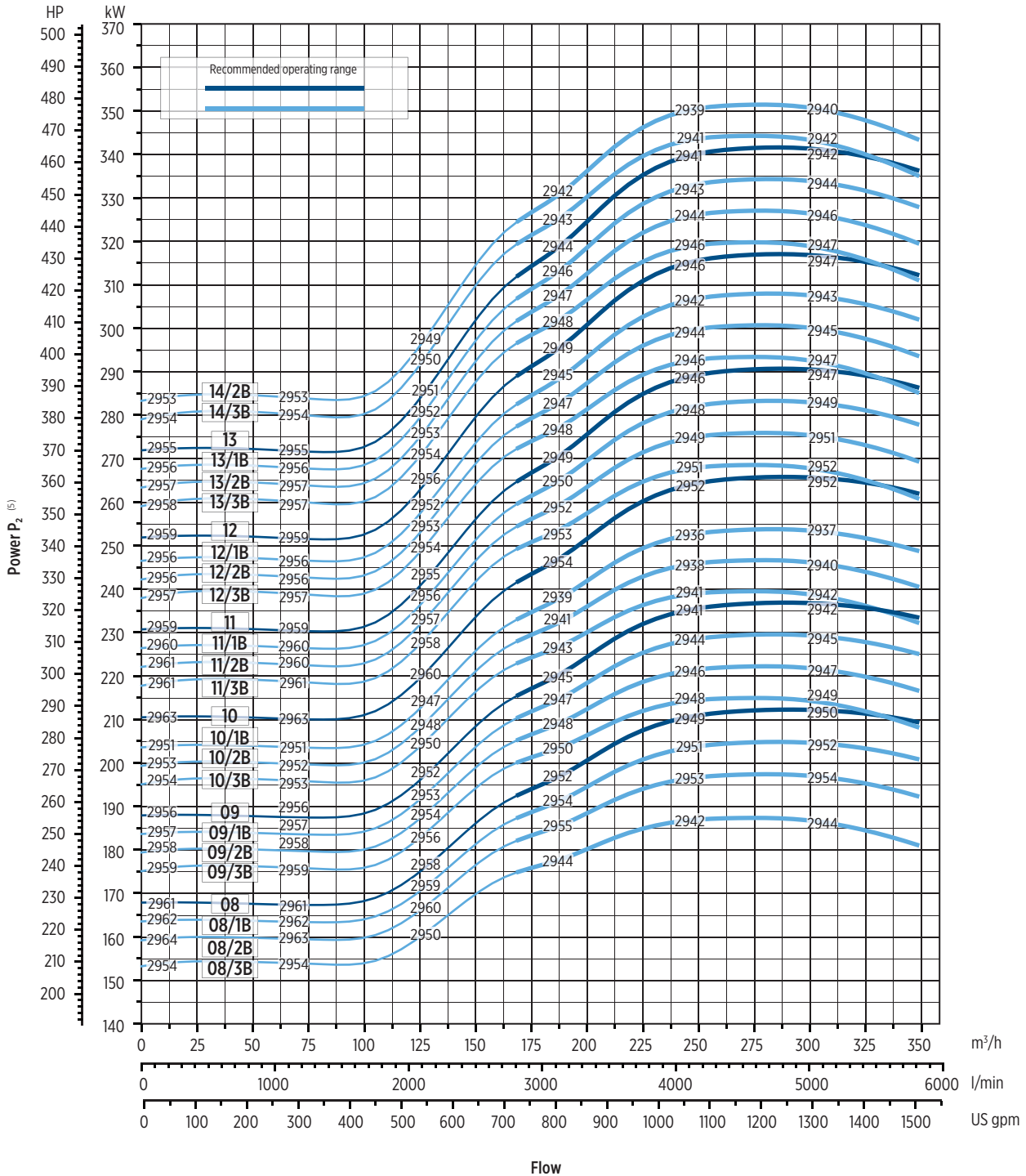

00120294-04/2023

⁽⁶⁾ Motor speed referred to rewindable motor

Performance curves (Q-H-P) will change according to the formulas above.
 Performance curves of Q, H and P depend on the rpm number according to the following formula:

$$Q_2 = Q_1 \cdot \left(\frac{n_2}{n_1}\right), \quad H_2 = H_1 \cdot \left(\frac{n_2}{n_1}\right)^2, \quad P_2 = P_1 \cdot \left(\frac{n_2}{n_1}\right)^3, \quad \eta \text{ remains approximately the same.}$$

The rpm number related to the performance curves (Q-H-P) is indicated in the power chart.
 Performance curves (Q-H-P) will change according to the formulas above.
 Q=Flow, H=Head, P=Power, η =Efficiency

The hydraulic characteristics are guaranteed, according to ISO standard 9906:2012, grade 3B



VSI 344 - 50 Hz

TECHNICAL DATA - PUMP END

Pump model	Motor bracket type	Cable guard type ⁽¹²⁾	Dimensions [mm]			Net weight [kg]
			L1	ØD1 ⁽⁹⁾		
				DOL	SD	Pump
VSI 344/01/1C	M8	L	815	297	302	84
VSI 344/01/1B	M8	L	815	297	302	845
VSI 344/01/1A	M8	L	815	297	302	85
VSI 344/01	M8	L	815	297	302	855
VSI 344/02/2B	M8	L	1025	297	302	1125
VSI 344/02/1B	M8	L	1025	297	302	1135
VSI 344/02	M8	L	1025	297	302	1145
VSI 344/02	M10	M	1025	304	313	1145
VSI 344/03/2B	M8	L	1235	297	302	142
VSI 344/03/1B	M10	M	1235	304	313	142
VSI 344/03/1B	M8	L	1235	297	302	143
VSI 344/03/1B	M10	M	1235	304	313	143
VSI 344/03	M10	M	1235	304	313	144
VSI 344/04/2B	M10	M	1445	304	313	171
VSI 344/04/1B	M12	M	1445	304	313	172
VSI 344/04	M12	M	1445	304	313	173
VSI 344/05/2B	M12	M	1655	304	313	200
VSI 344/05/1B	M12	M	1655	304	313	201
VSI 344/05	M12	M	1655	304	313	202
VSI 344/06/2B	M12	M	1865	304	313	290
VSI 344/06/1B	M12	M	1865	304	313	230
VSI 344/06	M12	M	1865	304	313	231
VSI 344/07/2B	M12	M	2075	304	313	258
VSI 344/07/1B	M12	M	2075	304	313	259

⁽⁹⁾ ØD1: maximum pump diameter.

⁽⁷⁾ Pump with kit motor adapter. Already included in length and weight values.. For more information see page 42.

⁽¹²⁾ Low (L); Medium (M); High (H). For more information see page 44.

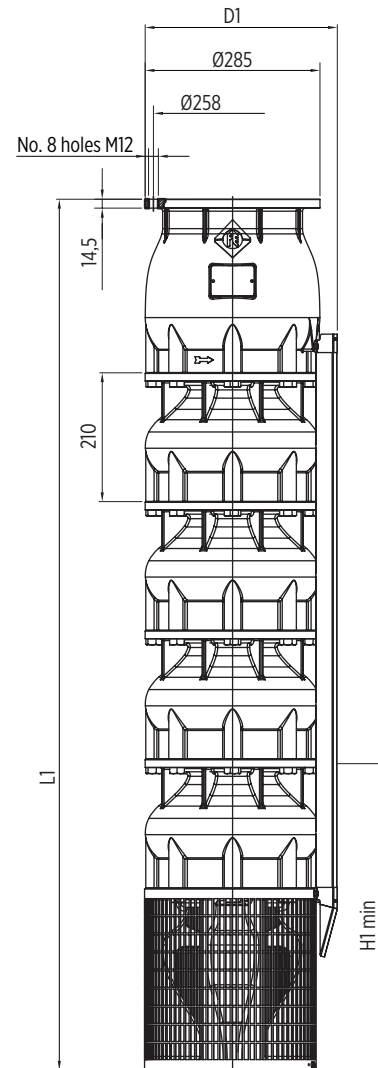

0013035012/2023

VSI 344 - 50 Hz

TECHNICAL DATA - PUMPS WITH ENCAPSULATED MOTORS

Pump model	Motor			Dimensions [mm]				Net weight [kg]	
	Type	[kW]	[HP]	L ⁽⁶⁾	ØD ⁽⁴⁾		ØM	Total	
				Motor	DOL	SD		PMA	
VSI 344/01/1C	CT8	30	40	1740	297	302	191	117	
VSI 344/01/1B	CT8	37	50	1815	297	302	191	131	
VSI 344/01/1A	CT8	45	60	1892	297	302	191	143	
VSI 344/01	CT8	55	75	2079	297	302	191	196	
VSI 344/02/2B	CT8	75	100	2480	297	302	191	232	
VSI 344/02/1B	CT8	93	125	2773	297	302	191	290	
VSI 344/02	CT8	110	150	3001	297	302	191	334	
VSI 344/03/2B	CT8	130	175	3414	297	302	191	380	
VSI 344/03/1B	CT8	150	200	3643	297	302	191	429	

⁽⁴⁾ ØD: maximum electropump diameter.

⁽⁶⁾ Lengths without counterflange.

⁽⁸⁾ Necessary kit P10xM6 (not included, Ref. n. 20.06, Code 14251020). Already included in length and weight values. For more information see page 43.

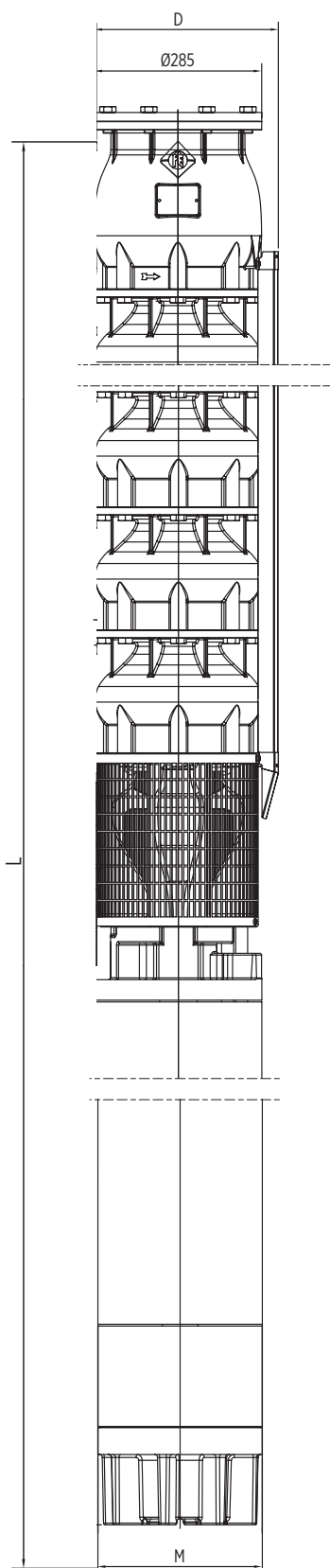

VSI 344 - 50 Hz

TECHNICAL DATA - PUMPS WITH REWINDABLE MOTORS

Pump model	Motor			Dimensions [mm]				Net weight [kg]	
	Type	[kW]	[HP]	L	ØD ⁽⁴⁾		ØM	Total	
				Motor	DOL	SD		PMA	
VSI 344/01/1C	RW8	30	40	1955	297	302	194	140	
VSI 344/01/1B	RW8	37	50	1955	297	302	194	140	
VSI 344/01/1A	RW8	45	60	2045	297	302	194	156	
VSI 344/01	RW8	55	75	2155	297	302	194	179	
VSI 344/02/2B	RW8	75	100	2585	297	302	194	215	
VSI 344/02/1B	RW8 ⁽⁹⁾	93	125	2765	297	302	194	247	
VSI 344/02	RW10	110	150	2444	304	313	235	280	
VSI 344/03/2B	RW10	130	175	2894	304	313	235	362	
VSI 344/03/1B	RW10	150	200	3004	304	313	235	413	
VSI 344/03	RW10 ⁽⁹⁾	185	250	3154	304	313	235	449	
VSI 344/04/2B	RW10 ⁽⁹⁾	185	250	3364	304	313	235	449	
VSI 344/04/1B	RW12	220	300	3338	309	316	286	663	
VSI 344/04	RW12	220	300	3338	309	316	286	663	
VSI 344/05/2B	RW12	250	340	3548	309	316	286	663	
VSI 344/05/1B	RW12	250	340	3548	309	316	286	663	
VSI 344/05	RW12	300	400	3698	309	316	286	726	
VSI 344/06/2B	RW12	300	400	3908	309	316	286	2043	
VSI 344/06/1B	RW12	300	400	3908	309	316	286	2043	
VSI 344/06	RW12	350	470	4008	309	316	286	769	
VSI 344/07/2B	RW12	350	470	4218	309	316	286	2143	
VSI 344/07/1B	RW12	350	470	4218	309	316	286	2143	

⁽⁴⁾ ØD: maximum electropump diameter.

⁽⁸⁾ Necessary kit P10xM6 (not included, Ref. n. 20.06, Code 14251020). Already included in length and weight values. For more information see page 43.

⁽⁹⁾ Not suitable for horizontal installation. Already included in length and weight values.

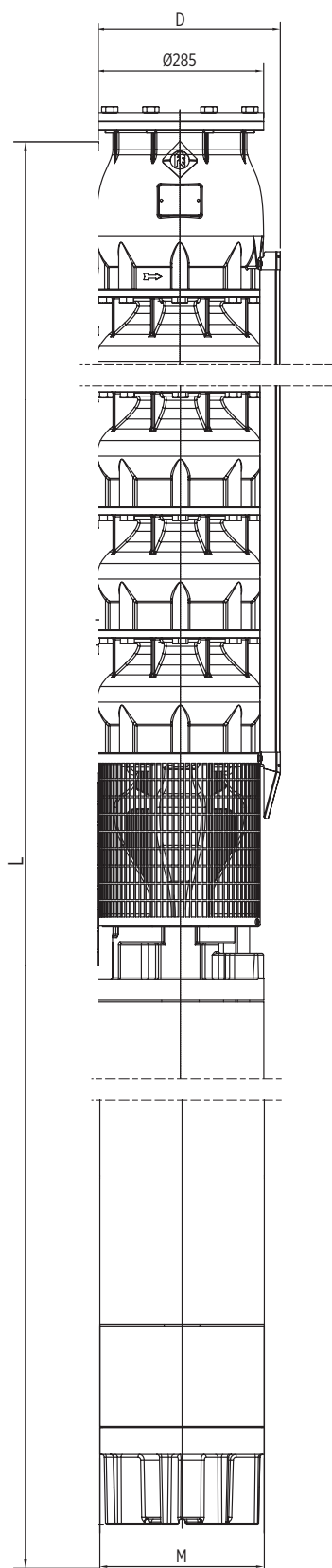

VSI 344 - PERFORMANCE CURVES AT 50 Hz

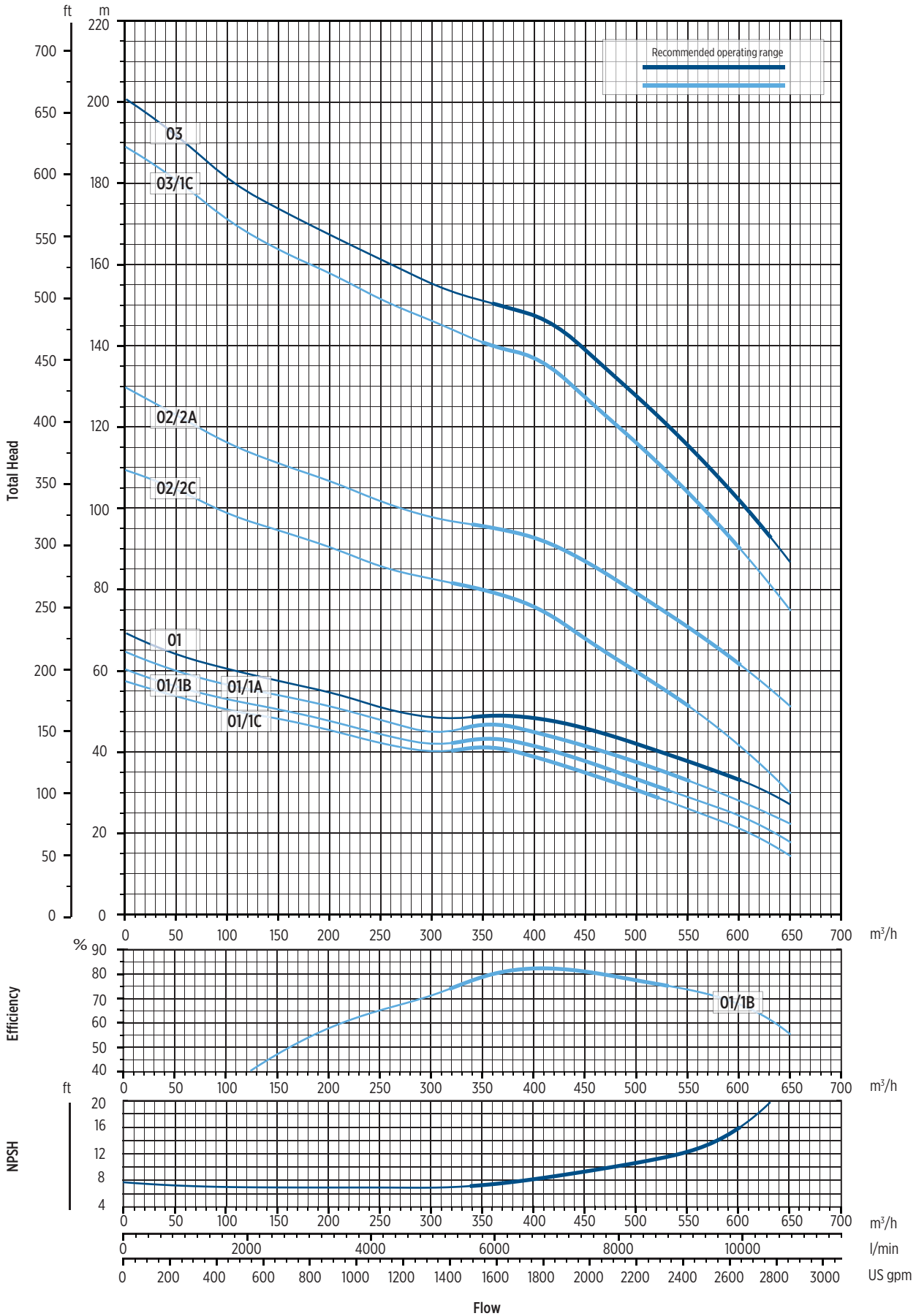

The hydraulic characteristics are guaranteed, according to ISO standard 9906:2012, grade 3B

0020299 05/2024

VSI 344 - PERFORMANCE CURVES AT 50 Hz

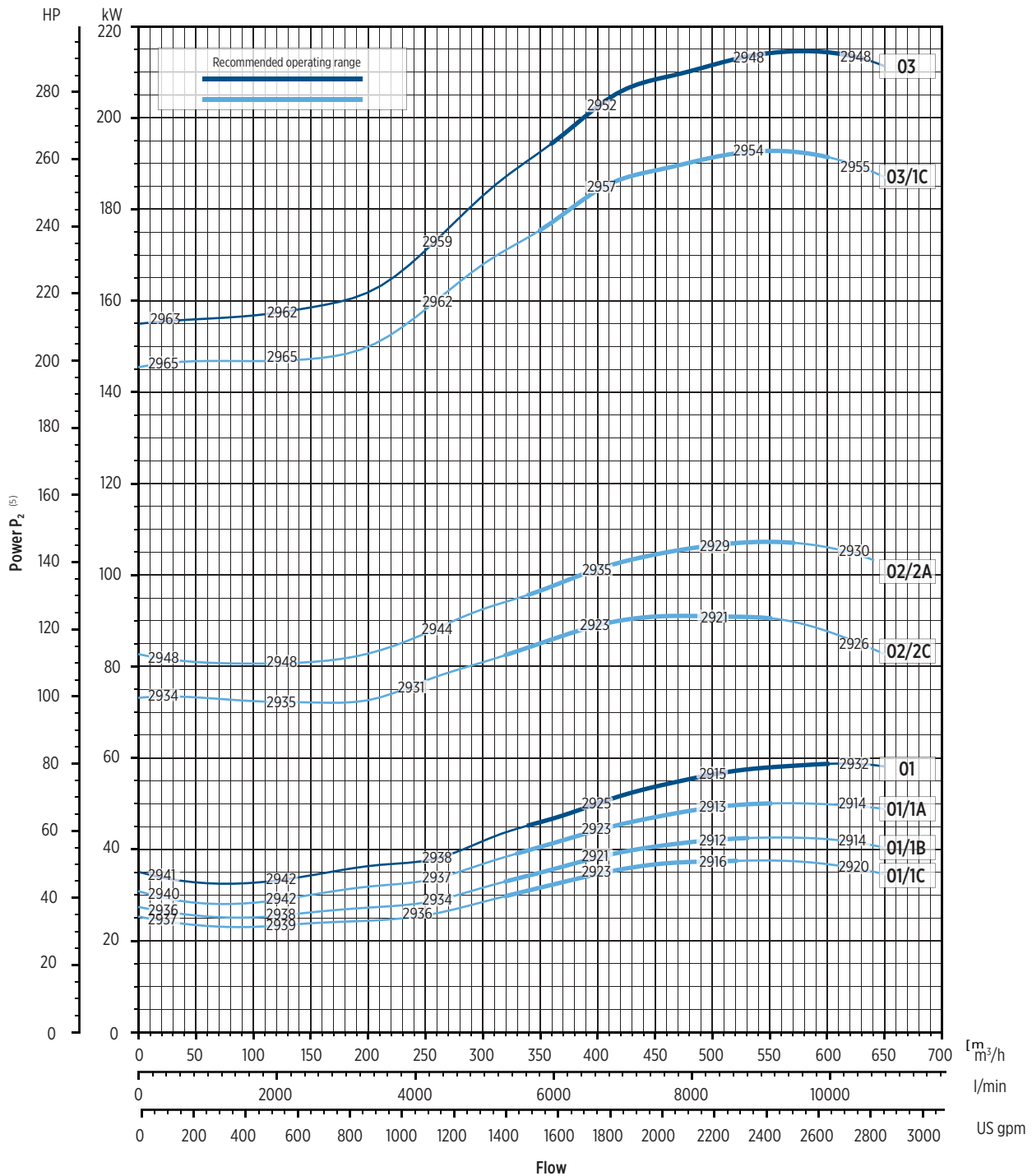

00120295 05/2024

⁽⁶⁾ Motor speed referred to rewindable motor

Performance curves (Q-H-P) will change according to the formulas above.
 Performance curves of Q, H and P depend on the rpm number according to the following formula:

$$Q_2 = Q_1 \cdot \left(\frac{n_2}{n_1}\right), \quad H_2 = H_1 \cdot \left(\frac{n_2}{n_1}\right)^2, \quad P_2 = P_1 \cdot \left(\frac{n_2}{n_1}\right)^3, \quad \eta \text{ remains approximately the same.}$$

The rpm number related to the performance curves (Q-H-P) is indicated in the power chart.
 Performance curves (Q-H-P) will change according to the formulas above.
 Q=Flow, H=Head, P=Power, η=Efficiency

The hydraulic characteristics are guaranteed, according to ISO standard 9906:2012, grade 3B

VSI 344 - PERFORMANCE CURVES AT 50 Hz

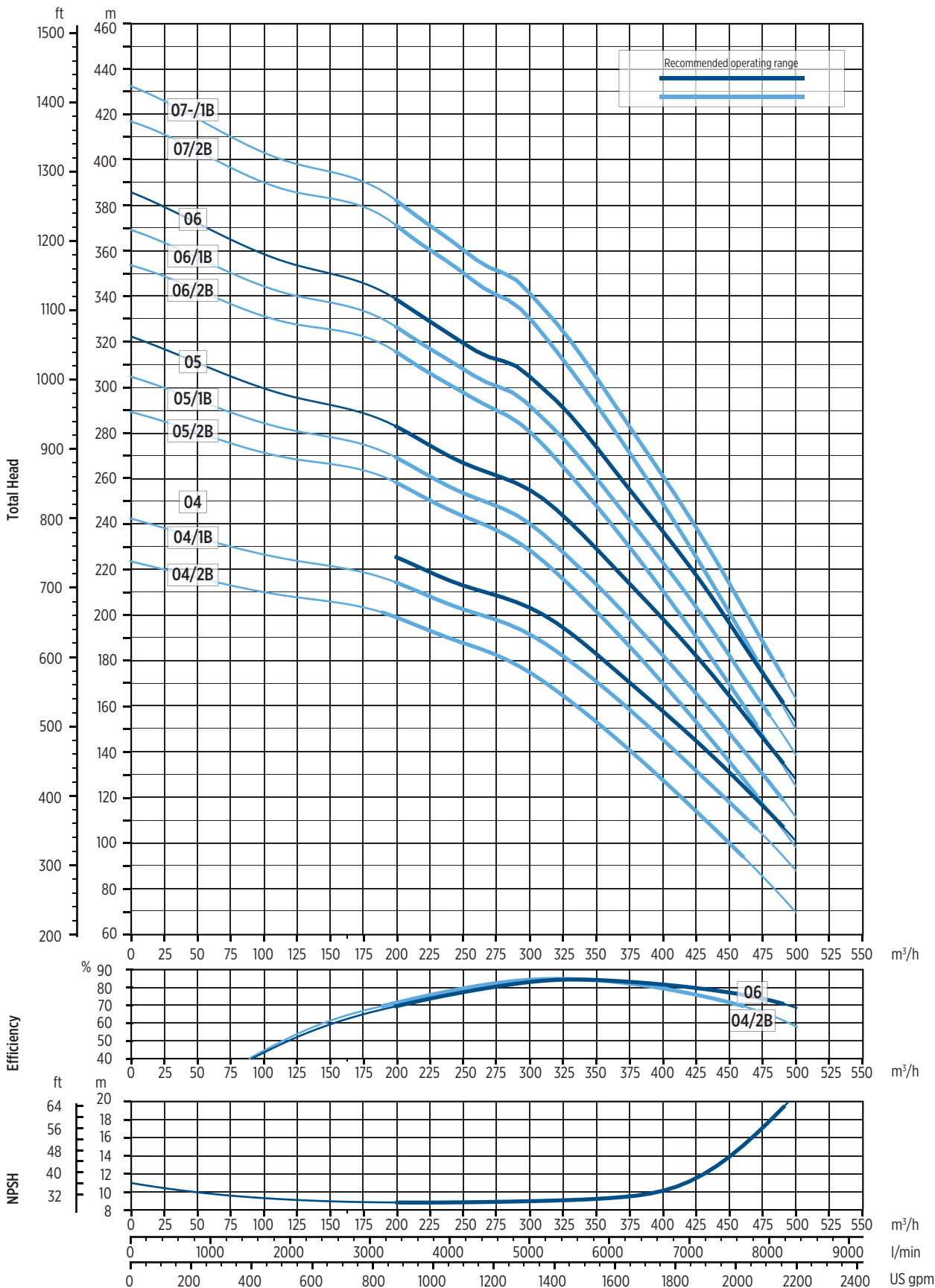

00120298 12/2023

Flow

The hydraulic characteristics are guaranteed, according to ISO standard 9906:2012, grade 3B

VSI 344 - PERFORMANCE CURVES AT 50 Hz

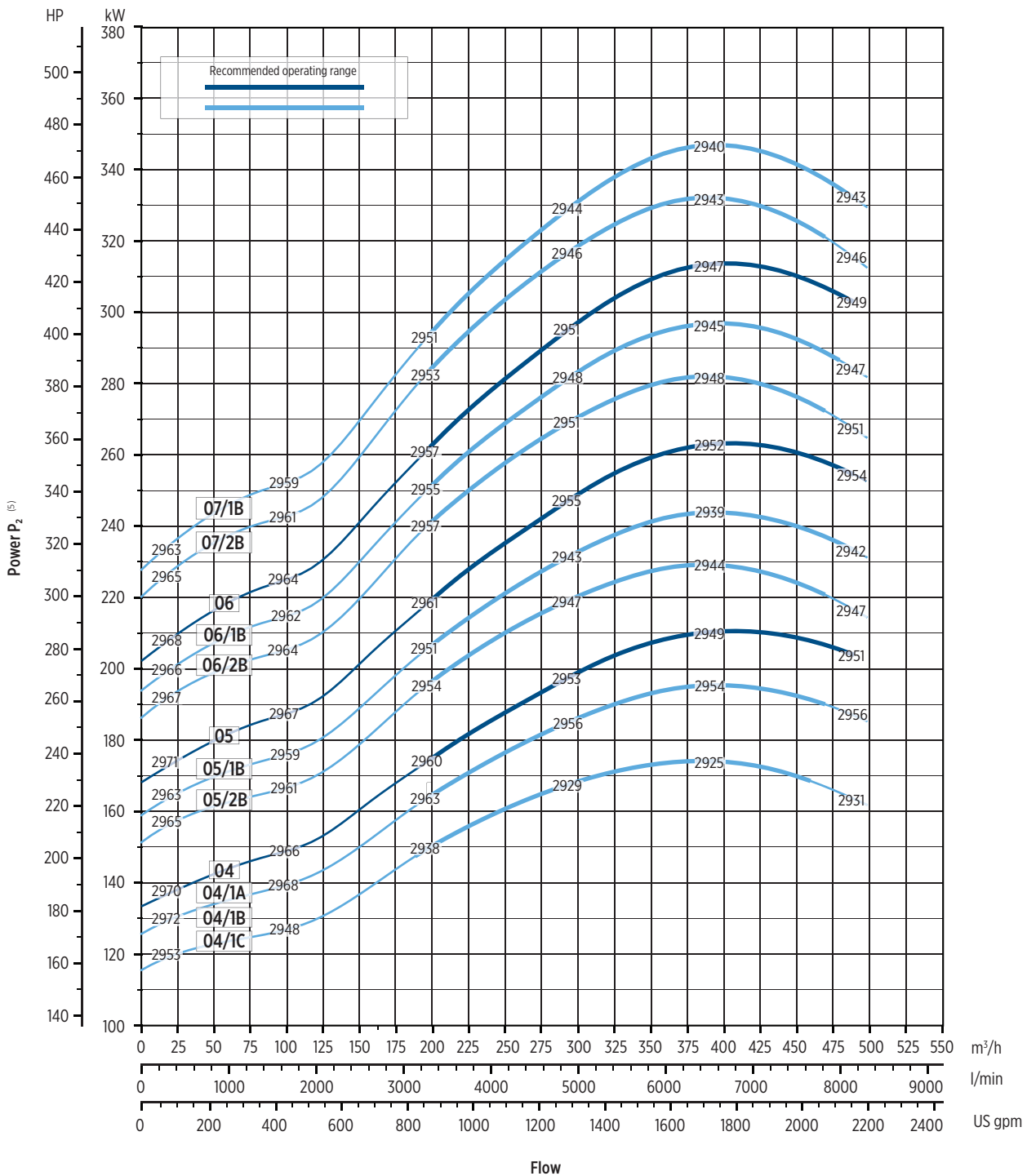

00720298 12/2023

⁽⁶⁾ Motor speed referred to rewindable motor

Performance curves (Q-H-P) will change according to the formulas above.
 Performance curves of Q, H and P depend on the rpm number according to the following formula:

$$Q_2 = Q_1 \cdot \left(\frac{n_2}{n_1}\right), \quad H_2 = H_1 \cdot \left(\frac{n_2}{n_1}\right)^2, \quad P_2 = P_1 \cdot \left(\frac{n_2}{n_1}\right)^3, \quad \eta \text{ remains approximately the same.}$$

The rpm number related to the performance curves (Q-H-P) is indicated in the power chart.
 Performance curves (Q-H-P) will change according to the formulas above.
 Q=Flow, H=Head, P=Power, η =Efficiency

The hydraulic characteristics are guaranteed, according to ISO standard 9906:2012, grade 3B

VSI 454 - 50 Hz

TECHNICAL DATA - PUMP END

Pump model	Motor bracket type	Cable guard type ⁽¹²⁾	Dimensions [mm]			Net weight [kg]
			L1	ØD1 ⁽³⁾		
				DOL	SD	Pump
VSI 454/01-1F	M8	L	835	297	302	84,5
VSI 454/01-1E	M8	L	835	297	302	85
VSI 454/01-1D	M8	L	835	297	302	85
VSI 454/01-1C	M8	L	835	297	302	85,5
VSI 454/01	M8	L	835	297	302	86
VSI 454/02-2C	M8	L	1065	297	302	114,5
VSI 454/02-1A	M8	L	1065	297	302	115,5
VSI 454/02-1A	M10	M	1065	304	313	115,5
VSI 454/03-1C	M12	M	1295	304	313	144,5
VSI 454/03	M12	M	1295	304	313	145
VSI 454/04-1B	M12	M	1525	304	313	174
VSI 454/04	M12	M	1525	304	313	174,5

⁽³⁾ ØD1: maximum pump diameter.

⁽⁷⁾ Pump with kit motor adapter. Already included in length and weight values.. For more information see page 42.

⁽¹²⁾ Low (L); Medium (M); High (H). For more information see page 44.

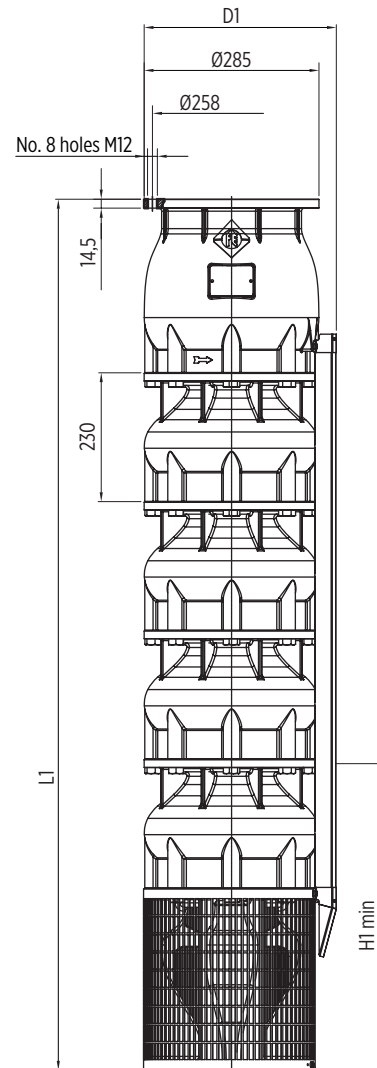

00130351 05/2024

VSI 454 - 50 Hz

TECHNICAL DATA - PUMPS WITH ENCAPSULATED MOTORS

Pump model	Motor			Dimensions [mm]				Net weight [kg]	
	Type	[kW]	[HP]	L ⁽⁶⁾	ØD ⁽⁴⁾		ØM	Total	
				Motor	DOL	SD		PMA	
VSI 454/01-1C	CT8	55	75	2099	297	302	191	196	
VSI 454/01-1B	CT8	75	100	2290	297	302	191	232	
VSI 454/01-1A	CT8	75	100	2290	297	302	191	232	
VSI 454/01	CT8	75	100	2290	297	302	191	232	
VSI 454/02-2C	CT8	110	150	3041	297	302	191	334	
VSI 454/02-1A	CT8	110	150	3041	297	302	191	334	

⁽⁴⁾ ØD: maximum electropump diameter.

⁽⁶⁾ Lengths without counterflange.

⁽⁸⁾ Necessary kit P10xM6 (not included, Ref. n. 20.06, Code 14251020). Already included in length and weight values. For more information see page 43.

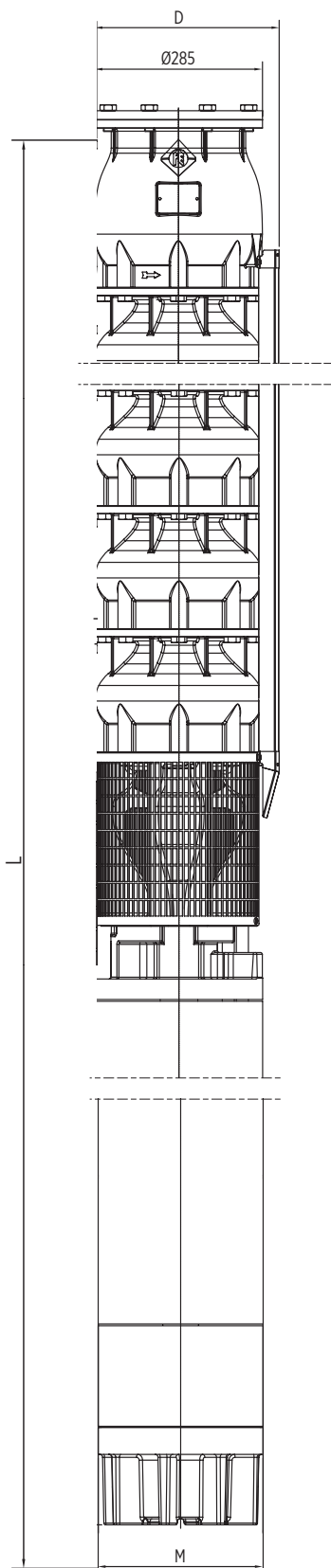

VSI 454 - 50 Hz

TECHNICAL DATA - PUMPS WITH REWINDABLE MOTORS

Pump model	Motor			Dimensions [mm]				Net weight [kg]
	Type	[kW]	[HP]	L	ØD ⁽⁴⁾		ØM	Total
				Motor	DOL	SD		PMA
VSI 454/01-1C	RW8	55	75	2175	297	302	194	179
VSI 454/01-1B	RW8	60	80	2305	297	302	194	198
VSI 454/01-1A	RW8	67	90	2305	297	302	194	198
VSI 454/01	RW8	75	100	2395	297	302	194	215
VSI 454/02-2C	RW10	110	150	2594	304	313	235	315
VSI 454/02-1A	RW10	150	200	2834	304	313	235	413
VSI 454/03-1C	RW12	220	300	3188	309	316	286	663
VSI 454/03	RW12	220	300	3188	309	316	286	663
VSI 454/04-1B	RW12	300	400	3568	309	316	286	726
VSI 454/04	RW12	300	400	3568	309	316	286	726

⁽⁴⁾ ØD: maximum electropump diameter.

⁽⁸⁾ Necessary kit P10xM6 (not included, Ref. n. 20.06, Code 14251020). Already included in length and weight values. For more information see page 43.

⁽⁹⁾ Not suitable for horizontal installation. Already included in length and weight values.

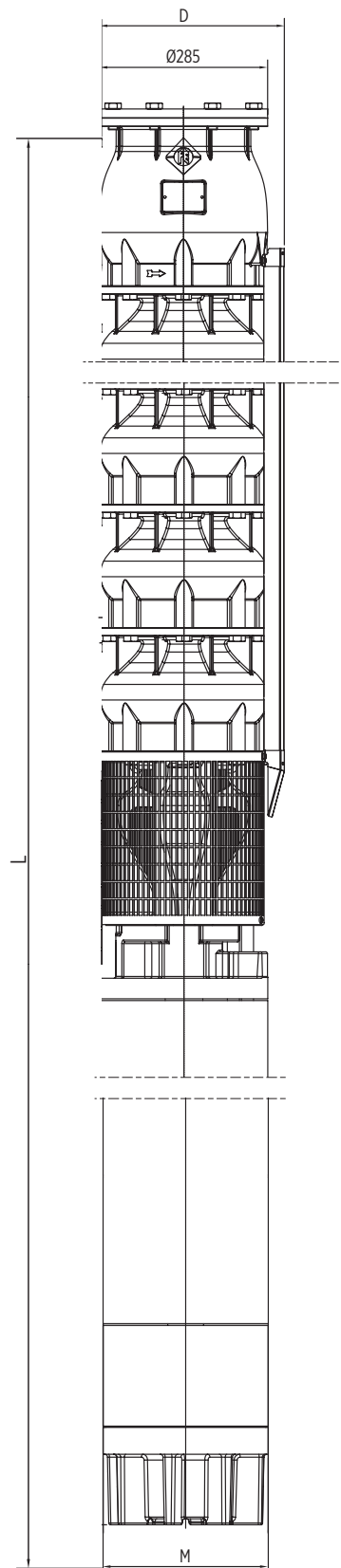

VSI 454 - PERFORMANCE CURVES AT 50 Hz

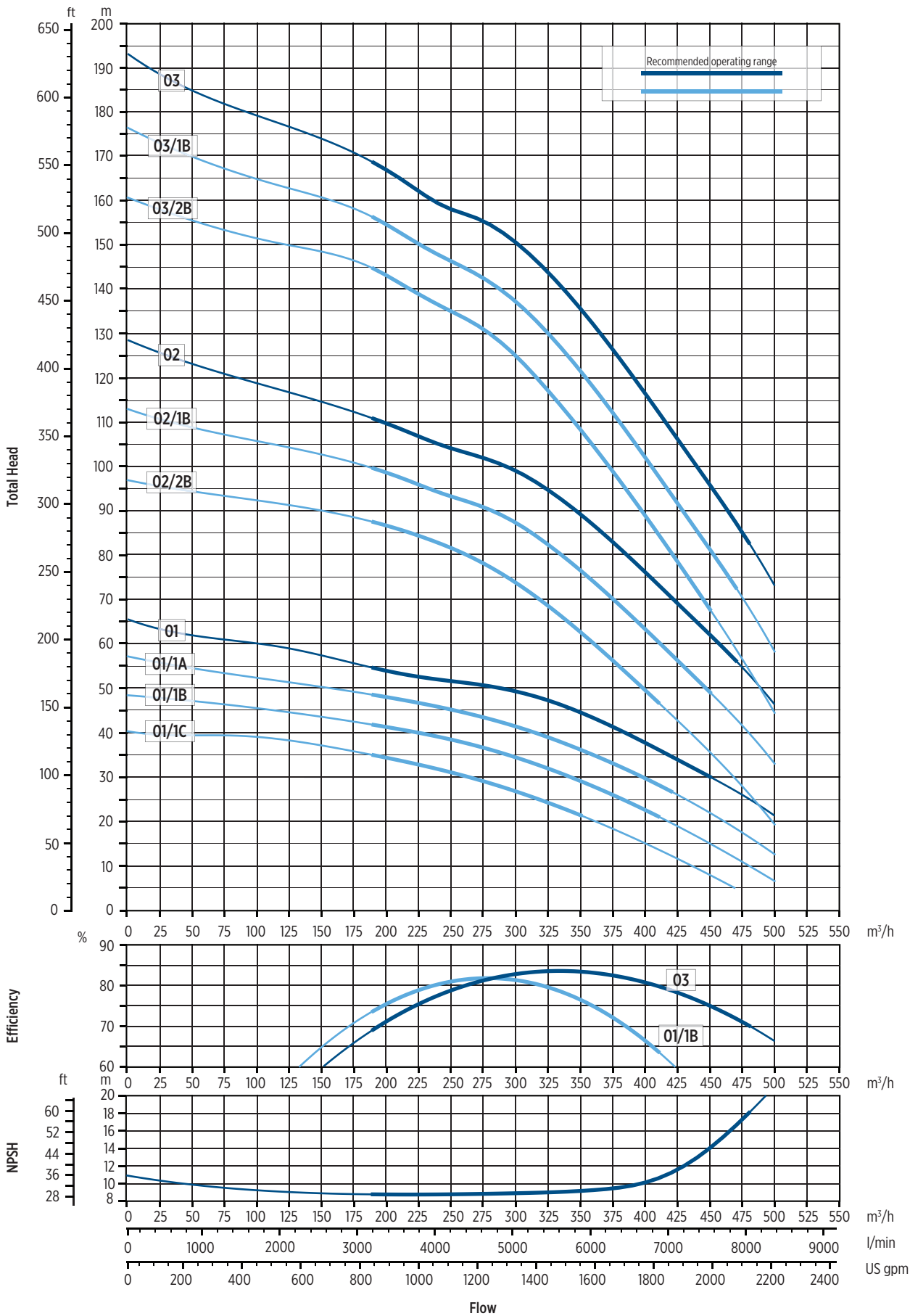

The hydraulic characteristics are guaranteed, according to ISO standard 9906:2012, grade 3B

00102917 12/2023

VSI 454 - PERFORMANCE CURVES AT 50 Hz

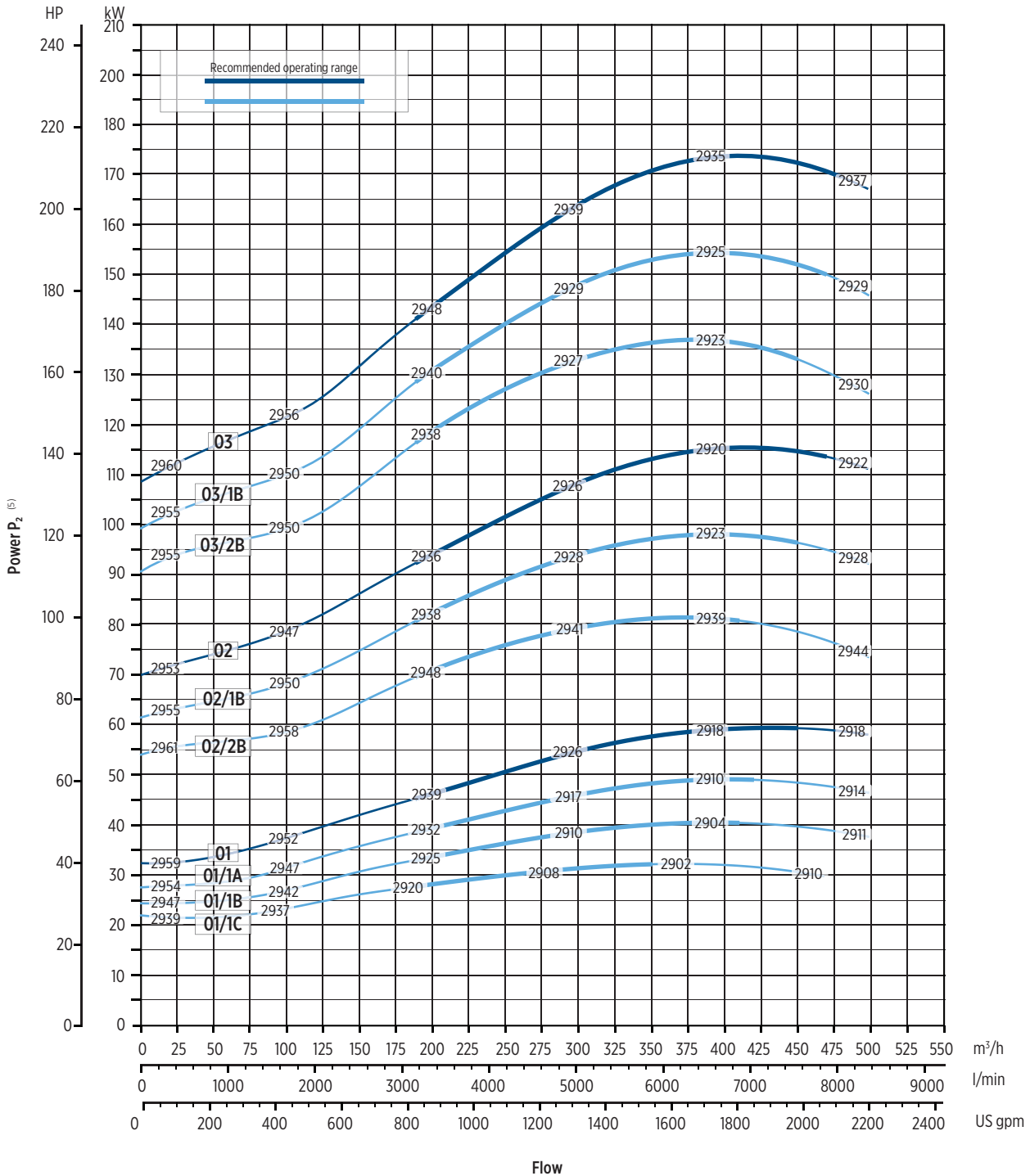

⁽⁶⁾ Motor speed referred to rewindable motor

Performance curves (Q-H-P) will change according to the formulas above.
Performance curves of Q, H and P depend on the rpm number according to the following formula:

$$Q_2 = Q_1 \cdot \left(\frac{n_2}{n_1}\right), \quad H_2 = H_1 \cdot \left(\frac{n_2}{n_1}\right)^2, \quad P_2 = P_1 \cdot \left(\frac{n_2}{n_1}\right)^3, \quad \eta \text{ remains approximately the same.}$$

The rpm number related to the performance curves (Q-H-P) is indicated in the power chart.
Performance curves (Q-H-P) will change according to the formulas above.
Q=Flow, H=Head, P=Power, η =Efficiency

The hydraulic characteristics are guaranteed, according to ISO standard 9906:2012, grade 3B

VSI 454 - PERFORMANCE CURVES AT 50 Hz

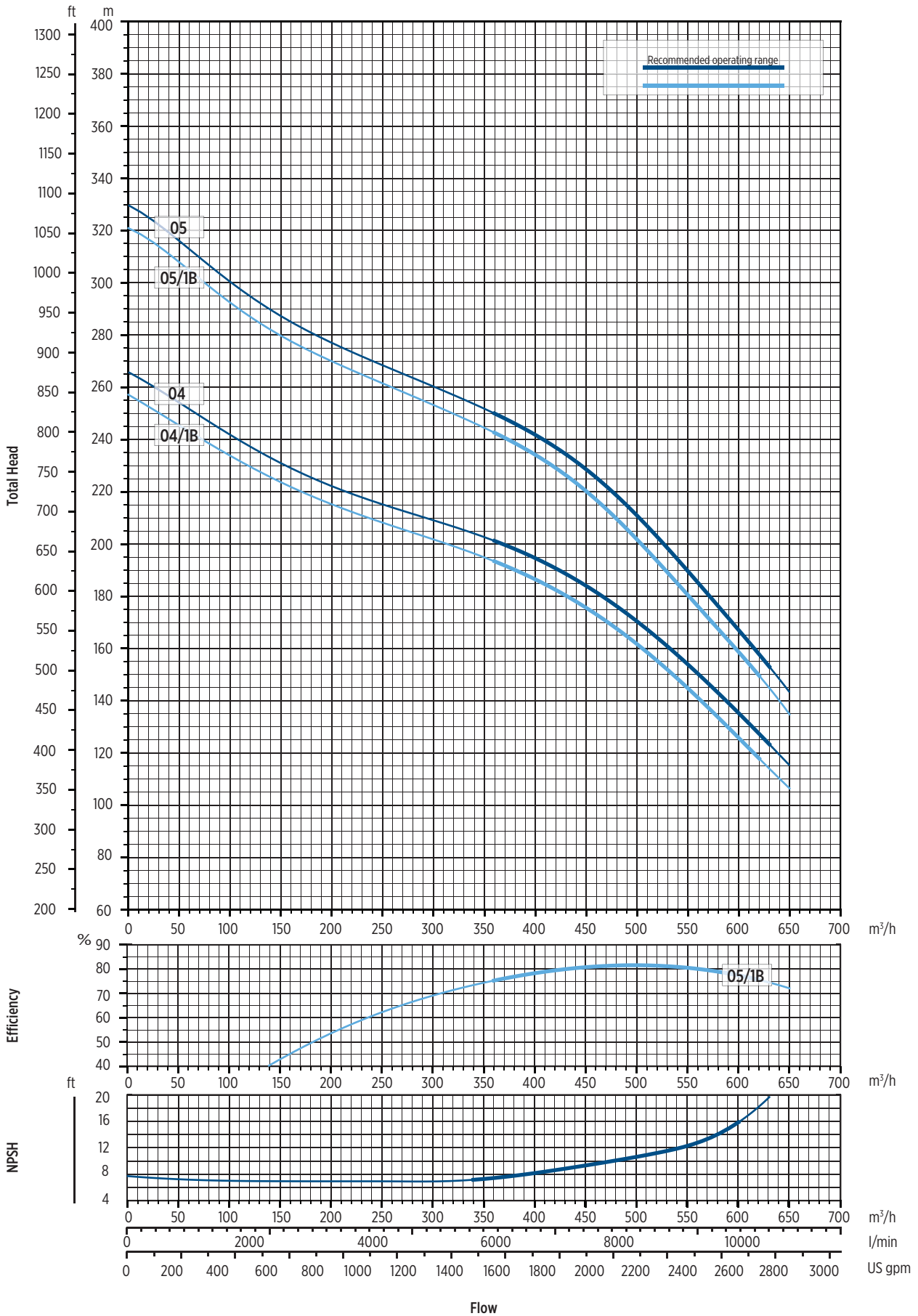

0020300 05/2024

The hydraulic characteristics are guaranteed, according to ISO standard 9906:2012, grade 3B

VSI 454 - PERFORMANCE CURVES AT 50 Hz

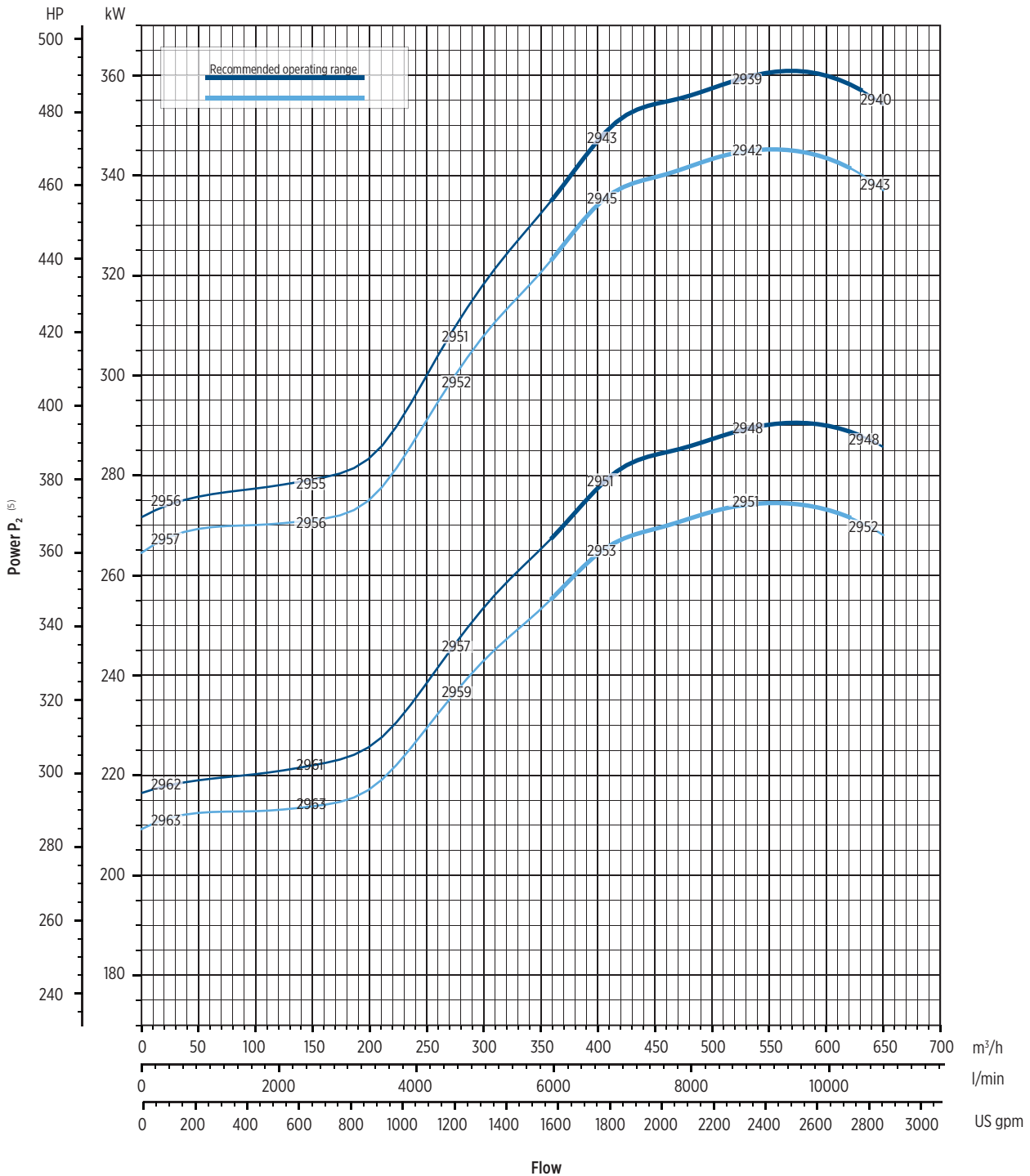

00103300 05/2024

⁽⁶⁾ Motor speed referred to rewindable motor

Performance curves (Q-H-P) will change according to the formulas above.
 Performance curves of Q, H and P depend on the rpm number according to the following formula:

$$Q_2 = Q_1 \cdot \left(\frac{n_2}{n_1}\right), \quad H_2 = H_1 \cdot \left(\frac{n_2}{n_1}\right)^2, \quad P_2 = P_1 \cdot \left(\frac{n_2}{n_1}\right)^3, \quad \eta \text{ remains approximately the same.}$$

The rpm number related to the performance curves (Q-H-P) is indicated in the power chart.
 Performance curves (Q-H-P) will change according to the formulas above.
 Q=Flow, H=Head, P=Power, η =Efficiency

The hydraulic characteristics are guaranteed, according to ISO standard 9906:2012, grade 3B

MOTOR BRACKETS

VSI 8"

6" MOTOR

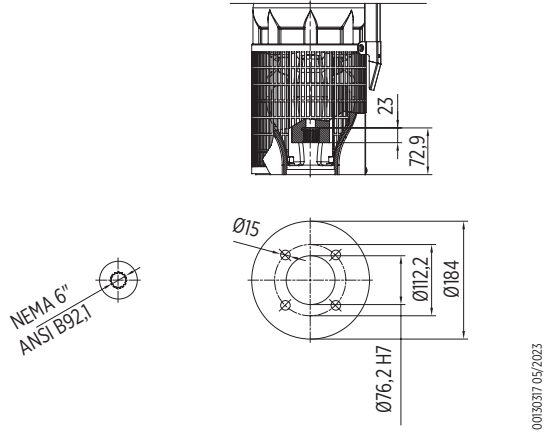

8" MOTOR

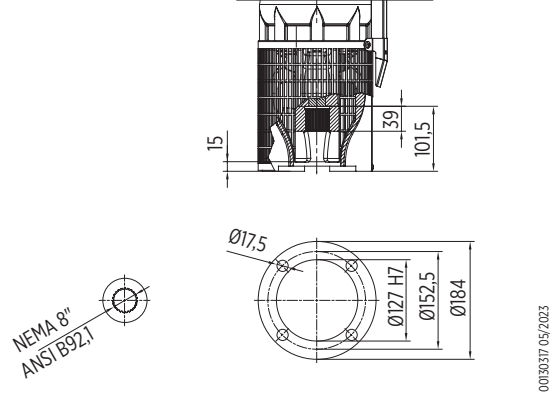

10" MOTOR

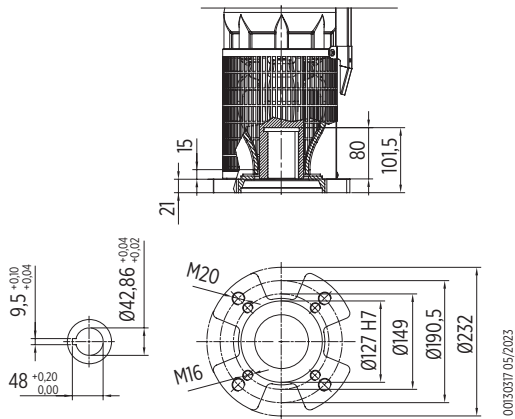

MOTOR BRACKETS

VSI 10"

6" MOTOR ⁽¹⁰⁾

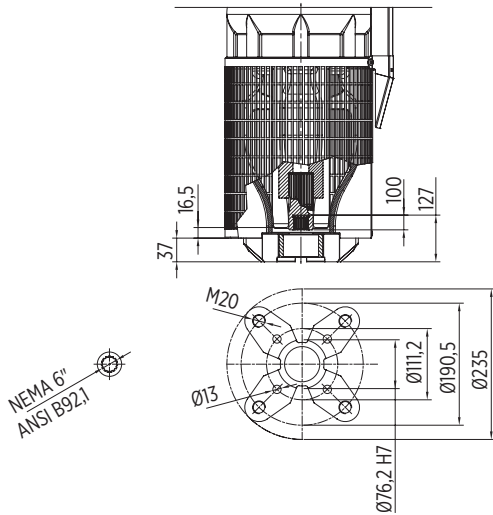

00130318 05/2023

8" MOTOR

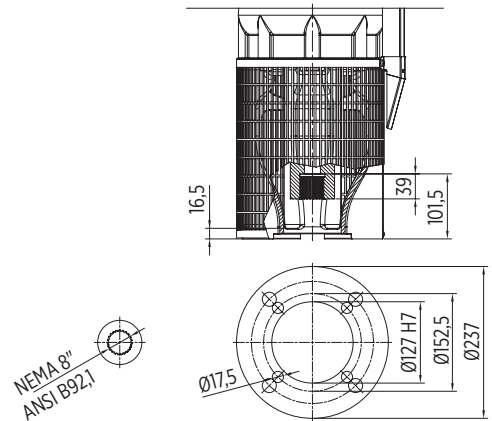

00130318 05/2023

⁽¹⁰⁾ Necessary kit P10xM6 (not included, Ref. n. 20.06, Code 14251020).

10" MOTOR

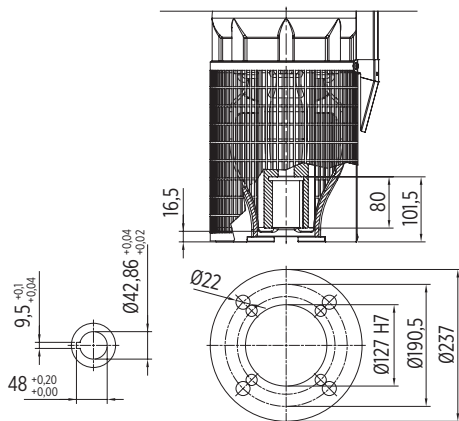

00130318 05/2023

12" MOTOR

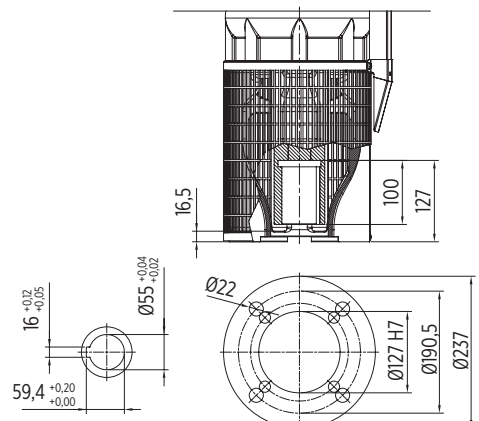

00130318 05/2023

MOTOR BRACKETS

VSI 12"

8" MOTOR

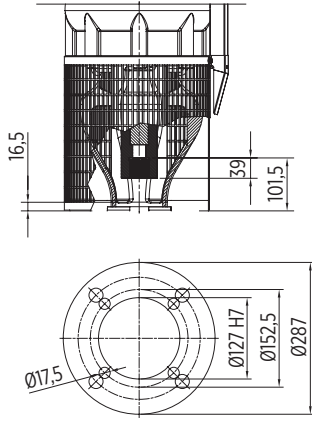

NEMA 8"
ANSI B92.1

00130333.12/2023

10" MOTOR

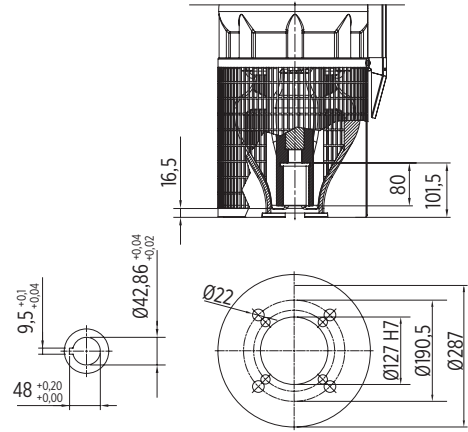

00130333.12/2023

12" MOTOR

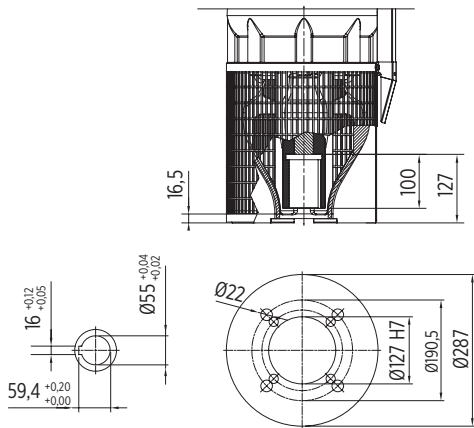

00130333.12/2023

COUNTERFLANGES

VSI 10"

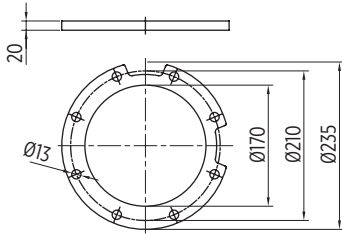

0050319 05/2023

VSI 12"

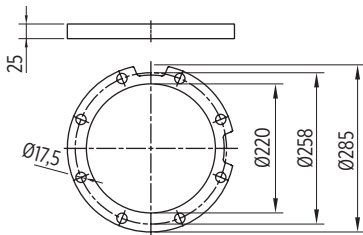

0050334 12/2023

CABLE GUARDS

VSI 8"

LOW (L)

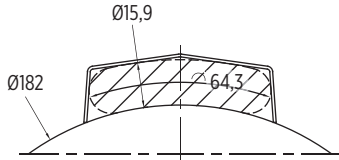

MEDIUM (M)

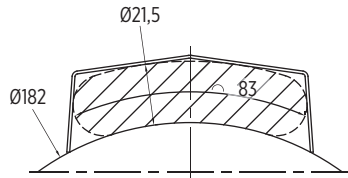

HIGH (H)

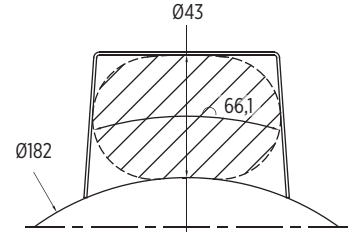

* Dimensions in [mm]

00130318 05/2023

VSI 10"

LOW (L)

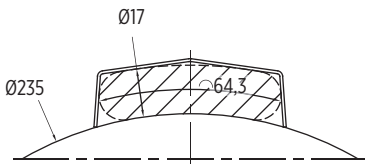

MEDIUM (M)

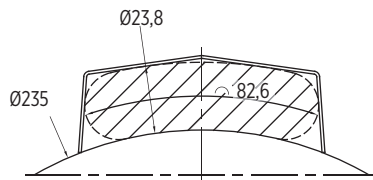

HIGH (H)

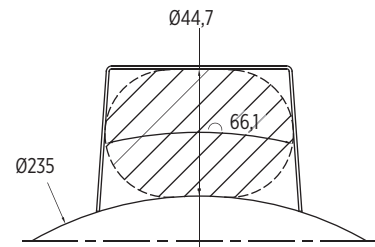

* Dimensions in [mm]

00130318 05/2023

VSI 12"

LOW (L)

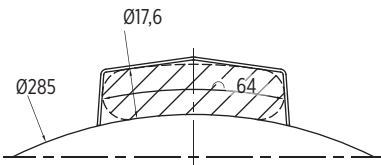

MEDIUM (M)

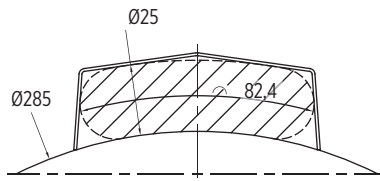

HIGH (H)

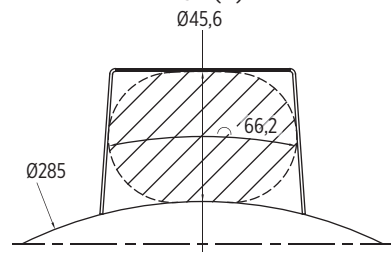

* Dimensions in [mm]

00130318 05/2023

MOTOR/PUMP CONNECTION SCREWS

MOTOR/PUMP CONNECTION SCREWS

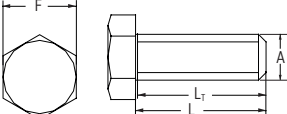
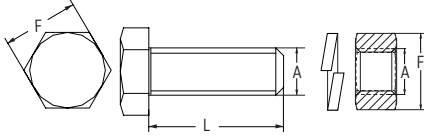
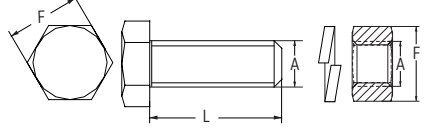
	Motor type	Material	L / LT [mm]	Thread type [mm]	F [mm]	Code
	6" CT	316SS	38.1	1/2-20UNF	19	308 659 318
	8" REW	316SS	70	M16	24	308 659 327
	10" REW 12" REW	316SS	80	M20	30	308 659 319

CATALOG REVISION CHANGES NOTICE

Rev. No.	Changes	Page
01	Added 12" in section Options	3
	Updated Family Curves	4
	Added 12" in General Features table	4
	Updated part number identification code	6
	Added 12" pump dimensional drawing	10
	Added 12" Hydraulic Performance data table VSI344	16, 17
	Added 12" dimensional data tables VSI344	45-47
	Added 12" Performance curves VSI344	48-51
	Added 12" motor brackets dimensional drawings	63
	Added 12" counterflanges dimensional drawings	64
	Added 12" cable guards dimensional drawings	65
02	Added 12" Hydraulic Technical data table VSI454	51-53
	Added 12" Performance curves VSI454	54-57



Franklin Electric

Franklin Electric Europa GmbH
Rudolf-Diesel-Str. 20 - 54516 Wittlich
GERMANY
Phone: +49 (0) 6571 - 105-0
Fax: +49 (0) 6571 - 105-510
Email: info@franklin-electric.de

Franklin Electric S.r.l.
Via Asolo, 7 - 36031 Dueville (Vicenza)
ITALY
Phone: +39 0444 361114
Fax: +39 0444 365247
Email: sales.it@fele.com



10000015689 EN REV.02_05-2024



franklinwater.eu

Single member - Company subject to the control and coordination of Franklin Electric Co., Inc.
Franklin Electric S.r.l. reserves the right to amend specification without prior notice.