

10" REWINDABLE MOTOR

Rewindable motors with best class winding wires



FEATURES & BENEFITS

- 10" double flange mounting design
- Factory filled with Franklin's FES93 motor fill solution
- High capacity Kingsbury type liquid lubricated 60 kN thrust bearing and radial bearings for 100 % maintenance free operation
- Pressure-equalizing diaphragm, spring pre-loaded
- Stainless Steel keyed shaft
- SandFighter™ sealing system with SIC mechanical seal and sand slinger is standard
- High efficiency electrical design for low operation costs
- Standard Motor: WW- Water well Design (Stator 304SS / Castings - CI Powder coated)
- Drinking water approvals

STANDARD SPECIFICATION

- Ratings: 85 - 185 kW
- Max. storage temperature - 15 °C to + 60 °C
- Standard motor with PPC winding insulation
- Nominal ambient temperature: 25 °C with 0.5 m/s cooling flow
- Standard Voltage: 380 - 415 V (50 Hz), 460 V (60 Hz)
- Voltage Tolerance: 50 Hz: 380-415 V - 10 % / + 6 % U_N [380 - 415 V = (380 - 10%) - (415 + 6 %)]; 60 Hz: 460V / ± 10 % U_N ,
- Protection IP68
- Motor protection: DIN 61947-4-1
- Frequency of starts: 10 starts/ hour (with min. 3 minutes resting time), equally distributed
- DOL / $Y\Delta$ - start (pos. of cables 90 °)
- Motor lead length: 6 m
- Installation orientation: Vertical / horizontal (shaft end heightened)
- Rotation counter clock wise facing shaft end (Rotation reversible)
- All motors with factory installed leads

OPTIONS

- Higher-graded materials: 316SS and 904L
- Special voltages
- Retrofittable PT 100 temperature sensor
- PE2/PA winding insulation for max. ambient temperature of 45 °C (Standard cooling flows)
- Special lead lengths on request

High Efficiency System Paket



- NEMA Synchron motors
- Frequency converter
- matchet output filter

▶ 10" High Efficiency System



10" Rewindable Motors - Model Numbers 50/60Hz *

P _N [kW]	U _N / f	Model Numbers Digit 1 – 6		Model Numbers Digit 7 – 10					
	[V] / [Hz]	DOL	YΔ	WW***	316 SS	904L	PE2/PA**		
							WW***	316 SS	904L
85	380 - 415 / 50 460 / 60	264 131	264 231	5111	6111	7111	5311	6311	7311
	380 / 60	264 661	264 761						
110	380 - 415 / 50 460 / 60	264 133	264 233	5111	6111	7111	5311	6311	7311
	380 / 60	264 663	264 763						
130	380 - 415 / 50 460 / 60	264 134	264 234	5111	6111	7111	5311	6311	7311
	380 / 60	264 664	264 764						
150	380 - 415 / 50 460 / 60	264 135	264 235	5111	6111	7111	5311	6311	7311
	380 / 60	264 665	264 765						
185	380 - 415 / 50 460 / 60	264 136	264 236	5111	6111	7111	5311	6311	7311
	380 / 60		264 766						

* VFD operation is only allowed up to 460V supply voltage, for higher voltages please consult Franklin Electric Europa GmbH

** For VFD Operation is PE2/PA mandatory!

*** WW motor - brackets Cast Iron Powder coated

10" Rewindable Motors - Performance Data 50Hz

P _N [kW]	Thrust F [N]	U _N [V]	n _N [min ⁻¹]	I _N [A]	I _A [A]	η (Eff.) [%] at % load			cos φ (PF) at % load			T _N [Nm]	T _A [Nm]
						50	75	100	50	75	100		
85	60 000	380	2890	179	783	85	86	85	0,78	0,85	0,87	281	282
		400	2900	174	828	83	85	85	0,72	0,81	0,85	280	316
		415	2910	171	863	83	85	85	0,68	0,78	0,83	279	342
		500	2890	136	595	84	85	84	0,78	0,84	0,87	281	282
		525	2900	133	631	83	85	85	0,72	0,81	0,85	280	316
		1000	2900	68	331	83	85	85	0,72	0,81	0,85	280	316
110	60 000	380	2910	235	1095	86	87	86	0,72	0,81	0,85	361	418
		400	2920	232	1158	84	86	86	0,65	0,76	0,82	360	467
		415	2920	233	1206	83	85	86	0,59	0,71	0,79	360	507
		500	2910	180	875	86	87	86	0,69	0,79	0,83	360	432
		525	2920	179	923	85	86	86	0,62	0,73	0,80	359	482
		1000	2920	89	463	84	86	86	0,65	0,76	0,82	360	467
130	60 000	380	2900	266	1271	88	88	87	0,79	0,85	0,87	428	487
		400	2920	256	1344	87	88	88	0,74	0,82	0,86	425	546
		415	2920	255	1400	87	88	87	0,69	0,78	0,83	425	592
		500	2900	202	966	87	88	87	0,79	0,85	0,87	428	487
		525	2920	195	1024	87	88	87	0,73	0,81	0,85	425	546
		1000	2910	104	523	87	88	87	0,76	0,83	0,86	426	516
150	60 000	380	2910	307	1502	87	87	86	0,79	0,85	0,88	492	568
		400	2920	298	1590	86	88	87	0,73	0,81	0,85	491	635
		415	2930	296	1655	86	87	87	0,67	0,77	0,83	489	689
		500	2910	233	1142	87	87	86	0,79	0,85	0,88	492	568
		525	2920	227	1211	86	87	87	0,73	0,81	0,85	491	635
		1000	2920	117	636	86	88	87	0,73	0,81	0,85	491	635
185	60 000	380	2900	390	2030	87	88	87	0,72	0,81	0,85	609	913
		400	2920	384	2148	86	88	88	0,64	0,75	0,81	605	1022
		415	2920	389	2237	84	86	86	0,57	0,70	0,79	605	1109
		500	2900	294	1500	87	88	87	0,72	0,81	0,85	610	888
		525	2910	289	1580	86	87	87	0,65	0,76	0,82	607	988
		1000	2900	148	859	87	88	87	0,72	0,81	0,85	609	913

10" Rewindable Motors - Performance Data 60Hz

P _N [kW]	P _{max} [kW]	Thrust F [N]	U _N [V]	n _N [min ⁻¹]	I _{max} [A]	I _A [A]	η _{max} (Eff.) [%] at % load			cos φ _{max} (PF) at % load			T _{max} [Nm]	T _A [Nm]
							50	75	100	50	75	100		
85	98	60 000	460	3500	172	803	83	85	85	0,76	0,83	0,86	267	281
			380	3510	216	1120	82	84	85	0,69	0,78	0,83	267	325
110	127	60 000	460	3510	225	1160	84	86	86	0,71	0,80	0,84	345	375
			380	3510	273	1430	84	86	86	0,70	0,79	0,84	346	382
130	149	60 000	460	3510	254	1308	86	87	87	0,77	0,84	0,87	408	437
			380	3510	309	1710	85	87	86	0,73	0,82	0,86	408	474
150	173	60 000	460	3510	294	1557	85	87	87	0,77	0,84	0,87	469	508
			380	3510	362	1980	85	87	87	0,75	0,83	0,86	468	535
185	213	60 000	460	3510	377	2130	85	87	87	0,70	0,79	0,84	585	858
			380	3510	448	2690	84	87	87	0,66	0,77	0,87	583	896

10" Rewindable De-Rating Curves

De-Rating of 10" Rewindable Motors with PPC Insulation

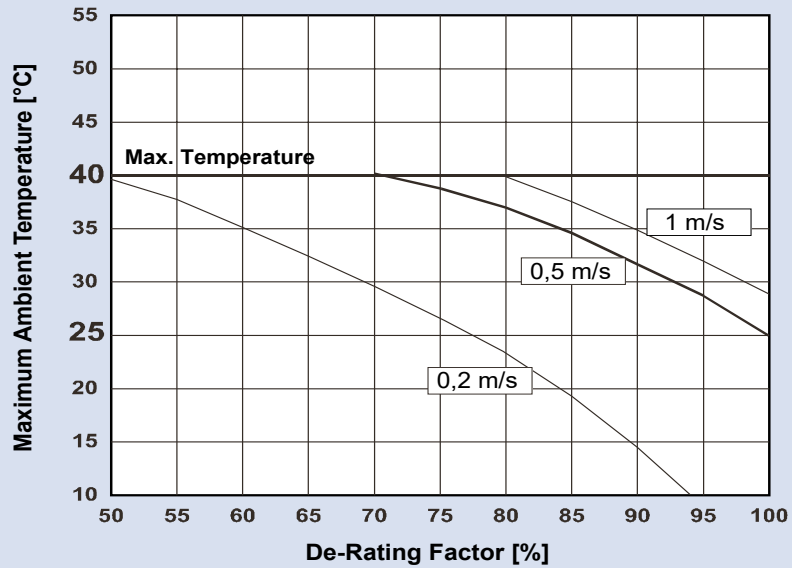

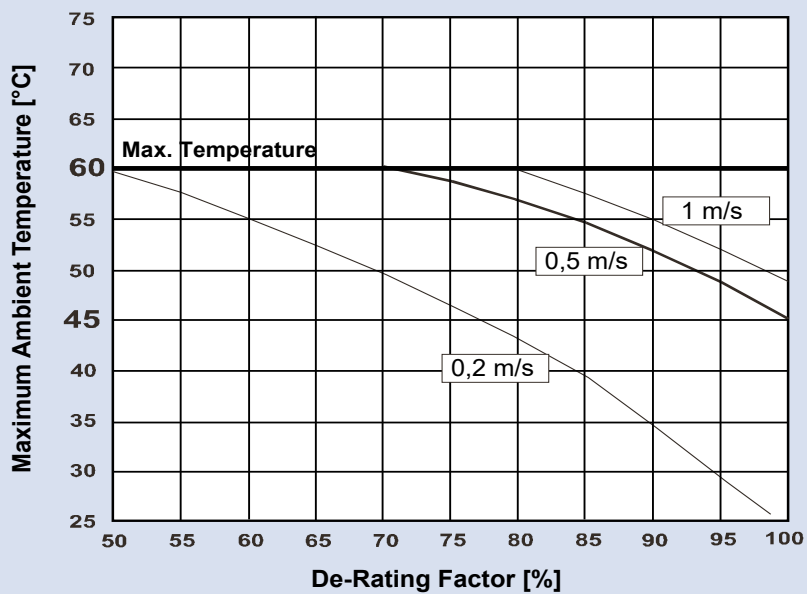

De-Rating of 10" Rewindable Motors with PE2/PA Insulation

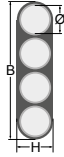
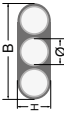

If these conditions are not met please contact Franklin Electric !

10" Rewindable Motors - Motor Leads

DOL									
Lead	P_N [kW]	\emptyset [mm ²]	B / H [mm]		Lengths [m]	Qty.	Lead Mod.- Nr.	Lead seal Kit WW / 316 Mod.- Nr.	Lead seal Kit 904L Mod.- Nr.
	85	4G25	B	44,3	6	1	308 710 116	308 660 720	308 660 724
			H	14,5					
	110 - 130	4G35	B	48,5	6	1	308 710 117	308 660 721	308 660 725
			H	16,5					
	130 - 150 (PE2/PA)	3X50	B	46,5	6	1	308 710 113	308 660 712	308 660 726
			H	19,5					
	185**	1X70	D	20,7	6	3	308 711 100 (Klt with 3 single leads 1x70)	308 660 732	308 660 733

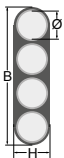
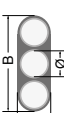
YΔ									
Lead	P_N [kW]	\emptyset [mm ²]	B / H [mm]		Lengths [m]	Qty.	Lead Mod.- Nr.	Lead seal Kit WW / 316 Mod.- Nr.	Lead seal Kit 904L Mod.- Nr.
 	85	3X16	B	28,8	6	1	308 710 118	308 660 722	308 660 727
			H	12,2					
		4G16	B	38,0		1			
			H	12,8					
	110 - 150	3X25	B	37,5	6	1	308 710 114	308 660 713	308 660 728
			H	16					
		4G25	B	44,3		1			
			H	14,5					
185	4G35	B	48,5	6	1	308 710 121	308 660 723	308 660 729	
		H	16,5						
	3X35	B	38,5		1				
		H	16,5						

For PE2/PA motors additionally the special Tape **700 541 688** is absolutely necessary

Ground lead* (optional)	\emptyset [mm ²]	D \emptyset [mm]	Lengths [m]	St.	Mod.-Nr.
	1G25	13,0	8	1	308 053 080
	1G35	15,3	6	1	308 056 060

*only for WW and 316SS

Lead opening seal kit	85 - 185 kW DOL / YΔ	WW / 316	308 660 715
		904L	308 660 730

Cables are designed for submerged operation. For air operation please consult Franklin Electric.

Electrical Connection

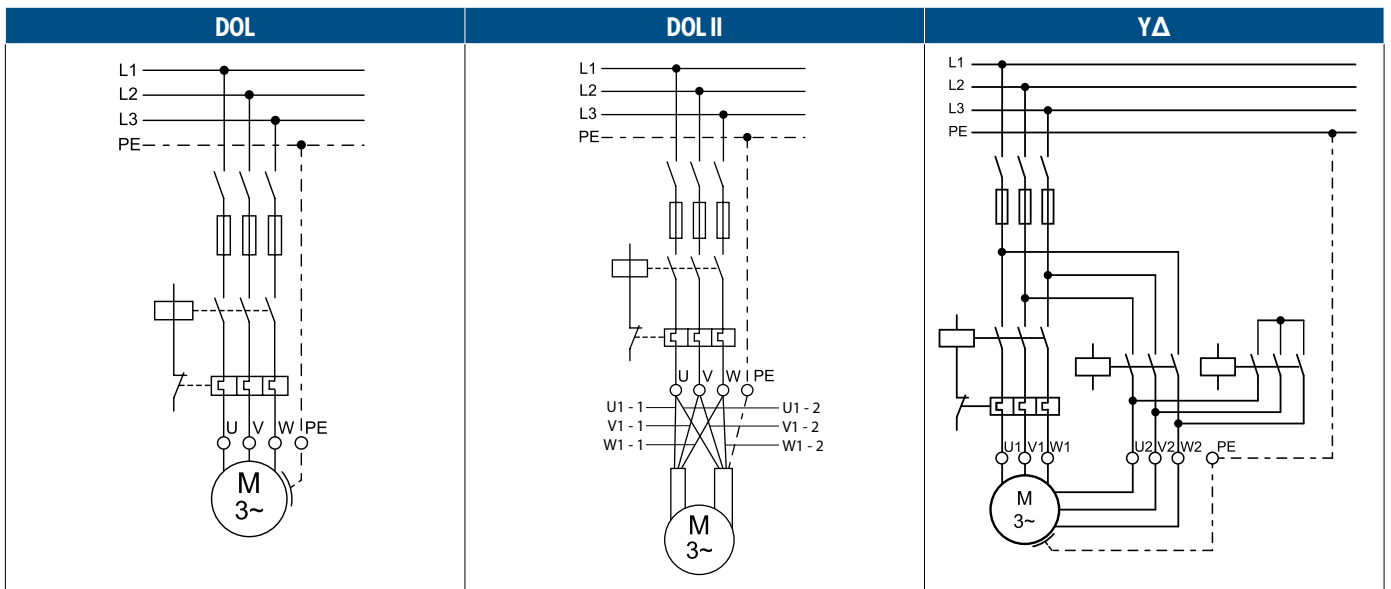

U	V	W	PE
brown	grey	black	yellow/green

10" Rewindable Spare Parts

Kit 1 Thrust Bearing Kit	WW/316SS/ 904L	Incl.Pos.: 17; 19; 20; 21; 32; 33	308 750 701
Kit 2 Radial Bearing Kit	WW/316SS/ 904L	Incl.Pos.: 15; 34	308 751 701
Kit 3 Seal Kit	WW/316SS	Incl.Pos.: 1 - 4; 11; 17; 25	308 800 703
	904L		308 800 704
Kit 4 Up-Thrust Kit	WW/316SS/ 904L	Incl.Pos.: 18	308 751 702
Kit 5 Screw Kit	WW/316SS	Incl.Pos.: 2.0; 5; 8; 13; 24; 37; 40	308 660 701
	904L		308 660 702
Kit 6 Lead Seal Kit	WW/316SS/ 904L	Incl.Pos.: 5; 6; 7	see page 167
Kit 7 PT100 Kit	WW/316SS/ 904L	Incl.Pos.: 9	see page 204
Kit 8 Valve Kit	WW	Incl.Pos.: 10; 11; 39	308 800 414

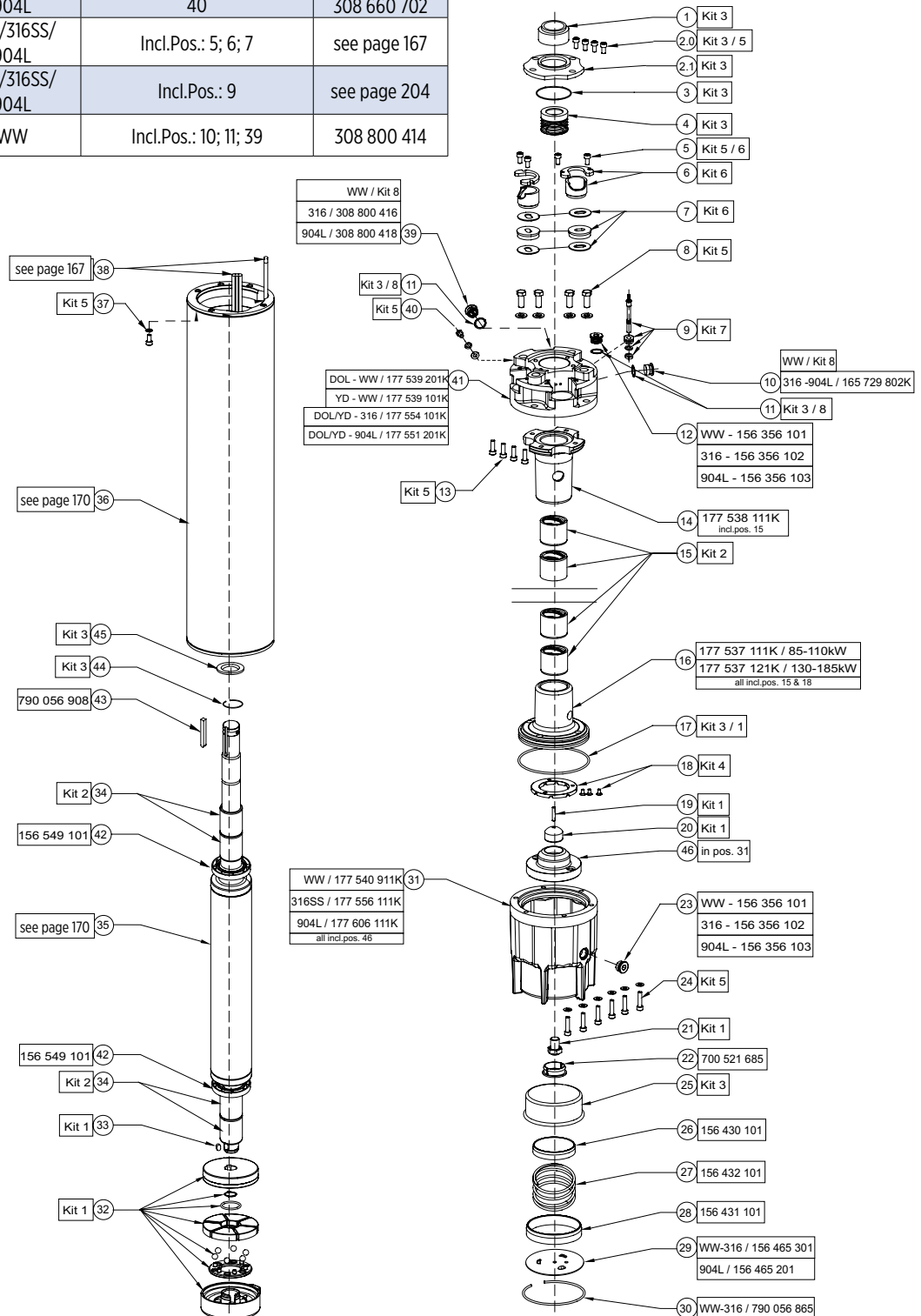

Stator and Rotor Model Number (50 / 60Hz)

P _N [kW]	U _N / f [V] / [Hz]	Stator (incl. Winding and 6 m motor lead)								Rotor
		WW/316		904L		WW/316		904L		
		DOL PPC	DOL PE2/PA	DOL PPC	DOL PE2/PA	YΔ PPC	YΔ PE2/PA	YΔ PPC	YΔ PE2/PA	
85	380 - 415/50 460/60	326 150 931	326 292 931	326 150 921	326 292 921	326 150 981	326 292 981	326 150 971	326 292 971	176 379 801K
110	380 - 415/50 460/60	326 158 931	326 302 931	326 158 921	326 302 921	326 158 981	326 302 981	326 158 971	326 302 971	176 379 802K
130	380 - 415/50 460/60	326 168 931	326 314 931	326 168 921	326 314 921	326 168 981	326 314 981	326 168 971	326 314 971	176 379 803K
150	380 - 415/50 460/60					326 177 981	326 325 981	326 177 971	326 325 971	176 379 804K
185	380 - 415/50 460/60		326 448 931			326 360 981	326 448 981	326 360 971	326 448 971	176 379 805K

PPC Insulation Standard Windings (380 – 415V/50Hz / 460V/60 Hz)

P _N [kW]	Mod.-No. Windingktis	Turns per coil	Wire diameter [mm]	Type of Isolation	Group connection	Total Wire length [m]	Resistance coil [Ω]	Resistance YΔ(U1-U2) [Ω]	Resistance Dol (U1-V1) [Ω]
85	326 150 999	11+11+11+11	2,5 / 3,6	PPC	Parallel	487,92	0,2825	0,141	0,094
110	326 158 999	8+9+8+9	2,8 / 4,0	PPC	Parallel	426,00	0,1955	0,1080	0,0680
130	326 168 999	7+8+7+8	2,2 / 3,1 2DR.II	PPC	Parallel	849,60	0,1579	0,0789	0,0570
150	326 177 999	6+7+6+7	2,3 / 3,3 2DR.II	PPC	Parallel	809,76	0,1374	0,0730	0,0458
185	326 360 999	5+5+6+5	2,5 / 3,6 2DR.II	PPC	Parallel	736,56	0,1050	0,0570	0,035

PE2/PA Insulation Standard Windings (380 – 415V/50Hz / 460V/60 Hz)

P _N [kW]	Mod.-No. Windingktis	Turns per coil	Wire diameter [mm]	Type of Isolation	Group connection	Total Wire length [m]	Resistance coil [Ω]	Resistance YΔ(U1-U2) [Ω]	Resistance Dol (U1-V1) [Ω]
85	326 292 999	11+11+11+11	2,3 / 3,5	PE2/PA	Parallel	488	0,3337	0,1668	0,1112
110	326 302 999	8+9+8+9	2,6 / 3,9	PE2/PA	Parallel	426	0,2267	0,1133	0,0755
130	326 314 999	7+8+7+8	2,0 / 3,1 2DR.II	PE2/PA	Parallel	850	0,1910	0,0955	0,0636
150	326 325 999	6+7+6+7	2,1 / 3,3 2DR.II	PE2/PA	Parallel	810	0,1647	0,0823	0,0549
185	326 448 999	5+5+6+5	2,3 / 3,5 2DR.II	PE2/PA	Parallel	735	0,1240	0,0620	0,0413

Insulation resistant (20°C / 500 VDC)

New motor without drop cable	400 > MΩ
Used motor without drop cable	20 > MΩ
New motor with drop cable	4 > MΩ
Used motor with drop cable	1 MΩ

10" REWINDABLE STANDARD MOTOR

10" REWINDABLE MOTORS DIMENSION AND MATERIALS

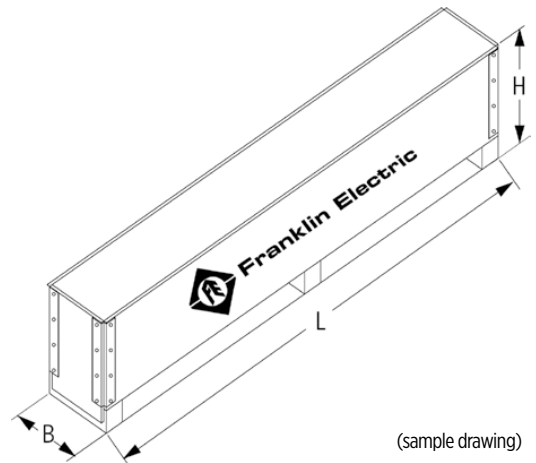
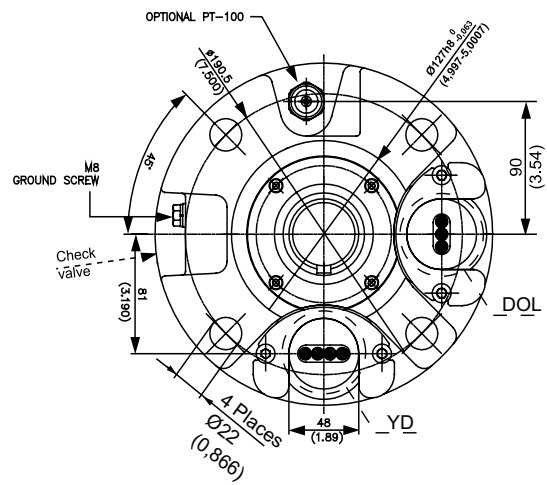
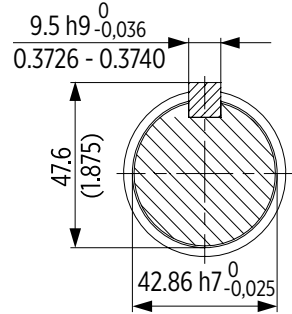
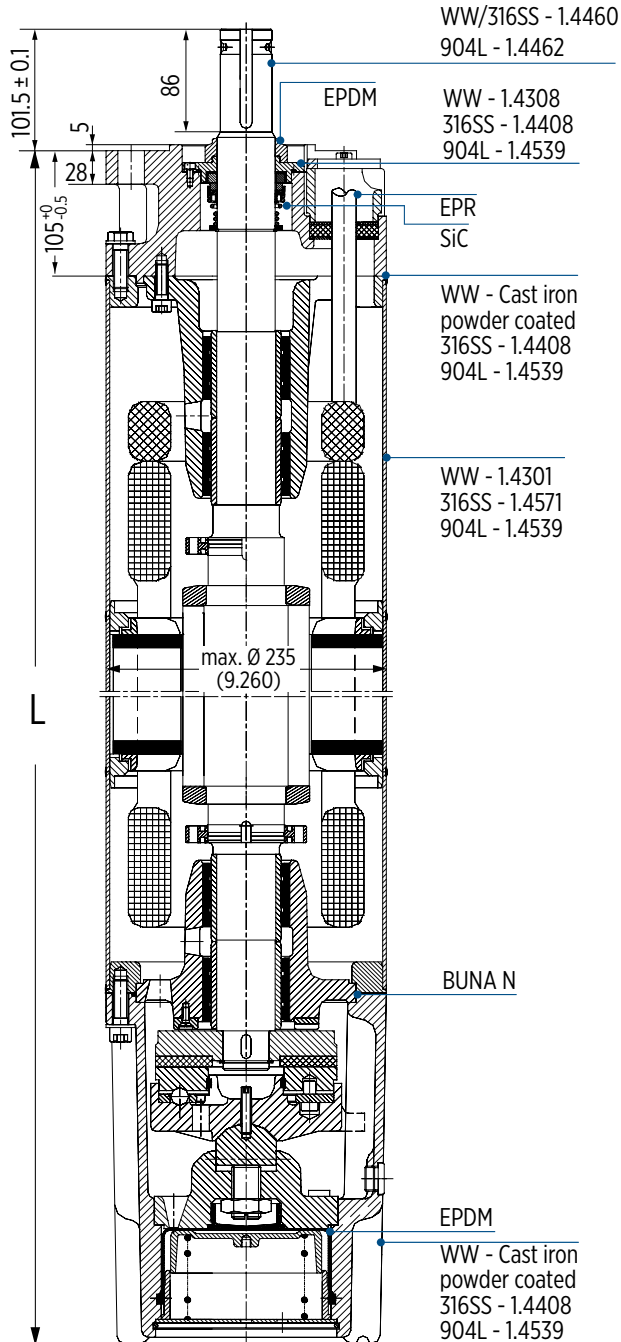

P_N [kW]	Motor lengths	Motor weights [kg]		Motor shipping size [mm]		
	L [mm]	Motor	Incl. Pack	B	H	L
85	1419	280	326	341	514	1896
110	1529	315	361			
130	1659	362	412	341	514	2246
150	1769	413	463			
185	1919	449	499			