

UPM3

1 x 230 V, 50/60 Hz



be
think
innovate

GRUNDFOS 

1. Pump versions	4	8. Technical description	34
2. Applications	5	Exploded view and sectional view	34
Gas- or oil-fired space and combination heaters	6	Material specification	34
Solid fuel heaters	6	Description of components	35
Heat pumps	6	9. Installation	45
Micro/Mini combined heat and power cogeneration	7	Pumped liquids	45
Thermal solar system	7	Ambient and liquid temperature	45
District heating systems with heat exchanger	7	Relative humidity	46
Space heating systems	7	Minimum inlet pressure	46
Combined space heating and cooling systems	7	Storing and transporting the product	46
Domestic hot water generation	7	Mechanical installation	47
Domestic hot water recirculation	7	Insulation	48
UPM3 - externally controlled variants	7	Preventing the pump from blocking	48
UPM3 - HYBRID variants	8	10. Electrical connection	49
Examples of systems	8	Supply voltage	49
3. Features and benefits	9	Earth leakage circuit breaker (ELCB)	49
Features	9	Inrush current	50
Benefits	9	Control box connections	52
UPM3 and UPM3 HYBRID variants	9	Overview of technical data	55
UPM3K	9	11. Performance curves and technical data	56
UPM3S	9	Curve conditions	56
UPM3L(K)	9	Measured pump head variants	56
UPMO	9	12. Accessories	57
UPM3F	9	Gaskets	58
Hydronic balancing	10	Insulation kits	58
ErP, Ecodesign regulation in brief	10	Quick guides, UPM3	58
4. Identification	11	Pins, clips, O-rings	58
Type key	11	ALPHA Reader	58
Nameplate options	13	13. Data sheets	59
5. Performance range	14	UPM3S XX-40 130/180 (N) (GFNHB)	59
6. External control mode and signals	16	UPM3S XX-50 130/180 (N) (GFNHB)	60
Control principles	16	UPM3S XX-60 130/180 (N) (GFNHB)	61
Control signals	16	UPM3S FLEX AS XX-60 130/180 (N) (GFNHB)	62
PWM interface	16	UPM3S AUTO XX-60 130/180 (N)	63
7. Control modes, operating panel and settings	20	UPM3(K) XX-50 130/180 (N) (GFNKB)	64
UPM3	20	UPM3(K) XX-60 130/180 (N) (GFNKB)	65
UPM3 HYBRID variants	20	UPM3(K) XX-70 130/180 (N) (GFNKB)	66
Control modes	21	UPM3(K) XX-75 130/180 (N) (GFNKB)	67
Overview of operating panel control modes	26	UPM3(K) FLEX AS XX-50 130/180 (N) (GFNKB)	68
Control modes with pump curves	28	UPM3(K) FLEX AS XX-70 130/180 (N) (GFNKB)	69
Control mode explanation	29	UPM3(K) FLEX AS XX-75 130/180 (N) (GFNKB)	70
Pump control in heating systems	30	UPM3(K) FLEX AS 15-75 CIL3 (GFNKB)	71
Advantages of pump control	30	UPM3(K) FLEX AS 15-75 GGES3 (GFNKB)	72
AUTO	30	UPM3(K) FLEX AS 15-75 GGMBP3 (GFNKB)	73
The	31	UPM3(K) FLEX AS 15-75 GGBP3 (GFNKB)	74
Selection of control mode	33	UPM3(K) FLEX AS 15-75 GGAOS3 (GFNKB)	75
		UPM3(K) FLEX AS 15-75 CIAO2 (GFNKB)	76
		UPM3(K) FLEX AS 15-75 CIAO2 AC (GFNKB)	77
		UPM3(K) FLEX AS 15-75 CES3 (GFNKB)	78

UPM3(K) FLEX AS 15-75 CACAO (GFNKB)	79
UPM3(K) FLEX AS 15-75 CESA01 (GFNKB)	80
UPM3(K) FLEX AS 15-75 CESA02 (GFNKB)	81
UPM3(K) FLEX AS 15-75 CESA04 (GFNKB)	82
UPM3(K) FLEX AS 15-75 AOKR (GFNKB)	83
UPM3(K) FLEX AS 15-75 CAOD (GFNKB)	84
UPM3(K) AUTO XX-50 130/180 (N) (GFNKB)	85
UPM3(K) AUTO XX-70 130/180 (N) (GFNKB)	86
UPM3(K) HYBRID XX-50 130/180 (N) (GFNKB)	87
UPM3(K) HYBRID XX-70 130/180 (N) (GFNKB)	88
UPM3(K) DHW XX-20 130/180 N (GFNKB)	89
UPM3(K) DHW XX-50 130/180 N (GFNKB)	90
UPM3(K) DHW XX-70 130/180 N (GFNKB)	91
UPM3(K) DHW 15-20 CIL3 PPS (GFNKB)	92
UPM3(K) DHW 15-50 CIL3 PPS (GFNKB)	93
UPM3(K) DHW 15-70 CIL3 PPS (GFNKB)	94
UPM3(K) SOLAR XX-75 130/180 (N) (GFNKB)	95
UPM3(K) SOLAR XX-105 130/180 (GFNKB)	96
UPM3(K) SOLAR XX-145 130/180 (GFNKB)	97
UPM3L XX-75 130/180 (N) (GFNKC)	98
UPM3L FLEX AS XX-75 130/180 (N) (GFNKC)	99
UPM3L AUTO XX-70 130/180 (N)	100
UPM3L HYBRID XX-70 130/180 (N)	101
UPMO XX-50 130/180, UPMO 60 PH (GFNKB)	102
UPMO XX-60 130/180, UPMO 60 PH (GFNKB)	103
UPMO XX-70 130/180, UPMO 60 PH (GFNKC)	104
14. Approvals and Certificates	105
VDE certificate	105
EurAsia conformity (EAC) certification	105
Drinking water approvals	105
Grundfos Product Chemical Compliance declaration concerning the non-use of certain chemical substances	105
REACH Regulation (EC 1907/2006)	106
Customer information regarding REACH, RoHS and other relevant chemical legislation and Grundfos' Product Chemical Compliance initiatives	106
WEEE Directive 2012/19/EU	106

1. Pump versions

UPM3S

Pump type	Type	External control	Internal control
UPM3S	XX-40/50/60	PWM A profile	-
UPM3S LIN	XX-60	LIN bus	-
UPM3S FLEX AS	XX-60	PWM A profile	CC/MAX
UPM3S AUTO	XX-60	-	PP/CP/CC/AA
UPM3S HYBRID	XX-60	PWM A/C profile	PP/CP/CC/AA

UPM3

Pump type	Type	External control	Internal control
UPM3(K) (N)	XX-50/60/70/75	PWM A profile for XX-50/60 PWM C profile for XX-70/75	-
UPM3(K) LIN (N)	XX-75	LIN bus	-
UPM3(K) FLEX AS (N)	XX-50/70/75	PWM A profile	CC/MAX
UPM3(K) AUTO (N)	XX-50/70	-	PP/CP/CC/AA
UPM3(K) SOLAR	XX-75/105/145	PWM C profile	CC
UPM3(K) DHW	XX-20/50/70	PWM A profile	MAX
UPM3(K) HYBRID (N)	XX-50/70	PWM A/C profile	PP/CP/CC/AA

UPM3L

Pump type	Type	External control	Internal control
UPM3L(K)	XX-75	PWM A profile	-
UPM3L(K) LIN	XX-75	LIN bus	-
UPM3L(K) FLEX AS	XX-75	PWM A profile	MAX
UPM3L(K) AUTO	XX-70	-	PP/CP/CC/AA
UPM3L(K) HYBRID	XX-70	PWM A/C profile	PP/CP/CC/AA

UPMO

Pump type	Type	External control	Internal control
UPMO	XX-50/60/70	PWM A profile	CC/MAX

Other versions or housings with different dimensions, materials, design or functionality are available on request. Please contact your Grundfos HVAC OEM KAM.

Abbreviations

PWM: Pulse-Width Modulation

PWM A/C: Externally controlled via PWM A or C profile

PP: Proportional pressure

CP: Constant pressure

CC: Constant curve

MAX: Maximum curve of PWM range

AA: AUTO_{ADAPT}

LIN: LIN bus (VDMA 24226)

N: Versions with stainless steel pump housings approved for drinking water

2. Applications

In a modern heating, cooling and domestic hot water supply system there are different circuits in which UPM3 pumps in different versions can be placed. A differentiation must be made between the heating (or cooling) production and the distribution.

On the production side there are some applications where pumps are used in primary or internal circuits, for example, for geothermal or solar thermal brine circuits.

The distribution side is often split into two circuits - a primary and a secondary circuit - in order to keep the flow and temperature independent from each other. A heat exchanger, a hydraulic separator or a buffer tank can be used for this separation.

For some heating generators, such as condensing boilers, heat pumps or district heating, it is important to keep the return temperature as low as possible. Therefore it is necessary to keep the right balance between flow in primary and secondary circuits. Without separator, the primary pump creates a differential pressure in the secondary circuits. A generator effect can happen in the secondary pump, from which UPM3 is protected.

The primary pump is mostly integrated into the heating appliance and controlled via a digital signal, for example, to ensure the optimum operation of the boiler, for instance.

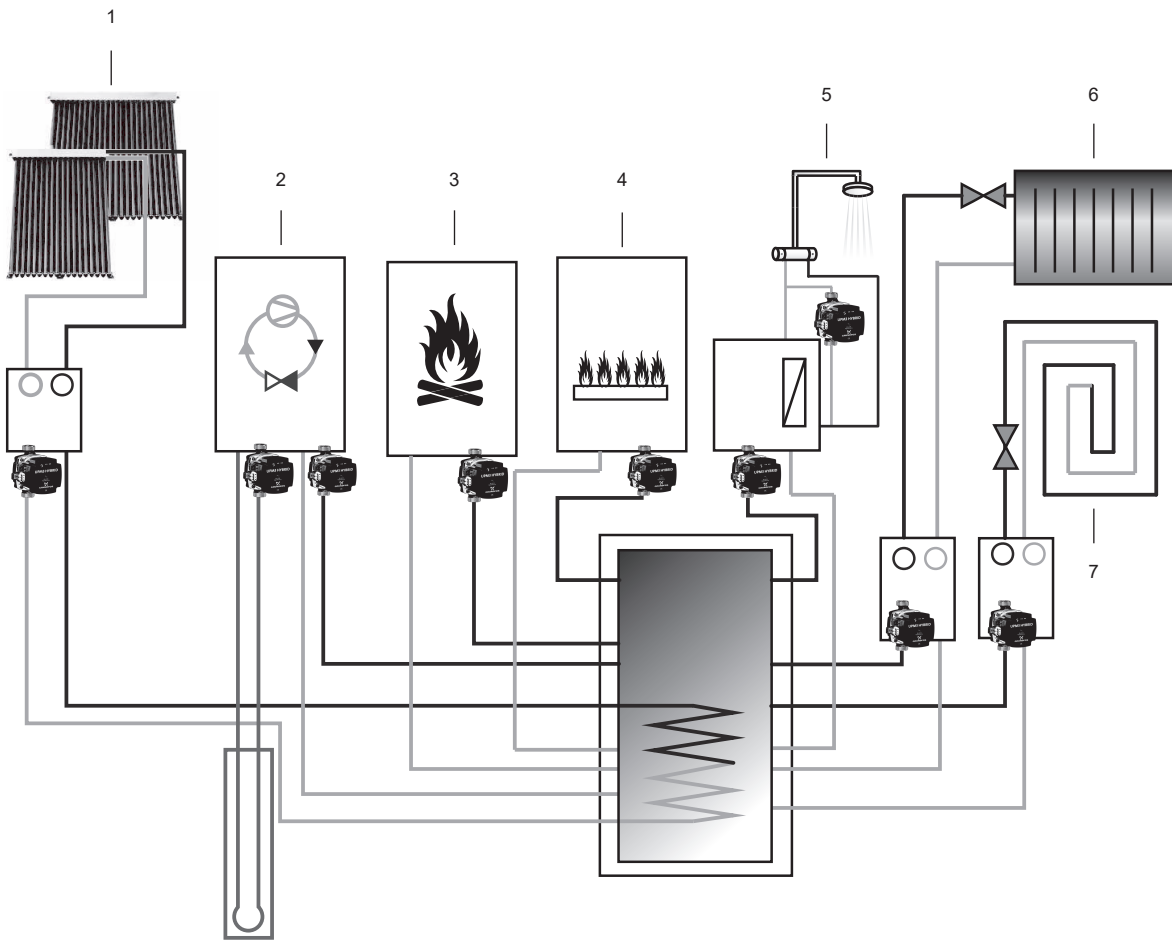

TM072331

Complete domestic heating system combined with renewable energy sources

Pos.	Description
1	Solar charging kit
2	Geothermal heat pump
3	Solid fuel boiler
4	Gas fuel boiler

Pos.	Description
5	Freshwater station
6	Heating kit
7	Underfloor heating kit

Recommended pump type according to application

	Application	Recommended type
Heat production or heat transmission side	Gas- or oil-fired space and combination heaters	UPM3, UPM3 LIN, UPM3 FLEX AS
	Solid fuel heaters	UPM3 FLEX AS, UPM3 AUTO
	Heat pumps (brine side)	UPM3(K), UPM3 LIN, UPM3(K) FLEX AS
	Heat pumps (heating side)	UPM3, UPM3 LIN, UPM3 FLEX AS
	Mini combined heat and power co-generation	UPM3, UPM3 LIN, UPM3 FLEX AS
	Thermal solar system (collector side)	UPM3(K) SOLAR
	District heating systems with heat exchanger	UPM3 FLEX AS, UPM3 AUTO
Heat distribution side	Space heating systems	UPM3 AUTO, UPM3 HYBRID
	Space heating and cooling systems	UPM3(K) AUTO, UPM3(K) HYBRID
	Domestic hot water generation (heating side)	UPM3 FLEX AS
	Domestic hot water generation (DHW side)	UPM3(K) DHW
	Domestic hot water recirculation	UPM3 DHW

Gas- or oil-fired space and combination heaters

Most of the installed systems for space and water heating in building services still use fossil fuels such as natural gas or mineral oil, although the use of gas and liquid fuels out of biomass is increasing. Heaters with higher water content, such as floor-standing boilers, are heated independent of the actual flow. Heaters, such as wall-mounted boilers, only operate when there is a minimum flow through the primary heat exchanger. In a combi-boiler, the pump supplies both the heating system and the hot water supply.

More and more of these heaters are condensing boilers temperature-controlled by a weather-compensating system controller with different time programs, which means the central heating water temperature is often lower than the domestic hot water temperature. In systems with domestic hot water supply either as combination heaters with integrated DHW supply or with external DHW tank or heat exchanger there is a need to increase the medium temperature temporarily above DHW temperature level. In small residential buildings, the heating demand for DHW is higher than for space heating. Internal (or external) pumps for these primary circuits must be controlled by the needs of the heaters to optimise the combustion conditions and the condensation process. Often this can only be guaranteed by using a variable-speed pump with external control signal from the boiler controller.

Solid fuel heaters

As most of these heaters use wood biomass such as pellets, split logs or wood chips, they can be seen as renewable energy and CO₂ neutral. These heaters are mostly reacting slowly on different heat demands. For this reason, the liquid temperature might increase and there is a need for keeping the flow constant and for storing the energy in a buffer tank.

Heat pumps

The following types of heat pumps are on the market:

- Compressor heat pumps with electric or combustion motors
- Sorption heat pumps. Sorption is a physical-chemical process where either a liquid or a gas is absorbed by another liquid (absorption) or is retained by the surface of a solid object (adsorption). Both processes are reversible and only occur under certain conditions through physical effects (pressure, temperature). Often a pump with customised specification is installed inside such a process unit.

Primary pumps depend on the heat transmission principle:

- Air-to-air heat pumps are often used in air-conditioning systems

No pump is used.

- Air-to-water heat pumps for space heating and cooling or water heating

The heat source is mainly outdoor air down to an outside temperature of -20 °C. Its energy is mainly extracted directly by a fan-supplied air evaporator of the heat pump. Sometimes there is a primary brine circuit between an outdoor air unit and a brine-to-water heat pump. This circuit is circulated by a pump that must stand liquid temperatures down to -20 °C.

- Water-to-water heat pumps for space heating and cooling or water heating

The energy source can be groundwater between 7 and 12 °C. Groundwater is extracted mainly via a submersible pump in a supply well and returned via a return well. If its water quality is not guaranteed, there is a primary circuit between a heat exchanger and the heat pump. This circuit is circulated by a pump that must stand liquid temperatures down to +2 °C.

- Brine-to-water heat pumps for space heating and cooling or water heating

Horizontal ground collectors or probes set vertically into the ground deliver the ground-stored solar energy via a mixture of water and antifreeze (brine) to the evaporator of the heat pump. This circuit is circulated by a pump that must stand liquid temperatures down to +2 °C or lower.

For smaller heat pumps with a minimum brine temperature of +2 °C, we recommend UPM3K with PWM signal input.

The secondary pumps do not differ much from boiler applications. The liquid temperature is normally not above 60 °C, the differential temperature is mostly small, e.g. ΔT 5K. Constant-speed compressor heat pumps often require constant flow and long cycle times. A buffer tank can prolong the cycle time and make the flow through the heat pump independent of the flow in the heating distribution circle. Variable-speed compressors often go together with a variable-speed pump, which should be externally controlled by the heat pump controller.

Micro/Mini combined heat and power cogeneration

Cogeneration of heat and power (CHP) can be divided into combustion engines, stirling engines and fuel cells. Dosing and pumps with customised specification are often installed inside the fuel cell process unit. Used secondary pumps are not that different from boiler applications. However, vibrations, liquid temperature and ambient temperature can be relatively high. Often a constant flow is required, therefore a buffer tank is an advantage.

Thermal solar system

Solar collectors convert sunlight into heat that can be used for heating or domestic hot water supply of buildings. The primary circuit is only in use if there is a positive temperature difference between the collector and the heat exchanger or tank. In pressurised thermal solar systems, pumps must stand glycol-based solar liquids with a high temperature range from +2 °C up to 110 °C with short peaks of up to 130 °C. Rarely, during startup of the system, the liquid temperature can cause condensation in the pump. For this reason, the UPM3 SOLAR has a drain hole, which must point downwards. The required flow and head can vary depending on the sizing of the system components. In a drain-back system the pump must be able to fill up the system each time it starts, which means that the head must be as high as the geodetic height of the system top.

UPM3 SOLAR is designed to be integrated in all kinds of thermal solar systems with either variable (matched-flow) or constant flow. High-efficiency ECM pumps such as UPM3 must not be speed-controlled by an external speed controller varying or pulsing the supply voltage. The speed can be controlled by a low-voltage PWM C signal from a solar controller in order to optimise the solar harvesting and the temperature of the system. Additionally, the power consumption of the pump will be reduced considerably. If no PWM signal is available, UPM3 SOLAR can be set to constant speed, only switched on and off by the controller.

District heating systems with heat exchanger

District heating systems supply all kinds of buildings with space heating and domestic hot water centrally or by flat stations. In systems with heat exchangers, the secondary pumps do not differ much from boiler applications, because system pressure and temperature values are equal.

Space heating systems

The secondary pump is often a self-controlled stand-alone pump, which can be mounted in a heating kit, and responds to the changing flow demand of heat consumers like radiators or underfloor heating circuits. Providing the best operating conditions for all components, hydraulic balancing is important for well-performing hydraulic systems. Especially in two-pipe heating systems with thermostatic valves, hydraulic balancing helps to avoid noises, oversupply, undersupply, too high pump performance, and saves energy. If an automatic bypass valve is installed to ensure a minimum flow, you must adjust the differential pressure control of the pump in a way to ensure the function of the automatic bypass valve. For example, select a constant pressure curve that is higher than the differential pressure of the valve. The maximum liquid temperature and differential temperature depends on the system design. T_{max} is normally from 30 to 90 °C, ΔT is between 5 and 20 K.

Combined space heating and cooling systems

Floor-heating or ceiling-cooling systems together with reversible heat pumps can heat rooms in winter and reduce the temperature of the room air by 4 to 6 degrees in summer with one system. When cooling the system, the liquid temperature must be kept above the dew point of the air to avoid condensing on the cooled floor, walls or ceilings. Condensation can occur in the pump occasionally. For this reason, it is recommended to use UPM3K pumps in such systems.

Domestic hot water generation

In indirect heated DHW systems, the pump can be placed on both sides of the heat exchanger. In a DHW cylinder, potable water is stored and usually heated indirectly by primary heating water from the boiler either by an external plate heat exchanger or by an internal indirect coil. Especially in renewable energy sourced systems, the primary heating water is stored and instant hot water is created by fresh water stations.

Domestic hot water recirculation

Hot water recirculation pumps circulate the potable water on the secondary side from the taps back to the water heater to ensure comfort and to avoid legionella. All pumps that come into contact with drinking water must be approved to be suitable for drinking water. UPM3 pumps with stainless-steel and PPS housings are made of materials which are suitable for drinking water use. The pumps are ACS (FR) and WRAS (UK) approved, and the materials in contact with drinking water comply to the applicable evaluation criteria issued by UBA (DE).

Related information

[Pump housing overview](#)

UPM3 - externally controlled variants

This pump range is designed for integration in boilers and other heating appliances with remote control of the speed, corresponding to UPM3 and UPM3 LIN variants.

UPM3 - HYBRID variants

This pump range with operating panel is designed for several purposes:

- The internal-controlled variant can be used in heating appliances as stand-alone or replacement pump, for example in heating kits.
- The remote-controlled variant can be integrated in boilers and other heating appliances where the speed is changed, corresponding to low-voltage PWM signal input.
- A combination of both.

The internal-controlled variants are suitable for the following systems:

- systems with constant or slightly variable flows such as one-pipe heating systems
- systems with variable flows such as two-pipe heating systems with thermostatic valves for radiators or underfloor heating.

Examples of systems

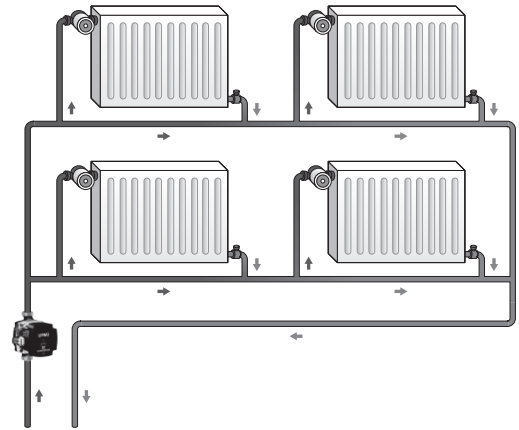

TM060528

One-pipe heating system

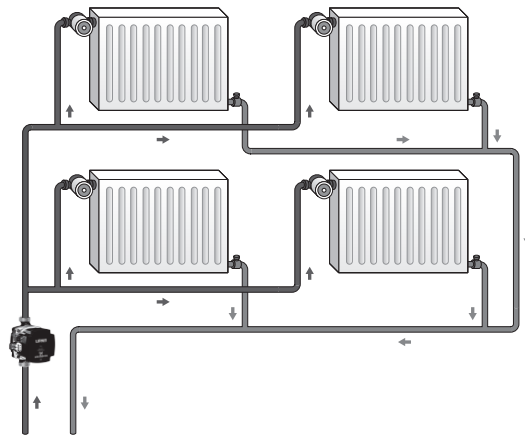

TM060526

Two-pipe heating system

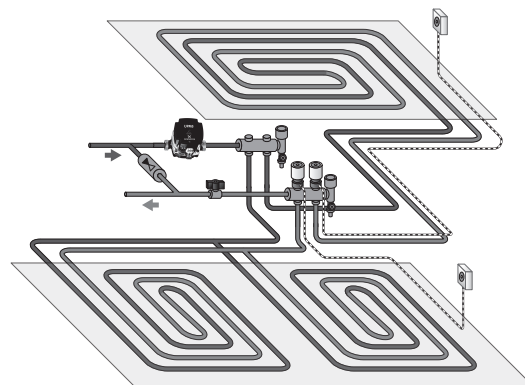

TM060527

Underfloor heating system

3. Features and benefits

Features

- Speed-controlled, high-efficiency pump fitted with electronically commutated motor (ECM) with permanent-magnet rotor and frequency converter.
- Either externally controlled by digital pulse-width modulation (PWM) low-voltage signal, LIN bus signal or internally controlled in constant pressure, proportional pressure or constant speed mode defined by a smart operating panel or factory presetting.
- Smart Hydro Block (SHB): An integrated diverter valve making the pump able to switch between central heating and domestic hot water circuits. The SHB is controlled by the pump.
- Hydronic balancing with Grundfos GO Balance.
- Third generation of the first boiler-integrated, variable-speed ECM pumps which combines both validated and newly developed components and concepts.
- Highly reliable as more than 20,000,000 UPM units have been installed with success since 2006.
- Fits into existing boiler ranges.
- Cost-optimised and reliably available due to established mass production facilities.
- Energy-optimised due to improved hydraulic and motor efficiency.

Benefits

- Uses up to 87% less electrical power than conventional constant-speed pumps.
- Uses up to 68% less electrical power than conventional speed-controlled pumps.
- Uses up to 25% less electrical power than the first generation of ECM pumps.

UPM3 and UPM3 HYBRID variants

- UPM3 is the first Grundfos high-efficiency pump with the terminal box in front and access to a mechanical deblocking device.
- UPM3 is the first Grundfos high-efficiency pump for high ambient and media temperature of up to 70 °C / 110 °C.
- UPM3 is the first Grundfos high-efficiency, PWM controlled pump with an EEI below benchmark level of $EEI \leq 0.20$.
- UPM3 is the first Grundfos OEM pump with TE Superseal connectors for power and signal supply.
- UPM3 AUTO is the first Grundfos self-controlled pump with constant pressure AUTO_{ADAPT} mode, which can be used in underfloor heating systems.
- UPM3 HYBRID is the first hybrid version of externally and internally controlled, high-efficiency Grundfos pumps.
- UPM3 LIN is the first Grundfos LIN bus pump for appliance-integrated communication.

UPM3K

- The UPM3K pump range is designed for condensing applications with media below ambient temperature.
- The stator housing is CED electrocoated with one drain hole in two possible positions, as IPX4D.
- The minimum admissible media temperature can be down to -10 °C.

UPM3S

- The UPM3S pump range is designed for integration in boilers and other heating appliances with limited performance up to 6 m / 42 W.
- The rotor is injection-moulded with PPS bonded hard ferrite magnetic particles.

UPM3L(K)

- The UPM3L pump range is designed for integration in boilers and other heating appliances with extended performance up to 7.5 m / 75 W.
- The ambient temperature is limited to 55 °C.
- The media temperature is limited to 95 °C (TF95).

UPMO

- UPMO pumps are designed for replacement in systems that use old hydraulic interfaces with UP/ UPO, UPS/UPSO, UPR/UPRO, UPER/UPERO pump heads.
- The UPMO pump head fits most of the existing small UP15 housings that are used in Integrated Water Circuits (IWC) or hydro blocks, as well as customised or standard housings made of composite, cast iron, bronze or stainless steel.
- UPMO can be used as ErP conform replacement for asynchronous integrated or stand-alone pumps in existing heating systems.
- UPMO can be used with internal control mode constant pressure.
- UPMO is also equipped with PWM interface using PWM profile A.
- The performance of UPMO pumps might be different from the performance of the pumps that should be replaced. The power consumption is significantly lower, the PWM signal is not compatible. Grundfos HVAC OEM together with the OEM customer have to check in a validation process, if successful replacement is possible.
- UPMO is fulfilling all CE requirements, such as LVD, EMC & ErP. Space and temperature features suit most OEM requirements. Therefore it can be used in most heating appliances without constraints.

UPM3F

- This pump is designed to work in environments where propane (A3 flammable refrigerant) is present.

Hydronic balancing

Hydronic balancing is important for a well-performing heating system with respect to energy consumption and room comfort. A balanced system secures the best possible distribution of the needed flow in the heating system. It also secures that the pump performance is not too high.

When using a UPM LIN pump together with the Grundfos GO Balance app and the ALPHA Reader dongle, it is possible to perform hydronic balancing of two-pipe or underfloor-heating systems by using real-time flow measurement from the pump.



TM068574

ALPHA Reader

ErP, Ecodesign regulation in brief

The EU has addressed the climate challenge in a EuP/ErP directive: of August 2015, all stand-alone pumps, as well as pumps integrated in boiler systems, solar systems and heat pump systems must fulfill Ecodesign requirements on glandless pumps, defined in regulation 641/2009/EC amended by 622/2012/EC. The regulation has set radically new standards for energy efficiency.

The essentials

- Glandless pumps integrated in products must have an energy efficiency index (EEI) of not more than 0.23. The benchmark level is 0.20.
- Stand-alone pumps are measured according to EN 16297-2.
- Integrated pumps are measured according to EN 16297-3, due to their various functions integrated in many customised hydraulic solutions on the market.
- All pumps integrated in products which generate and/or transfer heat and all types of media are included. This means that not only heating systems, but also solar thermal and heat pump systems are affected by the Ecodesign regulation.
- Non-compliant spare pumps for integrated pumps sold before August 2015 are allowed until January 1st, 2020.
- Pumps designed for recirculation of drinking water are out of scope of this regulation.
- Conformity with EU regulations are governed through mandatory CE marking.

All UPM3(K), UPM3S, UPM3L, UPMO variants meet the Ecodesign requirements measured by EN 16297-2 and EN 16297-3:2012.

4. Identification

Type key

Example: UPM3 SOLAR 15 - 145 130 C A X 9 XXX

Code	Explanation	Designation
UPM3	Standard	Pump type
UPM3S	Small version with IMM rotor	
UPM3L	Large version with extended P1	
UPMO	For ErP upgrade and replacement	

Code	Explanation	Designation
F	For flammable refrigerant environments	Control variant
K	Cold water	
FLEX AS	PWM A, MAX	
SOLAR	PWM C, CC	
DHW	PWM A, MAX	
AUTO	PP, CP, CC, AA	
HYBRID	PWM A/C, PP, CP, CC, AA	
LIN	LIN bus	

Code	Explanation	Designation
15	R 1/2" / G 1"	Nominal diameter
25	R 1" / G 1 1/2"	
32	R 1 1/4" / G 2"	

Code	Explanation	Designation
20	2 m	Maximum head
40	4 m	
50	5 m	
60	6 m	
70	7 m	
75	7.5 m	
105	10.5 m	
145	14.5 m	

Code	Explanation	Designation
130	Cast iron CED, 130 mm	
180	Cast iron CED, 180 mm	
N 130	Stainless steel, 130 mm	
N 150	Stainless steel, 150 mm	
N 180	Stainless steel, 180 mm	
GGES2	Cast iron CED, end suction UPM3	
GGAOS3	Cast iron CED, AOS3 UPM3	
GGMBP3	Cast iron CED, GGMBP3 UPM3	
GGBP3	Cast iron CED, GGBP3 UPM3	
CIL3PA	Composite CIL3, PA6.6 UPM3	Pump housing
CIL3PP	Composite CIL3, PPS UPM3	
CIAO2A	Composite CIAO2 AC	
CIAO2	Composite CIAO2	
CESAO1	Composite CESAO1	
CESAO2	Composite CESAO2	
CESAO4	Composite CESAO4	
CACAO	Composite CACAO	
AOKR	Composite AOKR	
CAOD3	Composite CAOD3 UPM3	

Code	Explanation	Designation
A	PWM A profile, heating	
C	PWM C profile, solar	
N	LIN bus	External control signals 1 and 2
Z	No profile	

Code	Explanation	Designation
A	0-563 rpm	Minimum speed
J	> 2.025 rpm	

Code	Explanation	Designation
X	TE MSS NdFeB Relay	
Y	FCI NdFeB Relay	
V	TE MSS NdFeB NTC	Control signal connector
W	FCI NdFeB NTC	
T	TE MSS IMM NTC	
U	FCI IMM NTC	

Code	Explanation	Designation
3	3 h (right)	
6	6 h (below)	
9	9 h (left)	Control box orientation
0	12 h (top)	

Code	Explanation	Designation
	XXX	Customer code

Nameplate options

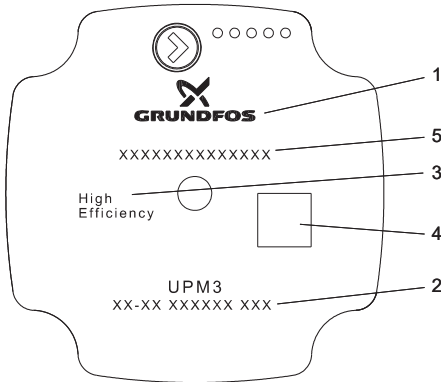

Nameplate: Grundfos standard

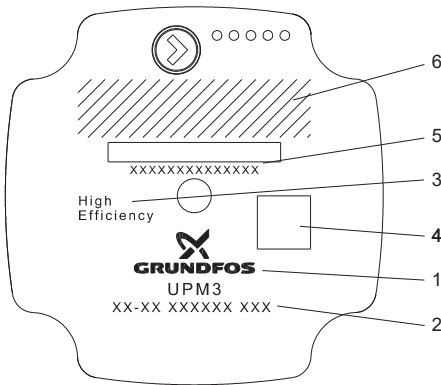

Nameplate: customised layout

Pos.	Description
1	Grundfos logo
2	Grundfos pump type
3	High efficiency indicating ECM technology
4	Grundfos data matrix
5	Customer product number or barcode
7	Area for customer specific logo

Terminal box side

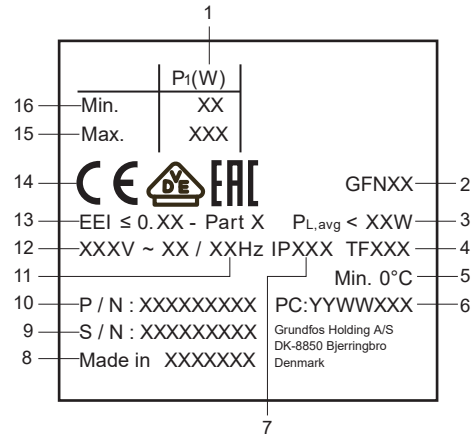

Terminal box side

Pos.	Terminal box side
1	Input power at minimum and maximum performance
2	Product mark (legal product code)
3	Average power input $P_{L,avg}$ (Ecodesign regulation)
4	Temperature class
5	Minimum liquid temperature (only cold water pumps)
6	Production code (year and week) and customer ID
7	Enclosure class
8	Production site
9	Serial number
10	Product number
11	Frequency [Hz]
12	Voltage [V]
13	Energy index with indication of measurement standard
14	CE mark and approvals
15	Maximum
16	Minimum

5. Performance range

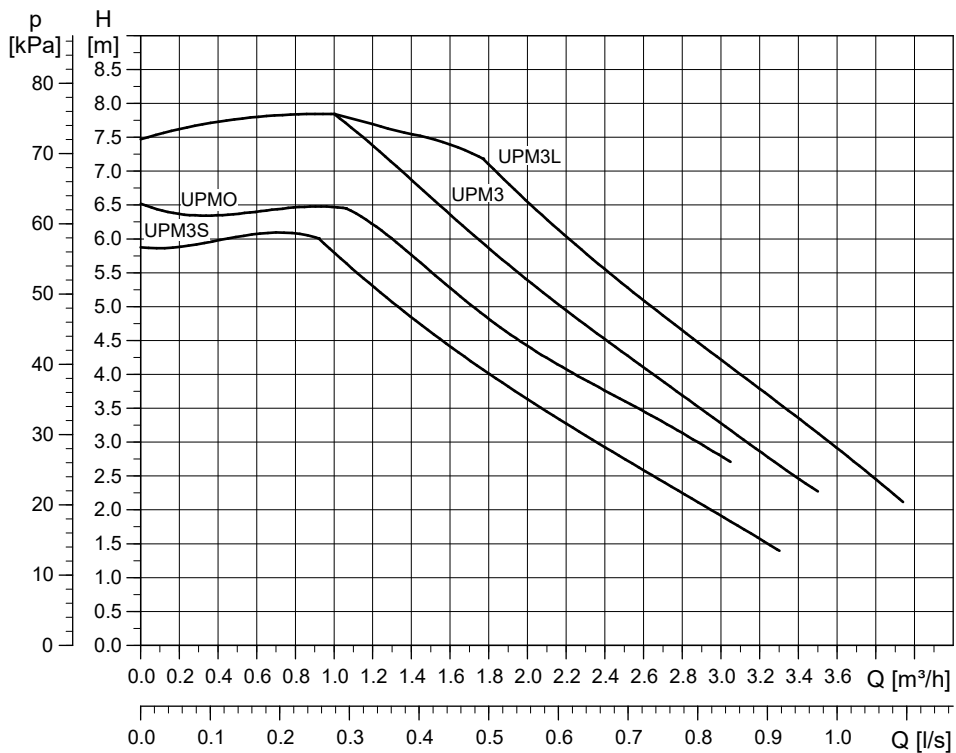

TM072400

Performance range UPM3, UPM3L, UPM3S, UPMO

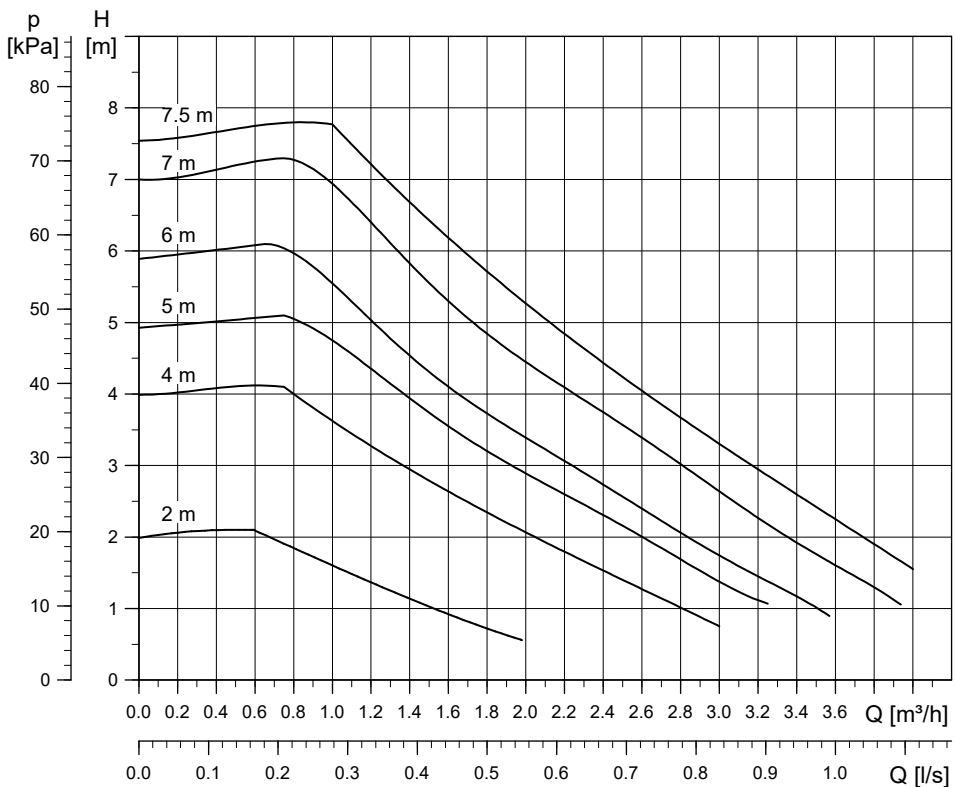

TM068462

Performance range UPM3, cast iron pump housing

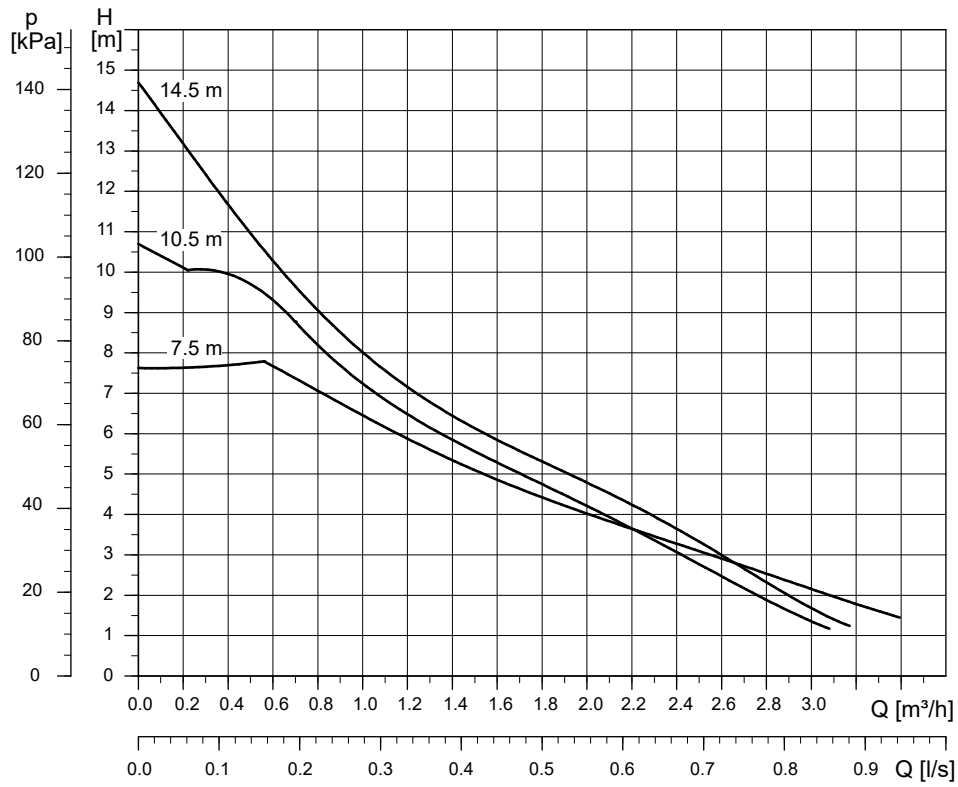

TM068463

Performance range UPM3 SOLAR, cast iron pump housing

6. External control mode and signals

Control principles

The UPM3 and UPM3 FLEX pumps are controlled via a digital low-voltage pulse-width modulation (PWM) signal, which means that the speed of rotation depends on the input signal.

UPM3 HYBRID pumps can be set to be controlled either internally or externally. The speed changes as a function of the input profile. These communication signals are standardised in the VDMA Einheitsblatt 24244 "Wet runner circulating pumps - Specification of PWM control signals".

Control signals

Digital low-voltage PWM signal

The square-wave PWM signal is designed for a 100 to 1500 Hz frequency range. The PWM signal is used for selecting the speed (speed command) and as feedback signal. The PWM frequency on the feedback signal is fixed at 75 Hz in the pump.

Duty cycle

$$d \% = 100 \times t/T$$

Example	Rating
T = 2 ms (500 Hz)	$U_{IH} = 4-24 \text{ V}$
t = 0.6 ms	$U_{IL} \leq 1 \text{ V}$
d % = $100 \times 0.6 / 2 = 30 \%$	$4.5 \text{ mA} \leq I_H \leq 10 \text{ mA}$ (depending on U_{IH})

Example

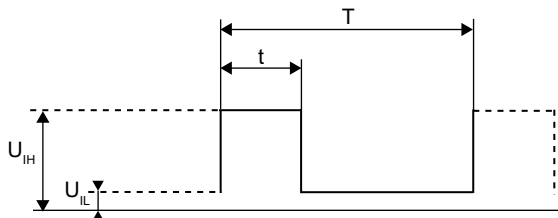

TM049911

PWM signal

Abbreviation	Description
T	Period of time [sec.]
d	Duty cycle [t/T]
U_{IH}	High-level input voltage
U_{IL}	Low-level input voltage
I_{IH}	High-level input current

PWM interface

The PWM interface consists of an electronic part connecting the external control signal to the pump. The interface translates the external signal into a signal type that the microprocessor can understand.

In addition, the interface ensures that the user cannot get into contact with dangerous voltage if touching the signal wires when power is connected to the pump.

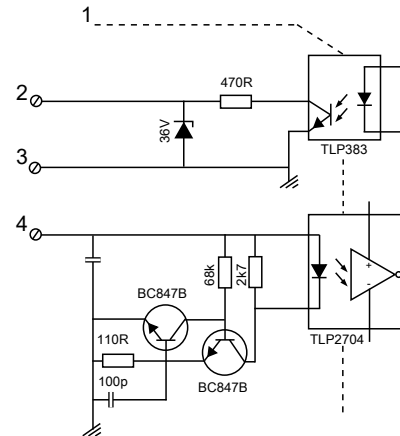

TM060787

Schematic drawing, interface

Pos.	Description
1	Galvanic isolation
2	PWM output
3	Signal reference (without connection to protective earth)
4	PWM input

Related information

[UPM3](#)

PWM input signal profile A (heating)

At high PWM signal percentages (duty cycles), a hysteresis prevents the pump from starting and stopping if the input signal fluctuates around the shifting point. At low PWM signal percentages, the pump speed is high for safety reasons. In case a cable breaks in a gas boiler system, the pumps will continue to run at maximum speed to transfer heat from the primary heat exchanger. This is also suitable for heat pumps to ensure that the pumps transfer heat even if a cable breaks.

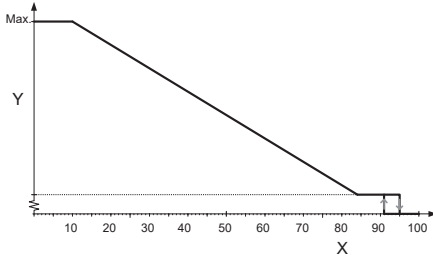

TM049985

PWM input profile A (heating)

Axis	Value
X	PWM input signal [%]
Y	Speed

PWM input signal [%]	Pump status
≤ 10	Maximum speed
$> 10 / \leq 84$	Variable speed from minimum to maximum speed
$> 84 / \leq 91$	Minimum speed
$> 91 / 95$	Hysteresis area: on/off
$> 95 / \leq 100$	Standby mode: off

PWM input signal profile C (solar)

At low PWM signal percentages (duty cycles), a hysteresis prevents the pump from starting and stopping if the input signal fluctuates around the shifting point. Without PWM signal percentages, the pump stops for safety reasons. If a signal is missing, for example if a cable breaks, the pump stops to avoid overheating of the solar thermal system.

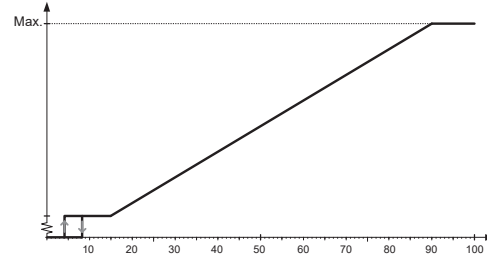

TM051575

PWM input profile C (solar)

Axis	Value
X	PWM input signal [%]
Y	Speed

PWM input signal [%]	Pump status
≤ 5	Standby mode: off
$> 5 / \leq 8$	Hysteresis area: on/off
$> 8 / \leq 15$	Minimum speed
$> 15 / \leq 90$	Variable speed from minimum to maximum speed
$> 90 / \leq 100$	Maximum speed

PWM feedback signal (standard)

The PWM feedback signal offers the same pump information as in bus systems:

- current power consumption (accuracy $\pm 2\%$ of PWM signal)
- warning
- alarm
- operating status.

Alarms

Alarm output signals are available because some PWM output signals are dedicated to alarm information. If a supply voltage is measured below the specified supply voltage range, the output signal is set to 75 %. If the rotor is locked due to deposits in the hydraulics, the output signal is set to 90 % as this alarm has a higher priority.

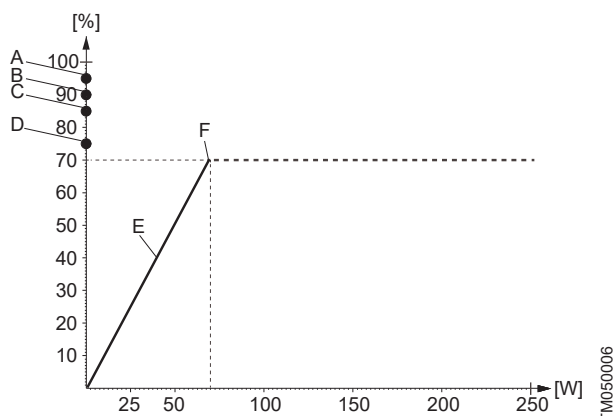

PWM feedback signal, UPM3 power consumption

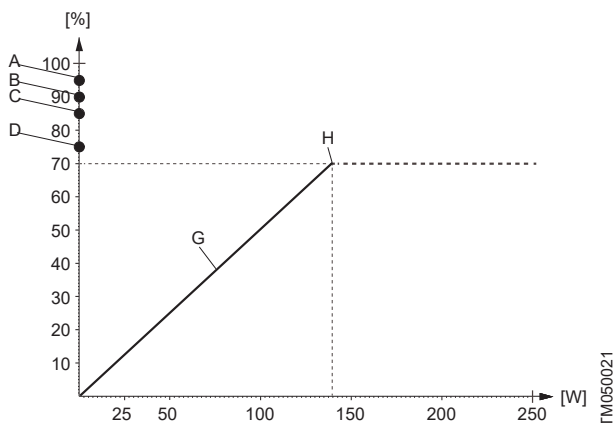

PWM feedback signal, UPM3L power consumption

Pos.	Description
X-axis	Output power consumption [W]
Y-axis	PWM output signal in percentage [%]
A	Standby (stop)
B	Alarm stop: fault, blocked pump
C	Alarm stop: electrical fault
D	Warning

Pos.	Description
E	Slope: 1 % / watt PWM signal
F	Saturation at 70 W
G	Slope: 2 % / watt PWM signal
H	Saturation at 140 W

PWM output signal [%]	QT [s]	Pump info	DT [s]	Priority
95	0	Standby (stop) by PWM signal	0	1
90	30	Alarm, stop, blocked error	12	2
85	0-30	Alarm, stop, electrical error	1-12	3
75	0	Warning	0	5
0-70	0-70 W (slope 1 W/% PWM)			6

Output frequency: 75 Hz $\pm 5\%$

QT = qualification time, DT = disqualification time

PWM feedback signal - flow estimation (on request)

On request, the PWM feedback signal can also be used to indicate the flow of the pump on defined pump housings, for example cast iron inline, above a head of 1 m. The accuracy of the feedback signal depends on the media, media temperature and operation point, but it gives information on the actual flow (see figure below).

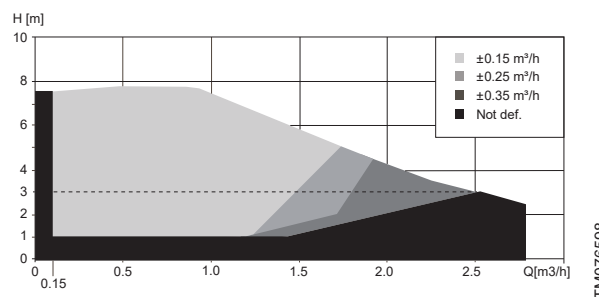

In the following example, the PWM output range between 0-70 % shows the flow between 0 and 2.1 m³/h with a slope of 0.03 m³/h / % PWM (see figure below).

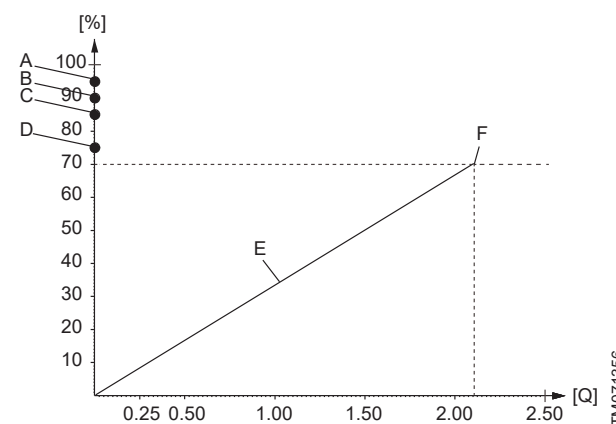

PWM feedback signal - flow estimation

Pos.	Description
A	Standby (stop)
B	Alarm stop: fault, blocked pump
C	Alarm stop: electrical fault
D	Warning
E	Slope: 0.03 [m ³ /h]/% PWM
F	Saturation at 2.1 [m ³ /h]

Control signal data levels

Maximum rating	Symbol	Value
PWM frequency input with high-speed optocoupler	f	100-4000 Hz*
Rated input voltage - high level	U _{IH}	4-24 V
Rated input voltage - low level	U _{IL}	< 1 V
High-level input current	I _{IH}	< 10 mA
Input duty cycle	PWM	0-100 %
PWM frequency output, open collector	f	75 Hz ± 5 %
Accuracy of output signal regarding power consumption	-	± 2 % (of PWM signal)
Output duty cycle	PWM	0-100 %
Collector emitter breakdown voltage on output transistor	U _c	< 70 V
Collector current on output transistor	I _c	< 50 mA
Maximum power dissipation on output resistor	P _R	125 mW
Zener diode working voltage	U _z	36 V
Maximum power dissipation in Zener diode	P _z	300 mW

* Only for standard profiles.

LIN bus

The LIN variant is ready for the Local Interconnect Network (LIN) bus communication protocol that is standardised in the "VDMA Einheitsblatt 24226". This data bus has been developed as LIN in the automotive sector and enables great interchange of data between the pump and the HVAC application.

New unique features, such as hydronic balancing of heating systems via the Grundfos GO Balance app, can be set using LIN bus communication.

In order to provide you the best support, Grundfos has divided the LIN bus data points into four specific modules:

- Grundfos LIN-Bus (basic)
- Performance module
- Optimization module
- Data analytics.

Contact your local Grundfos HVAC OEM representative to learn more about LIN bus.

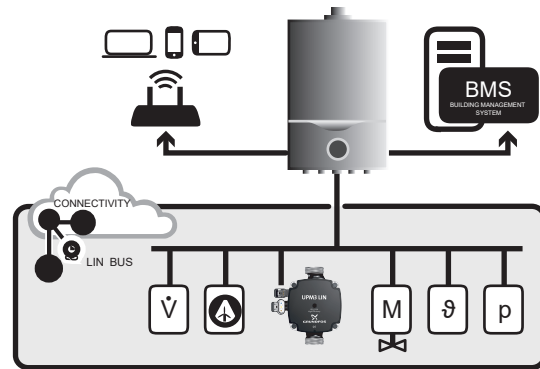

TM068459

LIN bus on fieldbus of heating control systems

7. Control modes, operating panel and settings

UPM3

UPM3 is externally controlled via a PWM or LIN bus signal.

Related information

[PWM interface](#)

Operating panel

The operating panel is designed with one red/green LED.

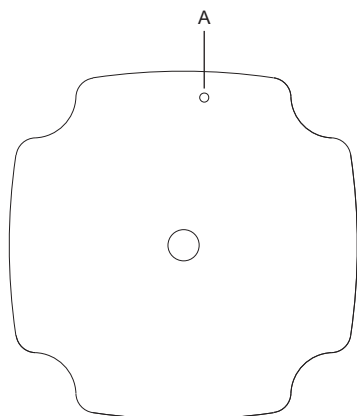

TM075425

UPM3 operating panel

Pos.	Description
A	LED

The LED shows whether the pump is controlled externally or if the pump experiences an error.

	Green LED	Red LED
No external control	•	
External control	• ¹	
Alarm		•

¹ 12 flashes per second.

Alarm status

If the pump detects an alarm, the LED switches from green to red. This can mean one of the following:

- low supply voltage
- blocked rotor
- electrical error.

The alarms for blocked rotor and electrical error can be read out via the PWM return signal, while all three alarms can be read out via the LIN bus signal.

UPM3 HYBRID variants

UPM3 HYBRID variants can be controlled both externally and internally.

Operating panel

The operating panel is designed with a single button, one red/green LED and four yellow LEDs.

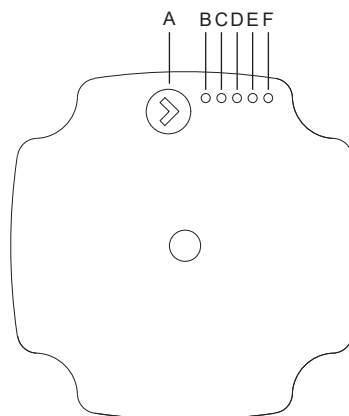

TM0605351

Operating panel with one button and five LEDs

Pos.	Description
A	Push button
B	LED 1
C	LED 2
D	LED 3
E	LED 4
F	LED 5

The operating panel shows:

- control mode
- alarm status.

Alarm status

If the pump detects one or more alarms, LED 1 switches from green to red and one of the other LEDs lights yellow.

If multiple alarms are active at the same time, the LEDs only show the error of the highest priority. The priority is defined by the sequence of the table as shown in the fault finding information.

When there is no active alarm anymore, the operating panel switches back to the operation mode.

Control modes

HYBRID control modes and curves

Up to five different control modes, each with up to four curves, are available for UPM3 HYBRID variants for different maximum heads.

Externally controlled		Internally controlled		
PWM A profile	PWM C profile	Proportional pressure	Constant pressure	Constant curve
Curve 1	Curve 1	Curve 1	Curve 1	Curve 1
Curve 2	Curve 2	Curve 2	Curve 2	Curve 2
Curve 3 (max.)	Curve 3 (max.)	Curve 3	Curve 3	Curve 3 (max.)
		AUTO _{ADAPT}	AUTO _{ADAPT}	

HYBRID variants

These setting options can be delivered as pre-configured variants.

Variant	Application	Functionality	Control modes and curves				Number of settings	Factory-preset
			Externally controlled	Internally controlled				
FLEX AS	Heating appliances	Runs with or without PWM signal. Without PWM signal, this pump runs on MAX curve.	PWM A	3	MAX	3	3	
SOLAR	Solar thermal systems	Runs with PWM C (solar) profile or on Constant curve.	PWM C	1	CC	3	4	
DHW	Domestic hot water systems	Runs with or without PWM signal. Without PWM signal, this pump runs on MAX curve.	PWM A	3	MAX	3	4	Depends on the pump type
AUTO	Heating kits DHW system	Runs with all self-controlled modes and curves.			PP CP CC	3+AA 3+AA 3	11	
HYBRID	Any HVAC system	Runs with all available modes and curves.	PWM A PWM C	3 1	PP CP CC	3+AA 3+AA 3	15	

Standard range

Overview of the standard range for UPM3.

UPM3S

UPM3S standard range												
Variant	Size	Max. H nom. [m]	Max. P1 nom. [W]	UPM3S standard range							Constant pressure	CP AUTO ADAPT
				Operating panel	PWM A profile	PWM C profile	LIN bus	Constant curve (CC)	Proportional pressure (PP)	PP AUTO ADAPT		
PWM	XX-40	4	25	•								
	XX-50	5	34	•								
	XX-60	6	42	•								
LIN	XX-60	6	42				•					
FLEX AS	XX-60	6	42	•	•			•				
AUTO	XX-60	6	42	•				•	•	•	•	
HYBRID	XX-60	6	42	•	•	•		•	•	•	•	

UPM3

UPM3 standard range												
Variant	Size	Max. H nom. [m]	Max. P1 nom. [W]	UPM3 standard range							Constant pressure	CP AUTO ADAPT
				Operating panel	PWM A profile	PWM C profile	LIN bus	Constant curve (CC)	Proportional pressure (PP)	PP AUTO ADAPT		
PWM	XX-50	5	33		•							
	XX-60	6	39		•							
	XX-70	7	52		•	•						
	XX-75	7.5	60		•	•						
LIN	XX-75	7.5	60				•					
FLEX AS	XX-50	5	33	•	•			•				
	XX-70	7	52	•	•			•				
	XX-75	7.5	60	•	•			•				
AUTO	XX-50	5	33	•				•	•	•	•	
	XX-70	7	52	•				•	•	•	•	
	XX-75	7.5	45	•		•						
SOLAR	XX-105	10.5	52	•		•						
	XX-145	14.5	60	•		•						
	XX-20	2	11	•	•			•				
DHW	XX-50	5	33	•	•			•				
	XX-70	7	52	•	•			•				
	XX-75	7.5	60	•	•			•				
HYBRID	XX-50	5	33	•	•	•		•	•	•	•	
	XX-70	7	52	•	•	•		•	•	•	•	

UPM3L

UPM3L standard range											
Variant	Size	Max. H nom. [m]	Max. P1 nom. [W]	Control modes, operating panel and settings							
				Operating panel	PWM A profile	PWM C profile	LIN bus	Constant curve (CC)	Proportional pressure (PP)	PP AUTO ADAPT	Constant pressure
PWM	XX-75	7.5	75		•						
LIN	XX-75	7.5	75				•				
FLEX AS	XX-75	7.5	75	•	•			•			
AUTO	XX-70	7	75	•				•	•	•	•
HYBRID	XX-70	7	75	•	•	•		•	•	•	•

UPMO

UPMO standard range											
Variant	Size	Max. H nom. [m]	Max. P1 nom. [W]	Control modes, operating panel and settings							
				Operating panel	PWM A profile	PWM C profile	LIN bus	Constant curve (CC)	Proportional pressure (PP)	PP AUTO ADAPT	Constant pressure
UPMO	XX-50	5	39	•	•			•			
	XX-60	6	60	•	•			•			
	XX-70	7	75	•	•			•			

UPMO

UPMO standard range					Factory preset															
Variant	Size	Max. H nom. [m]	Max. P1 nom. [W]	Operating panel	PWM A			PWM C			Constant curve			Proportional pressure				Constant pressure		
					A1	A2	A3	C1	C2	C3	CC 1	CC 2	CC 3	PP 1	PP 2	PP 3	AA PP	CP 1	CP 2	CP 3
UPMO	XX-50	5	39	•																
	XX-60	6	60	•																
	XX-70	7	75	•																

Changing the control mode

To set the product, use the button on the operating panel. Every time you press the button, the pump setting is changed. The LEDs indicate the chosen control mode.

Related information

[Overview of operating panel control modes](#)

Overview of operating panel control modes

All UPM3 HYBRID variants can be controlled with the button on the operating panel.

The LEDs on the operating panel shows the control mode.

Related information

[Changing the control mode](#)

[Ambient and liquid temperature](#)

UPM3 HYBRID

This pump is either for external PWM signal control with profile A or C or internal control with three control modes with AUTO_{ADAPT} (AA).

Control mode	LED1 green	LED2 green	LED3 yellow	LED4 yellow	LED5 yellow
PP AA	•				
CP AA		•			
PP1	•		•		
PP2	•		•	•	
PP3	•		•	•	•
CP1		•	•		
CP2		•	•	•	
CP3		•	•	•	•
CC1			•		
CC2			•	•	
CC3			•	•	•
PWM C signal off		• ¹	•	•	•
PWMC signal on		• ²	•	•	•
PWM A curve 1 signal off	• ¹		•		
PWM A curve 1 signal on	• ²		•		
PWM A curve 2 signal off	• ¹		•	•	
PWM A curve 2 signal on	• ²		•	•	
PWM A curve 3 signal off	• ¹		•	•	•
PWM A curve 3 signal on	• ²		•	•	•

¹ 1 flash per second.

² 12 flashes per second.

UPM3 FLEX AS and UPM3 DHW

This pump is either for external PWM A profile signal control or speed selection.

The maximum curve of the pump operation range can be defined.

- With PWM signal, the pump runs at the corresponding speed.
- Without PWM signal, the pump runs at maximum speed.

PWM A profile	LED1 green	LED2 green	LED3 yellow	LED4 yellow	LED5 yellow
PWM A curve 1 signal off	• ¹		•		
PWM A curve 1 signal on	• ²		•		
PWM A curve 2 signal off	• ¹		•	•	
PWM A curve 2 signal on	• ²		•	•	
PWM A curve 3 signal off	• ¹		•	•	•
PWM A curve 3 signal on	• ²		•	•	•

¹ 1 flash per second.

² 12 flashes per second.

UPM3 SOLAR

This pump is either for external PWM signal control with profile C or internal control on constant curve mode.

Control mode	LED1 green	LED2 green	LED3 yellow	LED4 yellow	LED5 yellow
CC1			•		
CC2			•	•	
CC3			•	•	•
PWM C signal off		• ¹	•	•	•
PWM C signal on		• ²	•	•	•

¹ 1 flash per second.

² 12 flashes per second.

UPM3 AUTO

This pump is for internal control with three control modes with AUTO_{ADAPT} (AA).

Control mode	LED1 green	LED2 green	LED3 yellow	LED4 yellow	LED5 yellow
PP AA	•				
CP AA		•			
PP1	•		•		
PP2	•		•	•	
PP3	•		•	•	•
CP1		•	•		
CP2		•	•	•	
CP3		•	•	•	•
CC1			•		
CC2			•	•	
CC3			•	•	•

UPMO

This pump is for internal control with control mode CC or for external PWM signal control with profile A.

The pump automatically enables the PWM input-signal control mode by SignalDetect when the signal cable is plugged in.

Control mode	LED1 green	LED2 green	LED3 yellow	LED4 yellow	LED5 yellow
CC1			•		
CC2			•	•	
CC3			•	•	•
PWM A	• ¹		•	•	•

¹ 12 flashes per second.

If the pump does not detect a PWM signal or if the signal equals 0, the pump returns to its previous control mode.

Control modes with pump curves

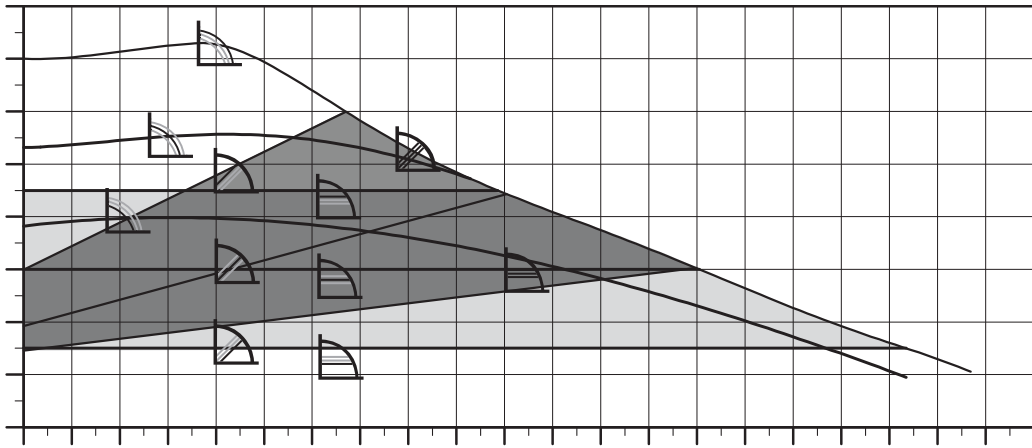

TM060803

UPM3 AUTO/HYBRID control modes with pump curves

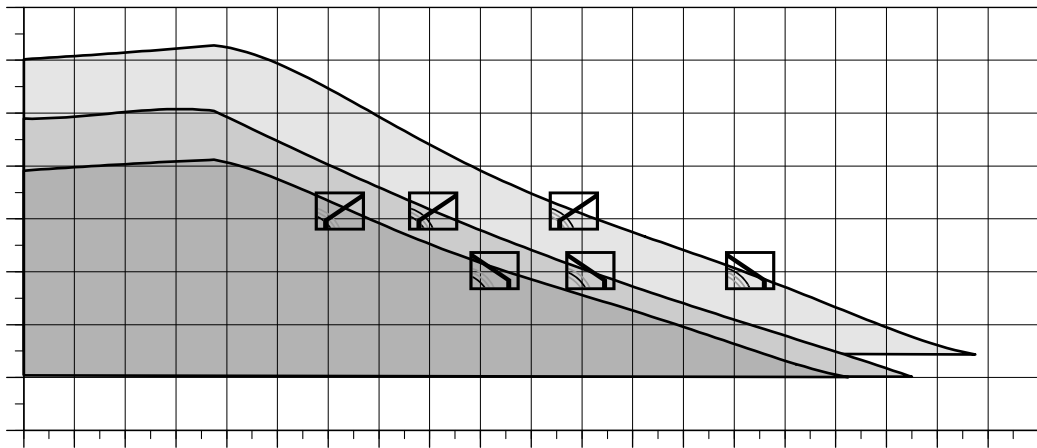

TM060804

UPM3 FLEX/HYBRID control modes with pump curves

Control mode explanation

Proportional pressure

The head (pressure) is reduced at falling heat demand and increased at rising heat demand.

The duty point of the pump moves up or down on the selected proportional-pressure curve depending on the heat demand in the system.



- PP1: lowest proportional-pressure curve
- PP2: intermediate proportional-pressure curve
- PP3: highest proportional-pressure curve
- $AUTO_{ADAPT}$: highest to lowest proportional pressure curve.

The $AUTO_{ADAPT}$ function enables the pump to control the pump performance automatically within a defined performance range:

- adjusting the pump performance to the size of the system.
- adjusting the pump performance to the variations in load over time.

In Proportional pressure $AUTO_{ADAPT}$, the pump is set to proportional-pressure control.

Constant pressure

The head (pressure) is kept constant, irrespective of the heat demand.

The duty point of the pump moves out or in on the selected constant-pressure curve depending on the heat demand in the system.



- CP1: lowest constant-pressure curve
- CP2: intermediate constant-pressure curve
- CP3: highest constant-pressure curve
- $AUTO_{ADAPT}$: highest to lowest constant-pressure curve.

The $AUTO_{ADAPT}$ function enables the pump to control the pump performance automatically within a defined performance range:

- adjusting the pump performance to the size of the system.
- adjusting the pump performance to the variations in load over time.

In constant pressure $AUTO_{ADAPT}$, the pump is set to constant-pressure control.

Constant curve

The pump runs on a constant curve, which means that it runs at a constant speed or power.

The duty point of the pump moves up or down on the selected constant curve, depending on the heat demand in the system.



TM060805

	Head [m]					
	UPM3 XX-20	UPM3 XX-50	UPM3 XX-70	UPM3 XX-75	UPM3 XX-105	UPM3 XX-145
CC1	1.0	3	5	5	6.5	8.5
CC2	1.5	4	6	6	8.5	10.5
CC3 (max.)	2	5	7	7.5	10.5	14.5

PWM A profile (heating)

The pump runs on constant speed curves depending on the current PWM value.

The speed decreases when the PWM value increases. If PWM equals 0, the pump runs at maximum speed.



TM060706

	Head [m]			
PWM profile	UPM3 XX-20	UPM3 XX-50	UPM3 XX-70	UPM3 XX-75
A1	1.0	3	5	5
A2	1.5	4	6	6
A3 (max.)	2.0	5	7	7.5
MAX	UPM3 XX-20	UPM3 XX-50	UPM3 XX-70	UPM3 XX-75
A1	1.0	3	5	5
A2	1.5	4	6	6
A3	2.0	5	7	7.5

PWM C profile (solar)

The pump runs on constant speed curves depending on the current PWM value.

Speed increases when the PWM value increases. If PWM equals 0, the pump stops.



TM060707

	Head [m]				
PWM profile	UPM3 XX-50	UPM3 XX-70	UPM3 XX-75	UPM3 XX-105	UPM3 XX-145
C1	3	5	5	6.5	8.5
C2	4	6	6	8.5	10.5
C3 (max.)	5	7	7.5	10.5	14.5

TM060704

TM060705

Pump control in heating systems

The heating required in a building varies greatly during the day due to changing outdoor temperatures, solar radiation and heat emanating from people, electric appliances, and other. In addition, the need for heating may vary from one section of the building to another and the thermostatic valves of some radiators may be turned down by the users. An uncontrolled pump produces too high differential pressure when the heat demand and flow are low.

Possible consequences are the following:

- too high energy consumption
- irregular control of the system
- noise in thermostatic radiator valves and similar fittings.

Grundfos UPM3 HYBRID and UPM3 AUTO automatically control the differential pressure by adjusting the pump performance to the actual heat demand, without external components.

Advantages of pump control

In Grundfos UPM3 HYBRID and UPM3 AUTO, pump control is effected by adapting the differential pressure to the flow (proportional-pressure and constant-pressure control). Contrary to an uncontrolled pump, a constant-pressure-controlled pump keeps the differential pressure constant. A proportional-pressure-controlled pump reduces the differential pressure as a result of falling heat demand.

For example:

If the heat demand falls, for instance, due to solar radiation, the thermostatic radiator valves closes, and, for the uncontrolled pump, the flow resistance of the system rises, for instance from A₁ to A₂.

In a heating system with an uncontrolled pump, this situation causes a pressure rise by ΔH_1 .

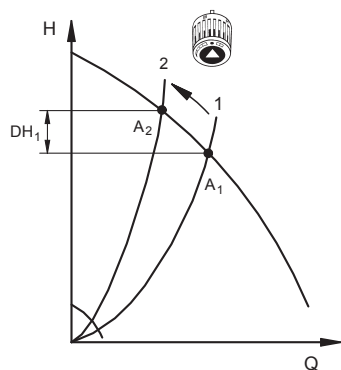

Uncontrolled pump

In a system with a proportional-pressure-controlled pump operated in the proportional pressure mode, the pressure is reduced by ΔH_2 , which result in reduced energy consumption.

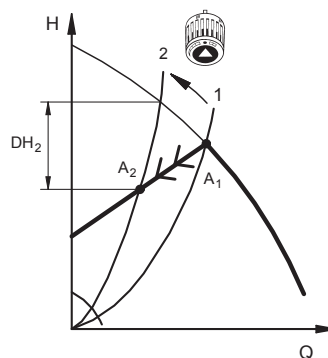

Pump operated in proportional-pressure control mode

In a system with an uncontrolled pump, a pressure rise often causes flow-generated noise in the thermostatic radiator valves. This noise is reduced considerably with proportional pressure control.

AUTO_{ADAPT}

Grundfos has held a patent for AUTO_{ADAPT} since 1995. With AUTO_{ADAPT}, the control curve is automatically adapted to the actual requirements of the respective application.

If you select AUTO_{ADAPT}, the pump starts with the medium proportional- or constant-control curve and runs on this curve as long as a new curve is adapted.

The AUTO_{ADAPT} proportional-pressure functionality is well known from millions of installed Grundfos trade pumps, such as ALPHA2 or MAGNA. The AUTO_{ADAPT} setting continually analyses and finds the setting where optimal comfort meets minimal energy consumption. It automatically delivers perfect comfort at the lowest possible energy level. It adapts to the requirements of the heating system before reaching the maximum pump curve and allows the pump to adjust the proportional-pressure or constant-pressure curve both up and down.

Advantages of AUTO_{ADAPT}

- Easy installation
- Automatic setting
- Demand-controlled operations
- Optimum comfort
- Energy savings
- Reduced CO₂ emissions.

Constant pressure at all load conditions is essential for how well the thermostatic valves can control the heat emission from the radiators. It is a well-known fact that optimum pump control in a two-pipe heating system with thermostatic radiator valves is best obtained by controlling pump pressure on a proportional-pressure curve. In underfloor heating or one-pipe systems it might be better to use constant-pressure control. However, predicting the best position in real-life applications is rather difficult, because the optimum position depends on correlated factors, such as the size of the heating system, the boiler type, the load condition, etc. This is where AUTO_{ADAPT} steps in to ensure that the pump is controlled in an optimum manner.

TM060858

TM060857

The AUTO_{ADAPT} algorithm

The objective of the AUTO_{ADAPT} algorithm is to measure and analyse the heating system during operation and adapt to the current heating pattern. The system adapts to night vs. day operations, summer vs. winter season, and heat losses or gains affecting room temperature, for example, from radiators, walls and windows, sun radiation, electrical equipment, and people.

AUTO_{ADAPT} three-step task

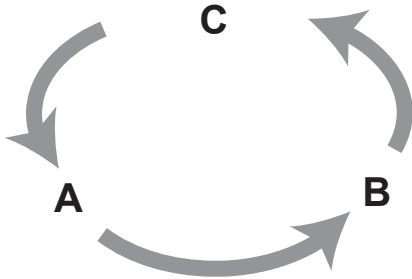

The AUTO_{ADAPT} three-step task

Pos.	Description
A	System analyser
B	Curve selector
C	Proportional or constant pressure control

Basically, AUTO_{ADAPT} optimises the position of the proportional or constant pressure curve via a three-step task as illustrated in the figure above.

The "system analyser" analyses the heating system which the pump is a part of. On the basis of the analysis, AUTO_{ADAPT} verifies whether the pump pressure is too high, too low or correct. The "curve selector" then uses this knowledge to select the optimum proportional- or constant-pressure curve for the pump. Finally, the pump is controlled according to the selected proportional- or constant-pressure curve of the "Proportional Pressure or Constant Pressure control". The pump continues this cycle as long as the pump is running.

Example

This example shows proportional pressure AUTO_{ADAPT}.

Note: The constant-pressure AUTO_{ADAPT} function uses constant-pressure control, and not proportional-pressure control, as shown in the example below.

The AUTO_{ADAPT} function can operate and adjust pump speed according to the duty point within a specific area. The arrow shows the maximum curve of the pump.

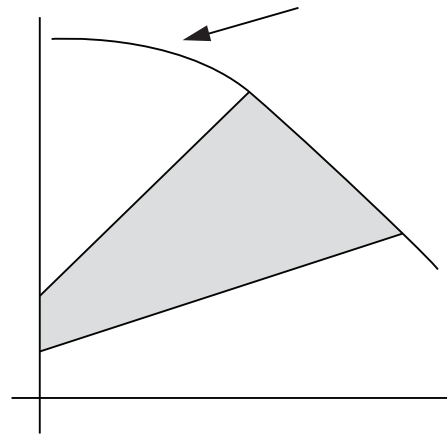

Proportional pressure AUTO_{ADAPT} operation area

By default, the AUTO_{ADAPT} is preset to operate the pump on the middle proportional pressure curve. By an immediate acting PI-controlling function, the pump adapts to the system on this proportional-pressure curve.

Note: The PI controller is set to eliminate any offset within a time frame of 120 seconds.

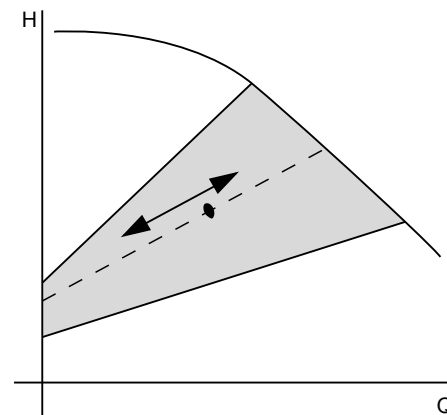

Proportional pressure control

System analyser

From the preset reference duty point, the pump immediately starts to analyse the heating pattern. The system resistance (K_{sys}) is logged and based on this data, a more optimal curve for operation is selected.

Note: $K_{sys} = m^3/h$ to create a system pressure loss of 1 bar.

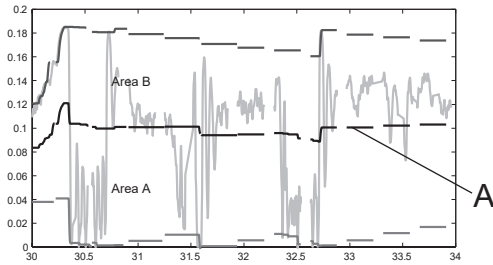

K_{sys}-values logged for the system analyser

Pos.	Description
X-axis	Time [days]
Y-axis	K-value
A	Reference duty point

If the actual duty point deviates from the reference duty point over time, the pump automatically adjusts its performance accordingly. If there is a tendency of operation in area A, the performance of the pumps is too high. The pump then selects a lower proportional curve. In other words, if the requirement of the heating system exceeds the reference duty point, the pump chooses a higher proportional-pressure curve. If the requirements are lower, a lower curve is chosen.

Curve selector

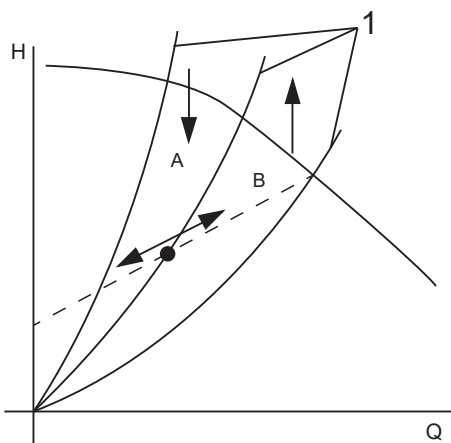

Duty point on selected proportional pressure curve

Pos.	Description
1	Reference curves

Note: The arrows indicate the change of the proportional-pressure curve.

New reference setting

When changing the proportional-pressure curve setting to adapt to the requirements of the heating system, $AUTO_{ADAPT}$ automatically sets a new reference duty point. From the new setting, the process starts over again: $AUTO_{ADAPT}$ continuously adapts to changes in the heating pattern.

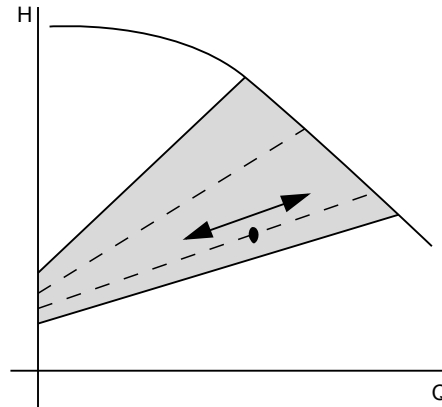

New lower proportional pressure curve

Selection of control mode

The selection of the control mode depends on the system type and the allocation of pressure losses defined by the valve or consumer authority.

System type		Recommended control mode	
Heating system with PWM control of the pump		PWM A profile 	
Solar system with PWM control of the pump		PWM C profile 	
System without PWM control of the pump (stand-alone)		Internally controlled	
Variable-flow system with relatively high pressure losses inside heating appliance and pipes (> 50 % of pump head)	Two-pipe systems with thermostatic radiator valve with low valve authority	$H_N > 2$ m for noise reduction Long distribution pipes High pressure losses in system parts with total flow Heat consumers with low pressure losses Proportional pressure / AUTO _{ADAPT} proportional pressure 	
	Primary pump	Primary circuit with high pressure losses	
	Variable-flow system with relatively low pressure losses inside heating appliance and pipes (< 50 % of pump head)	Two-pipe systems with thermostatic radiator valve with high valve authority	$H_N \leq 2$ m for noise reduction Former gravity systems Low pressure losses in system parts with total flow Heat consumers with high pressure losses Constant pressure / AUTO _{ADAPT} Constant pressure
		Floor heating system with variable flow	System with thermostatic zone valves
One-pipe system with variable flow		System with thermostatic radiator valves	
Primary pump		Primary circuit with low pressure losses	
Systems with low flow variation	Systems with minimum flow ensured by an automatic bypass valve		
Constant flow systems		Constant curve 	

8. Technical description

Exploded view and sectional view

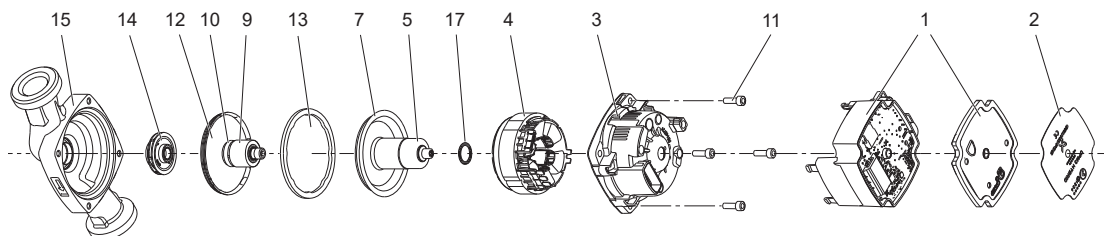

TM059245

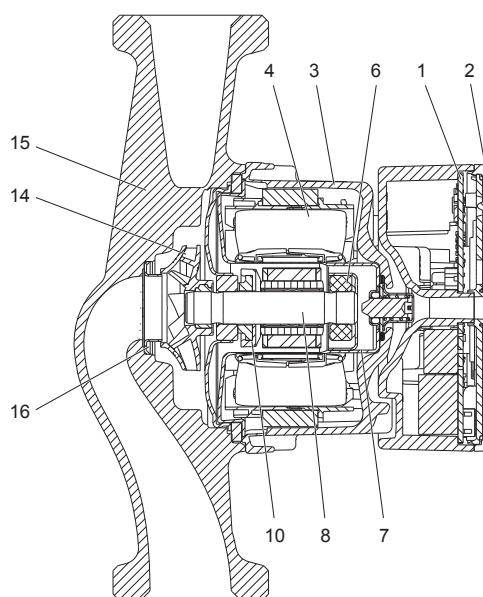

TM059246

Material specification

Pos.	Component	Material	EN/DIN
1	Control box	Composite PC-GF10 FR	
	Control electronics	PCB with SMD components	
2	Front foil	LEXAN 8A13F	
3	Stator housing	Aluminium, silumin	
	Stator	Copper wire	
4	Stator lamination	Laminated iron	
	Push deblocking device		
5	Plunger	Stainless steel	1.4404
	Spring	Stainless steel	1.4310
	Housing for spring	Stainless steel	1.4401
	Guide disc	Stainless steel	1.4401
	Housing for sealing	Stainless steel	1.4401
	Sealing	EPDM	
6	Radial bearing	Ceramics	
7	Rotor can	Stainless steel	1.4401

Pos.	Component	Material	EN/DIN
8	Shaft	Ceramics	
9	Rotor	NdFeB or injection-moulded ferrite	
	Rotor tube	Stainless steel	1.4521
	Rotor cladding	Stainless steel	1.4401/1.4301
	Bush	Stainless steel	1.4301
10	Thrust bearing	Carbon	
	Thrust bearing retainer	EPDM	
11	Screws	Steel	
12	Bearing plate	Stainless steel	1.4301
13	Gasket	EPDM	
14	Impeller	Composite/PES 20 or 30 % GF	

Pos.	Component	Material	EN/DIN
15	Pump housing	Cast iron GG15	EN-GJL-150
		Stainless steel	1.4308
		Composite PA 6.6 30 % GF	
16	Neck ring	Stainless steel	1.4301
17	O-ring	EPDM	

Description of components

The pumps are of the canned-rotor type as pump and motor form an integral unit without shaft seal and with only one gasket for sealing and four screws for fastening the stator housing to the pump housing. The bearings are lubricated by the pumped liquid as the rotor can is filled with water. The focus has been on using eco-friendly materials as well as on limiting the number of materials.

Motor description

The efficiency of the three-phase, 4-pole, synchronous, electronically commutated permanent-magnet (ECM/PM) motor type is considerably higher compared to a conventional asynchronous squirrel-cage motor.

The ECM/PM motor is designed according to the canned-rotor principle. The design of the mechanical motor components has mainly focused on the following features:

- reliable with stainless-steel rotor can in one part and a specific formed EPDM gasket
- simple design meaning as few components as possible, each with several functions
- high efficiency due to permanent magnets and low-friction bearings.

The motor is cooled by the pumped liquid, which reduces the sound pressure level to a minimum. Being software-protected, the pump requires no further motor protection.

Stator housing

The aluminium die-cast stator housing with four fixing holes is following the design of the well-accepted Grundfos UP pumps. It enables easy change of motor positions by removing the four screws holding the stator housing and turning the housing to the desired position. There are two versions: one without drain hole, as IP44, and one with one drain hole in two possible positions, as IPX4D. During operation, the drain hole must always point downwards. The pump is IP44 as standard for non-condensing applications and IPX4D in Solar variants. As K-variant for condensing applications, the stator housing IPX4D version is CED electrocoated.

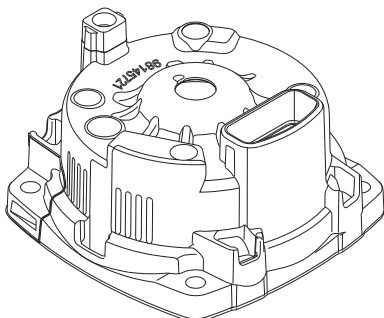

TM059258

Stator housing

Stator and windings

The product have a three-phase stator with six concentric-positioned in-slot windings.

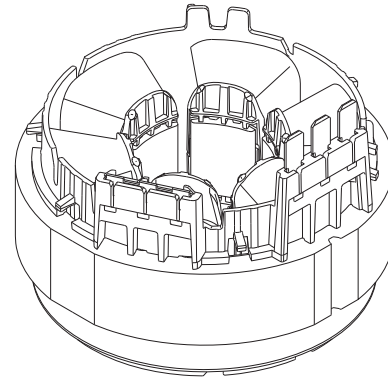

TM059260

Stator

Rotor can

The rotor can is drawn out of one sheet of stainless steel. It contains the ground and honed upper radial bearing. On top, the rotor can has a hole on which the deblocking device is welded.

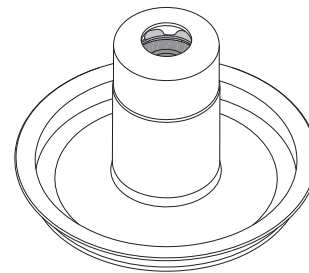

TM059247

Rotor can with bearing holder and ceramic bearing

Deblocking device

The deblocking device consists of an axial moving plunger tightened by an O-ring and pulled back by a spring inside a stainless-steel housing that is welded to the rotor can. The deblocking device is designed for pumps integrated in appliances to give access to the shaft from the front of the pump without having to demount the control box.

By pushing and turning a screw driver, Phillips No. 2, the plunger pushes the shaft in axial direction into the pump, while it can be turned as well. The force is high enough to deblock pumps that are seized by lime, for example, if an appliance is stored for months after being wet tested. Before, during and after deblocking, the device is tight and must not release any water.

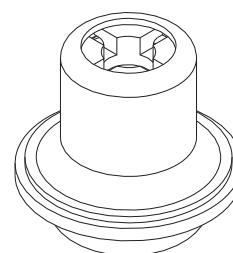

TM059253

Deblocking device

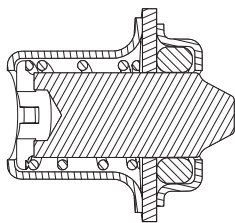

Sectional drawing of deblocking device

TM060291

Shaft with rotor

The shaft is made of ceramics. To avoid precipitation of calcium in the radial bearings, the shaft has been plunge-ground at the journal bearings. It has a through-going hole to ensure good lubrication and cooling of the upper bearing. The rotor can does not need to be vented as air inside the rotor chamber will escape the system through the through-going hole of the shaft.

The rotor core is either made of bonded neodymium permanent magnets, or injection-moulded with PPS bonded hard ferrite magnetic particles. The rotor is encapsulated in a thin stainless-steel cladding welded to the end covers. The rotor is fixed on the shaft by a back iron with a bush. After assembly, the whole unit is balanced.

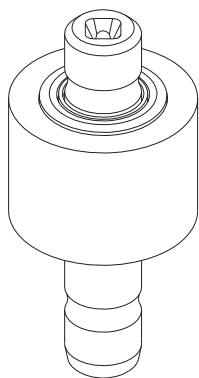

Shaft with rotor

TM059250

Thrust bearing

The antimony-free carbon thrust bearing is fitted to the shaft in a flexible EPDM retainer.

In combination with the bearing plate, the thrust bearing prevents forces from being transmitted axially to the rotor and rotor can.

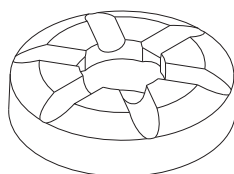

Thrust bearing

TM059252

Bearing plate

The bearing plate is made of stainless steel. The ground and honed inner radial and axial ceramic bearing is pressed into the bearing plate. The axial bearing is lapped to reduce any friction and the run-in period of the pump.

Due to the relatively large bearing plate surface, the motor heat is effectively carried away by the pumped liquid. Tiny laser holes through the bearing plate ensure optimum venting and minimise the gradual replacement of rotor liquid with the pumped liquid.

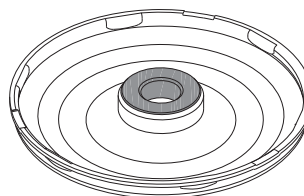

Bearing plate with ceramic bearing

TM059249

Impeller

The composite impeller is of the radial type with curved blades. The impeller shaft with rotor and bearing plate is assembled in one unit to eliminate possible misalignment in the bearings.

Three types of impellers are used:

- UPM3 Standard: diameter 38 mm, clearance 3 mm
- UPM3 SOLAR: diameter 52 mm, clearance 2.5 mm
- UPMO: diameter 48 mm, clearance 3 mm.

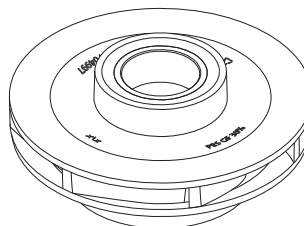

Impeller

TM059251

Moving unit

The unit is a pre-mounted combination of the shaft with a rotor, thrust bearing with a retainer, bearing plate and impeller. The moving unit is inserted into the rotor can with the upper radial bearing. The unit runs as a bearing system, ceramic/ceramic, with almost no wear as long as it is lubricated. During production, the unit is lubricated with glycerine. When the unit is mounted in a water-filled system, the system water lubricates the bearings. This guarantees the extremely reliable Grundfos ceramic bearing system of wet-running pumps.

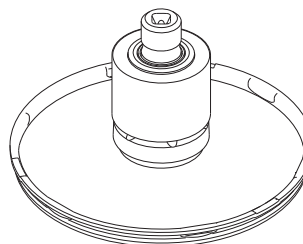

Moving unit

TM059256

Gasket

The gasket is a formed flat O-ring made of EPDM, which is applicable for drinking water use as well. The gasket seals up stator housing, pump housing, rotor can and bearing plate.

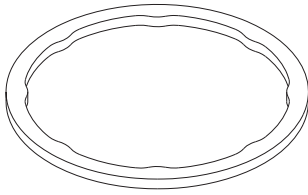

Gasket

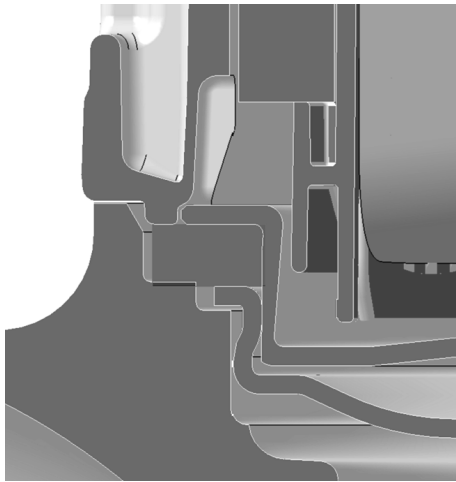

Sectional drawing showing sealing principle of gasket

TM059257

TM060846

Pump housing

As a standard, the pump housing is available in electrocoated cast iron with threaded inlet and outlet ports. The reference pump housing is of the in-line type. The stainless-steel neck ring is pressed into the pump housing to minimise the amount of liquid running from the outlet side of the impeller to the inlet side. A wide range of OEM-specific pump housings is available.

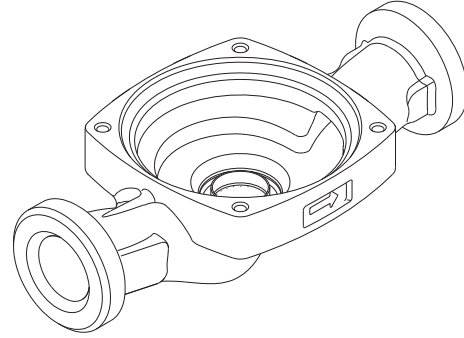

Pump housing

TM059254

OEM-specific housings

The products are available with a wide range of integrated standard housings or customised pump housings with different dimensions, in different materials, designs and with additional functionalities. Composite housings are mostly injection-moulded at the Grundfos factory using the tools designed and manufactured by Grundfos. The advantage of composite housings is the flexibility in forming complex housings and other hydraulic parts with low weight and production costs. Composite housings are limited to high-volume parts due to their high investment costs.

Related information

[Pump housing overview](#)

Control box

The control box housing is made of two composite parts welded together. Power and signal connectors are integrated. There are two versions available with signal connection designed for FCI connector or TE Mini Superseal connector.

The control box contains the PCBs for internal power supply, control, and communication. The control box includes all relevant functions and EMC filter components. It is available with different hard- and software, mainly different regarding internal or external control, with or without operating panel and communication signal as PWM.

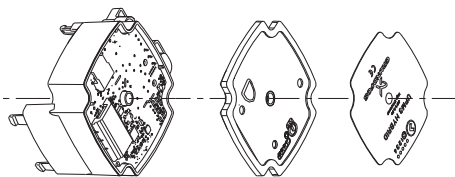

Control box

TM060826

Cast-iron electrocoated (CED) in-line housings with threads



TM064423

CED 15 x 130 mm



TM064424

CED 25 x 130 mm



TM064425

CED 25 x 180 mm



TM064426

CED 32 x 180 mm

Stainless-steel (N) in-line housings with threads - approved for drinking water use



TM068465

NIRO 15 x 130 mm



TM064427

NIRO 25 x 130 mm

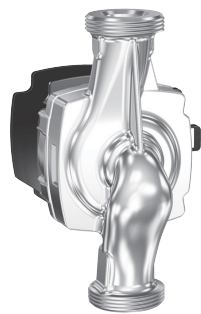

TM064428

NIRO 25 x 180 mm

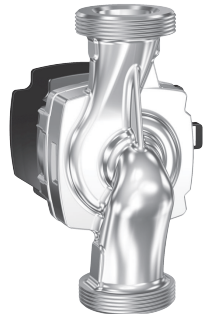

TM064429

NIRO 32 x 180 mm

Related information

[Pump housing overview](#)

Cast iron electrocoated (CED) OEM housings - end-suction with threads or in-line with air outlet

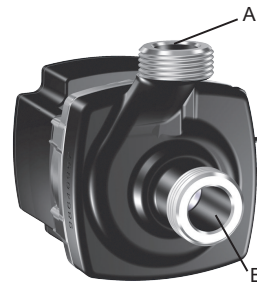

TM064430

GGES cast iron, end-suction

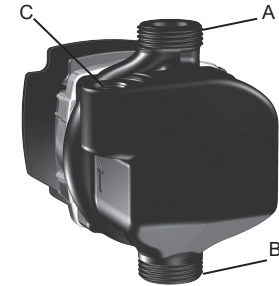

TM068467

GGES cast iron, end-suction

Pos.	Description
A	Outlet 1" thread connection
B	Inlet 1" thread connection
C	Air outlet 3/8" for external air vent

Cast iron electrocoated (CED) OEM housings - end-suction for back-panel mounting



TM064431

GGMBP3 cast iron, mini back-panel



TM064432

GGBP3 cast iron, maxi back-panel

Pos.	Description
A	Inlet Ø26 mm
B	Outlet Ø19 mm
C	Outlet Ø24.5 mm
D	Inlet Ø24.5 mm

Composite in-line housings with threads, integrated vent and additional connections

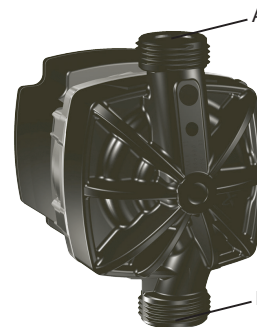

TM064433

CIL3 composite, in-line, 1" x 130 mm

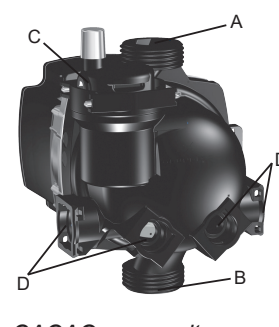

TM064434

CACAO composite, alternate connection, air outlet

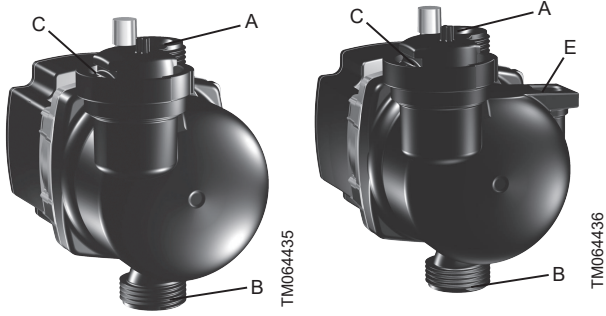

CIAO2 composite, in-line, air outlet

CIAO2 AC composite, in-line, air outlet, alternate connection

Pos.	Description
A	Outlet G 1 B (ISO 228/1) assembly torque 30 ± 10 Nm
B	Inlet G 1 B (ISO 228/1) assembly torque 30 ± 10 Nm
C	Air vent
D	Copper pipe connection, Ø14 mm, can be open or closed
E	Copper pipe connection, Ø10 mm, additional

Composite end-suction housings with threads or clips, with integrated vent and special connections

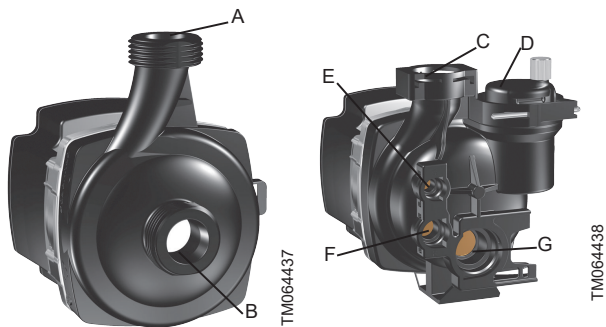

CES3 composite, end-suction

CESAO1 composite, end-suction, air outlet

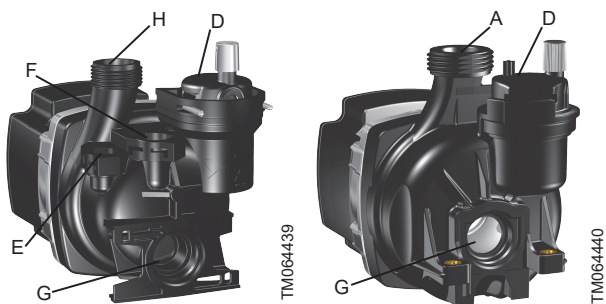

CESAO2 composite end-suction air outlet

CESAO4 composite end-suction air outlet

Pos.	Description
A	Outlet G 1 B (ISO 228/1) assembly torque 30 ± 10 Nm
B	Inlet G 1 B (ISO 228/1) assembly torque 30 ± 10 Nm
C	Outlet copper pipe connection Ø18 mm
D	Air vent

Pos.	Description
E	Connection for manometer or pressure sensor, Ø6 mm, can be opened or closed
F	Connection for manometer or pressure sensor, Ø10 mm, can be opened or closed
G	Inlet copper pipe connection Ø18 mm, fits Fugas brass block
H	Outlet G 3/4 B (ISO 228/1) assembly torque 25 ± 5 Nm

Composite in-line housings with threads or clips, with integrated vent, drain and special connections

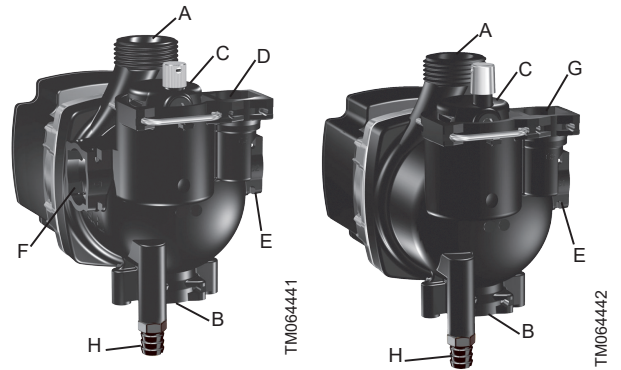

AOKR composite, air outlet, alternate connection, drain

CAOD composite, air outlet, drain

Pos.	Description
A	Outlet G 1 B (ISO 228/1) assembly torque 30 ± 10 Nm
B	Inlet Ø28 mm, with brass fitting
C	Air vent
D	Connection for manometer or pressure sensor Ø21 mm
E	Additional inlet hairpin side connection Ø28 mm
F	Additional inlet hairpin side connection Ø28 mm
G	Connection for expansion tank, etc. Ø21 mm
H	Drain

Pump housing overview

Material	Type	Product number	GG cast iron CED	N stainless steel	C PPS	C PA6.6	Weight [kg]	PN [bar]	Max. Temperature [°C]	Drinking water approvals	IL in-line	ES end suction	BP back panel	DN	Port-to-port length [mm]	Inlet	Outlet	ACC1	ACC2	ACC3	ACC4	AO air vent integrated	Drain valve
Cast iron CED PN 10	15 x 130 mm	98419166	•	-	-	-	0.7	10	110	-	•	-	-	15	130	G 1	G 1	-	-	-	-	-	-
	25 x 130 mm	98446965	•	-	-	-	0.9	10	110	-	•	-	-	25	130	G 1 1/2	G 1 1/2	-	-	-	-	-	-
	25 x 180 mm	98446967	•	-	-	-	1.0	10	110	-	•	-	-	25	180	G 1 1/2	G 1 1/2	-	-	-	-	-	-
	32 x 180 mm	98446970	•	-	-	-	1.2	10	110	-	•	-	-	32	180	G 2	G 2	-	-	-	-	-	-
Stainless steel, PN 10	N 15 x 130 mm	98930212	-	•	-	-	1.0	10	110	•	•	-	-	15	130	G 1	G 1	-	-	-	-	-	-
	N 25 x 130 mm	98601971	-	•	-	-	1.0	10	110	•	•	-	-	25	130	G 1 1/2	G 1 1/2	-	-	-	-	-	-
	N 25 x 180 mm	98601972	-	•	-	-	1.2	10	110	•	•	-	-	25	180	G 1 1/2	G 1 1/2	-	-	-	-	-	-
	N 32 x 180 mm	98601973	-	•	-	-	1.4	10	110	•	•	-	-	32	180	G 2	G 2	-	-	-	-	-	-
Cast iron CED PN 10	GGES3	98648502	•	-	-	-	1.1	10	110	-	-	•	-	15	65	G 1	G 1	-	-	-	-	-	-
	GGBP3	98648481	•	-	-	-	1.7	10	110	-	-	•	-	15	117	24.5	25	-	-	-	-	-	-
	GGMBP3	98662017	•	-	-	-	1.2	10	110	-	-	•	-	15	90	26.0	19.0	-	-	-	-	-	-
	GGAOS3	98924189	•	-	-	-	1.3	10	110	-	•	-	-	15	130	G 1	G 1	-	-	-	-	-	Rp 3/8
PPS PN 10	CIL3 PPS	98560033	-	-	•	-	0.2	10	95	•	•	-	-	15	130	G 1	G 1	-	-	-	-	-	-
	CIL3 PA 6.6	98560032	-	-	-	•	0.2	3	95	-	•	-	-	15	130	G 1	G 1	-	-	-	-	-	-
Composite PA 6.6 PN 3 (customised versions not included, available on request)	CES3	98651949	-	-	-	•	0.1	3	95	-	-	•	-	15	87	G 1	G 1	-	-	-	-	-	-
	CIAO2	98650878	-	-	-	•	0.2	3	95	-	•	-	-	15	130	G 1	G 1	-	-	-	-	-	•
	CIAO2 AC	98650880	-	-	-	•	0.2	3	95	-	•	-	-	15	130	G 1	G 1	10	-	-	-	-	•
	CACAO	98095186	-	-	-	•	0.2	3	95	-	•	-	-	15	130	G 1	G 1	14	14	10	10	-	•
	CESAO1	98672445	-	-	-	•	0.2	3	95	-	-	•	-	15	94	18	18	6	10	-	-	-	•
	CESAO2	97992027	-	-	-	•	0.2	3	95	-	-	•	-	15	94	G 3/4	18	6	10	-	-	-	•
	CESAO3	Coming soon																					
	CESAO4	98096544	-	-	-	•	0.3	3	95	-	-	•	-	15	87	G 1	18	-	-	-	-	-	•
	AOKR	59547502	-	-	-	•	0.3	3	95	-	•	-	-	15	128	G 1	28	28	28	21	-	-	•
	CAOD	98763350	-	-	-	•	0.3	3	95	-	•	-	-	15	128	G 1	28	28	21	-	-	-	•

Related information

[Domestic hot water recirculation](#)

[Gasket](#)

[Stainless-steel \(N\) in-line housings with threads - approved for drinking water use](#)

[Pumped liquids](#)

[Gaskets](#)

[Drinking water approvals](#)

Composite PA6.6 pumps with threaded flat sealings

Since 1989, Grundfos has been manufacturing and selling pump housings and integrated hydraulic units of polymeric composite, primarily PA6.6 with 30 % glass-fibre reinforcement. When using composite, the optimal design of connections is clip or hair-pin, because of their low internal stress-generating level.

For threaded connections, the full thread length must be used. The maximum assembly torque (e.g. 30 Nm ± 10) is mentioned in the specifications of the pump. We recommend to use EPDM gaskets.

To avoid overload, Grundfos does not recommend to use composite threads for standalone connections outside appliances.

All PA6.6 housings are defined as integrated. For integrated pumps, the respective pump heads are tested according to EN 16297/3 on a reference housing.

Expected lifetime of composite PA6.6 housings

The expected lifetime of composite PA6.6 housings in heating applications depends on the liquid temperature and the system pressure.

The liquid temperature must not exceed 95 °C.

For composite housings, Grundfos recommends that the system pressure does not exceed 3 bar (0.3 MPa), for cast iron housings 6 bar (0.6 MPa). For shorter periods of time, for example in fault scenarios, the composite housing can withstand 6 bar (0.6 MPa).

The expected lifetime also depends on the time or temperature profile of the application based on which an equivalent constant liquid temperature can be calculated. The influence of the liquid temperature between 60 °C and 95 °C on the expected lifetime is shown in the following diagram.

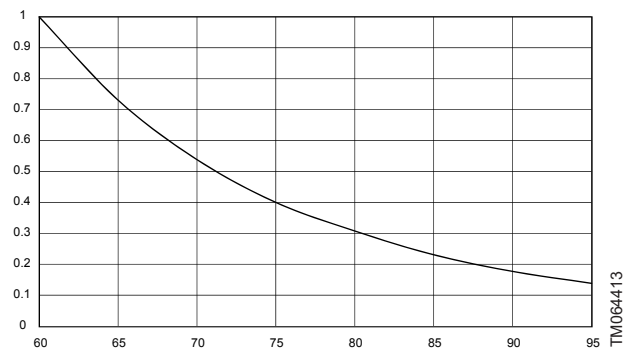

Diagram temperature/expected lifetime for PA 6.6 30 % GF

X-axis	Constant liquid temperature [°C]
Y-axis	Expected lifetime factor

Related information

[Ambient and liquid temperature](#)

Combination of housings for UPM3S control variants

UPM3 standard range		UPM3S						
		PWM			LIN	FLEX AS	AUTO	HYBRID
Housing		XX-40	XX-50	XX-60	XX-60	XX-60	XX-60	XX-60
Cast iron CED, PN 10	15 x 130 mm	•	•	•	•	•	•	•
	25 x 130 mm	•	•	•	•	•	•	•
	25 x 180 mm	•	•	•	•	•	•	•
	32 x 180 mm	•	•	•	•	•	•	•
Stainless steel, PN 10	N 15 x 130 mm	•	•	•	•	•	•	•
	N 25 x 130 mm	•	•	•	•	•	•	•
	N 25 x 180 mm	•	•	•	•	•	•	•
	N 32 x 180 mm	•	•	•	•	•	•	•
Composite PA 6.6, PN 3	GGES3	•	•	•	•	•		
	GGBP3	•	•	•	•	•		
	GGMBP3	•	•	•	•	•		
	GGAOS3	•	•	•	•	•		
	CIL3 PA 6.6	•	•	•	•	•		
	CES3	•	•	•	•	•		
	CIAO2	•	•	•	•	•		
	CIAO2 AC	•	•	•	•	•		
	CACAO	•	•	•	•	•		
	CESAO1	•	•	•	•	•		
	CESAO2	•	•	•	•	•		
	CESAO3 (coming soon)	•	•	•	•	•		
	CESAO4	•	•	•	•	•		
	AOKR	•	•	•	•	•		
CAOD	•	•	•	•	•			

Combination of housings for UPM3 control variants

UPM3 standard range		UPM3																			
		PWM				LIN	FLEX AS			AUTO			SOLAR		DHW			HYBRID			
Housing		XX-50	XX-60	XX-70	XX-75	XX-75	XX-50	XX-70	XX-75	XX-50	XX-70	XX-75	XX-105	XX-145	XX-20	XX-50	XX-70	XX-50	XX-60		
Cast iron CED, PN 10	15 x 130 mm	•	•	•	•	•	•	•	•	•	•	•							•	•	
	25 x 130 mm	•	•	•	•	•	•	•	•	•	•	•								•	•
	25 x 180 mm	•	•	•	•	•	•	•	•	•	•	•								•	•
	32 x 180 mm	•	•	•	•	•	•	•	•	•	•	•								•	•
Cast iron CED, PN 10, for SOLAR	S 15 x 130 mm												•	•							
	S 25 x 130 mm												•	•							
	S 25 x 180 mm												•	•							
Stainless steel, PN 10	N 15 x 130 mm	•	•	•	•	•	•	•	•	•	•	•			•	•	•	•	•	•	•
	N 25 x 130 mm	•	•	•	•	•	•	•	•	•	•	•			•	•	•	•	•	•	•
	N 25 x 180 mm	•	•	•	•	•	•	•	•	•	•	•			•	•	•	•	•	•	•
	N 32 x 180 mm	•	•	•	•	•	•	•	•	•	•	•			•	•	•	•	•	•	•
PPS, PN 10	CIL3 PPS	•	•	•	•	•	•	•	•	•	•				•	•	•				
Composite PA 6.6, PN 3	GGES3		•	•	•	•	•	•	•				•								
	GGBP3		•	•	•	•															
	GGMBP3		•	•	•	•	•	•	•				•								
	GGAOS3		•	•	•	•	•	•	•				•								
	CIL3 PA 6.6		•	•	•	•	•	•	•				•								
	CES3		•	•	•	•	•	•	•				•								
	CIAO2		•	•	•	•	•	•	•				•								
	CIAO2 AC		•	•	•	•	•	•	•				•								
	CACAO		•	•	•	•	•	•	•				•								
	CESAO1		•	•	•	•	•	•	•				•								
	CESAO2		•	•	•	•	•	•	•				•								
	CESAO3 (coming soon)		•	•	•	•	•	•	•				•								
	CESAO4		•	•	•	•	•	•	•				•								
	AOKR		•	•	•	•	•	•	•				•								
	CAOD		•	•	•	•	•	•	•				•								

Combination of housings for UPM3L control variants

UPM3 standard range		UPM3L				
		PWM	LIN	FLEX AS	AUTO	HYBRID
Housing		XX-75	XX-75	XX-75	XX-70	XX-70
Cast iron CED, PN 10	15 x 130 mm	•	•	•	•	•
	25 x 130 mm	•	•	•	•	•
	25 x 180 mm	•	•	•	•	•
	32 x 180 mm	•	•	•	•	•
Stainless steel, PN 10	N 15 x 130 mm	•	•	•	•	•
	N 25 x 130 mm	•	•	•	•	•
	N 25 x 180 mm	•	•	•	•	•
	N 32 x 180 mm	•	•	•	•	•
PPS, PN 10	CIL3 PPS	•	•	•		
Composite PA 6.6, PN 3	GGES3	•	•	•		
	GGBP3	•	•	•		
	GGMBP3	•	•	•		
	GGAOS3	•	•	•		
	CIL3 PA 6.6	•	•	•		
	CES3	•	•	•		
	CIAO2	•	•	•		
	CIAO2 AC	•	•	•		
	CACAO	•	•	•		
	CESAO1	•	•	•		
	CESAO2	•	•	•		
	CESAO3 (coming soon)	•	•	•		
	CESAO4	•	•	•		
	AOKR	•	•	•		
	CAOD	•	•	•		

Combination of housings for UPMO control variants

UPM3 standard range		UPMO		
Housing		XX-50	XX-60	XX-70
Cast iron CED, PN 10, for UPMO	O 15 x 130 mm	•	•	•
	O 25 x 130 mm	•	•	•
	O 25 x 180 mm	•	•	•

9. Installation

Pumped liquids



The pump must not be used for circulation of flammable liquids, such as diesel oil and petrol.



There is a risk of malfunction or damage when inhibitors or additives are added to the pumped liquids.

The pump is suitable for the following liquids:

- Clean, thin, non-aggressive and non-explosive liquids, not containing solid particles or fibres.
- In heating systems, the water must meet the requirements of accepted standards on water quality in heating systems, for example the German standard VDI 2035.
- The pH must be between 8.2 and 9.5. The minimum value depends on the water hardness and must not be below 7.4 at 4 °dH (0.712 mmol/l).
- The electrical conductivity at 25 °C must be ≥ 10 microS/cm.
- Mixtures of water with antifreeze media, such as glycol, with a kinematic viscosity lower than 10 mm²/s (10 cSt). When selecting a pump, the viscosity of the pumped liquid must be taken into consideration. If the pump is used for a liquid with a higher viscosity, the hydraulic performance of the pump is reduced.

- Solar media as used in typical solar thermal systems containing up to 50 vol % of antifreeze media.



Frost protection fluids may contain substances that can harm the terminal box material.

- For drinking water use, approved housings must be used, such as CIL3 PPS or stainless steel N. These pumps and the in contact with water are approved by WRAS (UK), ACS (FR), and comply to the applicable evaluation criteria issued by UBA (DE).
- In domestic hot-water systems, the pump must be used only for water with a degree of temporary hardness of less than 3 mmol/l CaCO₃ (16.8 ° dH). To avoid lime problems in hard waters, the medium temperature must not exceed 65 °C.
- The water quality of test beds for the final production tests of complete heating appliances including pump must be observed to avoid calcification or biofilm formation during a longer storage period.

Related information

[Pump housing overview](#)

Ambient and liquid temperature

The ambient and liquid temperature of the specific pump is indicated in the table below. The ambient temperature is measured in a distance of not more than 5 cm in front of the front foil at its lower edge.

		55 °C ambient at a 95 °C liquid temperature.	70 °C ambient at a 65 °C liquid temperature.	70 °C ambient at a 110 °C liquid temperature.	60 °C ambient at a 130 °C liquid temperature.	95 °C ambient temperature
Standard variants						
GFNHB	UPM3S			•	•	•
GFNKB	UPM3			•	•	•
GFNKC	UPM3L	•		•	•	•
Flammable refrigerant environment variants						
GFNHF	UPM3S	•	•			
GFNKG	UPM3	•	•			
GFNKH	UPM3L	•				

The above-mentioned temperature ranges do not take temperature limitations of the drinking water approvals into account.

- UPM3, IP44 above dew point of ambient air: min. 2 °C
- UPM3, IP4XD as K version with drain hole: min. -10 °C.

Related information

[Overview of operating panel control modes](#)

[Expected lifetime of composite PA6.6 housings](#)

[Storing and transporting the product](#)

Relative humidity

IP44: The relative humidity must not exceed 95 % in a non-condensing environment.



The dew point of the air at ambient temperature should always be lower than the liquid temperature, otherwise condensation may form in the stator housing.

K-Version/IPX4D: Condensation is acceptable.

Minimum inlet pressure

To avoid cavitation noise and damage to the pump bearings, the following minimum pressures are required at the pump inlet port.

Liquid temperature	75 °C	95 °C	110 °C
Pressure	0.005 MPa	0.05 MPa	0.108 MPa
	0.05 bar	0.5 bar	1.08 bar

Storing and transporting the product

- Observe the permissible ambient conditions.
- Observe the permissible storage temperature: -40 to +75 °C.
- Protect the storage location from rain, humidity, condensation, direct sunlight and dust.
- Observe the maximum storage time (without power supply): 2 years from delivery.
- Use appropriate lifting and transporting devices.
- Observe the maximum stacking height of pallets.

Disregard of the safety instructions may have dangerous consequences for persons, the environment and the product.

Related information

[Ambient and liquid temperature](#)

Mechanical installation



Mechanical installation must be carried out by trained persons in accordance with local regulations.



The pump must always be installed with horizontal motor shaft within $\pm 5^\circ$.



Arrows on the pump housing indicate the liquid flow direction through the pump. The pump is designed to be installed with horizontal shaft pumping upwards, downwards or horizontally.

For mounting dimensions, see the data sheets.

- The pump must be installed in the system in such a way that no major amount of air flowing through or gathering in the pump housing affects the pump when it is out of operation.
- If an additional non-return valve is installed in the flow pipe, there is a high risk of dry running, because the air cannot pass the valve.
- It must be possible to vent the system at the highest part of each system segment.
- Permanent venting is recommended.

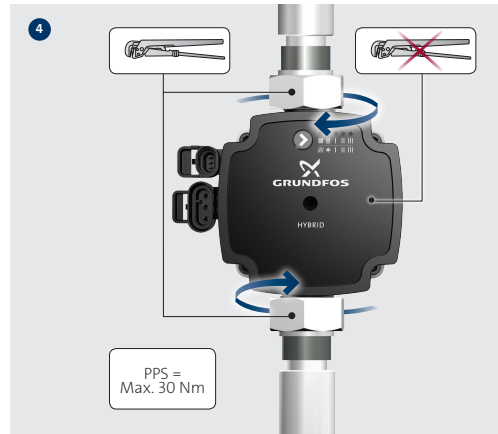
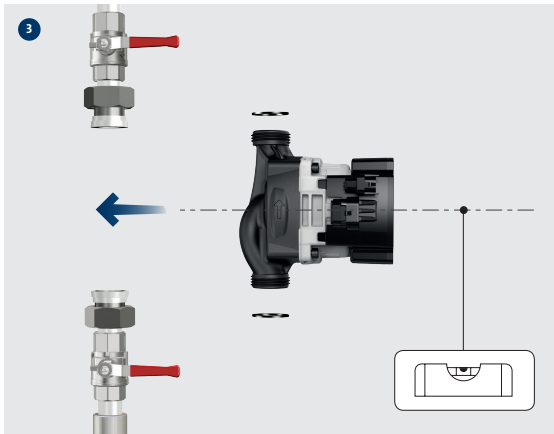
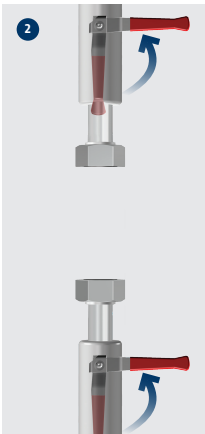
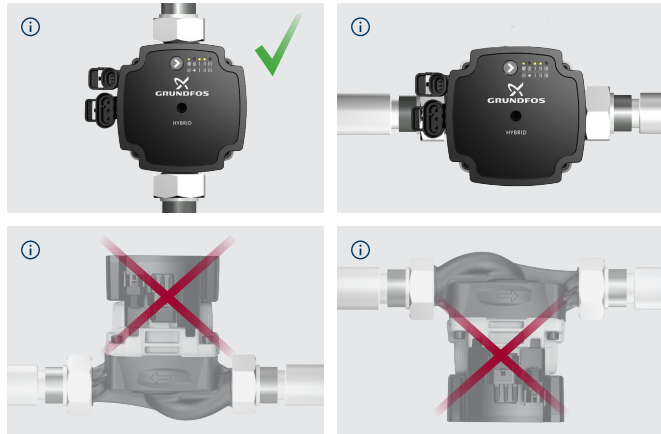
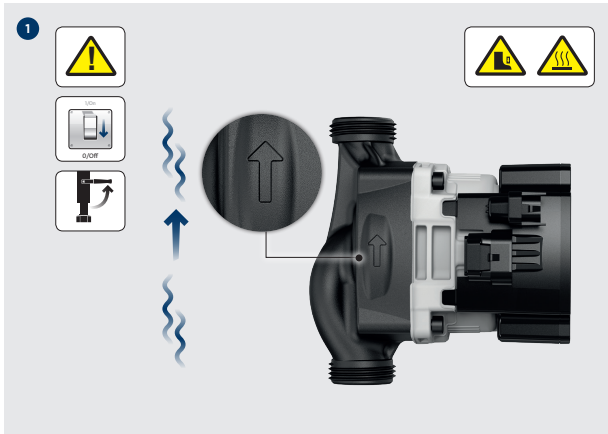

TM064412

Mechanical installation

Control box positions

The control box gives access to the terminals from the front. If necessary, you can turn the control box in steps of 90 degrees:

- 3 o'clock
- 6 o'clock
- 9 o'clock
- 12 o'clock.

By default, the operating panel is in the top position (12 o'clock) when the terminals are in 9 o'clock position. The front foil can be placed in four different positions. This allows you to place it in a horizontal position no matter the orientation of the control box.

Observe the following:

- IP44 versions without drain holes - all positions are allowed.
- IPX4D versions with drain holes (UPM3K, UPM3 SOLAR) - the drain hole must point downwards after installation. Only connector positions to the side are possible.

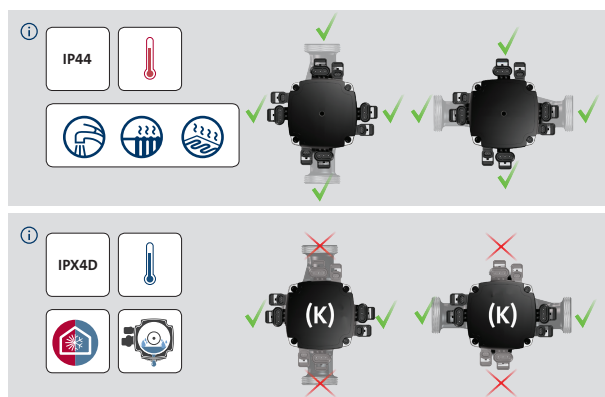

TM064409

Changing the control box position

1. Remove the screws that hold the pump head.
2. Turn the control box into the desired position.
3. Fit the screws.
4. Tighten the new screws securely.

The nameplate position cannot be changed.



Before dismantling the pump, drain the system or close the isolating valves on both sides of the pump.

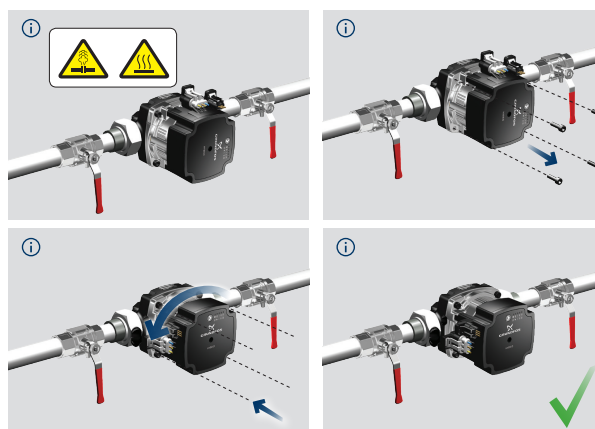

TM064410

Changing the control box position

Insulation

When insulating the pump, the front plate of the control box must not be covered in order to allow for cooling by the surrounding air.

If the pump is installed inside a cabinet, a boiler or a heating kit encapsulated with insulation shells, the inside air temperature has to be measured and it must not exceed 70 °C during operation.



TM064411

Insulation of a pump

Preventing the pump from blocking

To prevent the pump from blocking, do as follows:

1. Once installation is complete, the pump must run for two hours to vent the system.
2. Make sure that the pump runs for a period of time every day.

10. Electrical connection



All electrical connections must be carried out by a qualified electrician in accordance with local regulations.



The pump is not a safety component and cannot be used to ensure functional safety in the final appliance.

- The pump requires no external motor protection.
- Check that the supply voltage and frequency correspond to the values stated on the nameplate.
- The pump must not be used with an external speed control that varies the supply voltage.
- If an earth leakage circuit breaker is used, check which type it is.
- If an external relay is used, check if it can stand the inrush current.

Supply voltage

1 x 230 V + 10 %/- 15 %, 50/60 Hz.

The pump is externally controlled via PWM signal or LIN bus signal, or internally speed-controlled by a frequency converter. Therefore, the pump must not be used with an external speed control that varies the supply voltage, for example phase-cut or pulse-cascade control.

Reduced supply voltage

The pump operation is ensured above 160 VAC with reduced performance.

Pumps with PWM and LIN bus control

If the voltage falls below 190 VAC, a low voltage warning is sent via the PWM or LIN bus signal.

If the voltage falls below 150 VAC, the pump stops and a low voltage alarm is sent via the PWM or LIN bus signal.

Pumps in internal control mode

If the voltage falls below 150 VAC, the pump stops and shows an alarm.

Supply voltage	Pump performance	Status LED	PWM output signal
230 VAC	Running	Green	According to specification.
<195 VAC	Reduced	Green	Warning
<150 VAC	Stopped	Red	Alarm*

* The pump starts again when the voltage is above 160 VAC and the PWM output changes to either warning or according to specification depending on the level.

Earth leakage circuit breaker (ELCB)

Leakage current

The pump mains filter causes a leakage current to earth during operation.

Leakage current: < 3.5 mA.

High-voltage test

All Grundfos pumps are tested with 1000 VAC for 1 second, according to EN 60335-1 Annex A.

ECM pumps incorporate filter components (including Y-capacitors) that are connected to protective earth. The capacitors are class Y2 film capacitors with normal requirements. Every high-voltage test exposes the Y-capacitors to high voltage.

The voltage level and the amount of tests should be as low as possible, in order to allow for the longest lifetime in the market. Additional standard high-voltage tests of the complete pump, including filter, should be avoided to eliminate the risk of filter damage.

Inrush current

All electronic pumps contain electronic units that must be protected by filters, including capacitors and ECM pumps frequency converters with AC/DC rectifiers containing capacitors, to equalize the waves. This is not the case in most asynchronous pumps.

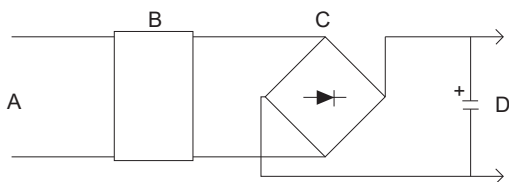

TM060822

Rectification of VAC voltage to DC voltage

Pos.	Description
A	Mains
B	EMC filter
C	Rectifier
D	Bulk capacitor

The load of electronically commutated motors (ECM) behaves as a capacitive load and not as a motor load like in a standard pump.

At start, the capacitor is unloaded. Up to this point, the amplitude of the current peak depends on the grid impedance, until the capacitor is charged. The faster the capacitor is charged, the higher the amplitude gets, and the faster the pump can be started. After this period of time, the current drops to the rated current.

Definition: Inrush current is the current peak charging the capacitors in the electronics when the supply voltage is connected.

Note: When discussing measurements, it is important to refer to the same method. Since 2007, Grundfos uses the IEC 61000-3-3 Annex B method for measuring inrush current.

The inrush current peak charges the bulk capacitor to 325 VDC as fast as the power grid allows. It shows that inrush current does not only depend on the integrated electronics but also on the impedance of the grid.

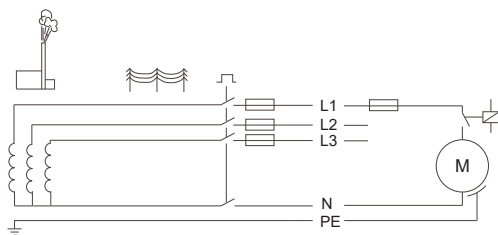

TM060819

If you use a relay to switch the power supply of the pump, you risk excessive wear on the relay contact surface.

To avoid such problems, there are various external and internal solutions.

External solutions in the controller of the appliance unit

- Specific relays with silver tin oxide (AgSnO₂) inrush relay contacts.
- Switching at ZERO crossing.
- Standby operation - pump only switches via the PWM signal.

Internal solutions in the pump

- NTC resistor in the power input circuit (passive).
- Bypass relay with PTC resistor or solid state inrush reduction controlled by the electronics (active).

Related information

[NTC resistor \(passive option\)](#)

[Relay and PTC \(active - standard for UPM3 HYBRID variants\)](#)

NTC resistor (passive option)

We recommend that you use this option for pumps that are permanently connected to the grid and switched on or off by external PWM signal.

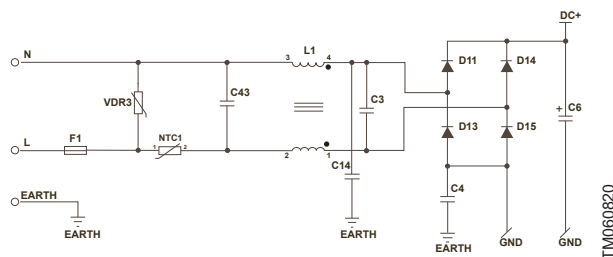

TM060820

NTC option

At startup, the operating temperature of the pump, including the NTC resistor, is low. In this situation the NTC resistor has a high resistance and is able to limit the inrush current to ~ 10 A.

During operation, the operating temperature of the pump, including NTC resistor, is high. There is no inrush current but the NTC resistance decreases so that the loss is limited.



At restart, the operator must ensure that the NTC resistor has cooled down so that efficient operation is guaranteed. Normally, it takes one minute for the resistor to cool down.

When the power supply to the pump is switched on and off via an external relay, it must be ensure that the contact material of the relay is able to handle higher inrush currents.

Related information

[Internal solutions in the pump](#)

[Relay and PTC \(active - standard for UPM3 HYBRID variants\)](#)

Relay and PTC (active - standard for UPM3 HYBRID variants)

We recommend that you use this option for pumps that are not in permanent operation and can be interrupted by a relay of the controller of the appliance.

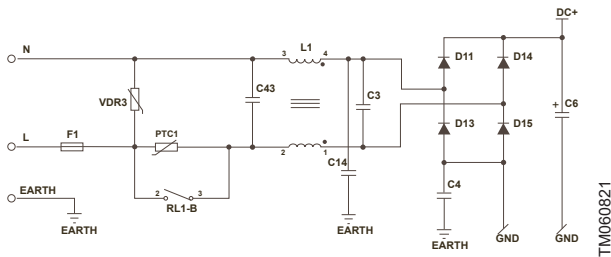

Relay

At startup, the relay is open. In this mode, the PTC resistor is able to limit the inrush current to a level of approximately 4 A.

During operation, the relay is closed. In this mode the resistor is bypassed so that efficient operation is guaranteed.



The inrush current is measured on a flicker network according to IEC 61000-3-3:1994 + A1, + A2, Annex B.

Related information

[Internal solutions in the pump](#)

[NTC resistor \(passive option\)](#)

Control box connections

All control boxes have two electrical connections on one side: power supply and signal connection. If the signal connection is not needed, it can be covered by a blind plug (available as an accessory).

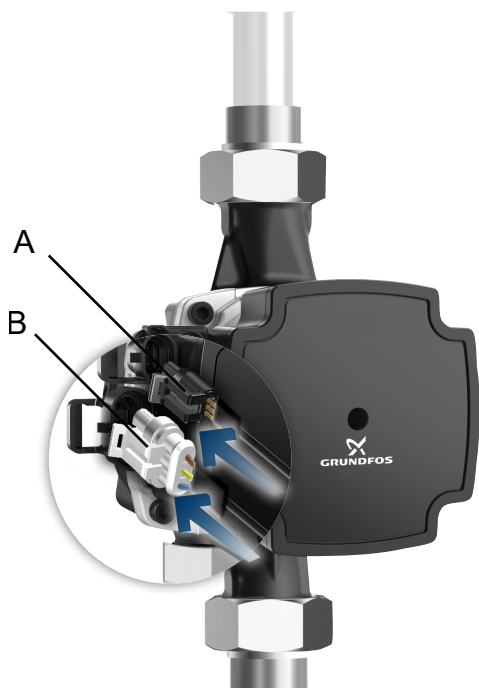

TM079640

Signal connection and power connection

Pos.	Description
A	Signal connection
B	Power connection

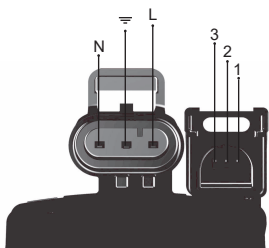

Connections FCI

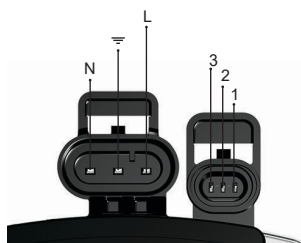

Connections Mini SS

Contact	PWM	LIN	Cable
1	PWM input	VBAT	Brown
2	Signal reference	Signal reference	Blue
3	PWM output	LIN bus signal	Black

TM064416



Control box without signal connection

TM079641

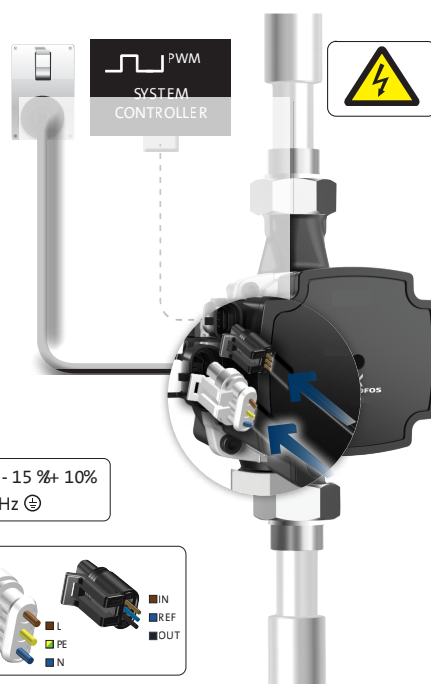

Control box with Mini SS connection

TM079642

Power supply connection

The pump must be connected to the power supply with the TE Superseal connector. Adapters are available for cables with Molex or Volex connectors.

TE Superseal power connector

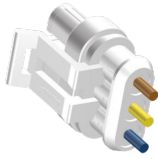

TM064415

TE Superseal power connector

Reliability

- Temperature-proof and fireproof glow wire
- Waterproof.

Safety

- Additional locking latch with pull-out force > 100 N
- Lock can only be opened with a screwdriver.

Availability

Worldwide according to TE standard.

Superseal installation plug

The Grundfos Superseal installation plug can be used to mount a supply cable locally. The Superseal installation plug incorporates cable relief and a locking function for securing the connection of the supply cable. The cover of the Superseal installation plug can be mounted in two different positions: with the cable relief away from the pump or in parallel.

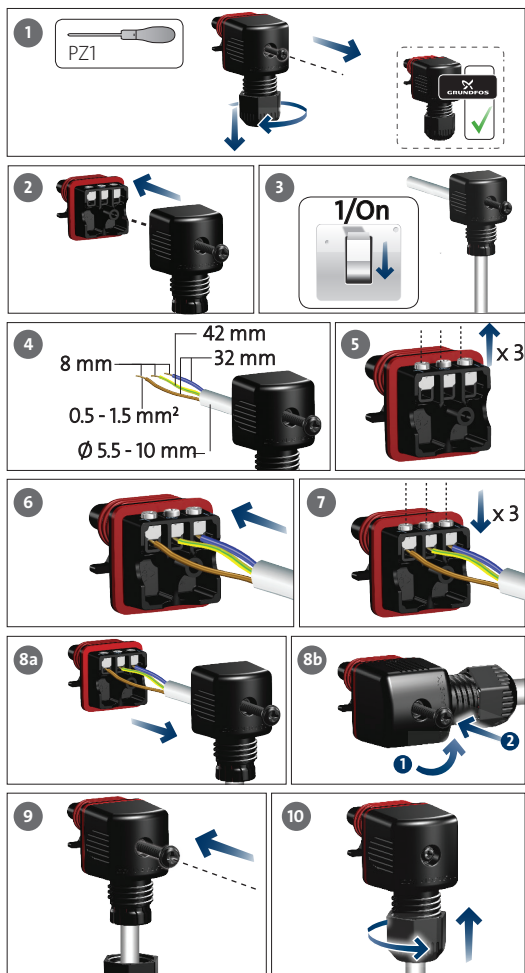

TM078802

Superseal installation plug

Control signal connection



Connect the signal wires to the correct poles. Otherwise, the pump may be damaged.

The pumps are externally speed-controlled. A signal cable is required to enable the pump control. Otherwise, the pump with profile A runs continuously at maximum speed, while the pump with profile C stops.

UPM3 HYBRID pumps are either internally or externally speed-controlled.

If you set the pump to external control mode (PWM A or C profile) via the operating panel, you need a signal cable. If you set the pump to internal control mode, a blind plug is available to close the signal connection.

The signal cable connection has three leads: signal input, signal output and signal reference. The cable must be connected to the control box either by FCI or TE Mini Superseal connector. The optional signal cable can be supplied with the pump as an accessory.

The cable length can be customised to specific requirements (max. 3 m).

TE Mini Superseal connector



TM064414

TE Mini Superseal connector

Safety

- Additional locking latch with pull-out force > 100 N
- Lock can only be opened with a screwdriver.

Availability

Worldwide according to TE standard.

Grundfos FCI (for UPER/UPM)

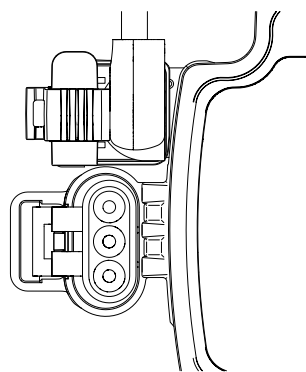

TM064417

Grundfos FCI for UPER/UPM

Backwards compatibility

It is intended for replacement of UPER/UPM pumps or in appliances that use FCI plug, for example, cable trees.

Safety

Two-part design: separate lock is needed to meet the pull-force requirements > 100 N.

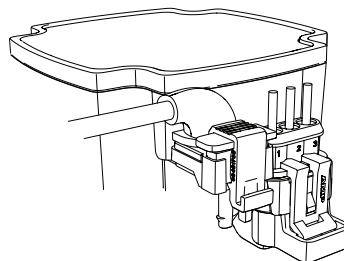

TM064418

FCI signal cable fixed by a separate lock

Availability

Many cable suppliers use these cable connections.

Overview of technical data

Feature	Specification
Nominal supply voltage	EU: 1 x 230 V + 10 %/- 15 %, 50/60 Hz
Minimum supply voltage	160 VAC (runs with reduced performance)
Motor protection	The motor is protected by the electronics in the control box and requires no external motor protection
Enclosure class	IP44 (standard without drain holes), K-version: IPX4D (with drain holes)
Equipment class	I (EN 60335-1)
Insulation class	F (EN 60335-1)
Temperature class	TF110 at 70 °C ambient temperature UPM3L: TF95 at 55 °C ambient temperature
High voltage protection	EN 60335-1 1000 VAC
Maximum ambient temperature	70 °C at 110 °C or 60 °C at 130 °C. UPM3L: 55 °C at 95 °C
Maximum media temperature	95 °C for composite housings, 110 °C/130 °C for cast iron housings
Minimum media temperature	2 °C (IP44: above dew point of ambient air), K version: -10 °C
Storage temperature	-40 to +75 °C
Maximum system pressure	1 MPa (10 bar) (depending on the housing material)
Minimum inlet pressure	0.005 MPa (0.05 bar) at 75 °C liquid temperature 0.05 MPa (0.50 bar) at 95 °C liquid temperature 0.108 MPa (1.08 bar) at 110 °C liquid temperature
Flow estimation	Available depending on the housing, accuracy: see PWM specification
Drinking water approvals (ACS, WRAS, UBA)	All pump head components are compliant, except for UPM3S. Specific compliant pump housings are available
Deblocking device	Manual deblocking device, access from front side
Deblocking software	Continuously restarting with relay after 1.33 seconds, with NTC every 0.3 - 0.4 seconds with max. torque
Dry run ability - first start	3 x 20 seconds (5 minutes interval), all pumps are lubricated with glycerine
Dry run ability - during operation	Rotor can must be filled with water: meets EN 60335-2-51
Expected lifetime	> 100.000 h (with specified load profile) > 500.000 on/off cycles
Minimum switching time power on/off	With NTC: 1 minute With relay: No specific requirements
Reaction time - power on	With relay: < 2 seconds With NTC < 1 second
Reaction time - standby	With relay: < 2 seconds With NTC < 1 second
Reaction time - speed change	< 1 second
Inrush current	With NTC: < 10 A With relay: < 4 A
Maximum leakage current	≤ 3.5 mA (EN 60335-1)
Speed range	563 to 5991 min ⁻¹ (depending on the variant)
Relative humidity	Maximum 95 %, non-condensing environment
Standby power consumption	With relay < 1 W. With NTC < 1 W
Sleep mode power consumption	0.4 W
Surge robustness	With relay/NTC > 3 kV (DM/CM)
RF emissions	-6 dB CE / EN 55014-1,-2
Acoustic sound pressure level (LP)	≤ 32 dB(A) on cast iron housings
Maximum altitude of installation	2000 m above sea level

11. Performance curves and technical data

Curve conditions

The guidelines below apply to the performance curves:

- The test liquid is airless water.
- The curves apply to a density of 998.21 kg/m³ and a liquid temperature of 20 °C.
- All curves show average values and should not be used as guarantee curves. If a specific minimum performance is required, individual measurements must be made.
- The curves apply to a kinematic viscosity of 1.004 mm²/s (1.004 cSt).
- The conversion between head H [m] and pressure p [kPa] has been made for water with a density of 1000 kg/m³. For liquids with other densities, for example hot water, the outlet pressure is proportional to the density.
- Curves have been obtained according to EN 16297.
- Pump variants with PWM signal connection are designed to be speed controlled by an external system controller. Therefore, EEI and P_{L,Avg} of the different pump heads (pumps without pump housings) are measured to be in compliance with the Ecodesign requirements of regulation EC/622/2012 with a reference housing in accordance with EN 16297-3.
- It is not obligatory to show P_{L,Avg}, but it gives an indication on the yearly expectable average power consumption.
- The performance of PWM controlled pumps is measured with A profile (heating) at eight PWM values: 5 % (max.), 20 %, 31 %, 41 %, 52 %, 62 %, 73 %, 88 % (min.).
- C profile curves are measured mirrored with 95 % (max.), 80 %, 69 %, 59 %, 48 %, 38 %, 27 %, 12 % (min.).
- Maximum curves are limited by speed and power
- Variants with two different minimum curves are available: minimum curve A (standard) at approximately 0.1 m and minimum curve J (optional) at approximately 1 m.
- Other curves for different control signals or OEM housings are available on request.

Measured pump head variants

	UPM3S	Product mark	P ₁ max. nom. [W]	EEI Part 3	
		XX-40	GFNHB	-	≤ 0.20
PWM		XX-50	GFNHB	-	≤ 0.20
		XX-60	GFNHB	42	≤ 0.20
	LIN	XX-60	GFNHB	42	≤ 0.20
FLEX AS	XX-60	GFNHB	42	≤ 0.20	
AUTO	XX-60	GFNHB	42	≤ 0.20	
HYBRID	XX-60	GFNHB	42	≤ 0.20	

	UPM3	Product mark	P ₁ max. nom. [W]	EEI Part 3	
PWM		XX-50	GFNKB	33	≤ 0.20
		XX-60	GFNKB	39	≤ 0.20
		XX-70	GFNKB	52	≤ 0.20
		XX-75	GFNKB	60	≤ 0.20
LIN	XX-75	GFNKB	60	≤ 0.20	
FLEX AS		XX-50	GFNKB	33	≤ 0.20
		XX-70	GFNKB	52	≤ 0.20
		XX-75	GFNKB	60	≤ 0.20
AUTO		XX-50	GFNKB	33	≤ 0.20
		XX-70	GFNKB	52	≤ 0.20
SOLAR		XX-75	GFNKB	45	≤ 0.20
		XX-105	GFNKB	52	≤ 0.20
		XX-145	GFNKB	60	≤ 0.20
DHW		XX-20	GFNKB	11	≤ 0.20
		XX-50	GFNKB	33	≤ 0.20
		XX-70	GFNKB	52	≤ 0.20
HYBRID		XX-50	GFNKB	33	≤ 0.20
		XX-70	GFNKB	52	≤ 0.20

	UPM3L	Product mark	P ₁ max. nom. [W]	EEI Part 3
PWM	XX-75	GFNKC	75	≤ 0.20
LIN	XX-75	GFNKC	75	≤ 0.20
FLEX AS	XX-75	GFNKC	75	≤ 0.20
AUTO	XX-70	GFNKC	75	≤ 0.20
HYBRID	XX-70	GFNKC	75	≤ 0.20



	UPMO	Product mark	P ₁ max. nom. [W]	EEI Part 3
UPMO	XX-50	GFNKB	39	≤ 0.23
UPMO	XX-60	GFNKB	60	≤ 0.23
UPMO	XX-70	GFNKC	75	≤ 0.23

12. Accessories

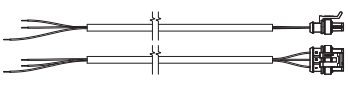
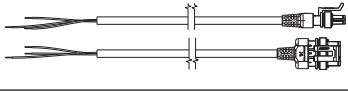
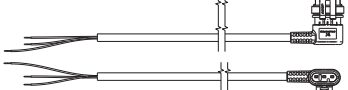
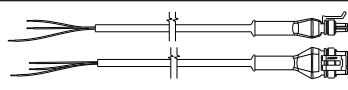
Power supply Superseal

Picture	Product description	Length [mm]	Product number	Pcs/box	Product number box
	Power supply cable, Superseal	1000	98460260	200	59200566
	Power supply cable, Superseal	2000	98373382	100	59200567
	Power supply cable, Superseal	4000	98460271	50	59200568
	Power supply Superseal, overmoulded	1000	98460258	200	59200569
	Power supply Superseal, overmoulded	2000	98373384	100	59200570
	Power supply Superseal, overmoulded	4000	98460259	50	59200571
	Power supply Superseal, overmoulded, angled 90°	1000	98616020	200	59200572
	Power supply Superseal, overmoulded, angled 90°	2000	98616051	100	59200535
	Power supply Superseal, with rubber cap	1000	98664474	200	98677544

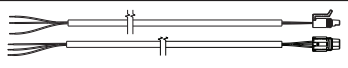
Signal cables

Picture	Product description	Length [mm]	Product number	Pcs/box	Product number box
	Signal cable Mini Superseal	1000	98460256	200	59200573
	Signal cable Mini Superseal	2000	98347385	100	59200574
	Signal cable, FCI, 3 wire, with return signal	1000	96645398	100	59200576
	Signal cable, FCI, 3 wire, with return signal	2000	97940991	100	59200578
	Signal cable, FCI, 2 wire, without return signal	1000	98386202	200	59200575
	Signal cable, FCI, 2 wire, without return signal	2000	97698929	200	59200577

Power cable adapters

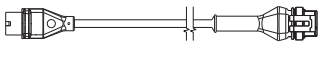
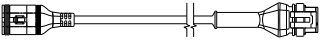
Picture	Product description	Length [mm]	Product number	Pcs/box	Product number box
	Superseal Molex cable adapter, overmoulded, with rubber cap	150	98614629	100	59200661
	Superseal Volex cable adapter, overmoulded, with rubber cap	150	98614444	100	59200633

Plugs

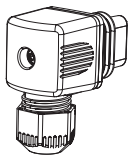
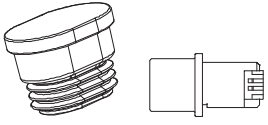
Picture	Product description	Length [mm]	Product number	Pcs/box	Product number box
	Superseal installation plug	-	99436122	100	99171101
	Signal blind plug, FCI	-	97823485	100	59200643
	Signal blind plug, Mini Superseal	-	98451691	100	59200639
	Signal blind plug, Mini Superseal	-	98451691	500	59200640

Gaskets

Gasket material	Pump connection	External diameter (D) [mm]	Internal diameter (d) [mm]	Thickness (s) [mm]	Product number
EDPM	G 1	29.5	21	2	504023
EDPM	G 1 1/2	44	32	2	520046
K for drinking water use	G 1 1/2	44	32	2	520226
EDPM	G 2	56	40	2	530243
K for drinking water use	G 2	56	40	2	530086

Related information

[Pump housing overview](#)

Insulation kits

Insulation kits for warm water applications are available on request. These insulation kits contain two insulation shells. The thickness of the insulation shells corresponds to the nominal diameter of the pump. The insulation kit is tailor-made for the individual pump type and encloses the entire pump housing. Both insulation shells are easy to fit around the pump.

Description	Product number
Insulation shells for UPM3/4 (1 kit)	98803317
Insulation shells for UPM3/4 (50 kits)	59200662

Diffusion-tight insulation shells for condensing applications are not available.

Quick guides, UPM3

Quick guides for different UPM3 variants are available on request.

Description	Product number
UPM3(K)	
UPM3(K) FLEX AS	
UPM3(K) DHW	
UPM3(K) SOLAR	99995301
UPM3(K) AUTO	
UPM3(K) HYBRID	
UPMO	99754368
Pump head	99753819

Pins, clips, O-rings

Pins, clips, O-rings for the different composite housings are available on request.

ALPHA Reader



TM068574

ALPHA Reader is the receiver and transmitter of pump performance data. The unit uses a CR2032 lithium battery. The unit, together with the Grundfos GO Balance app, is used for balancing heating systems.

Description	Product number
ALPHA Reader MI401	98916967

13. Data sheets

UPM3S XX-40 130/180 (N) (GFNHB)

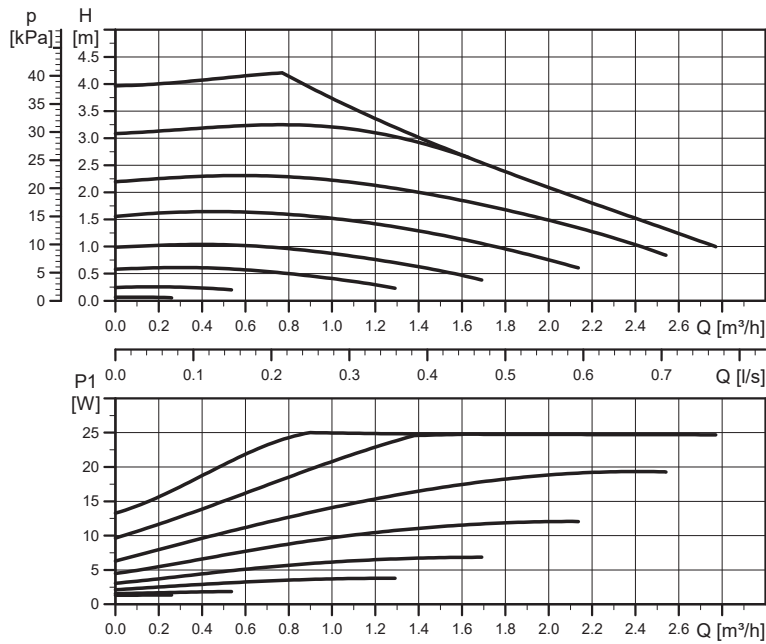

TM068617

EEI ≤ 0.20 Part 3

$P_{L,avg} \leq 12 \text{ W}$

Pump settings			
1 factory preset			
Electrical data, 1 x 230 V, 50 Hz			
Speed	P_1 [W]	$I_{1/1}$ [A]	
Min.	2	0.04	
Max.	25	0.29	
Technical data			
System pressure	Max. 1.0 MPa (10 bar)	Enclosure class	IP44 (non-condensing)
Minimum inlet pressure	0.05 MPa (0.50 bar) at 95 °C liquid temperature	Motor protection	No external protection needed
Liquid temperature	2-110 °C (TF110)	Approval and marking	VDE, CE

Dimensions

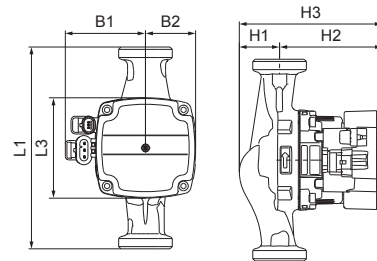

TM063878

Pump type	Dimensions [mm]							Connections [inch]	Weight [kg]
	L1	L3	B1	B2	H1	H2	H3		
15-40 130 (N)	130	90	72	45	36	92	128	R 1/2 / G 1	1.8
25-40 130 (N)	130	90	72	45	36	92	128	R 1 / G 1 1/2	1.9
25-40 180 (N)	180	90	72	45	36	92	128	R 1 / G 1 1/2	2.0
32-40 130 (N)	180	90	72	45	36	92	128	R 1 1/4 / G 2	2.2

UPM3S XX-50 130/180 (N) (GFNHB)

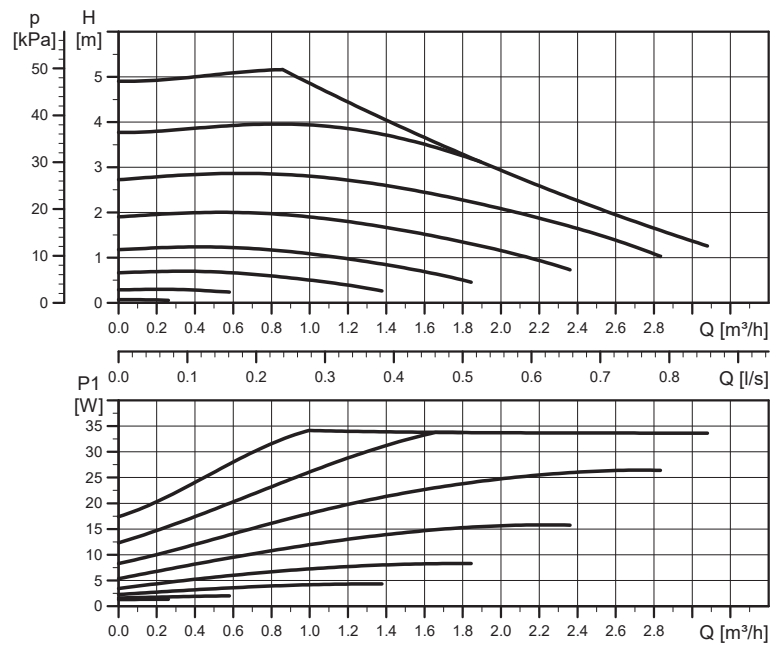

TM068618

EEI ≤ 0.20 Part 3

P_{L,avg} ≤ 16 W

Pump settings			
1 factory preset			
Electrical data, 1 x 230 V, 50 Hz			
Speed	P ₁ [W]	I _{1/1} [A]	
Min.	2	0.04	
Max.	34	0.36	
Technical data			
System pressure	Max. 1.0 MPa (10 bar)	Enclosure class	IP44 (non-condensing)
Minimum inlet pressure	0.05 MPa (0.50 bar) at 95 °C liquid temperature	Motor protection	No external protection needed
Liquid temperature	2-110 °C (TF110)	Approval and marking	VDE, CE

Dimensions

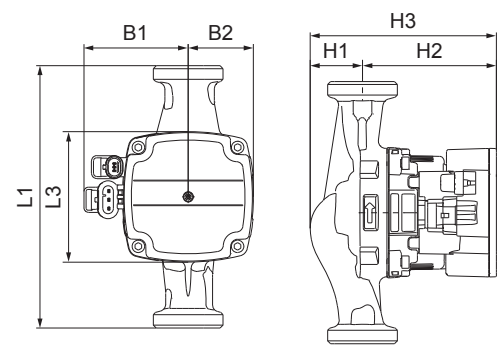

TM063878

Pump type	Dimensions [mm]							Connections [inch]	Weight [kg]
	L1	L3	B1	B2	H1	H2	H3		
15-50 130 (N)	130	90	72	45	36	92	128	R 1/2 / G 1	1.8
25-50 130 (N)	130	90	72	45	36	92	128	R 1 / G 1 1/2	1.9
25-50 180 (N)	180	90	72	45	36	92	128	R 1 / G 1 1/2	2.0
32-50 180 (N)	180	90	72	45	36	92	128	R 1 1/4 / G 2	2.2

UPM3S XX-60 130/180 (N) (GFNHB)

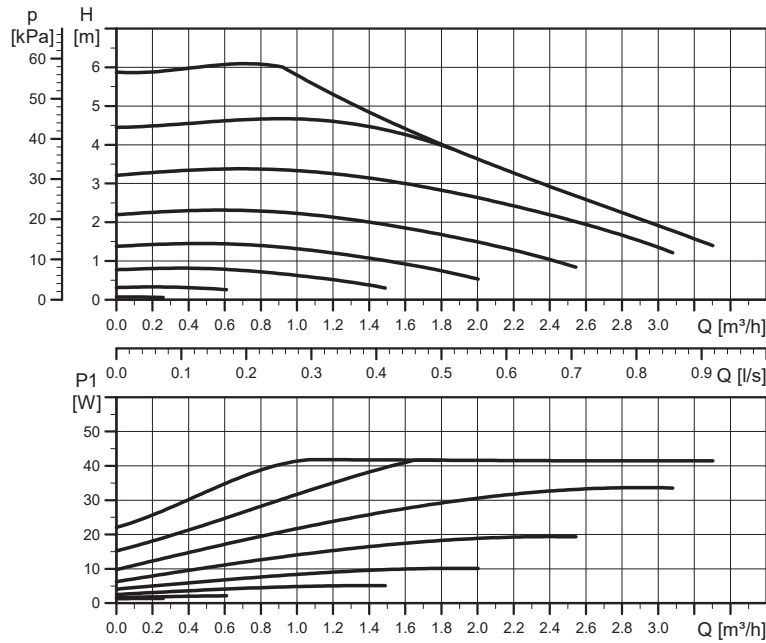

TM068619

EEI ≤ 0.20 Part 3

$P_{L,avg} \leq 20 \text{ W}$

Pump settings			
1 factory preset			
Electrical data, 1 x 230 V, 50 Hz			
Speed	P_1 [W]	$I_{1/1}$ [A]	
Min.	2	0.04	
Max.	42	0.40	
Technical data			
System pressure	Max. 1.0 MPa (10 bar)	Enclosure class	IP44 (non-condensing)
Minimum inlet pressure	0.05 MPa (0.50 bar) at 95 °C liquid temperature	Motor protection	No external protection needed
Liquid temperature	2-110 °C (TF110)	Approval and marking	VDE, CE

Dimensions

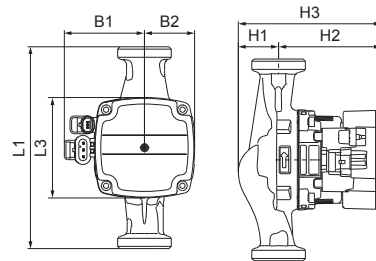

TM063878

Pump type	Dimensions [mm]							Connections [inch]	Weight [kg]
	L1	L3	B1	B2	H1	H2	H3		
15-60 130 (N)	130	90	72	45	36	92	128	R 1/2 / G 1	1.8
25-60 130 (N)	130	90	72	45	36	92	128	R 1 / G 1 1/2	1.9
25-60 180 (N)	180	90	72	45	36	92	128	R 1 / G 1 1/2	2.0
32-60 180 (N)	180	90	72	45	36	92	128	R 1 1/4 / G 2	2.2

UPM3S FLEX AS XX-60 130/180 (N) (GFNHB)

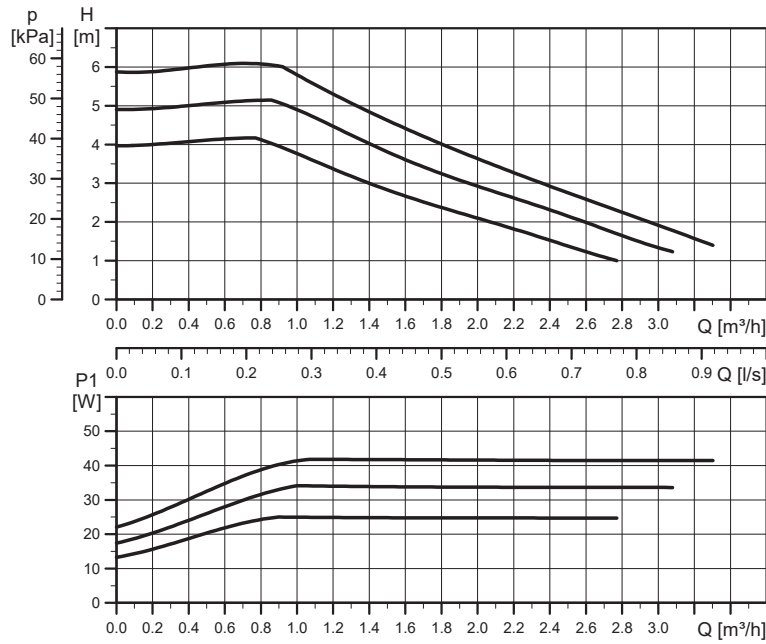

TM068625

EEI ≤ 0.20 Part 3

P_{L,avg} ≤ 20 W

Setting	Max. head _{nom}	Max. P ₁ _{nom}
Curve 1	4 m	25 W
Curve 2	5 m	34 W
Curve 3	6 m	42 W

Pump settings				
PWM A	PWM C	PP	CP	CC
3	-	-	-	-

Electrical data, 1 x 230 V, 50 Hz		
Speed	P ₁ [W]	I _{1/1} [A]
Min.	2	0.04
Max.	42	0.40

Technical data			
System pressure	Max. 1.0 MPa (10 bar)	Enclosure class	IP44 (non-condensing)
Minimum inlet pressure	0.05 MPa (0.50 bar) at 95 °C liquid temperature	Motor protection	No external protection needed
Liquid temperature	2-110 °C (TF110)	Approval and marking	VDE, CE

Dimensions

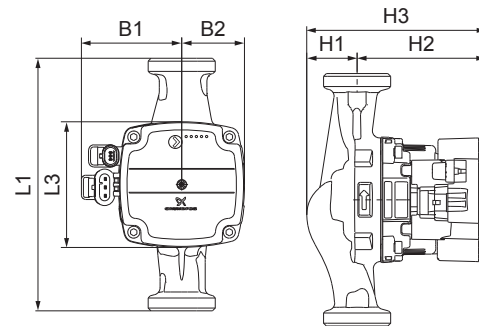

TM063879

Pump type	Dimensions [mm]							Connections [inch]	Weight [kg]
	L1	L3	B1	B2	H1	H2	H3		
15-60 130 (N)	130	90	72	45	36	92	128	R 1/2 / G 1	1.8
25-60 130 (N)	130	90	72	45	36	92	128	R 1 / G 1 1/2	1.9
25-60 180 (N)	180	90	72	45	36	92	128	R 1 / G 1 1/2	2.0
32-60 180 (N)	180	90	72	45	36	92	128	R 1 1/4 / G 2	2.2

For PWM speed curves, see [13.3 UPM3S XX-60 130/180 \(N\) \(GFNHB\)](#).

UPM3S AUTO XX-60 130/180 (N)

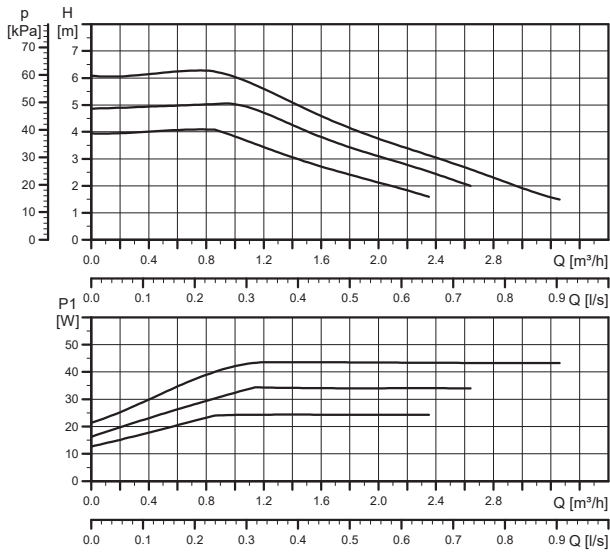

Line type	Description
—————	Constant curve
-----	Proportional pressure
.....	Constant pressure

EEI ≤ 0.23 Part 3
 P_{L,avg} ≤ 16 W

Setting	Max. head _{nom}	Max. P _{1 nom}
Curve 1	4 m	25 W
Curve 2	5 m	33 W
Curve 3	6 m	39 W

Pump settings

PWM A	PWM C	PP	CP	CC
-	-	3/AA	3/AA	3

Electrical data, 1 x 230 V, 50 Hz

Speed	P ₁ [W]	I _{1/1} [A]
Min.	2	0.04
Max.	39	0.40

Technical data

System pressure	Max. 1.0 MPa (10 bar)	Enclosure class	IP44 (non-condensing) K: IPX4D (condensing)
Minimum inlet pressure	0.05 MPa (0.50 bar) at 95 °C liquid temperature	Motor protection	No external protection needed
Liquid temperature	2-110 °C (TF110)	Approval and marking	VDE, CE

Dimensions

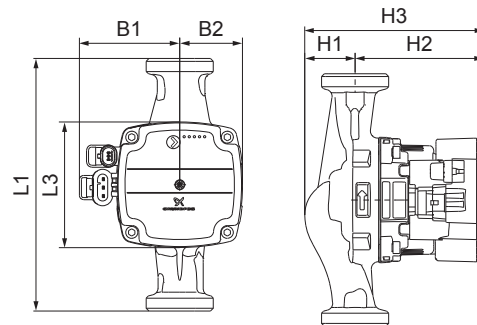

TM063879

Dimensions

Pump type	Dimensions [mm]							Connections [inch]	Weight [kg]
	L1	L3	B1	B2	H1	H2	H3		
15-60 130 (N)	130	90	72	45	36	92	128	R 1/2 / G 1	1.8
25-60 130 (N)	130	90	72	45	36	92	128	R 1 / G 1 1/2	1.9
25-60 180 (N)	180	90	72	45	36	92	128	R 1 / G 1 1/2	2.0
32-60 180 (N)	180	90	72	45	36	92	128	R 1 1/4 / G 2	2.2

UPM3(K) XX-50 130/180 (N) (GFNKB)

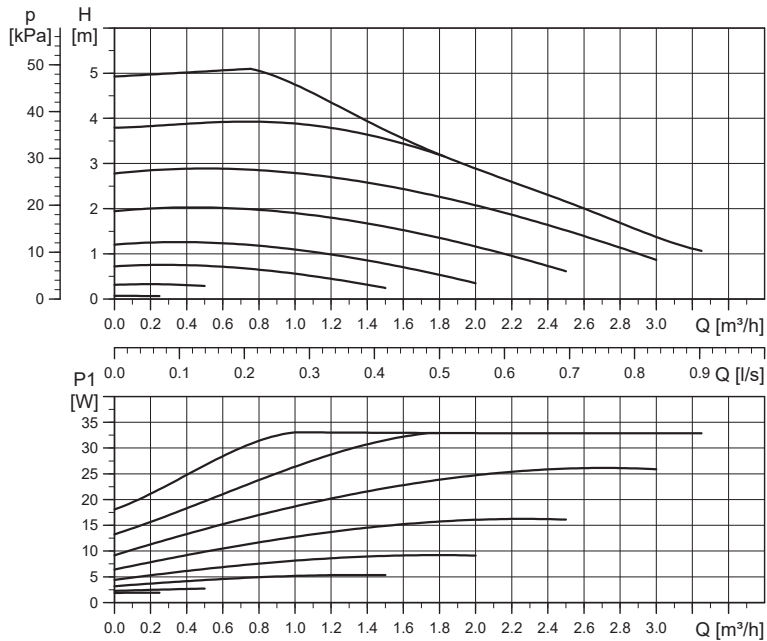

TM060577

EEl: ≤ 0.20 Part 3
 PL,avg ≤ 16 W

Pump settings				
1 factory preset				
Electrical data, 1 x 230 V, 50 Hz				
Speed	P ₁ [W]		I _{1/1} [A]	
	Low min. speed	High min. speed	Low min. speed	High min. speed
Min.	2	4	0.04	0.05
Max.	33		0.36	
Technical data				
System pressure	Max. 1.0 MPa (10 bar)	Enclosure class	IP44 (non-condensing) K: IPX4D (condensing)	
Minimum inlet pressure	0.05 MPa (0.50 bar) at 95 °C liquid temperature	Motor protection	No external protection needed	
Liquid temperature	2-110 °C (TF110)	Approval and marking	VDE, CE	

Dimensions

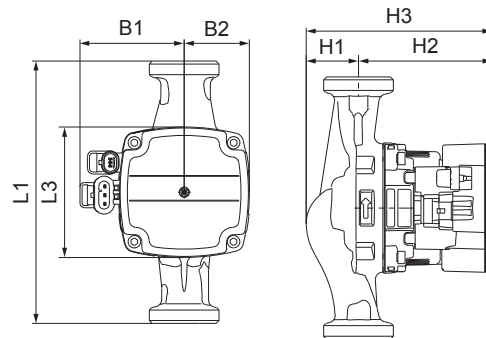

TM063878

Pump type	Dimensions [mm]							Connections [inch]	Weight [kg]
	L1	L3	B1	B2	H1	H2	H3		
15-50 130 (N)	130	90	72	45	36	92	128	R 1/2 / G 1	1.8
25-50 130 (N)	130	90	72	45	36	92	128	R 1 / G 1 1/2	1.9
25-50 180 (N)	180	90	72	45	36	92	128	R 1 / G 1 1/2	2.0
32-50 180 (N)	180	90	72	45	36	92	128	R 1 1/4 / G 2	2.2

UPM3(K) XX-60 130/180 (N) (GFNKB)

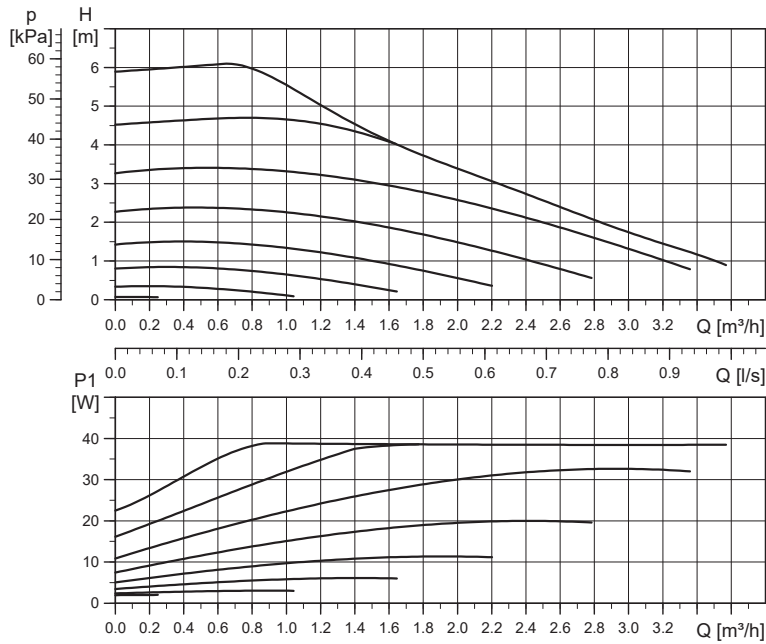

TM060578

EEl: ≤ 0.20 Part 3
 PL,avg ≤ 18 W

Pump settings			
1 factory preset			
Electrical data, 1 x 230 V, 50 Hz			
Speed	P ₁ [W]		I _{1/1} [A]
	Low min. speed	High min. speed	
Min.	2	4	0.04 0.05
Max.	39		0.42
Technical data			
System pressure	Max. 1.0 MPa (10 bar)	Enclosure class	IP44 (non-condensing) K: IPX4D (condensing)
Minimum inlet pressure	0.05 MPa (0.50 bar) at 95 °C liquid temperature	Motor protection	No external protection needed
Liquid temperature	2-110 °C (TF110)	Approval and marking	VDE, CE

Dimensions

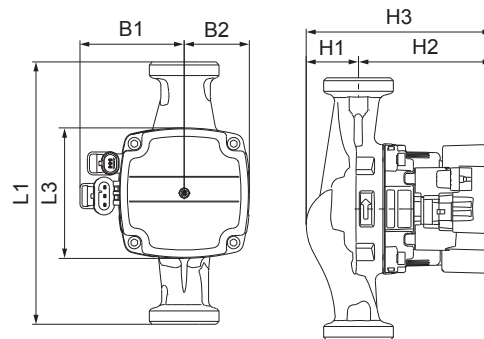

TM063878

Pump type	Dimensions [mm]							Connections [inch]	Weight [kg]
	L1	L3	B1	B2	H1	H2	H3		
15-60 130 (N)	130	90	72	45	36	92	128	R 1/2 / G 1	1.8
25-60 130 (N)	130	90	72	45	36	92	128	R 1 / G 1 1/2	1.9
25-60 180 (N)	180	90	72	45	36	92	128	R 1 / G 1 1/2	2.0
32-60 180 (N)	180	90	72	45	36	92	128	R 1 1/4 / G 2	2.2

UPM3(K) XX-70 130/180 (N) (GFNKB)

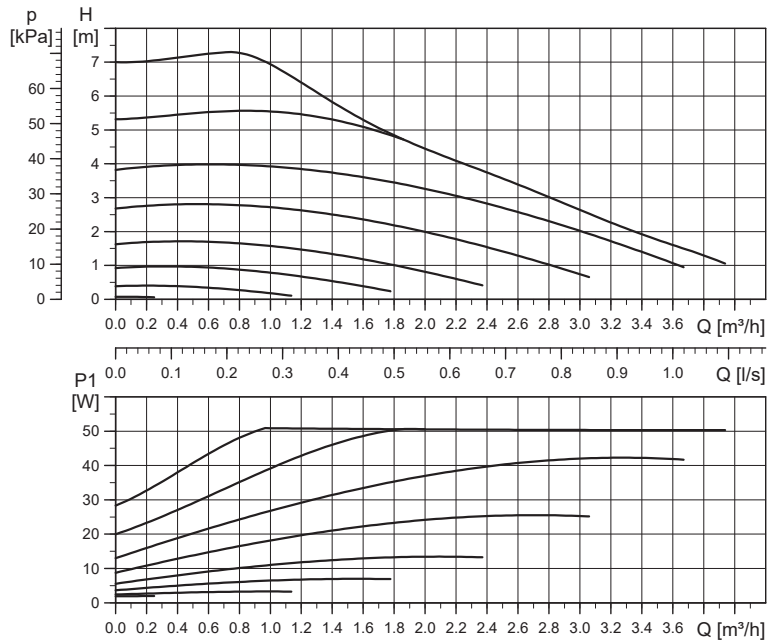

TM060579

EEL: ≤ 0.20 Part 3
 PL,avg ≤ 23 W

Pump settings			
1 factory preset			
Electrical data, 1 x 230 V, 50 Hz			
Speed	P ₁ [W]		I _{1/1} [A]
	Low min. speed	High min. speed	
Min.	2	4	0.04 0.05
Max.	52		0.52
Technical data			
System pressure	Max. 1.0 MPa (10 bar)	Enclosure class	IP44 (non-condensing) K: IPX4D (condensing)
Minimum inlet pressure	0.05 MPa (0.50 bar) at 95 °C liquid temperature	Motor protection	No external protection needed
Liquid temperature	2-110 °C (TF110)	Approval and marking	VDE, CE

Dimensions

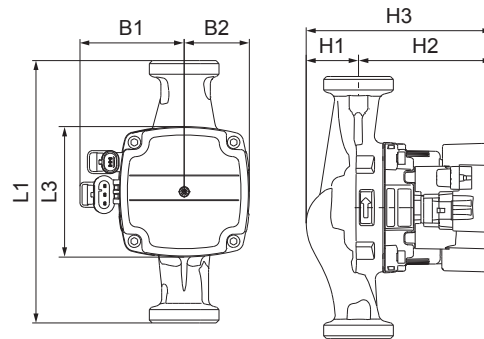

TM063878

Pump type	Dimensions [mm]							Connections [inch]	Weight [kg]
	L1	L3	B1	B2	H1	H2	H3		
15-70 130 (N)	130	90	72	45	36	92	128	R 1/2 / G 1	1.8
25-70 130 (N)	130	90	72	45	36	92	128	R 1 / G 1 1/2	1.9
25-70 180 (N)	180	90	72	45	36	92	128	R 1 / G 1 1/2	2.0
32-70 180 (N)	180	90	72	45	36	92	128	R 1 1/4 / G 2	2.2

UPM3(K) XX-75 130/180 (N) (GFNKB)

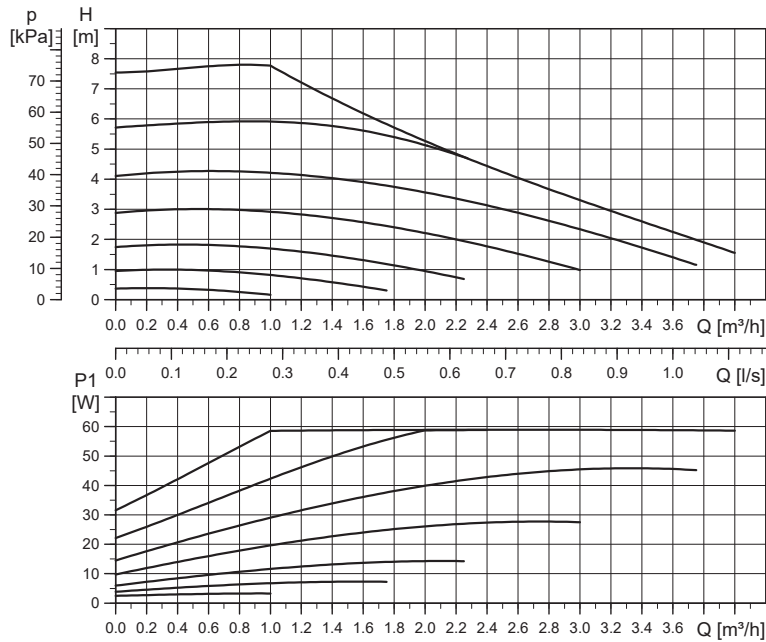

TM060580

EEL: ≤ 0.20 Part 3
 PL,avg ≤ 28 W

Pump settings				
1 factory preset				
Electrical data, 1 x 230 V, 50 Hz				
Speed	P ₁ [W]		I _{1/1} [A]	
	Low min. speed	High min. speed	Low min. speed	High min. speed
Min.	2	4	0.04	0.05
Max.	60		0.58	
Technical data				
System pressure	Max. 1.0 MPa (10 bar)	Enclosure class	IP44 (non-condensing) K: IPX4D (condensing)	
Minimum inlet pressure	0.05 MPa (0.50 bar) at 95 °C liquid temperature	Motor protection	No external protection needed	
Liquid temperature	2-110 °C (TF110)	Approval and marking	VDE, CE	

Dimensions

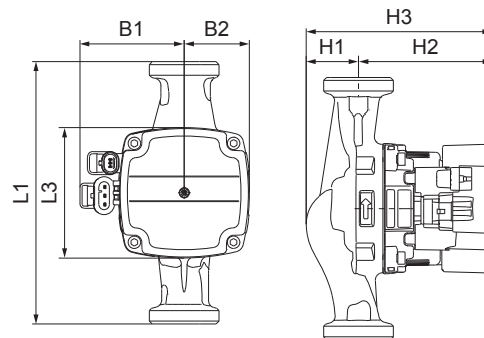

TM063878

Pump type	Dimensions [mm]							Connections [inch]	Weight [kg]
	L1	L3	B1	B2	H1	H2	H3		
15-75 130 (N)	130	90	72	45	36	92	128	R 1/2 / G 1	1.8
25-75 130 (N)	130	90	72	45	36	92	128	R 1 / G 1 1/2	1.9
25-75 180 (N)	180	90	72	45	36	92	128	R 1 / G 1 1/2	2.0
32-75 180 (N)	180	90	72	45	36	92	128	R 1 1/4 / G 2	2.0

UPM3(K) FLEX AS XX-50 130/180 (N) (GFNKB)

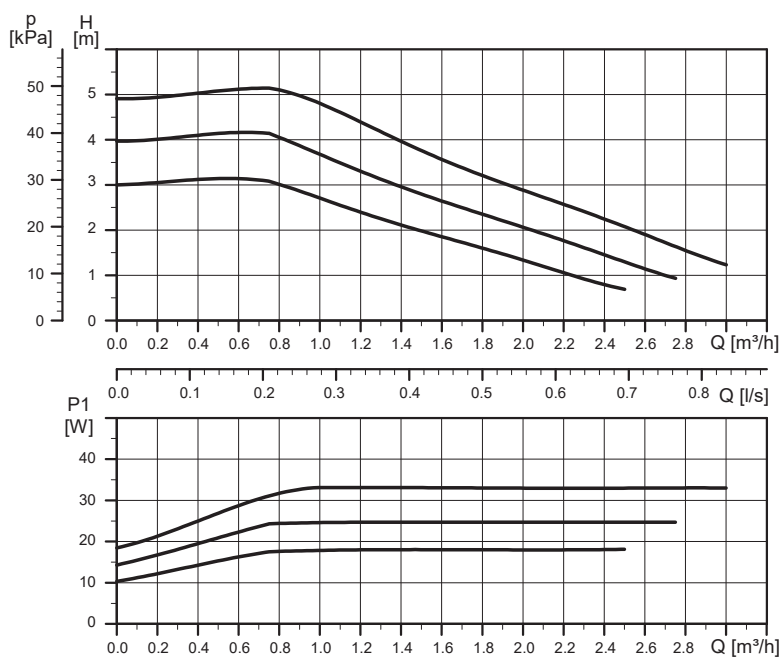

TM064090

EEI ≤ 0.20 Part 3

$P_{L,avg} \leq 16 \text{ W}$

Setting	Max. head _{nom}	Max. P ₁ nom
Curve 1	3 m	18 W
Curve 2	4 m	25 W
Curve 3	5 m	33 W

Pump settings				
PWM A	PWM C	PP	CP	CC
3	-	-	-	-

Electrical data, 1 x 230 V, 50 Hz				
Speed	P ₁ [W]		I _{1/1} [A]	
	Low min. speed	High min. speed	Low min. speed	High min. speed
Min.	2	4	0.04	0.05
Max.	33		0.36	

Technical data			
System pressure	Max. 1.0 MPa (10 bar)	Enclosure class	IP44 (non-condensing) K: IPX4D (condensing)
Minimum inlet pressure	0.05 MPa (0.50 bar) at 95 °C liquid temperature	Motor protection	No external protection needed
Liquid temperature	+2 °C to +110 °C (TF110)	Approval and marking	VDE, CE

Dimensions

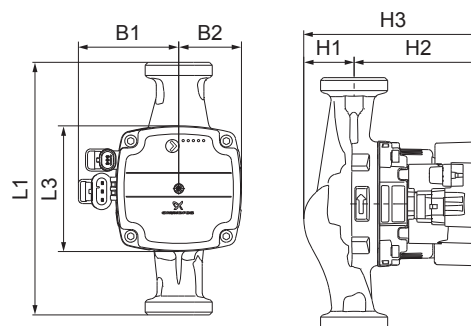

TM063879

Pump type	Dimensions [mm]							Connections [inch]	Weight [kg]
	L1	L3	B1	B2	H1	H2	H3		
15-50 130 (N)	130	90	72	45	36	92	128	R 1/2 / G 1	1.8
25-50 130 (N)	130	90	72	45	36	92	128	R 1 / G 1 1/2	1.9
25-50 180 (N)	180	90	72	45	36	92	128	R 1 / G 1 1/2	2.0
32-50 180 (N)	180	90	72	45	36	92	128	R 1 1/4 / G 2	2.2

For PWM speed curves, see [13.6 UPM3\(K\) XX-50 130/180 \(N\) \(GFNKB\)](#).

UPM3(K) FLEX AS XX-70 130/180 (N) (GFNKB)

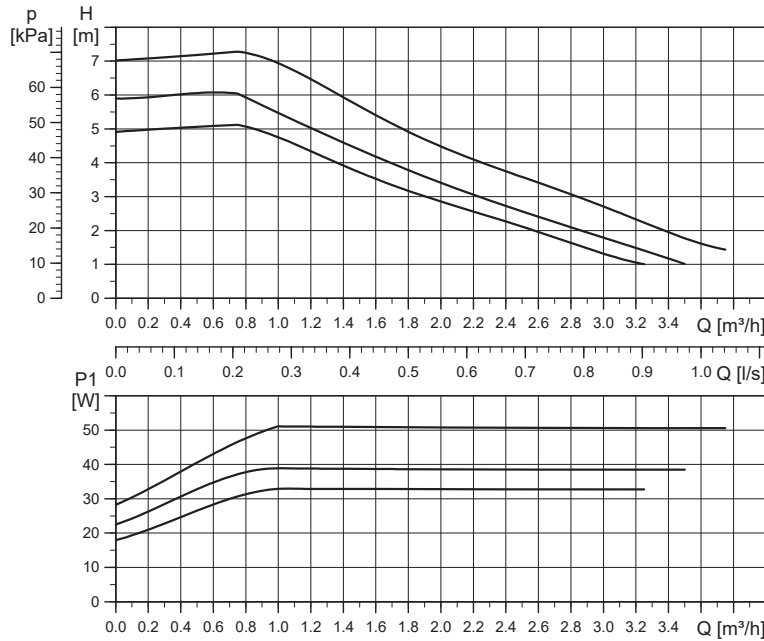

TM060584

EEI ≤ 0.20 Part 3

P_{L,avg} ≤ 23 W

Setting	Max. head _{nom}	Max. P _{1 nom}
Curve 1	5 m	33 W
Curve 2	6 m	39 W
Curve 3	7 m	52 W

Pump settings				
PWM A	PWM C	PP	CP	CC
3	-	-	-	-

Electrical data, 1 x 230 V, 50 Hz				
Speed	P ₁ [W]		I _{1/1} [A]	
	Low min. speed	High min. speed	Low min. speed	High min. speed
Min.	2	4	0.04	0.05
Max.	52		0.52	

Technical data			
System pressure	Max. 1.0 MPa (10 bar)	Enclosure class	IP44 (non-condensing) K: IPX4D (condensing)
Minimum inlet pressure	0.05 MPa (0.50 bar) at 95 °C liquid temperature	Motor protection	No external protection needed
Liquid temperature	+2 °C to +110 °C (TF110)	Approval and marking	VDE, CE

Dimensions

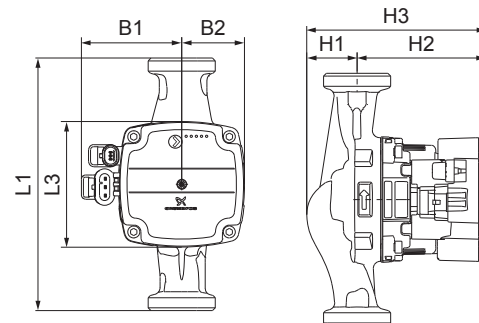

TM063879

Pump type	Dimensions [mm]							Connections [inch]	Weight [kg]
	L1	L3	B1	B2	H1	H2	H3		
15-70 130 (N)	130	90	72	45	36	92	128	R 1/2 / G 1	1.8
25-70 130 (N)	130	90	72	45	36	92	128	R 1 / G 1 1/2	1.9
25-70 180 (N)	180	90	72	45	36	92	128	R 1 / G 1 1/2	2.0
32-70 180 (N)	180	90	72	45	36	92	128	R 1 1/4 / G 2	2.2

For PWM speed curves, see 13.8 UPM3(K) XX-70 130/180 (N) (GFNKB).

UPM3(K) FLEX AS XX-75 130/180 (N) (GFNKB)

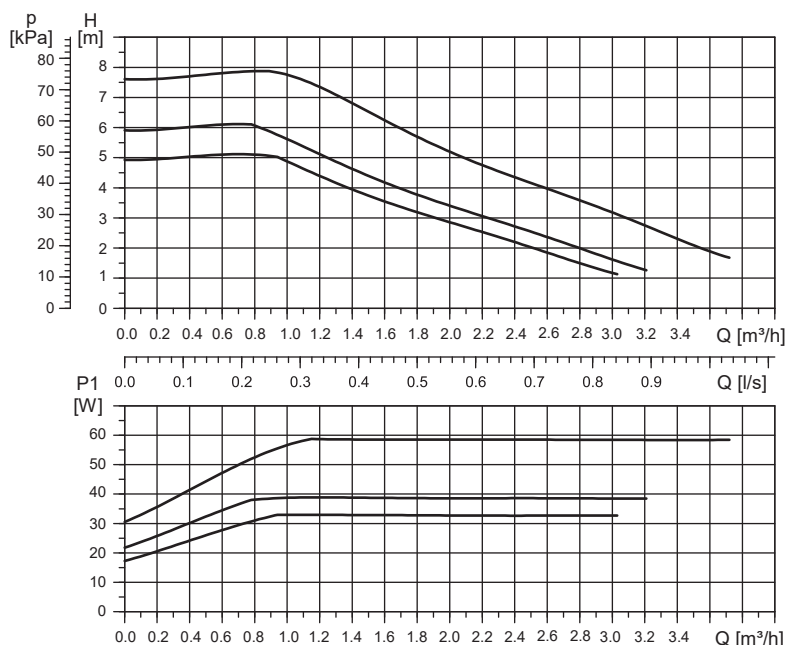

TM063872

EEI ≤ 0.20 Part 3

$P_{L,avg} \leq 28 \text{ W}$

Setting	Max. head H_{nom}	Max. P_1 $P_{1, nom}$
Curve 1	5 m	33 W
Curve 2	6 m	39 W
Curve 3	7.5 m	60 W

Pump settings				
PWM A	PWM C	PP	CP	CC
3	-	-	-	-

Electrical data, 1 x 230 V, 50 Hz				
Speed	P_1 [W]		$I_{1/1}$ [A]	
	Low min. speed	High min. speed	Low min. speed	High min. speed
Min.	2	4	0.04	0.05
Max.	60		0.58	

Technical data			
System pressure	Max. 1.0 MPa (10 bar)	Enclosure class	IP44 (non-condensing) K: IPX4D (condensing)
Minimum inlet pressure	0.05 MPa (0.50 bar) at 95 °C liquid temperature	Motor protection	No external protection needed
Liquid temperature	+2 °C to +110 °C (TF110)	Approval and marking	VDE, CE

Dimensions

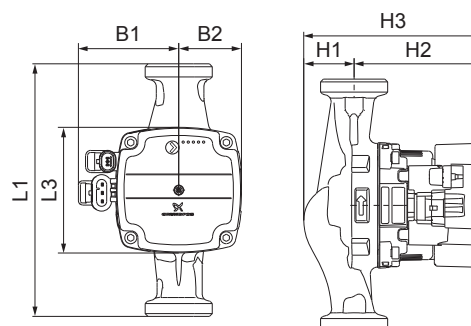

TM063879

Pump type	Dimensions [mm]							Connections [inch]	Weight [kg]
	L1	L3	B1	B2	H1	H2	H3		
15-75 130 (N)	130	90	72	45	36	92	128	R 1/2 / G 1	1.8
25-75 130 (N)	130	90	72	45	36	92	128	R 1 / G 1 1/2	1.9
25-75 180 (N)	180	90	72	45	36	92	128	R 1 / G 1 1/2	2.0
32-75 180 (N)	180	90	72	45	36	92	128	R 1 1/4 / G 2	2.0

For PWM speed curves, see [13.9 UPM3\(K\) XX-75 130/180 \(N\) \(GFNKB\)](#).

**UPM3(K) FLEX AS 15-75 CIL3
(GFNKB)**

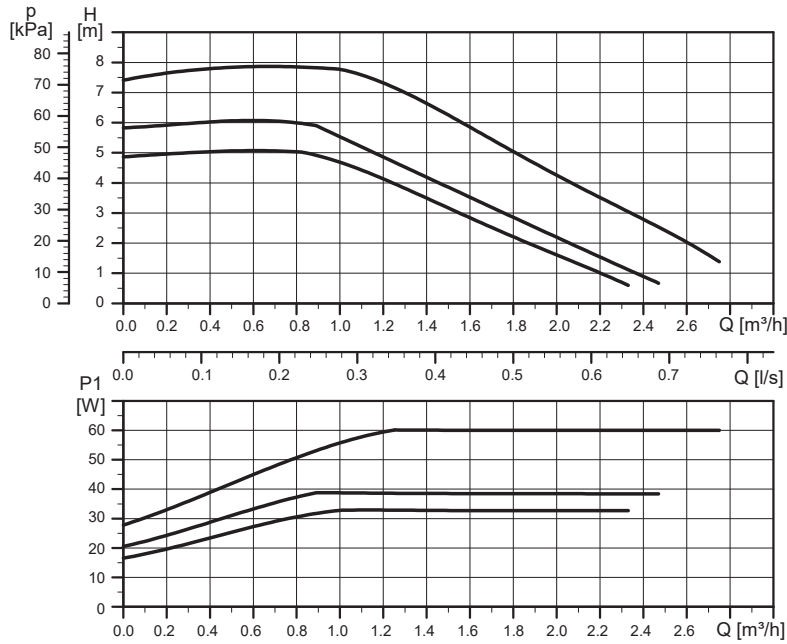

TM063869

EEI ≤ 0.20 Part 3

$P_{L,avg} \leq 28 \text{ W}$

Setting	Max. head _{nom}	Max. P ₁ _{nom}
Curve 1	5 m	33 W
Curve 2	6 m	39 W
Curve 3	7.5 m	60 W

Pump settings				
PWM A	PWM C	PP	CP	CC
3	-	-	-	-

Electrical data, 1 x 230 V, 50 Hz				
Speed	P ₁ [W]		I _{1/1} [A]	
	Low min. speed	High min. speed	Low min. speed	High min. speed
Min.	2	4	0.04	0.05
Max.	60		0.58	

Technical data			
System pressure	PA 6.6: Max. 0.3 MPa (3 bar) PPS: Max. 1.0 MPa (10 bar)	Enclosure class	IP44 (non-condensing) K: IPX4D (condensing)
Minimum inlet pressure	0.05 MPa (0.50 bar) at 95 °C liquid temperature	Motor protection	No external protection needed
Liquid temperature	2-95 °C (TF95)	Approval and marking	VDE, CE

Dimensions

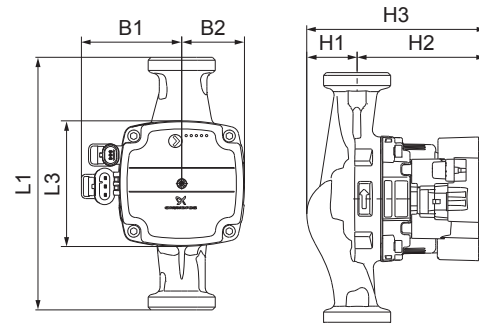

TM063879

Pump type	Dimensions [mm]							Connections [inch]	Weight [kg]
	L1	L3	B1	B2	H1	H2	H3		
15-75 CIL3	130	90	72	45	28	96	124	R 1/2 / G 1	1.3

PWM speed curves on request.

UPM3(K) FLEX AS 15-75 GGES3 (GFNKB)

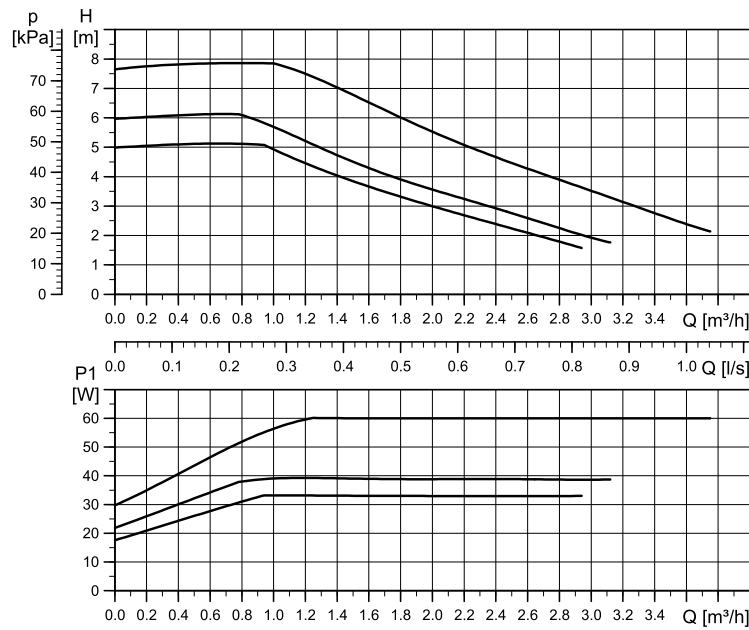

TM063870

EEI ≤ 0.20 Part 3
 P_{L,avg} ≤ 28 W

Setting	Max. head nom	Max. P ₁ nom
Curve 1	5 m	33 W
Curve 2	6 m	39 W
Curve 3	7.5 m	60 W

Pump settings				
PWM A	PWM C	PP	CP	CC
3	-	-	-	-

Electrical data, 1 x 230 V, 50 Hz				
Speed	P ₁ [W]		I _{1/1} [A]	
	Low min. speed	High min. speed	Low min. speed	High min. speed
Min.	2	4	0.04	0.05
Max.	60		0.58	

Technical data			
System pressure	Max. 1.0 MPa (10 bar)	Enclosure class	IP44 (non-condensing) K: IPX4D (condensing)
Minimum inlet pressure	0.05 MPa (0.50 bar) at 95 °C liquid temperature	Motor protection	No external protection needed
Liquid temperature	2-110 °C (TF110)	Approval and marking	VDE, CE

Dimensions

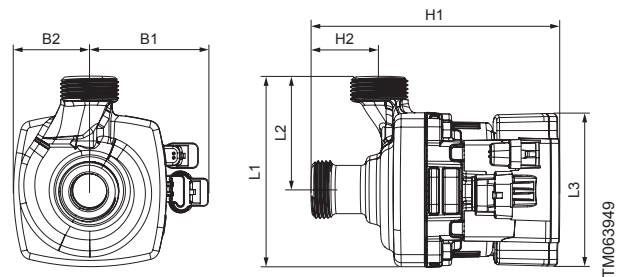

TM063949

Pump type	Dimensions [mm]							Connections [inch]	Weight [kg]
	L1	L3	B1	B2	H1	H2	H3		
15-75 GGES3	110	65	90	72	47	141	39	R 1/2 / G 1	2.0

PWM speed curves on request.

UPM3(K) FLEX AS 15-75 GGMBP3 (GFNKB)

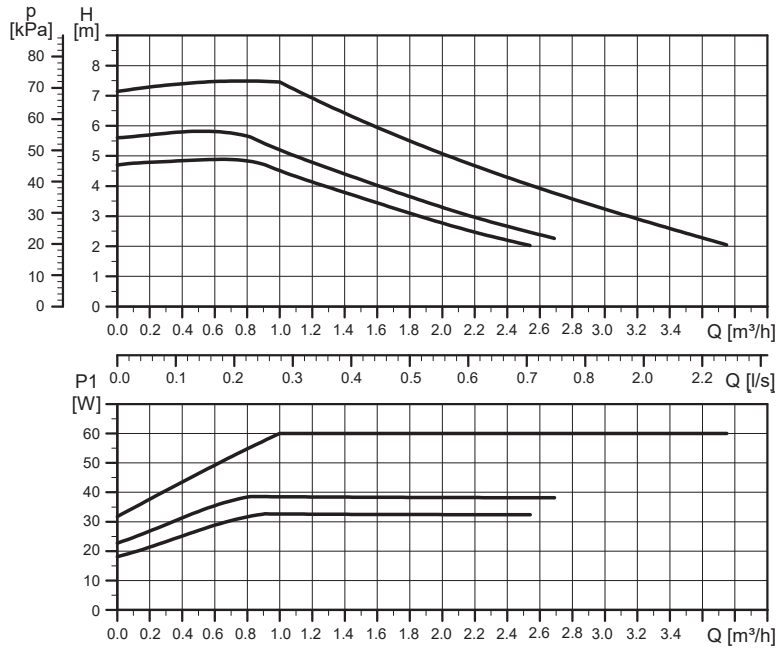

TM064091

EEI ≤ 0.20 Part 3
 P_{L,avg} ≤ 28 W

Setting	Max. head _{nom}	Max. P ₁ nom
Curve 1	5 m	33 W
Curve 2	6 m	39 W
Curve 3	7.5 m	60 W

Pump settings				
PWM A	PWM C	PP	CP	CC
3	-	-	-	-

Electrical data, 1 x 230 V, 50 Hz				
Speed	P ₁ [W]		I _{1/1} [A]	
	Low min. speed	High min. speed	Low min. speed	High min. speed
Min.	2	4	0.04	0.05
Max.	60		0.58	

Technical data			
System pressure	Max. 1.0 MPa (10 bar)	Enclosure class	IP44 (non-condensing) K: IPX4D (condensing)
Minimum inlet pressure	0.05 MPa (0.50 bar) at 95 °C liquid temperature	Motor protection	No external protection needed
Liquid temperature	2-110 °C (TF110)	Approval and marking	VDE, CE

Dimensions

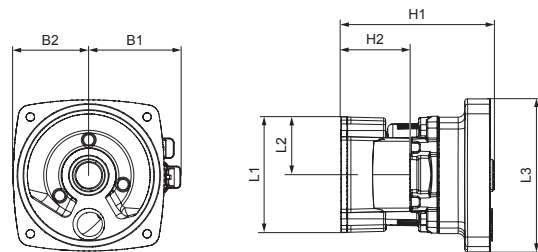

TM063959

Pump type	Dimensions [mm]							Connections [inch]	Weight [kg]
	L1	L3	B1	B2	H1	H2	H3		
15-75 GGMBP3	93	46.5	90	72	47	114	48.5	19/26	2.2

PWM speed curves on request.

UPM3(K) FLEX AS 15-75 GGBP3 (GFNKB)

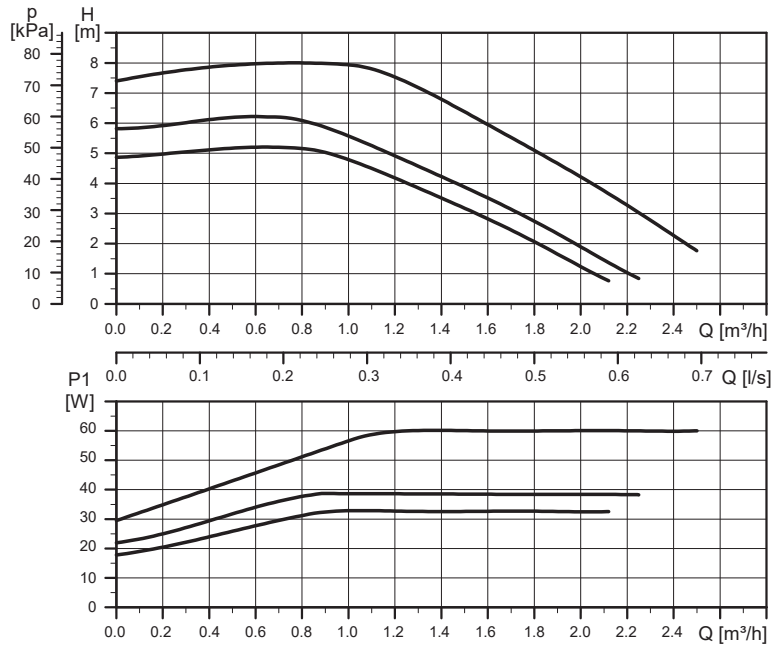

TM063871

EEI ≤ 0.20 Part 3

PL,avg ≤ 28 W

Setting	Max. head _{nom}	Max. P _{1 nom}
Curve 1	5 m	33 W
Curve 2	6 m	39 W
Curve 3	7.5 m	60 W

Pump settings				
PWM A	PWM C	PP	CP	CC
4	-	-	-	-

Electrical data, 1 x 230 V, 50 Hz				
Speed	P ₁ [W]		I _{1/1} [A]	
	Low min. speed	High min. speed	Low min. speed	High min. speed
Min.	2	4	0.04	0.05
Max.	60		0.58	

Technical data			
System pressure	Max. 1.0 MPa (10 bar)	Enclosure class	IP44 (non-condensing) K: IPX4D (condensing)
Minimum inlet pressure	0.05 MPa (0.50 bar) at 95 °C liquid temperature	Motor protection	No external protection needed
Liquid temperature	2-110 °C (TF110)	Approval and marking	VDE, CE

Dimensions

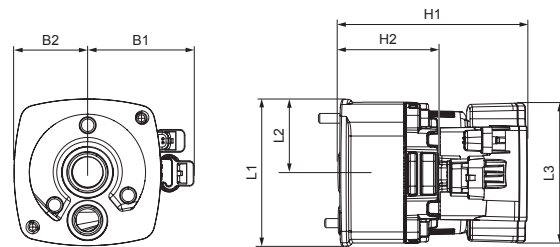

TM063958

Pump type	Dimensions [mm]							Connections [inch]	Weight [kg]
	L1	L3	B1	B2	H1	H2	H3		
15-75 GGBP3	117	58.5	90	72	58.5	115	39	2 x 24.5	2.7

PWM speed curves on request.

UPM3(K) FLEX AS 15-75 GGAOS3 (GFNKB)

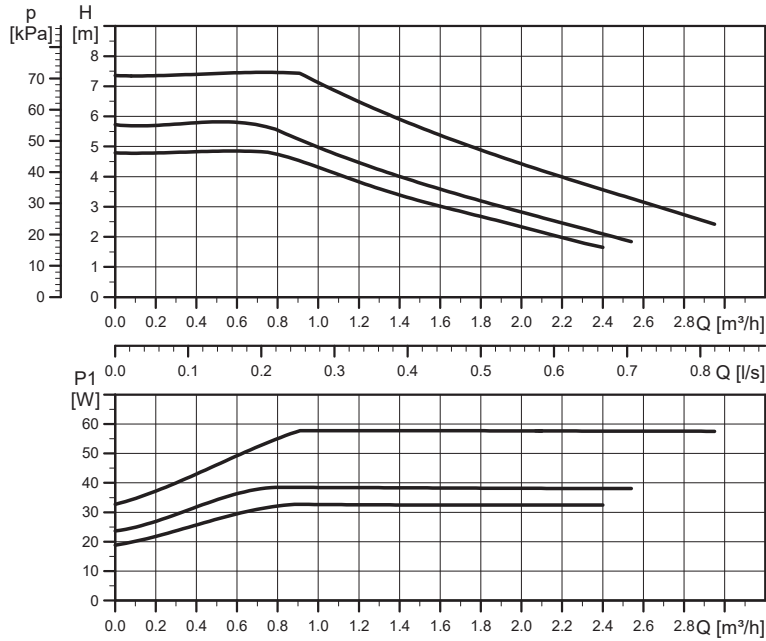

TM068620

EEI ≤ 0.20 Part 3
 P_{L,avg} ≤ 28 W

Setting	Max. head _{nom}	Max. P _{1 nom}
Curve 1	5 m	33 W
Curve 2	6 m	39 W
Curve 3	7.5 m	60 W

Pump settings				
PWM A	PWM C	PP	CP	CC
3	-	-	-	-

Electrical data, 1 x 230 V, 50 Hz				
Speed	P ₁ [W]		I _{1/1} [A]	
	Low min. speed	High min. speed	Low min. speed	High min. speed
Min.	2	4	0.04	0.05
Max.	60		0.58	

Technical data			
System pressure	Max. 1.0 MPa (10 bar)	Enclosure class	IP44 (non-condensing) K: IPX4D (condensing)
Minimum inlet pressure	0.05 MPa (0.50 bar) at 95 °C liquid temperature	Motor protection	No external protection needed
Liquid temperature	2-110 °C (TF110)	Approval and marking	VDE, CE

Dimensions

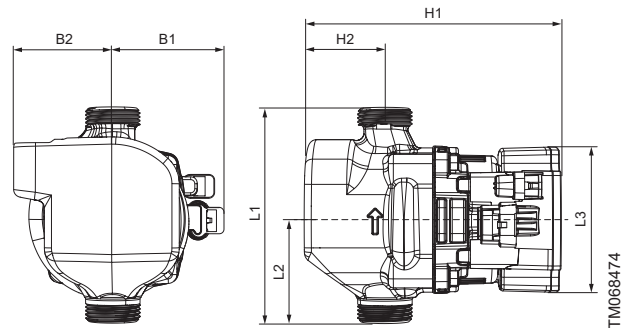

TM068474

Pump type	Dimensions [mm]							Connections [inch]	Weight [kg]
	L1	L3	B1	B2	H1	H2	H3		
15-75 GGAOS3	130	62	90	72	58	151	47	R 1/2 / G 1 Rp 3/8	1.8

PWM speed curves on request.

UPM3(K) FLEX AS 15-75 CIAO2 (GFNKB)

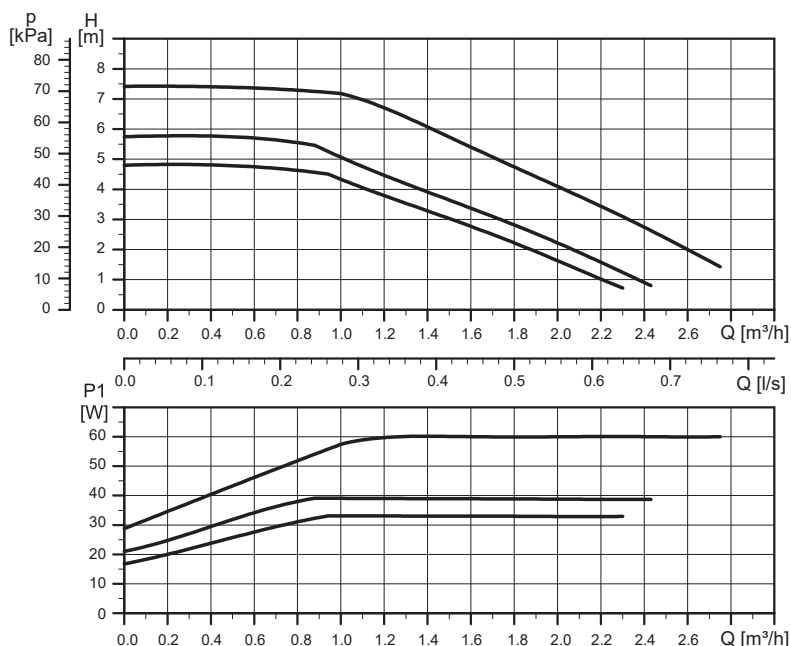

TM063868

EEl ≤ 0.20 Part 3

$P_{L,avg} \leq 28 \text{ W}$

Setting	Max. head H_{nom}	Max. P_1 $P_{1\,nom}$
Curve 1	5 m	33 W
Curve 2	6 m	39 W
Curve 3	7.5 m	60 W

Pump settings				
PWM A	PWM C	PP	CP	CC
3	-	-	-	-

Electrical data, 1 x 230 V, 50 Hz				
Speed	P_1 [W]		$I_{1/1}$ [A]	
	Low min. speed	High min. speed	Low min. speed	High min. speed
Min.	2	4	0.04	0.05
Max.	60		0.58	

Technical data			
System pressure	Max. 0.3 MPa (3 bar)	Enclosure class	IP44 (non-condensing) K: IPX4D (condensing)
Minimum inlet pressure	0.05 MPa (0.50 bar) at 95 °C liquid temperature	Motor protection	No external protection needed
Liquid temperature	2-95 °C (TF95)	Approval and marking	VDE, CE

Dimensions

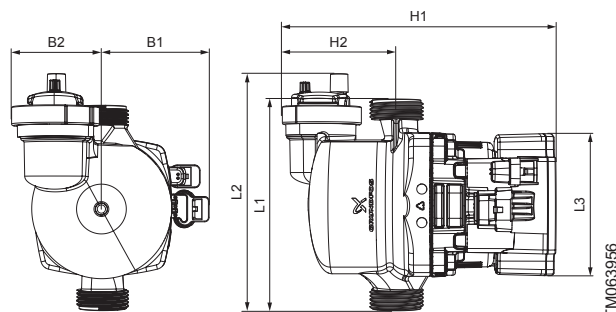

TM063956

Pump type	Dimensions [mm]							Connections [inch]	Weight [kg]
	L1	L3	B1	B2	H1	H2	H3		
15-75 CIAO2	130	148	90	72	55	173	77	R 1/2 / G 1	1.3

PWM speed curves on request.

UPM3(K) FLEX AS 15-75 CIAO2 AC (GFNKB)

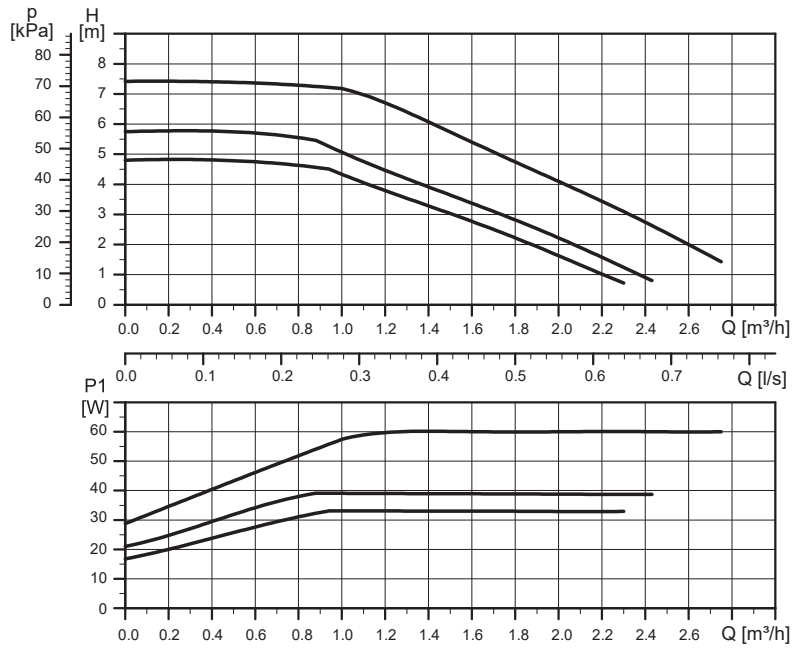

TM063868

EEI ≤ 0.20 Part 3
 P_{L,avg} ≤ 28 W

Setting	Max. head _{nom}	Max. P ₁ nom
Curve 1	5 m	33 W
Curve 2	6 m	39 W
Curve 3	7.5 m	60 W

Pump settings				
PWM A	PWM C	PP	CP	CC
4	-	-	-	-

Electrical data, 1 x 230 V, 50 Hz				
Speed	P ₁ [W]		I _{1/1} [A]	
	Low min. speed	High min. speed	Low min. speed	High min. speed
Min.	2	4	0.04	0.05
Max.	60		0.58	

Technical data			
System pressure	Max. 0.3 MPa (3 bar)	Enclosure class	IP44 (non-condensing) K: IPX4D (condensing)
Minimum inlet pressure	0.05 MPa (0.50 bar) at 95 °C liquid temperature	Motor protection	No external protection needed
Liquid temperature	2-95 °C (TF95)	Approval and marking	VDE, CE

Dimensions

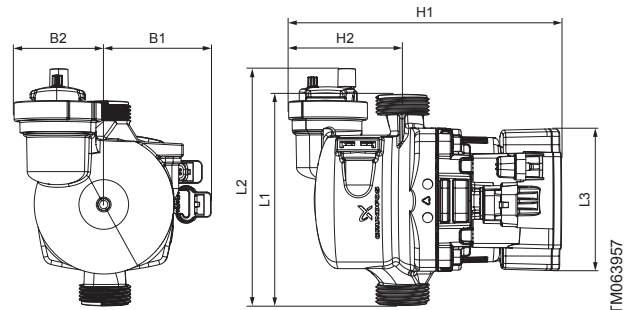

TM063957

Pump type	Dimensions [mm]							Connections [inch]	Weight [kg]
	L1	L3	B1	B2	H1	H2	H3		
15-75 CIAO2 AC	130	148	90	72	55	173	77	2 x G 1 + D 10	1.3

PWM speed curves on request.

UPM3(K) FLEX AS 15-75 CES3 (GFNKB)

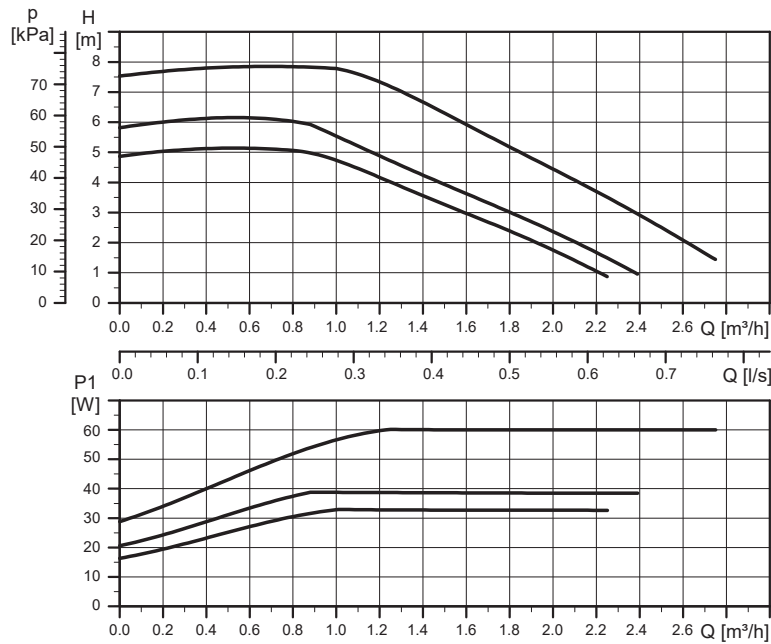

TM063863

EEl ≤ 0.20 Part 3

PL,avg ≤ 28 W

Setting	Max. head _{nom}	Max. P ₁ nom
Curve 1	5 m	33 W
Curve 2	6 m	39 W
Curve 3	7.5 m	60 W

Pump settings				
PWM A	PWM C	PP	CP	CC
3	-	-	-	-

Electrical data, 1 x 230 V, 50 Hz				
Speed	P ₁ [W]		I _{1/1} [A]	
	Low min. speed	High min. speed	Low min. speed	High min. speed
Min.	2	4	0.04	0.05
Max.	60		0.58	

Technical data			
System pressure	Max. 0.3 MPa (3 bar)	Enclosure class	IP44 (non-condensing) K: IPX4D (condensing)
Minimum inlet pressure	0.05 MPa (0.50 bar) at 95 °C liquid temperature	Motor protection	No external protection needed
Liquid temperature	2-95 °C (TF95)	Approval and marking	VDE, CE

Dimensions

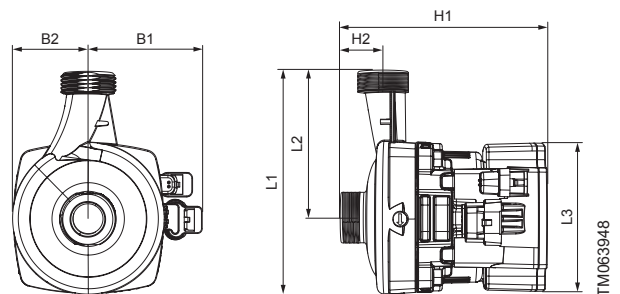

TM063948

Pump type	Dimensions [mm]							Connections [inch]	Weight [kg]
	L1	L3	B1	B2	H1	H2	H3		
15-75 CES3	132	87	90	72	47	120	25	R 1/2 / G 1	1.2

PWM speed curves on request.

UPM3(K) FLEX AS 15-75 CACAO (GFNKB)

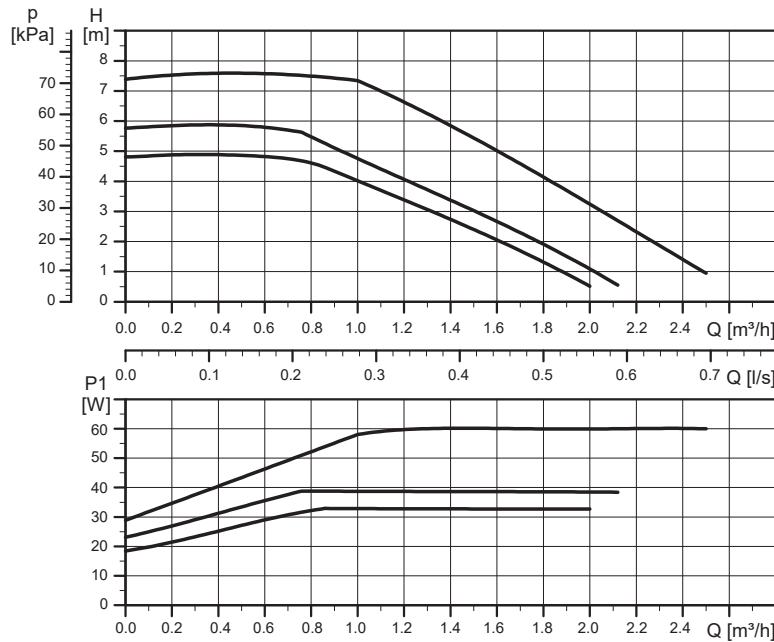

TM063862

EEl ≤ 0.20 Part 3

P_{L,avg} ≤ 28 W

Setting	Max. head nom	Max. P ₁ nom
Curve 1	5 m	33 W
Curve 2	6 m	39 W
Curve 3	7.5 m	60 W

Pump settings				
PWM A	PWM C	PP	CP	CC
3	-	-	-	-

Electrical data, 1 x 230 V, 50 Hz				
Speed	P ₁ [W]		I _{1/1} [A]	
	Low min. speed	High min. speed	Low min. speed	High min. speed
Min.	2	4	0.04	0.05
Max.	60		0.58	

Technical data			
System pressure	Max. 0.3 MPa (3 bar)	Enclosure class	IP44 (non-condensing) K: IPX4D (condensing)
Minimum inlet pressure	0.05 MPa (0.50 bar) at 95 °C liquid temperature	Motor protection	No external protection needed
Liquid temperature	2-95 °C (TF95)	Approval and marking	VDE, CE

Dimensions

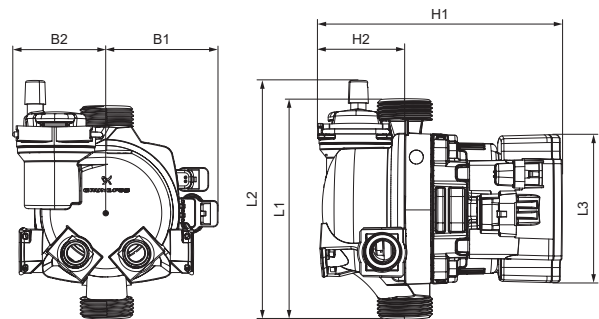

TM063953

Pump type	Dimensions [mm]							Connections [inch]	Weight [kg]
	L1	L3	B1	B2	H1	H2	H3		
15-75 CACAO	130	137	90	72	54	144	53	2 x G 1 2 x D 14 2 x D 10	1.3

PWM speed curves on request.

UPM3(K) FLEX AS 15-75 CESAO1 (GFNKB)

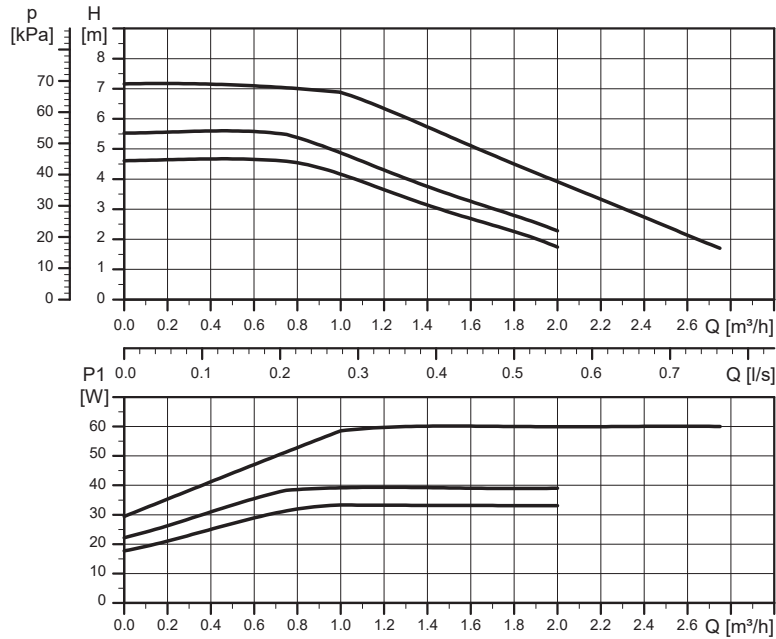

TM063864

EEI ≤ 0.20 Part 3

P_{L,avg} ≤ 28 W

Setting	Max. head _{nom}	Max. P _{1 nom}
Curve 1	5 m	33 W
Curve 2	6 m	39 W
Curve 3	7.5 m	60 W

Pump settings				
PWM A	PWM C	PP	CP	CC
3	-	-	-	-

Electrical data, 1 x 230 V, 50 Hz				
Speed	P ₁ [W]		I _{1/1} [A]	
	Low min. speed	High min. speed	Low min. speed	High min. speed
Min.	2	4	0.04	0.05
Max.	60		0.58	

Technical data			
System pressure	Max. 0.3 MPa (3 bar)	Enclosure class	IP44 (non-condensing) K: IPX4D (condensing)
Minimum inlet pressure	0.05 MPa (0.50 bar) at 95 °C liquid temperature	Motor protection	No external protection needed
Liquid temperature	2-95 °C (TF95)	Approval and marking	VDE, CE

Dimensions

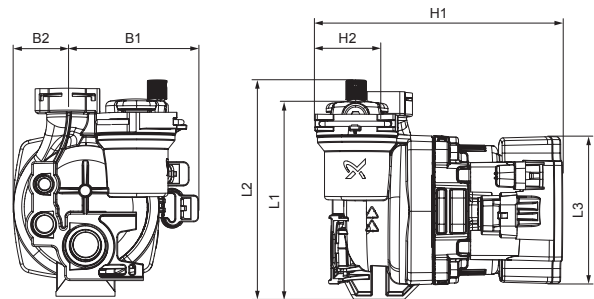

TM063950

Pump type	Dimensions [mm]							Connections [inch]	Weight [kg]
	L1	L3	B1	B2	H1	H2	H3		
15-75 CESAO1	124	128	90	72	45	144	45	2 x D 18 / D 10 / D 6	1.3

PWM speed curves on request.

UPM3(K) FLEX AS 15-75 CESAO2 (GFNKB)

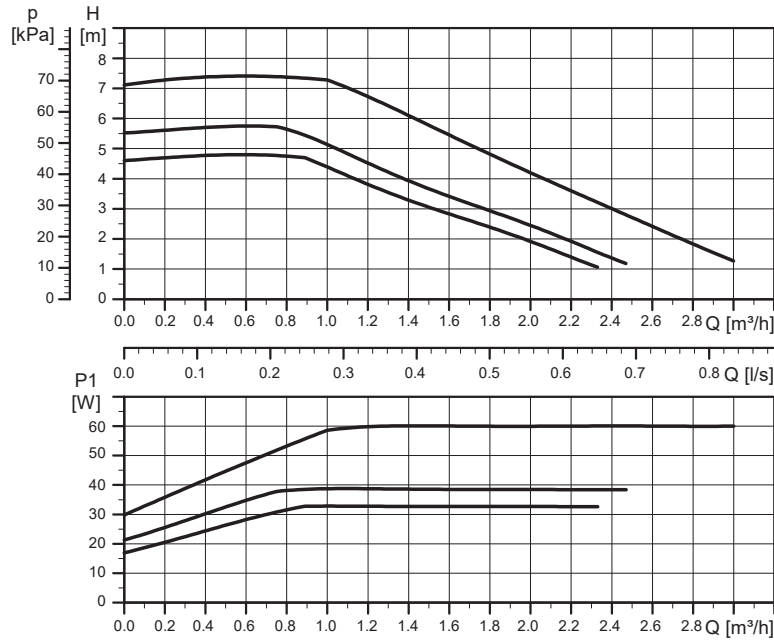

TM063865

EEI ≤ 0.20 Part 3
 P_{L,avg} ≤ 28 W

Setting	Max. head _{nom}	Max. P _{1 nom}
Curve 1	5 m	33 W
Curve 2	6 m	39 W
Curve 3	7.5 m	60 W

Pump settings				
PWM A	PWM C	PP	CP	CC
3	-	-	-	-

Electrical data, 1 x 230 V, 50 Hz				
Speed	P ₁ [W]		I _{1/1} [A]	
	Low min. speed	High min. speed	Low min. speed	High min. speed
Min.	2	4	0.04	0.05
Max.	60		0.58	

Technical data			
System pressure	Max. 0.3 MPa (3 bar)	Enclosure class	IP44 (non-condensing) K: IPX4D (condensing)
Minimum inlet pressure	0.05 MPa (0.50 bar) at 95 °C liquid temperature	Motor protection	No external protection needed
Liquid temperature	2-95 °C (TF95)	Approval and marking	VDE, CE

Dimensions

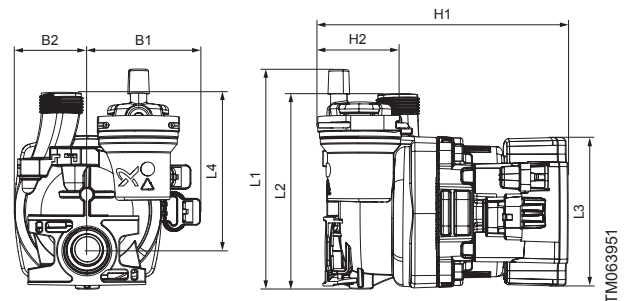

TM063951

Pump type	Dimensions [mm]						Connections [inch / mm]	Weight [kg]
	L1	L2	L3	L4	B1	B2		
15-75 CESAO2	138	116	90	87	72	45	144 45 G 3/4 / D 18 / D 10 / D 6	1.3

PWM speed curves on request.

UPM3(K) FLEX AS 15-75 CESAO4 (GFNKB)

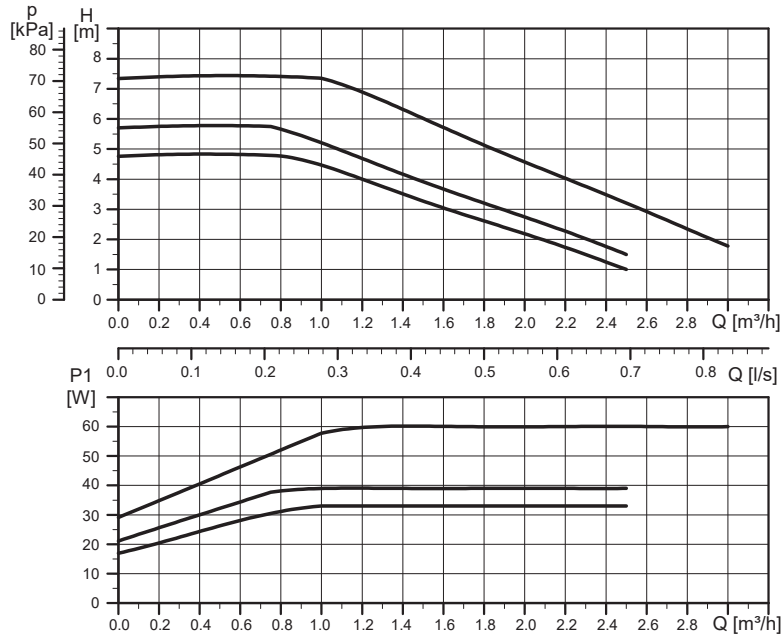

TM063867

EEI ≤ 0.20 Part 3

$P_{L,avg} \leq 28 \text{ W}$

Setting	Max. head _{nom}	Max. P ₁ nom
Curve 1	5 m	33 W
Curve 2	6 m	39 W
Curve 3	7.5 m	60 W

Pump settings				
PWM A	PWM C	PP	CP	CC
3	-	-	-	-

Electrical data, 1 x 230 V, 50 Hz				
Speed	P ₁ [W]		I _{1/1} [A]	
	Low min. speed	High min. speed	Low min. speed	High min. speed
Min.	2	4	0.04	0.05
Max.	60		0.58	

Technical data			
System pressure	Max. 0.3 MPa (3 bar)	Enclosure class	IP44 (non-condensing) K: IPX4D (condensing)
Minimum inlet pressure	0.05 MPa (0.50 bar) at 95 °C liquid temperature	Motor protection	No external protection needed
Liquid temperature	2-95 °C (TF95)	Approval and marking	VDE, CE

Dimensions

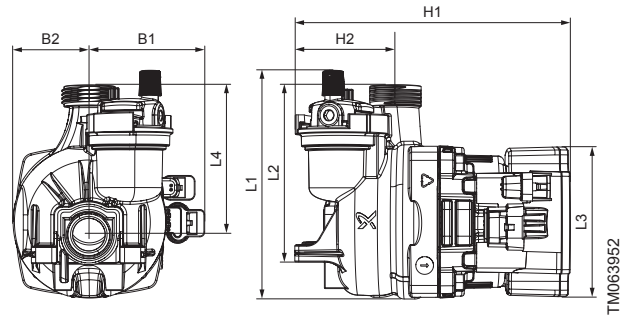

Pump type	Dimensions [mm]							Connections [inch / mm]	Weight [kg]	
	L1	L2	L3	L4	B1	B2	H1			H2
15-75 CESAO4	138	126	90	93	88	29	144	45	G 1 / D 18	1.3

PWM speed curves on request.

**UPM3(K) FLEX AS 15-75 AOKR
(GFNKB)**

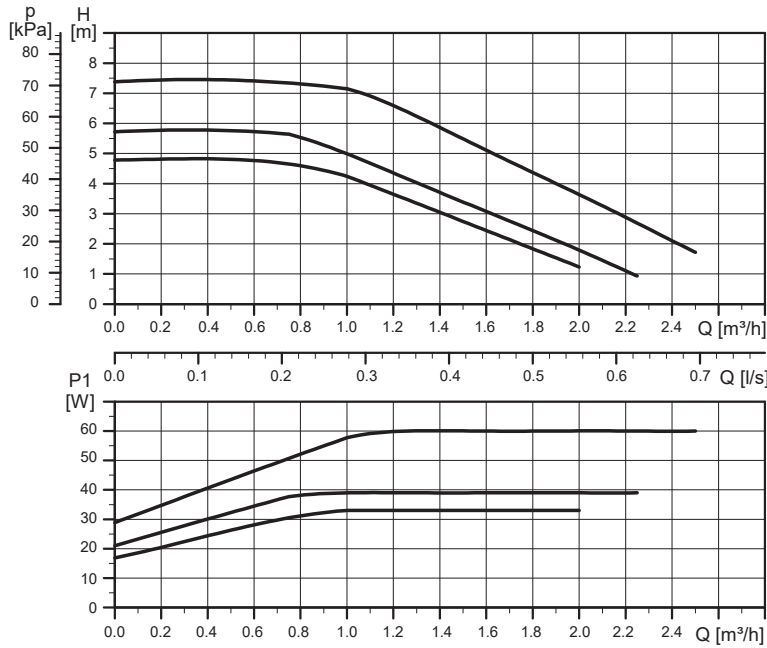

TM064092

EEI ≤ 0.20 Part 3
P_{L,avg} ≤ 28 W

Setting	Max. head _{nom}	Max. P _{1 nom}
Curve 1	5 m	33 W
Curve 2	6 m	39 W
Curve 3	7.5 m	60 W

Pump settings				
PWM A	PWM C	PP	CP	CC
3	-	-	-	-

Electrical data, 1 x 230 V, 50 Hz				
Speed	P ₁ [W]		I _{1/1} [A]	
	Low min. speed	High min. speed	Low min. speed	High min. speed
Min.	2	4	0.04	0.05
Max.	60		0.58	

Technical data			
System pressure	Max. 0.3 MPa (3 bar)	Enclosure class	IP44 (non-condensing) K: IPX4D (condensing)
Minimum inlet pressure	0.05 MPa (0.50 bar) at 95 °C liquid temperature	Motor protection	No external protection needed
Liquid temperature	2-95 °C (TF95)	Approval and marking	VDE, CE

Dimensions

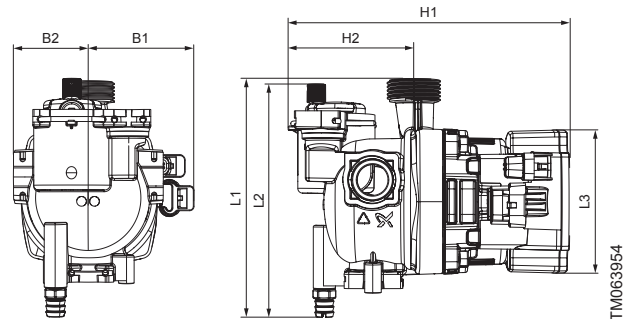

TM063954

Pump type	Dimensions [mm]							Connections [inch]	Weight [kg]
	L1	L3	B1	B2	H1	H2	H3		
15-75 AOKR	148	151	90	72	45	172	79	G 1 3 x D 28 D 21	1.4

PWM speed curves on request.

UPM3(K) FLEX AS 15-75 CAOD (GFNKB)

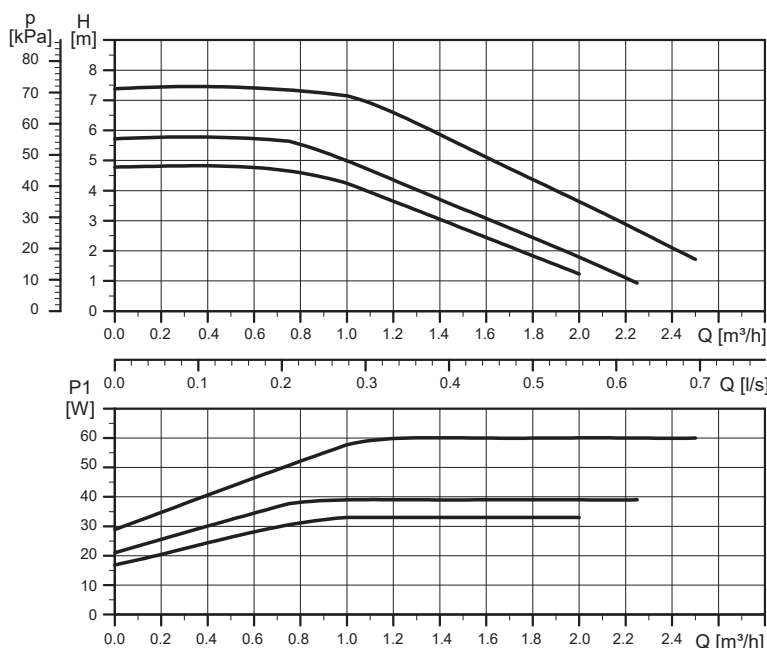

TM064092

EEI ≤ 0.20 Part 3

$P_{L,avg} \leq 28 \text{ W}$

Setting	Max. head _{nom}	Max. P ₁ nom
Curve 1	5 m	33 W
Curve 2	6 m	39 W
Curve 3	7.5 m	60 W

Pump settings				
PWM A	PWM C	PP	CP	CC
3	-	-	-	-

Electrical data, 1 x 230 V, 50 Hz				
Speed	P ₁ [W]		I _{1/1} [A]	
	Low min. speed	High min. speed	Low min. speed	High min. speed
Min.	2	4	0.04	0.05
Max.	60		0.58	

Technical data			
System pressure	Max. 0.3 MPa (3 bar)	Enclosure class	IP44 (non-condensing) K: IPX4D (condensing)
Minimum inlet pressure	0.05 MPa (0.50 bar) at 95 °C liquid temperature	Motor protection	No external protection needed
Liquid temperature	2-95 °C (TF95)	Approval and marking	VDE, CE

Dimensions

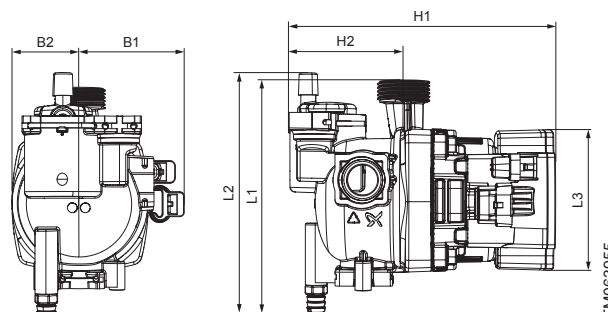

TM063955

Pump type	Dimensions [mm]							Connections [inch]	Weight [kg]
	L1	L3	B1	B2	H1	H2	H3		
15-75 CAOD	148	151	90	72	45	172	79	G 1 2 x D 28 D 21	1.4

PWM speed curves on request.

UPM3(K) AUTO XX-50 130/180 (N) (GFNKB)

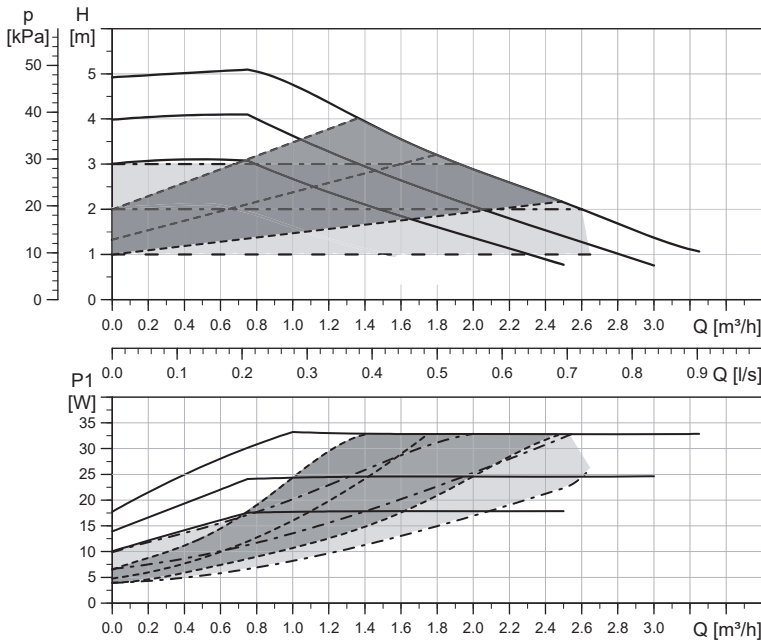

Line type	Description
————	Constant curve
-----	Proportional pressure
-----	Constant pressure

TM061180

EEI ≤ 0.20 Part 3

PL,avg ≤ 16 W

Setting	Max. head nom	Max. P ₁ nom
Curve 1	3 m	18 W
Curve 2	4 m	25 W
Curve 3	5 m	33 W

Pump settings				
PWM A	PWM C	PP	CP	CC
-	-	3/AA	3/AA	3

Electrical data, 1 x 230 V, 50 Hz		
Speed	P ₁ [W]	I _{1/1} [A]
Min.	4	0.06
Max.	33	0.36

Technical data			
System pressure	Max. 1.0 MPa (10 bar)	Enclosure class	IP44 (non-condensing) K: IPX4D (condensing)
Minimum inlet pressure	0.05 MPa (0.50 bar) at 95 °C liquid temperature	Motor protection	No external protection needed
Liquid temperature	2-110 °C (TF110)	Approval and marking	VDE, CE

Dimensions

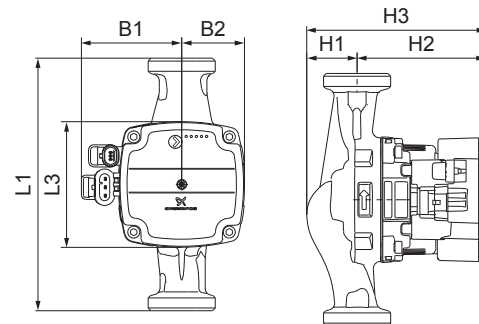

TM063879

Dimensions

Pump type	Dimensions [mm]							Connections [inch]	Weight [kg]
	L1	L3	B1	B2	H1	H2	H3		
15-50 130 (N)	130	90	72	45	36	92	128	R 1/2 / G 1	1.8
25-50 130 (N)	130	90	72	45	36	92	128	R 1 / G 1 1/2	1.9
25-50 180 (N)	180	90	72	45	36	92	128	R 1 / G 1 1/2	2.0
32-50 180 (N)	180	90	72	45	36	92	128	R 1 1/4 / G 2	2.2

UPM3(K) AUTO XX-70 130/180 (N) (GFNKB)

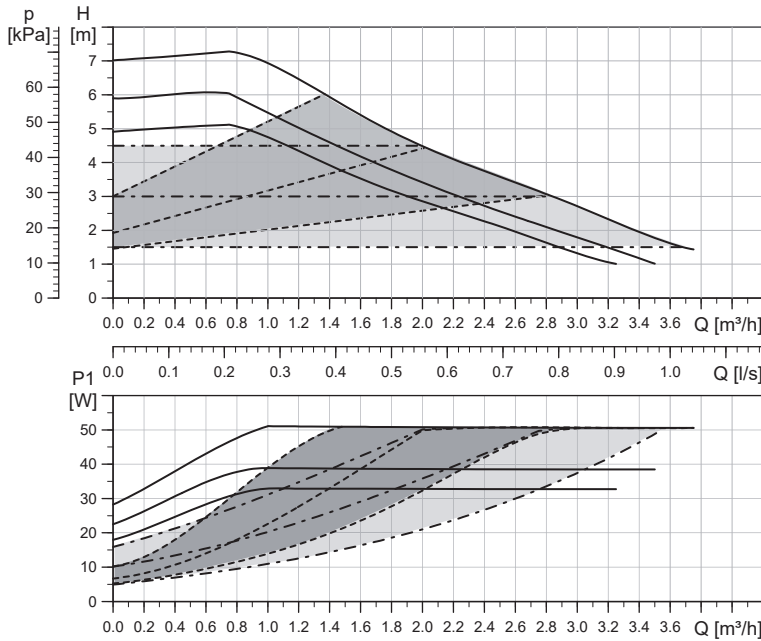

Line type	Description
—————	Constant curve
-----	Proportional pressure
- · - · - · -	Constant pressure

TM061179

EEI ≤ 0.20 Part 3

$P_{L,avg} \leq 25 \text{ W}$

Setting	Max. head H_{nom}	Max. P_1 nom
Curve 1	5 m	33 W
Curve 2	6 m	39 W
Curve 3	7 m	52 W

Pump settings				
PWM A	PWM C	PP	CP	CC
-	-	3/AA	3/AA	3

Electrical data, 1 x 230 V, 50 Hz		
Speed	P_1 [W]	$I_{1/1}$ [A]
Min.	2	0.07
Max.	52	0.52

Technical data			
System pressure	Max. 1.0 MPa (10 bar)	Enclosure class	IP44 (non-condensing) K: IPX4D (condensing)
Minimum inlet pressure	0.05 MPa (0.50 bar) at 95 °C liquid temperature	Motor protection	No external protection needed
Liquid temperature	2-110 °C (TF110)	Approval and marking	VDE, CE

Dimensions

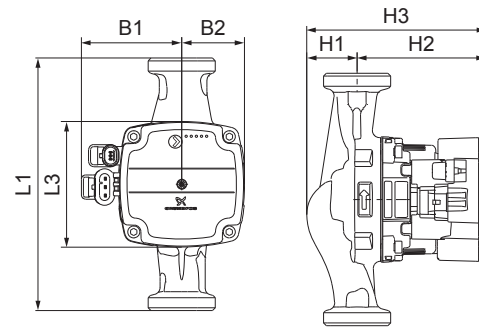

TM063879

Pump type	Dimensions [mm]							Connections [inch]	Weight [kg]
	L1	L3	B1	B2	H1	H2	H3		
15-70 130 (N)	130	90	72	45	36	92	128	R 1/2 / G 1	1.8
25-70 130 (N)	130	90	72	45	36	92	128	R 1 / G 1 1/2	1.9
25-70 180 (N)	180	90	72	45	36	92	128	R 1 / G 1 1/2	2.0
32-70 180 (N)	180	90	72	45	36	92	128	R 1 1/4 / G 2	2.2

UPM3(K) HYBRID XX-50 130/180 (N) (GFNKB)

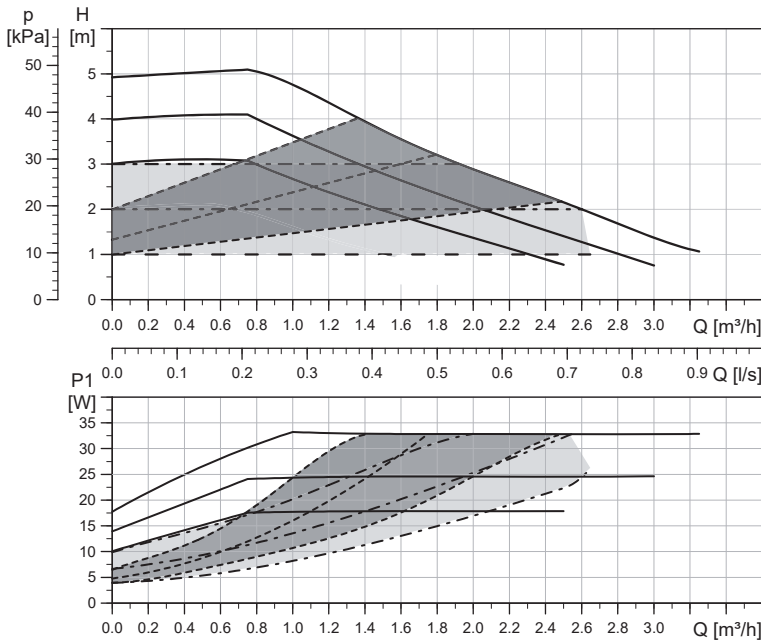

Line type	Description
————	Constant curve
-----	Proportional pressure
- . - . - .	Constant pressure

TM061180

EEI ≤ 0.20 Part 3

PL,avg ≤ 16 W

Setting	Max. head nom	Max. P ₁ nom
Curve 1	3 m	18 W
Curve 2	4 m	25 W
Curve 3	5 m	33 W

Pump settings				
PWM A	PWM C	PP	CP	CC
3	1	3/AA	3/AA	3

Electrical data, 1 x 230 V, 50 Hz		
Speed	P ₁ [W]	I _{1/1} [A]
Min.	2	0.04
Max.	33	0.36

Technical data			
System pressure	Max. 1.0 MPa (10 bar)	Enclosure class	IP44 (non-condensing) K: IPX4D (condensing)
Minimum inlet pressure	0.05 MPa (0.50 bar) at 95 °C liquid temperature	Motor protection	No external protection needed
Liquid temperature	2-110 °C (TF110)	Approval and marking	VDE, CE

Dimensions

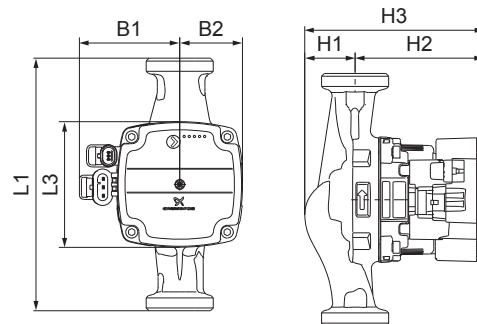

TM063879

Pump type	Dimensions [mm]							Connections [inch]	Weight [kg]
	L1	L3	B1	B2	H1	H2	H3		
15-50 130 (N)	130	90	72	45	36	92	128	R 1/2 / G 1	1.8
25-50 130 (N)	130	90	72	45	36	92	128	R 1 / G 1 1/2	1.9
25-50 180 (N)	180	90	72	45	36	92	128	R 1 / G 1 1/2	2.0
32-50 180 (N)	180	90	72	45	36	92	128	R 1 1/4 / G 2	2.2

For PWM speed curves, see 13.6 UPM3(K) XX-50 130/180 (N) (GFNKB).

UPM3(K) HYBRID XX-70 130/180 (N) (GFNKB)

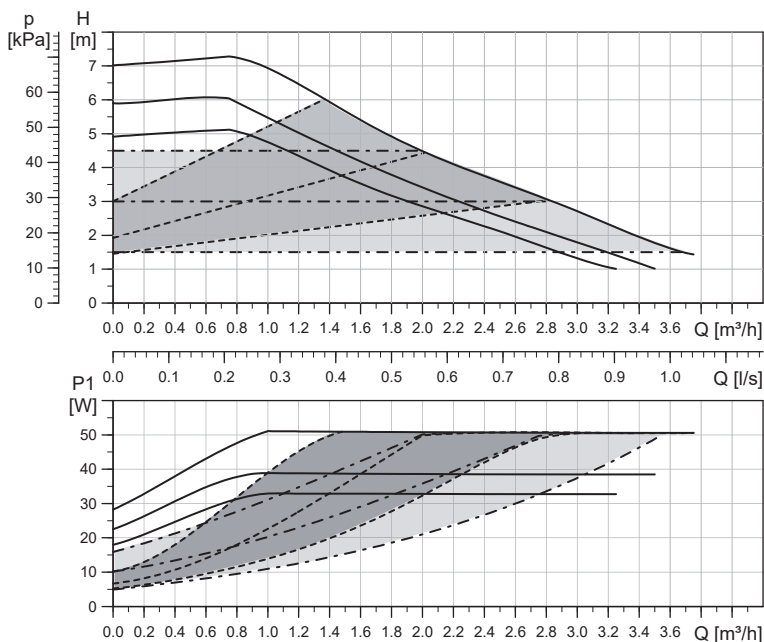

Line type	Description
—————	Constant curve
-----	Proportional pressure
-----	Constant pressure

TM061179

EEI ≤ 0.20 Part 3

P_{L,avg} ≤ 25 W

Setting	Max. head _{nom}	Max. P _{1 nom}
Curve 1	5 m	33 W
Curve 2	6 m	39 W
Curve 3	7 m	52 W

Pump settings				
PWM A	PWM C	PP	CP	CC
3	1	3/AA	3/AA	3

Electrical data, 1 x 230 V, 50 Hz		
Speed	P ₁ [W]	I _{1/1} [A]
Min.	2	0.04
Max.	52	0.52

Technical data			
System pressure	Max. 1.0 MPa (10 bar)	Enclosure class	IP44 (non-condensing) K: IPX4D (condensing)
Minimum inlet pressure	0.05 MPa (0.50 bar) at 95 °C liquid temperature	Motor protection	No external protection needed
Liquid temperature	2-110 °C (TF110)	Approval and marking	VDE, CE

Dimensions

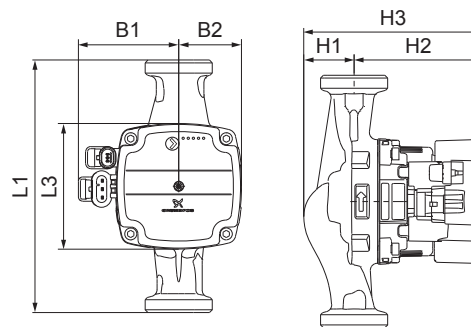

TM063879

Pump type	Dimensions [mm]							Connections [inch]	Weight [kg]
	L1	L3	B1	B2	H1	H2	H3		
15-70 130 (N)	130	90	72	45	36	92	128	R 1/2 / G 1	1.8
25-70 130 (N)	130	90	72	45	36	92	128	R 1 / G 1 1/2	1.9
25-70 180 (N)	180	90	72	45	36	92	128	R 1 / G 1 1/2	2.0
32-70 180 (N)	180	90	72	45	36	92	128	R 1 1/4 / G 2	2.2

For PWM speed curves, see [13.8 UPM3\(K\) XX-70 130/180 \(N\) \(GFNKB\)](#).

UPM3(K) DHW XX-20 130/180 N (GFNKB)

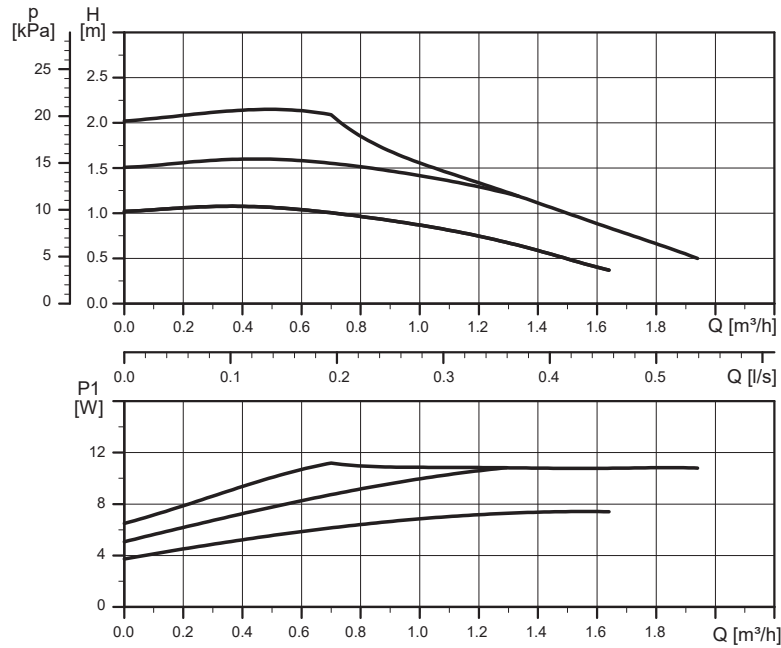

TM064075

EEI ≤ 0.20 Part 3

$P_{L,avg} \leq 7 \text{ W}$

Setting	Max. head _{nom}	Max. P _{1 nom}
Curve 1	1 m	7 W
Curve 2	1.5 m	9 W
Curve 3	2 m	11 W

Pump settings				
PWM A	PWM C	PP	CP	CC
3	-	-	-	-

Electrical data, 1 x 230 V, 50 Hz		
Speed	P ₁ [W]	I _{1/1} [A]
Min.	2	0.04
Max.	12	0.14

Technical data			
System pressure	Max. 1.0 MPa (10 bar)	Enclosure class	IP44 (non-condensing) K: IPX4D (condensing)
Minimum inlet pressure	0.05 MPa (0.50 bar) at 95 °C liquid temperature	Motor protection	No external protection needed
Liquid temperature	2-110 °C (TF110)	Approval and marking	VDE, CE, UBA (DE), ACS (FR), WRAS (UK)
Temporary hardness	Max. 3 mmol/l CaCO ₃ (16.8 ° dH)		

Dimensions

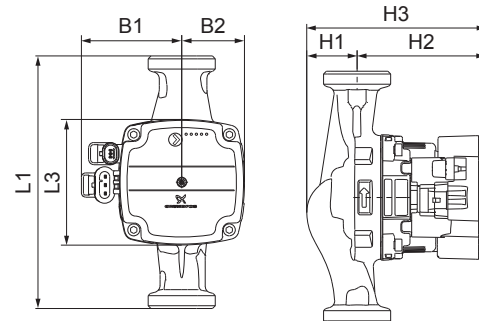

TM063879

Pump type	Dimensions [mm]							Connections [inch]	Weight [kg]
	L1	L3	B1	B2	H1	H2	H3		
25-20 130 N	130	90	72	45	36	92	128	R 1 / G 1 1/2	2.1
25-20 180 N	180	90	72	45	36	92	128	R 1 / G 1 1/2	2.2
32-20 180 N	180	90	72	45	36	92	128	R 1 1/4 / G 2	2.4

PWM speed curves on request.

UPM3(K) DHW XX-50 130/180 N (GFNKB)

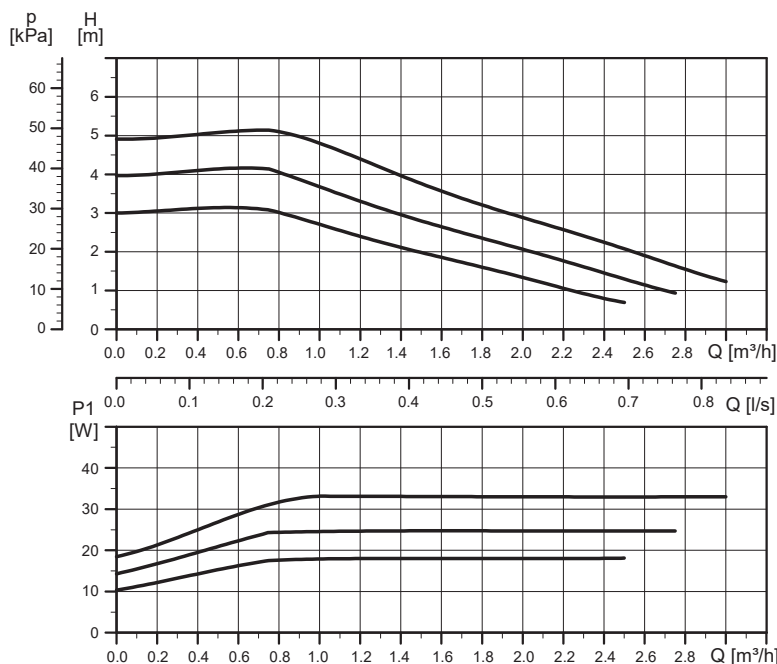

TM064074

EEI ≤ 0.20 Part 3

PL,avg ≤ 16 W

Setting	Max. head _{nom}	Max. P ₁ nom
Curve 1	3 m	18 W
Curve 2	4 m	25 W
Curve 3	5 m	33 W

Pump settings				
PWM A	PWM C	PP	CP	CC
3	-	-	-	-

Electrical data, 1 x 230 V, 50 Hz		
Speed	P ₁ [W]	I _{1/1} [A]
Min.	2	0.04
Max.	33	0.36

Technical data			
System pressure	Max. 1.0 MPa (10 bar)	Enclosure class	IP44 (non-condensing) K: IPX4D (condensing)
Minimum inlet pressure	0.05 MPa (0.50 bar) at 95 °C liquid temperature	Motor protection	No external protection needed
Liquid temperature	2-110 °C (TF110)	Approval and marking	VDE, CE, UBA (DE), ACS (FR), WRAS (UK)
Temporary hardness	Max. 3 mmol/l CaCO ₃ (16.8 ° dH)		

Dimensions

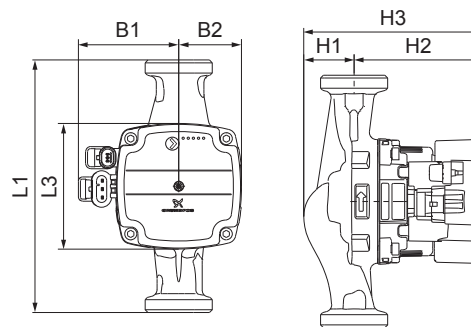

TM063879

Pump type	Dimensions [mm]							Connections [inch]	Weight [kg]
	L1	L3	B1	B2	H1	H2	H3		
25-50 130 N	130	90	72	45	36	92	128	R 1 / G 1 1/2	2.1
25-50 180 N	180	90	72	45	36	92	128	R 1 / G 1 1/2	2.2
32-50 180 N	180	90	72	45	36	92	128	R 1 1/4 / G 2	2.4

For PWM speed curves, see [13.6 UPM3\(K\) XX-50 130/180 \(N\) \(GFNKB\)](#).

UPM3(K) DHW XX-70 130/180 N (GFNKB)

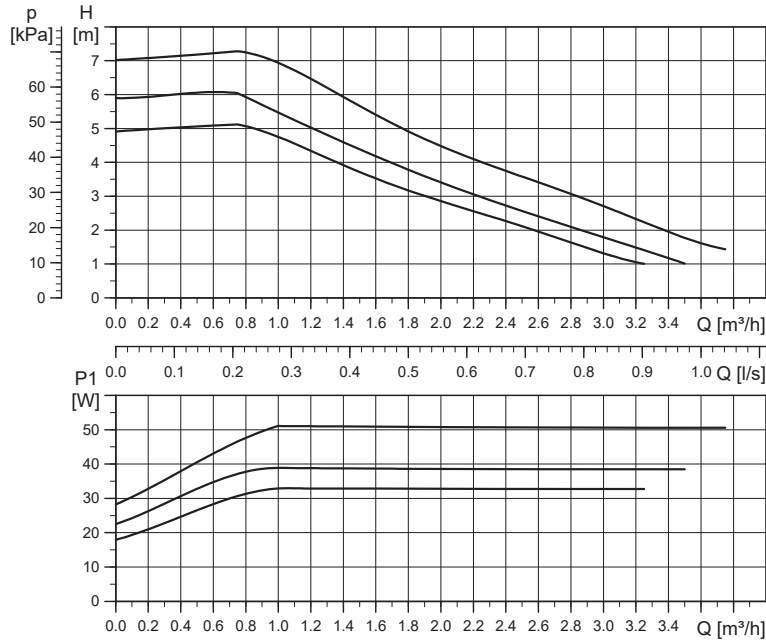

TM060584

EEL ≤ 0.20 Part 3

PL,avg ≤ 23 W

Setting	Max. head _{nom}	Max. P ₁ _{nom}
Curve 1	5 m	33 W
Curve 2	6 m	39 W
Curve 3	7 m	52 W

Pump settings				
PWM A	PWM C	PP	CP	CC
3	-	-	-	-

Electrical data, 1 x 230 V, 50 Hz		
Speed	P ₁ [W]	I _{1/1} [A]
Min.	2	0.04
Max.	52	0.52

Technical data			
System pressure	Max. 1.0 MPa (10 bar)	Enclosure class	IP44 (non-condensing) K: IPX4D (condensing)
Minimum inlet pressure	0.05 MPa (0.50 bar) at 95 °C liquid temperature	Motor protection	No external protection needed
Liquid temperature	2-110 °C (TF110)	Approval and marking	VDE, CE, UBA (DE), ACS (FR), WRAS (UK)
Temporary hardness	Max. 3 mmol/l CaCO ₃ (16.8 ° dH)		

Dimensions

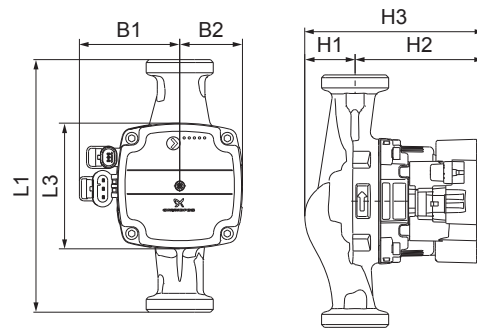

TM063879

Pump type	Dimensions [mm]							Connections [inch]	Weight [kg]
	L1	L3	B1	B2	H1	H2	H3		
25-70 130 N	130	90	72	45	36	92	128	R 1 / G 1 1/2	2.1
25-70 180 N	180	90	72	45	36	92	128	R 1 / G 1 1/2	2.2
32-70 180 N	180	90	72	45	36	92	128	R 1 1/4 / G 2	2.4

For PWM speed curves, see [13.8 UPM3\(K\) XX-70 130/180 \(N\) \(GFNKB\)](#).

UPM3(K) DHW 15-20 CIL3 PPS (GFNKB)

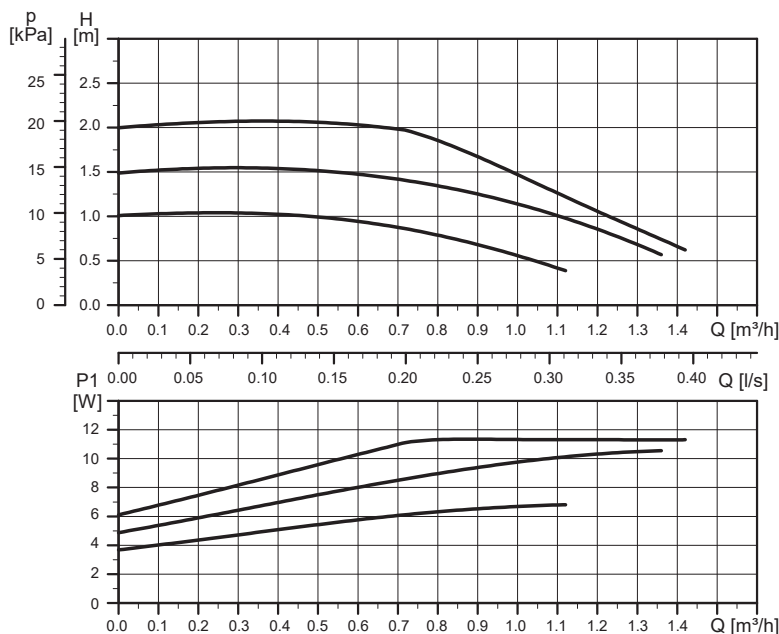

TM064078

EEI ≤ 0.20 Part 3

$P_{L,avg} \leq 7 \text{ W}$

Setting	Max. head _{nom}	Max. P ₁ _{nom}
Curve 1	1 m	7 W
Curve 2	1.5 m	9 W
Curve 3	2 m	11 W

Pump settings				
PWM A	PWM C	PP	CP	CC
3	-	-	-	-

Electrical data, 1 x 230 V, 50 Hz		
Speed	P ₁ [W]	I _{1/1} [A]
Min.	2	0.04
Max.	12	0.14

Technical data			
System pressure	Max. 1.0 MPa (10 bar)	Enclosure class	IP44 (non-condensing) K: IPX4D (condensing)
Minimum inlet pressure	0.05 MPa (0.50 bar) at 95 °C liquid temperature	Motor protection	No external protection needed
Liquid temperature	2-95 °C (TF95)	Approval and marking	VDE, CE, UBA (DE), ACS (FR), WRAS (UK)
Temporary hardness	Max. 3 mmol/l CaCO ₃ (16.8 ° dH)		

Dimensions

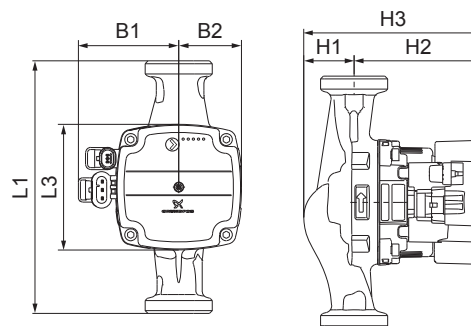

TM063879

Pump type	Dimensions [mm]							Connections [inch]	Weight [kg]
	L1	L3	B1	B2	H1	H2	H3		
15-20 CIL3 PPS	130	90	72	45	36	92	128	R 1/2 / G 1	1.3

PWM speed curves on request.

UPM3(K) DHW 15-50 CIL3 PPS (GFNKB)

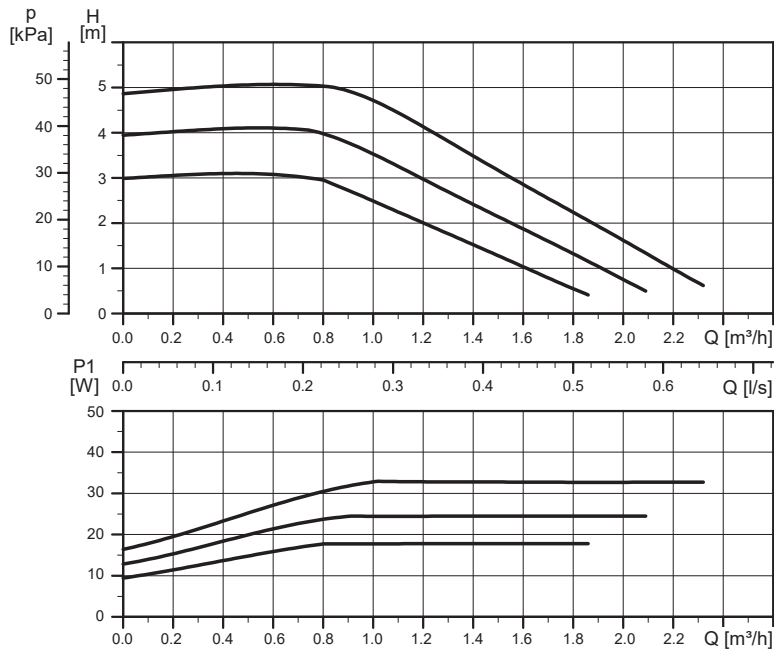

TM064077

EEI ≤ 0.20 Part 3

$P_{L,avg} \leq 16 \text{ W}$

Setting	Max. head $_{nom}$	Max. P_1 $_{nom}$
Curve 1	3 m	18 W
Curve 2	4 m	25 W
Curve 3	5 m	33 W

Pump settings

PWM A	PWM C	PP	CP	CC
3	-	-	-	-

Electrical data, 1 x 230 V, 50 Hz

Speed	P_1 [W]	$I_{1/1}$ [A]
Min.	2	0.04
Max.	33	0.34

Technical data

System pressure	Max. 1.0 MPa (10 bar)	Enclosure class	IP44 (non-condensing) K: IPX4D (condensing)
Minimum inlet pressure	0.05 MPa (0.50 bar) at 95 °C liquid temperature	Motor protection	No external protection needed
Liquid temperature	2-95 °C (TF95)	Approval and marking	VDE, CE, UBA (DE), ACS (FR), WRAS (UK)
Temporary hardness	Max. 3 mmol/l CaCO ₃ (16.8 ° dH)		

Dimensions

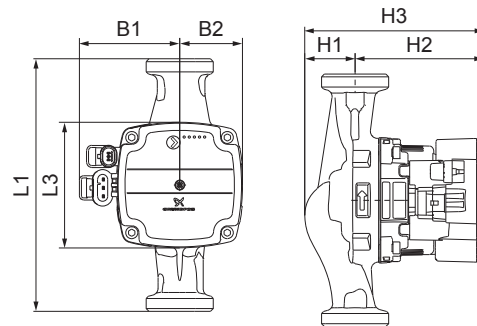

TM063879

Pump type	Dimensions [mm]							Connections [inch]	Weight [kg]
	L1	L3	B1	B2	H1	H2	H3		
15-50 CIL3 PPS	130	90	72	45	36	92	128	R 1/2 / G 1	1.3

PWM speed curves on request.

UPM3(K) DHW 15-70 CIL3 PPS (GFNKB)

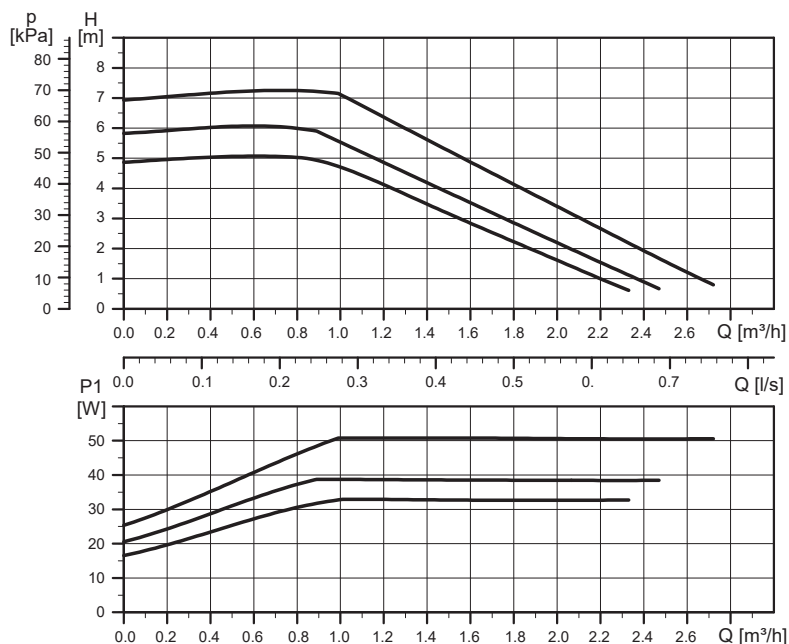

TM064076

EEI ≤ 0.20 Part 3

P_{L,avg} ≤ 23 W

Setting	Max. head _{nom}	Max. P _{1 nom}
Curve 1	5 m	33 W
Curve 2	6 m	39 W
Curve 3	7 m	52 W

Pump settings				
PWM A	PWM C	PP	CP	CC
3	-	-	-	-

Electrical data, 1 x 230 V, 50 Hz		
Speed	P ₁ [W]	I _{1/1} [A]
Min.	2	0.04
Max.	52	0.52

Technical data			
System pressure	Max. 1.0 MPa (10 bar)	Enclosure class	IP44 (non-condensing) K: IPX4D (condensing)
Minimum inlet pressure	0.05 MPa (0.50 bar) at 95 °C liquid temperature	Motor protection	No external protection needed
Liquid temperature	2-95 °C (TF95)	Approval and marking	VDE, CE, UBA (DE), ACS (FR), WRAS (UK)
Temporary hardness	Max. 3 mmol/l CaCO ₃ (16.8 ° dH)		

Dimensions

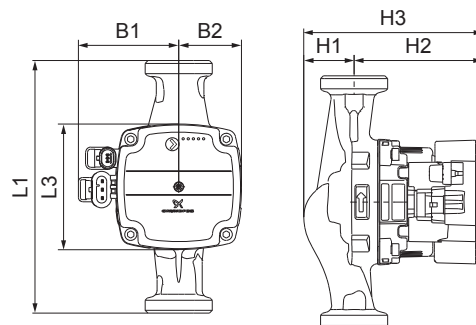

TM063879

Pump type	Dimensions [mm]							Connections [inch]	Weight [kg]
	L1	L3	B1	B2	H1	H2	H3		
15-70 CIL3 PPS	130	90	72	45	36	92	128	R 1/2 / G 1	1.3

PWM speed curves on request.

**UPM3(K) SOLAR XX-75 130/180 (N)
(GFNKB)**

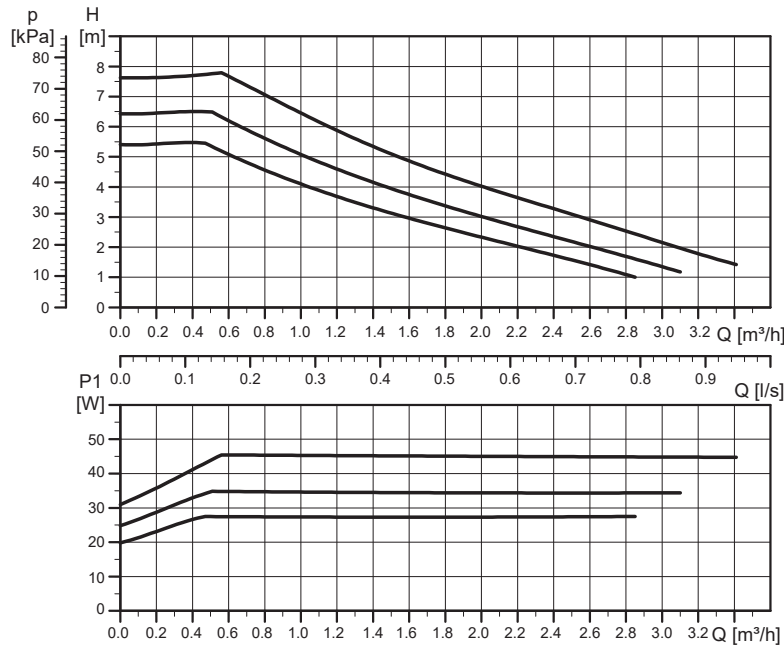

TM063658

EEI ≤ 0.20 Part 3

PL,avg ≤ 20 W

Setting	Max. head _{nom}	Max. P ₁ nom
Curve 1	5.5 m	28 W
Curve 2	6.5 m	35 W
Curve 3	7.5 m	45 W

Pump settings				
PWM A	PWM C	PP	CP	CC
-	1	-	-	3

Electrical data, 1 x 230 V, 50 Hz		
Speed	P ₁ [W]	I _{1/1} [A]
Min.	2	0.04
Max.	45	0.48

Technical data			
System pressure	Max. 1.0 MPa (10 bar)	Enclosure class	IPX4D
Minimum inlet pressure	0.05 MPa (0.50 bar) at 95 °C liquid temperature	Motor protection	No external protection needed
Liquid temperature	2-110 °C (TF110) Max. 130 °C (60 °C ambient temperature)	Approval and marking	VDE, CE

Dimensions

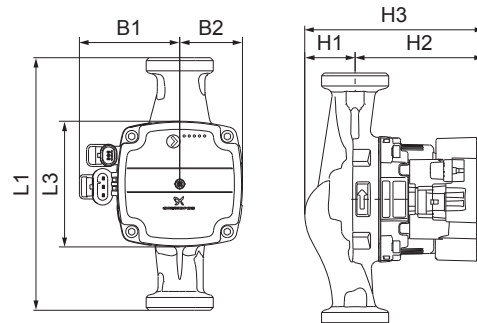

TM063879

Pump type	Dimensions [mm]							Connections [inch]	Weight [kg]
	L1	L3	B1	B2	H1	H2	H3		
15-75 130 (N)	130	90	72	45	36	92	128	R 1/2 / G 1	1.8
25-75 130 (N)	130	90	72	45	36	92	128	R 1 / G 1 1/2	1.9
25-75 180 (N)	180	90	72	45	36	92	128	R 1 / G 1 1/2	2.0
32-75 180 (N)	180	90	72	45	36	92	128	R 1 1/4 / G 2	2.2

PWM speed curves on request.

UPM3(K) SOLAR XX-105 130/180 (GFNKB)

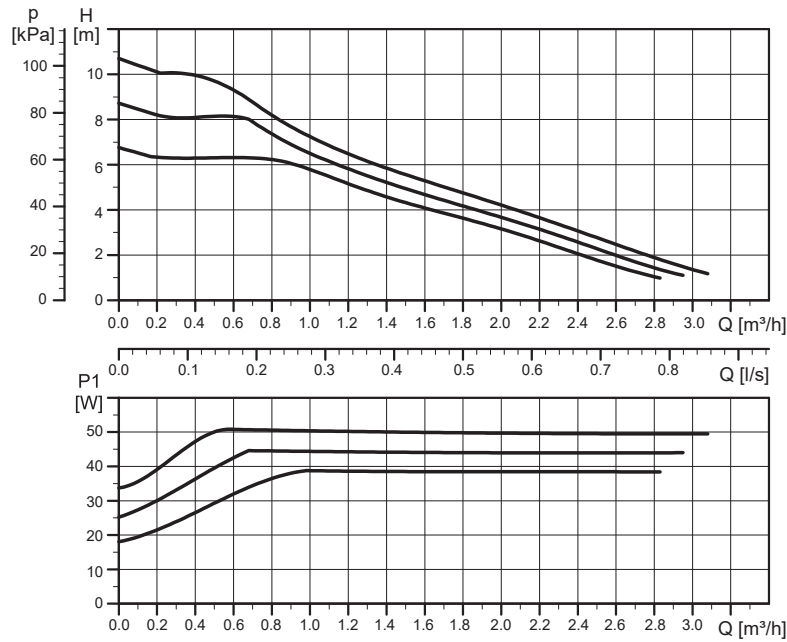

TM063651

EEI ≤ 0.20 Part 3

$P_{L,avg} \leq 22 \text{ W}$

Setting	Max. head _{nom}	Max. P ₁ nom
Curve 1	6.5 m	39 W
Curve 2	8.5 m	45 W
Curve 3	10.5 m	52 W

Pump settings				
PWM A	PWM C	PP	CP	CC
-	1	-	-	3

Electrical data, 1 x 230 V, 50 Hz		
Speed	P ₁ [W]	I _{1/1} [A]
Min.	2	0.04
Max.	52	0.52

Technical data			
System pressure	Max. 1.0 MPa (10 bar)	Enclosure class	IPX4D
Minimum inlet pressure	0.05 MPa (0.50 bar) at 95 °C liquid temperature	Motor protection	No external protection needed
Liquid temperature	2-110 °C (TF110) Max. 130 °C (60 °C ambient temperature)	Approval and marking	VDE, CE

Dimensions

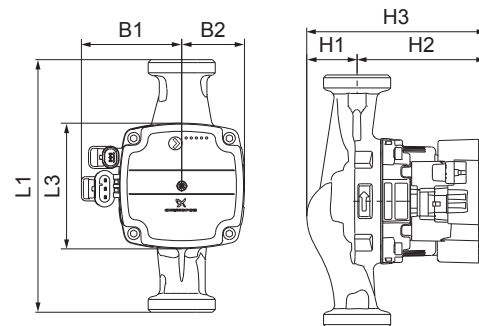

TM063879

Pump type	Dimensions [mm]							Connections [inch]	Weight [kg]
	L1	L3	B1	B2	H1	H2	H3		
15-105 130	130	90	72	47	25.5	102	127.5	R 1/2 / G 1	1.8
25-105 130	130	90	72	47	25.5	102	127.5	R 1 / G 1 1/2	1.9
25-105 180	180	90	72	47	25.5	102	127.5	R 1 / G 1 1/2	2.0

PWM speed curves on request.

UPM3(K) SOLAR XX-145 130/180 (GFNKB)

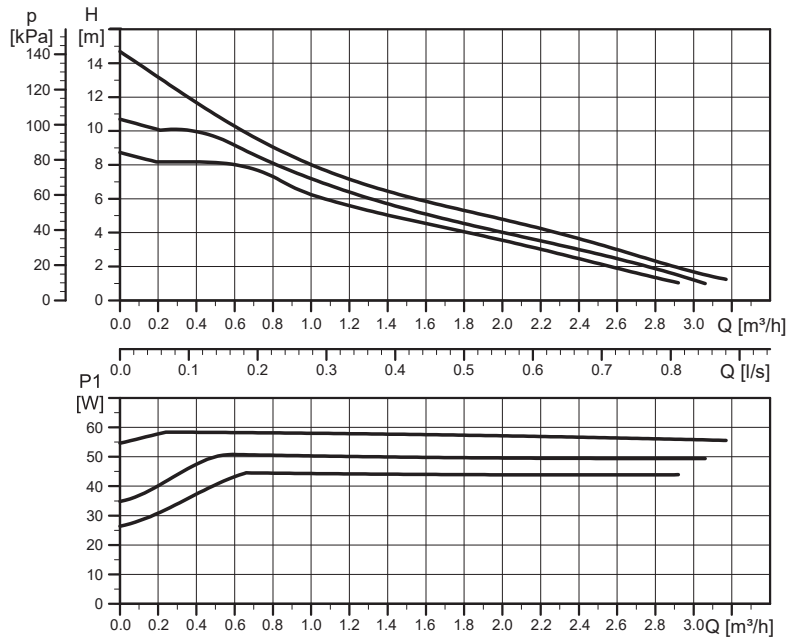

TM063652

EEI ≤ 0.20 Part 3

$P_{L,avg} \leq 25 \text{ W}$

Setting	Max. head _{nom}	Max. P ₁ nom
Curve 1	8.5 m	45 W
Curve 2	10.5 m	52 W
Curve 3	14.5 m	60 W

Pump settings				
PWM A	PWM C	PP	CP	CC
-	1	-	-	3

Electrical data, 1 x 230 V, 50 Hz		
Speed	P ₁ [W]	I _{1/1} [A]
Min.	2	0.04
Max.	60	0.58

Technical data			
System pressure	Max. 1.0 MPa (10 bar)	Enclosure class	IPX4D
Minimum inlet pressure	0.05 MPa (0.50 bar) at 95 °C liquid temperature	Motor protection	No external protection needed
Liquid temperature	2-110 °C (TF110) Max. 130 °C (60 °C ambient temperature)	Approval and marking	VDE, CE

Dimensions

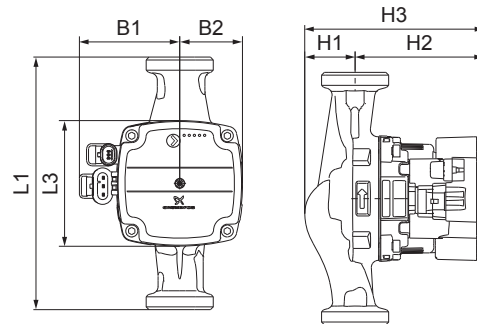

TM063879

Pump type	Dimensions [mm]							Connections [inch]	Weight [kg]
	L1	L3	B1	B2	H1	H2	H3		
15-145 130	130	90	72	47	25.5	102	127.5	R 1/2 / G 1	1.8
25-145 130	130	90	72	47	25.5	102	127.5	R 1 / G 1 1/2	1.9
25-145 180	180	90	72	47	25.5	102	127.5	R 1 / G 1 1/2	2.0

PWM speed curves on request.

UPM3L XX-75 130/180 (N) (GFNKC)

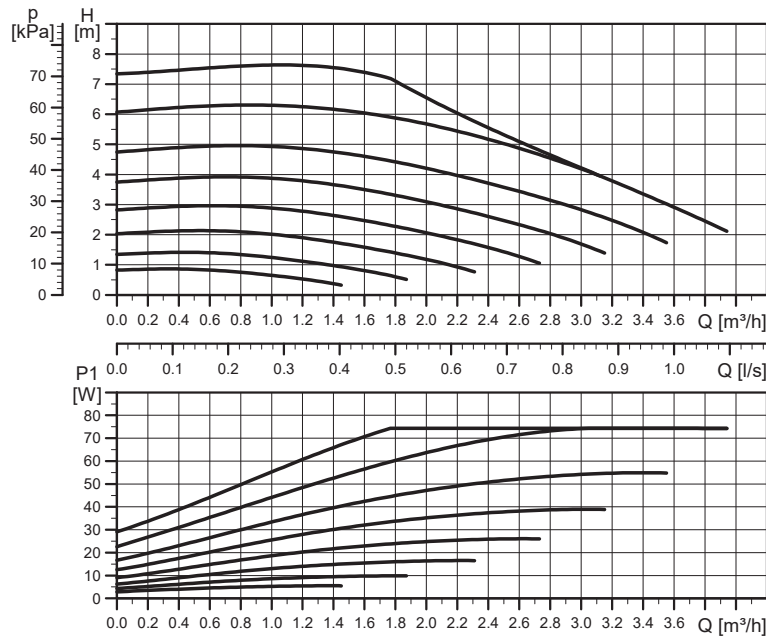

TM068615

EEI ≤ 0.20 Part 3

$P_{L,avg} \leq 32 \text{ W}$

Pump settings			
1 factory preset			
Electrical data, 1 x 230 V, 50 Hz			
Speed	P_1 [W]	$I_{1/1}$ [A]	
Min.	2	0.04	
Max.	75	0.65	
Technical data			
System pressure	Max. 1.0 MPa (10 bar)	Enclosure class	IP44 (non-condensing) K: IPX4D (condensing)
Minimum inlet pressure	0.05 MPa (0.50 bar) at 95 °C liquid temperature	Motor protection	No external protection needed
Liquid temperature	2-95 °C (TF110)	Approval and marking	VDE, CE

Dimensions

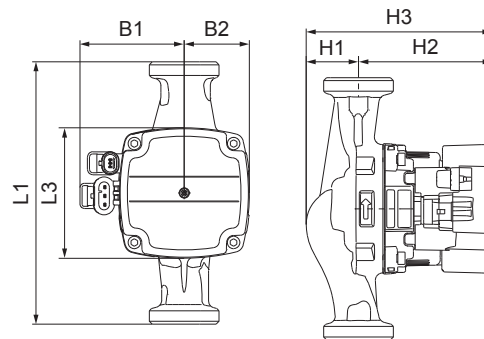

TM063878

Pump type	Dimensions [mm]							Connections [inch]	Weight [kg]
	L1	L3	B1	B2	H1	H2	H3		
15-75 130 (N)	130	90	72	45	36	92	128	R 1/2 / G 1	1.8
25-75 130 (N)	130	90	72	45	36	92	128	R 1 / G 1 1/2	1.9
25-75 180 (N)	180	90	72	45	36	92	128	R 1 / G 1 1/2	2.0
32-75 180 (N)	180	90	72	45	36	92	128	R 1 1/4 / G 2	2.2

UPM3L FLEX AS XX-75 130/180 (N) (GFNKC)

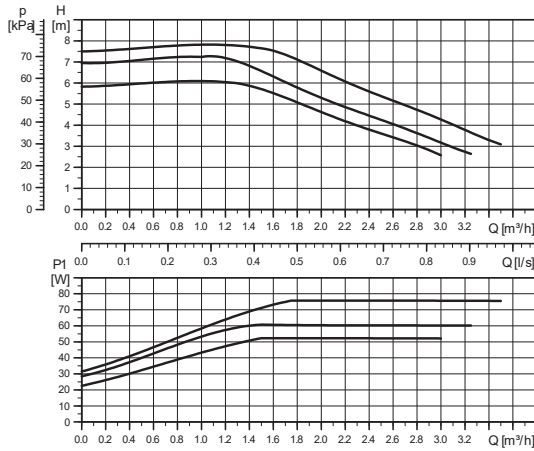

TM070138

EEI ≤ 0.20 Part 3
PL,avg ≤ 32 W

Setting	Max. head _{nom}	Max. P ₁ nom
Curve 1	6	52
Curve 2	7	60
Curve 3	7.5	75

Pump settings				
PWM A	PWM C	PP	CP	CC
3	-	-	-	-

Electrical data, 1 x 230 V, 50 Hz		
Speed	P ₁ [W]	I _{1/1} [A]
Min.	2	0.04
Max.	75	0.65

Technical data			
System pressure	Max. 1.0 MPa (10 bar)	Enclosure class	IP44 (non-condensing) K: IPX4D (condensing)
Minimum inlet pressure	0.05 MPa (0.50 bar) at 95 °C liquid temperature	Motor protection	No external protection needed
Liquid temperature	2-95 °C (TF110)	Approval and marking	VDE, CE

Dimensions

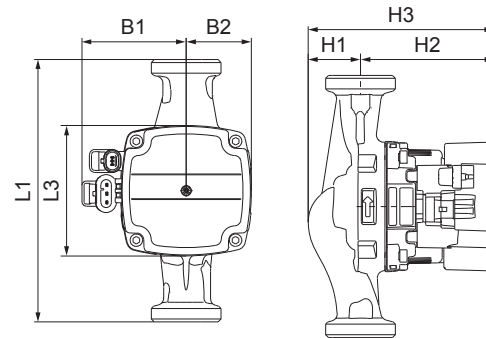

TM063878

Pump type	Dimensions [mm]							Connections [inch]	Weight [kg]
	L1	L3	B1	B2	H1	H2	H3		
15-75 130 (N)	130	90	72	45	36	92	128	R 1/2 / G 1	1.8
25-75 130 (N)	130	90	72	45	36	92	128	R 1 / G 1 1/2	1.9
25-75 180 (N)	180	90	72	45	36	92	128	R 1 / G 1 1/2	2.0
32-75 180 (N)	180	90	72	45	36	92	128	R 1 1/4 / G 2	2.2

For PWM speed curves, see [13.40 UPM3L XX-75 130/180 \(N\) \(GFNKC\)](#).

UPM3L AUTO XX-70 130/180 (N)

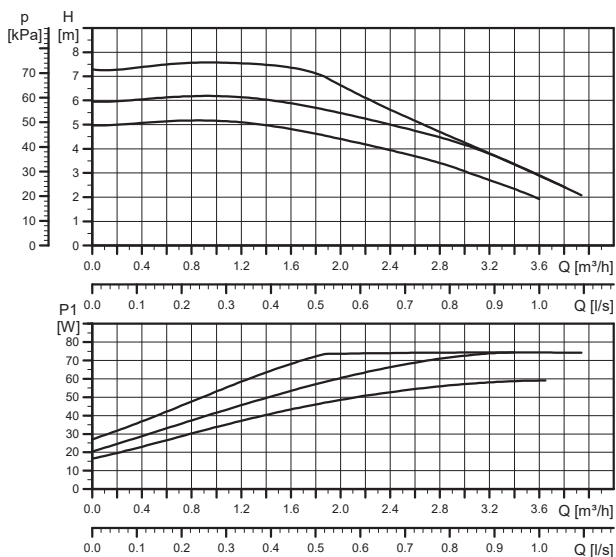

Line type	Description
————	Constant curve
-----	Proportional pressure
.....	Constant pressure

EEI ≤ 0.20 Part 3

PL,avg ≤ 32 W

Setting	Max. head _{nom}	Max. P ₁ nom
Curve 1	5 m	60 W
Curve 2	6 m	75 W
Curve 3	7 m	75 W

Pump settings				
PWM A	PWM C	PP	CP	CC
-	-	3/AA	3/AA	3

Electrical data, 1 x 230 V, 50 Hz		
Speed	P ₁ [W]	I _{1/1} [A]
Min.	2	0.04
Max.	75	0.65

Technical data			
System pressure	Max. 1.0 MPa (10 bar)	Enclosure class	IP44 (non-condensing) K: IPX4D (condensing)
Minimum inlet pressure	0.05 MPa (0.50 bar) at 95 °C liquid temperature	Motor protection	No external protection needed
Liquid temperature	2-110 °C (TF110)	Approval and marking	VDE, CE

Dimensions

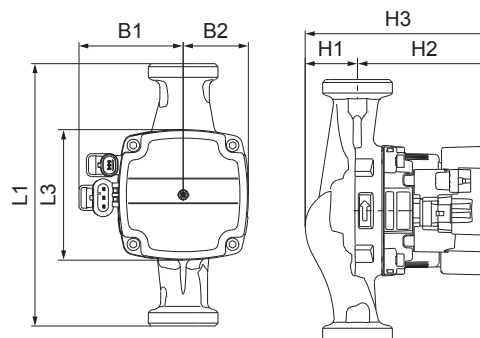

TM063878

Dimensions

Pump type	Dimensions [mm]							Connections [inch]	Weight [kg]
	L1	L3	B1	B2	H1	H2	H3		
15-75 130 (N)	130	90	72	45	36	92	128	R 1/2 / G 1	1.8
25-75 130 (N)	130	90	72	45	36	92	128	R 1 / G 1 1/2	1.9
25-75 180 (N)	180	90	72	45	36	92	128	R 1 / G 1 1/2	2.0
32-75 180 (N)	180	90	72	45	36	92	128	R 1 1/4 / G 2	2.2

UPM3L HYBRID XX-70 130/180 (N)

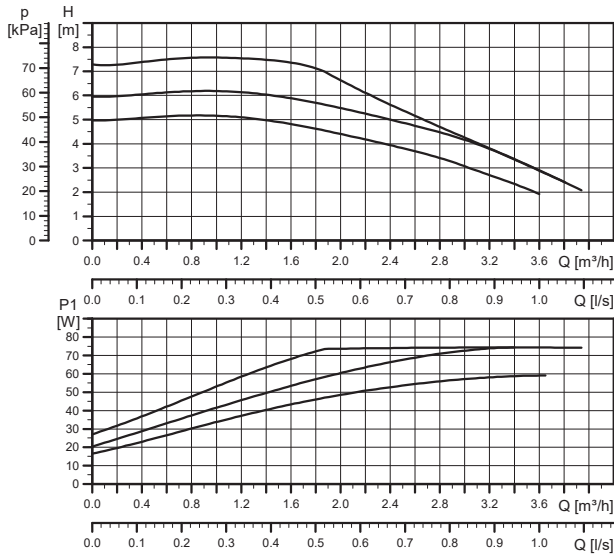

Line type	Description
————	Constant curve
-----	Proportional pressure
- · - · - · -	Constant pressure

EEI ≤ 0.20 Part 3

$P_{L,avg} \leq 32 \text{ W}$

Setting	Max. head _{nom}	Max. P ₁ nom
Curve 1	5 m	60 W
Curve 2	6 m	75 W
Curve 3	7 m	75 W

Pump settings				
PWM A	PWM C	PP	CP	CC
3	3	3/AA	3/AA	3

Electrical data, 1 x 230 V, 50 Hz		
Speed	P ₁ [W]	I _{1/1} [A]
Min.	2	0.04
Max.	75	0.65

Technical data			
System pressure	Max. 1.0 MPa (10 bar)	Enclosure class	IP44 (non-condensing) K: IPX4D (condensing)
Minimum inlet pressure	0.05 MPa (0.50 bar) at 95 °C liquid temperature	Motor protection	No external protection needed
Liquid temperature	2-110 °C (TF110)	Approval and marking	VDE, CE

Dimensions

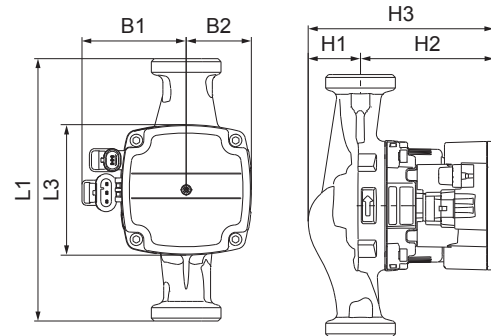

TM063878

Pump type	Dimensions [mm]							Connections [inch]	Weight [kg]
	L1	L3	B1	B2	H1	H2	H3		
15-75 130 (N)	130	90	72	45	36	92	128	R 1/2 / G 1	1.8
25-75 130 (N)	130	90	72	45	36	92	128	R 1 / G 1 1/2	1.9
25-75 180 (N)	180	90	72	45	36	92	128	R 1 / G 1 1/2	2.0
32-75 180 (N)	180	90	72	45	36	92	128	R 1 1/4 / G 2	2.2

For PWM speed curves, see [13.6 UPM3\(K\) XX-50 130/180 \(N\) \(GFNKB\)](#).

UPMO XX-50 130/180, UPMO 60 PH (GFNKB)

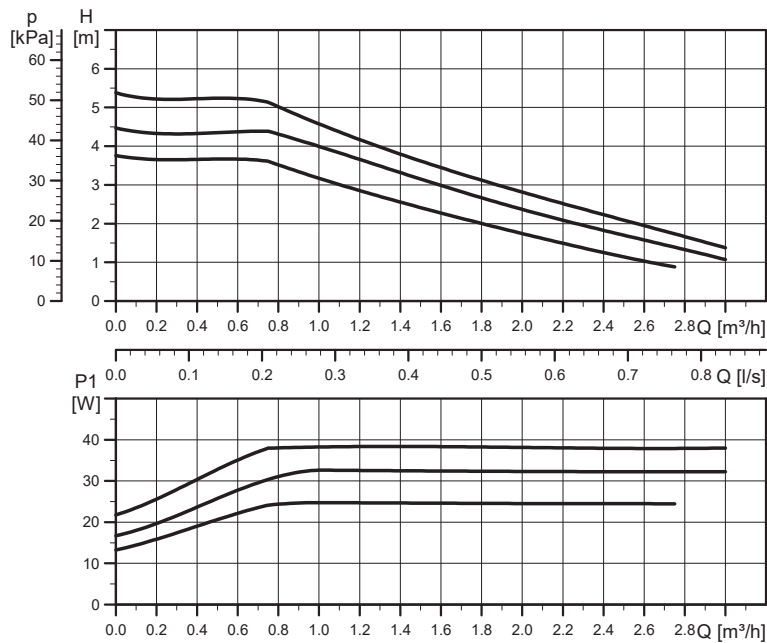

TM075612

EEI ≤ 0.23 Part 3

P_{L,avg} ≤ 20 W

Setting	Max. head _{nom}	Max. P ₁ _{nom}
Curve 1	3.5 m	24 W
Curve 2	4.5 m	32 W
Curve 3	5.5 m	39 W

Pump settings				
PWM A	PWM C	PP	CP	CC
3	-	-	-	3

Electrical data, 1 x 230 V, 50 Hz		
Speed	P ₁ [W]	I _{1/1} [A]
Min.	10	0.11
Max.	39	0.42

Technical data			
System pressure	Max. 1.0 MPa (10 bar)	Enclosure class	IP44 (non-condensing)
Minimum inlet pressure	0.05 MPa (0.50 bar) at 95 °C liquid temperature	Motor protection	No external protection needed
Liquid temperature	2-110 °C (TF110)	Approval and marking	VDE, CE

Dimensions

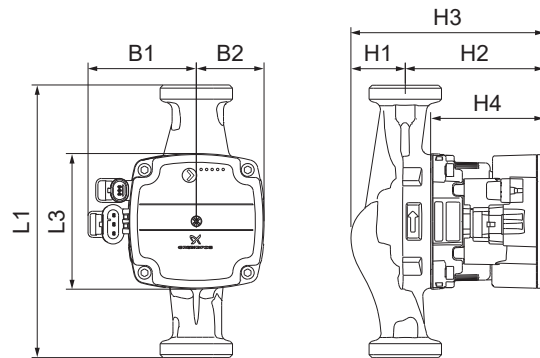

TM070820

Pump type	Dimensions [mm]							Connections [inch]	Weight [kg]	
	L1	L3	B1	B2	H1	H2	H3			H4
15-50 130	130	90	72	47	25.5	102	127.5	-	R 1/2 / G 1	1.8 xx
25-50 130	130	90	72	47	25.5	102	127.5	-	R 1 / G 1 1/2	1.9 xx
25-50 180	180	90	72	47	25.5	102	127.5	-	R 1 / G 1 1/2	2.0 xx
60 PH	-	90	72	47	-	102	-	75.5	-	0.97 xx

For PWM speed curves contact Grundfos HVAC OEM.

UPMO XX-60 130/180, UPMO 60 PH (GFNKB)

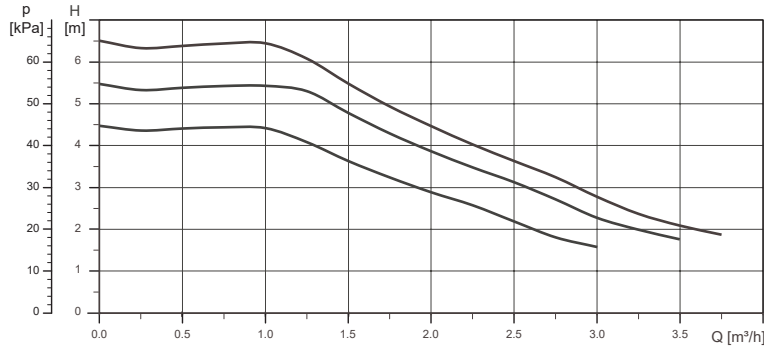

TM071377

EEI ≤ 0.23 Part 3

$P_{L,avg} \leq 25 \text{ W}$

Setting	Max. head $_{nom}$	Max. P_1 $_{nom}$
Curve 1	4.5	32
Curve 2	5.5	39
Curve 3	6.5	52

Pump settings				
PWM A	PWM C	PP	CP	CC
3	-	-	-	3

Electrical data, 1 x 230 V, 50 Hz		
Speed	P_1 [W]	$I_{1/1}$ [A]
Min.	10	0.11
Max.	60	0.58

Technical data			
System pressure	Max. 1.0 MPa (10 bar)	Enclosure class	IP44 (non-condensing)
Minimum inlet pressure	0.05 MPa (0.50 bar) at 95 °C liquid temperature	Motor protection	No external protection needed
Liquid temperature	2-110 °C (TF110)	Approval and marking	VDE, CE

Dimensions

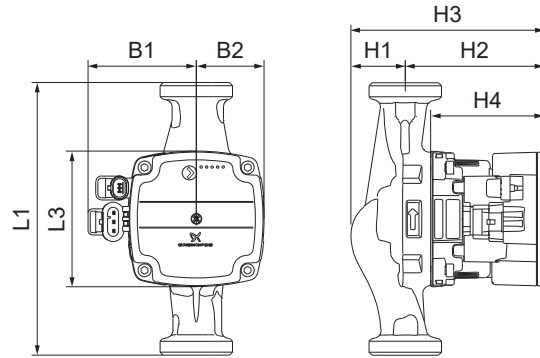

TM070820

Pump type	Dimensions [mm]							Connections [inch]	Weight [kg]	
	L1	L3	B1	B2	H1	H2	H3			H4
15-60 130	130	90	72	47	25.5	102	127.5	-	R 1/2 / G 1	1.8
25-60 130	130	90	72	47	25.5	102	127.5	-	R 1 / G 1 1/2	1.9
25-60 180	180	90	72	47	25.5	102	127.5	-	R 1 / G 1 1/2	2.0
60 PH	-	90	72	47	-	102	-	75.5	-	0.97

For PWM speed curves contact Grundfos HVAC OEM.

UPMO XX-70 130/180, UPMO 60 PH (GFNKC)

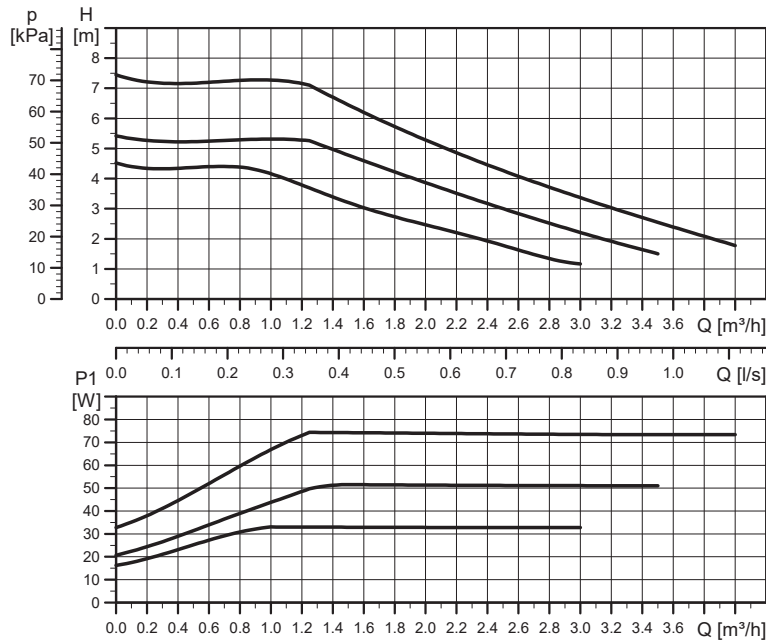

TM075613

EEL ≤ 0.23 Part 3

P_{L,avg} ≤ 30 W

Setting	Max. head nom	Max. P ₁ nom
Curve 1	5 m	32 W
Curve 2	6 m	51 W
Curve 3	7 m	75 W

Pump settings				
PWM A	PWM C	PP	CP	CC
3	-	-	-	3

Electrical data, 1 x 230 V, 50 Hz		
Speed	P ₁ [W]	I _{1/1} [A]
Min.	10	0.11
Max.	75	0.65

Technical data			
System pressure	Max. 1.0 MPa (10 bar)	Enclosure class	IP44 (non-condensing)
Minimum inlet pressure	0.05 MPa (0.50 bar) at 95 °C liquid temperature	Motor protection	No external protection needed
Liquid temperature	2-110 °C (TF110)	Approval and marking	VDE, CE

Dimensions

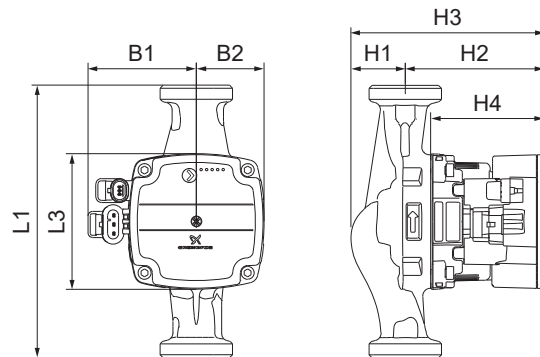

TM070620

Pump type	Dimensions [mm]								Connections [inch]	Weight [kg]
	L1	L3	B1	B2	H1	H2	H3	H4		
15-70 130	130	90	72	47	25.5	102	127.5	-	R 1/2 / G 1	1.8 xx
25-70 130	130	90	72	47	25.5	102	127.5	-	R1 / G 1 1/2	1.9 xx
25-70 180	180	90	72	47	25.5	102	127.5	-	R1 / G 1 1/2	2.0 xx
60 PH	-	90	72	47	-	102	-	75.5	-	0.97 xx

For PWM speed curves contact Grundfos HVAC OEM.

14. Approvals and Certificates

VDE certificate

These pumps are certified by VDE.

Product code for standard variants are GFNHB, GFNKB and GFNKC.

Product code for flammable variants are GFNHF, GFNKG and GFNKH.

The VDE certificate is 40051307.

This Marks Approval forms the basis of the CE declaration of conformity and the CE marking by the manufacturer or his agent and proves the conformity with the essential safety requirements of the EC Low Voltage Directive (2014/35/EU), including amendments.

EurAsia conformity (EAC) certification

These pumps are certified by EAC and can be marked on request.

Drinking water approvals

The pumps for drinking water applications are equipped with stainless-steel or PPS pump housings.

These pumps hold the following approvals:

- ACS (FR)
- WRAS (hot water use) (UK).

The materials in contact with drinking water comply to the applicable evaluation criteria issued by UBA, Germany (hot water use) (DE).

Related information

[Pump housing overview](#)

Grundfos Product Chemical Compliance declaration concerning the non-use of certain chemical substances

Grundfos Holding A/S and its subsidiaries are aware of their responsibilities and are committed not to use hazardous substances in their products.

Grundfos products manufactured and placed on the market within the European Union (EU) and the European Economic Area (EEA) comply with the following EU chemical legislation:

- REACH Regulation (EC 1907/2006).

Candidate List of SVHC:

REACH Annex XIV - Authorisation List

REACH Annex XVII - Restriction List

- REACH Regulation; Candidate List of SVHC, Restriction List and Authorisation List (EC 1907/2006)
- RoHS directives (2011/65/EU and 2015/863/EU)
- Battery directives (2006/66/EC and 493/2012)
- Packaging and Packaging Waste directives (94/62/EC and 2004/12/EC)
- Ozone Depleting Substances directives (EC 1005/2009 and 2037/2000)
- Persistent Organic Pollutants directive (EC 850/2004)
- IMO (International Maritime Organization/Hong Kong Convention)

Today, Grundfos products are not fully covered by the RoHS directives.

The RoHS directives on the restriction of the use of certain hazardous substances in electrical and electronic equipment (EEE) will in 2019 apply to all EEE except for the ones explicitly excluded - see in the position paper from Europump what pumps are considered excluded. Reference is made to the position paper from Europump (<http://europump.net/publications/position-papers>).

Grundfos strives on a voluntary basis to be RoHS-compliant regarding the non-use of certain hazardous substances in Grundfos products.

All suppliers of the raw materials and components to Grundfos Holding A/S and its subsidiaries are under contractual obligation to comply with the European chemical legislation.

To ensure that Grundfos is compliant, we have taken the following initiatives:

- Grundfos has launched the Grundfos Focus List in order to give our suppliers, contractors and other relevant stakeholder worldwide a tool to help comply with chemical legislation. Grundfos has prepared the Grundfos Focus List, which bans or restricts the use of certain chemical substances in Grundfos products, Grundfos production processes and at Grundfos facilities (www.grundfos.com/focus-list)
- Grundfos has implemented an IT-platform to support the work of securing compliance with the Focus List and a better supplier collaboration to secure a high data quality and reliability.
- Grundfos continuously performs audits of their suppliers to ensure compliance with their contractual obligation to comply with the chemical legislation.
- Grundfos does not accept banned or restricted hazardous substances in their products. It is a standard task in product development projects to ensure that banned or restricted hazardous substances are not used.

REACH Regulation (EC 1907/2006)

Information regarding REACH Candidate List of substances of very high concern for Authorisation

At Grundfos, we run our business in a responsible and ever more sustainable way. We are committed to creating products and solutions that help our customers and the surrounding world conserve natural resources and reduce climate impacts.

To give our suppliers, contractors and other relevant stakeholders worldwide a tool to help comply with this, we have devised the Grundfos Focus List, which bans or restricts the use of certain chemical substances in Grundfos products, Grundfos production processes and at Grundfos facilities.

The process set out within Grundfos is to phase out the use of the substances of very high concern (SVHC) from the REACH Candidate List (www.echa.europa.eu/web/guest/candidate-list-table).

With the recent update of the REACH Candidate List of substances of very high concern for Authorisation as of 27.06.2018 where Lead; CAS No. 7439-92-1 has been added, we are making an exemption from our internal procedures, since a timely phaseout is not possible.

Lead is only used in applications that are declared as exemptions in the EU RoHS Directive and the purpose of the RoHS Directive is to eliminate risk of harm:

- copper alloy containing up to 4 % lead by weight (used in fittings, unions etc.)
- lead as an alloying element in aluminium containing up to 0.4 % by weight (used in very few parts)
- lead as an alloying element in steel for machining purposes and in galvanised steel containing up to 0.35 % lead by weight (used in very few parts)
- lead in high-melting-temperature type solders (used electronic components).

At Grundfos, we are working closely together with our suppliers, and all our suppliers are contractually obligated to comply with the Grundfos Focus List, which is our Restricted Substance List: www.grundfos.com/focus-list.

Customer information regarding REACH, RoHS and other relevant chemical legislation and Grundfos' Product Chemical Compliance initiatives

Grundfos Holding A/S and its subsidiaries are aware of their responsibilities and are committed not to use hazardous substances in their products.

We have introduced our Restricted Substance List – the Grundfos Focus List – as the backbone in our product chemical compliance work.

All our suppliers are contractually obligated to comply with the Focus List – independent of the placing of the goods.

To improve the compliance work and to improve the quality process linked to this work, we have also implemented a digital platform to not only secure a far better data quality in our work, but also secure a faster response to our customers in this regard.

The digital platform supports our ISO Management System and secures a robust process with a solid quality performance. All our suppliers are also contractually obliged to sign up to the system and provide compliance data within the system.

We comply with the standard EN 50581:2012 and technically document that we comply with the RoHS directives. This standard is also used in regards of all other legislations listed in the Focus List.

Grundfos continuously performs audits of their suppliers to ensure compliance with their contractual obligation to comply with the chemical legislation.

WEEE Directive 2012/19/EU

Statement regarding compliance of HVAC OEM pumps with WEEE Directive 2012/19/EU

Grundfos HVAC OEM circulators are delivered to OEM customers exclusively as components for integration into heating and cooling units (e.g. boilers) to be used to manufacture the final equipment. As Grundfos HVAC OEM circulators are designed and placed on the market as a component to be integrated into other EEE, the manufacturer of the full/combined product will be responsible for marking, any weight declaring, and takeback obligations for the full combined EEE under directive 2012/19/EU.

Any WEEE obligations will depend on the OEM customers use of the component. It is the responsibility of the OEM customer to assess whether the use of the component is within the scope of directive 2012/19/EU and if this equipment may or may not be affected by WEEE regulation and it is the responsibility of the OEM to report these volumes if affected. Grundfos may – on request – mark HVAC OEM circulators with the WEEE crossed-out wheelee bin, but this does not imply Grundfos taking any WEEE obligations.

Argentina

Bombas GRUNDFOS de Argentina S.A.
Ruta Panamericana km. 37.500 Industin
1619 - Garín Pcia. de B.A.
Tel.: +54-3327 414 444
Fax: +54-3327 45 3190

Australia

GRUNDFOS Pumps Pty. Ltd.
P.O. Box 2040
Regency Park
South Australia 5942
Tel.: +61-8-8461-4611
Fax: +61-8-8340-0155

Austria

GRUNDFOS Pumpen Vertrieb Ges.m.b.H.
Grundfosstraße 2
A-5082 Grödig/Salzburg
Tel.: +43-6246-883-0
Fax: +43-6246-883-30

Belgium

N.V. GRUNDFOS Bellux S.A.
Boomssesteenweg 81-83
B-2630 Aartselaar
Tel.: +32-3-870 7300
Fax: +32-3-870 7301

Belarus

Представительство ГРУНДФОС в
Минске
220125, Минск
ул. Шафарнянская, 11, оф. 56, БЦ
«Порт»
Тел.: +375 17 397 397 3
+375 17 397 397 4
Факс: +375 17 397 397 1
E-mail: minsk@grundfos.com

Bosnia and Herzegovina

GRUNDFOS Sarajevo
Zmajica od Bosne 7-7A
BiH-71000 Sarajevo
Tel.: +387 33 592 480
Fax: +387 33 590 465
www.ba.grundfos.com
E-mail: grundfos@bih.net.ba

Brazil

BOMBAS GRUNDFOS DO BRASIL
Av. Humberto de Alencar Castelo Branco,
630
CEP 09850 - 300
São Bernardo do Campo - SP
Tel.: +55-11 4393 5533
Fax: +55-11 4343 5015

Bulgaria

Grundfos Bulgaria EOOD
Slatina District
Iztochna Tangenta street no. 100
BG - 1592 Sofia
Tel.: +359 2 49 22 200
Fax: +359 2 49 22 201
E-mail: bulgaria@grundfos.bg

Canada

GRUNDFOS Canada inc.
2941 Brighton Road
Oakville, Ontario
L6H 6C9
Tel.: +1-905 829 9533
Fax: +1-905 829 9512

China

GRUNDFOS Pumps (Shanghai) Co. Ltd.
10F The Hub, No. 33 Suhong Road
Minhang District
Shanghai 201106 PRC
Tel.: +86 21 612 252 22
Fax: +86 21 612 253 33

Columbia

GRUNDFOS Colombia S.A.S.
Km 1.5 via Siberia-Cota Conj. Potrero
Chico,
Parque Empresarial Arcos de Cota Bod.
1A.
Cota, Cundinamarca
Tel.: +57(1)-2913444
Fax: +57(1)-8764586

Croatia

GRUNDFOS CROATIA d.o.o.
Buzinski prilaz 38, Buzin
HR-10010 Zagreb
Tel.: +385 1 6595 400
Fax: +385 1 6595 499
www.hr.grundfos.com

Czech Republic

GRUNDFOS Sales Czechia and Slovakia
s.r.o.
Čajkovského 21
779 00 Olomouc
Tel.: +420-585-716 111

Denmark

GRUNDFOS DK A/S
Martin Bachs Vej 3
DK-8850 Bjerringbro
Tel.: +45-87 50 50 50
Fax: +45-87 50 51 51
E-mail: info_GDK@grundfos.com
www.grundfos.com/DK

Estonia

GRUNDFOS Pumps Eesti OÜ
Peterburi tee 92G
11415 Tallinn
Tel.: +372 606 1690
Fax: +372 606 1691

Finland

OY GRUNDFOS Pumput AB
Trukkikuja 1
FI-01360 Vantaa
Tel.: +358-(0) 207 889 500

France

Pompes GRUNDFOS Distribution S.A.
Parc d'Activités de Chesnes
57, rue de Malacombes
F-38290 St. Quentin Fallavier (Lyon)
Tel.: +33-4 74 82 15 15
Fax: +33-4 74 94 10 51

Germany

GRUNDFOS GMBH
Schlüterstr. 33
40699 Erkrath
Tel.: +49-(0) 211 929 69-0
Fax: +49-(0) 211 929 69-3799
E-mail: infoservice@grundfos.de
Service in Deutschland:
kundendienst@grundfos.de

Greece

GRUNDFOS Hellas A.E.B.E.
20th km. Athinon-Markopoulou Av.
P.O. Box 71
GR-19002 Peania
Tel.: +0030-210-66 83 400
Fax: +0030-210-66 46 273

Hong Kong

GRUNDFOS Pumps (Hong Kong) Ltd.
Unit 1, Ground floor, Siu Wai Industrial
Centre
29-33 Wing Hong Street & 68 King Lam
Street, Cheung Sha Wan
Kowloon
Tel.: +852-27861706 / 27861741
Fax: +852-27858664

Hungary

GRUNDFOS Hungária Kft.
Tópark u. 8
H-2045 Törökbálint
Tel.: +36-23 511 110
Fax: +36-23 511 111

India

GRUNDFOS Pumps India Private Limited
118 Old Mahabalipuram Road
Thoraipakkam
Chennai 600 097
Tel.: +91-44 2496 6800

Indonesia

PT GRUNDFOS Pompa
Graha intrub Lt. 2 & 3
Jln. Cililitan Besar No.454. Makasar,
Jakarta Timur
ID-Jakarta 13650
Tel.: +62 21-469-51900
Fax: +62 21-460 6910 / 460 6901

Ireland

GRUNDFOS (Ireland) Ltd.
Unit A, Merrywell Business Park
Ballymount Road Lower
Dublin 12
Tel.: +353-1-4089 800
Fax: +353-1-4089 830

Italy

GRUNDFOS Pompe Italia S.r.l.
Via Gran Sasso 4
I-20060 Truccazzano (Milano)
Tel.: +39-02-95838112
Fax: +39-02-95309290 / 95838461

Japan

GRUNDFOS Pumps K.K.
1-2-3, Shin-Miyakoda, Kita-ku
Hamamatsu
431-2103 Japan
Tel.: +81 53 428 4760
Fax: +81 53 428 5005

Korea

GRUNDFOS Pumps Korea Ltd.
6th Floor, Aju Building 679-5
Yeoksam-dong, Kangnam-ku, 135-916
Seoul, Korea
Tel.: +82-2-5317 600
Fax: +82-2-5633 725

Latvia

SIA GRUNDFOS Pumps Latvia
Deglava biznesa centrs
Augusta Deglava ielā 60
LV-1035, Rīga,
Tel.: +371 714 9640, 7 149 641
Fax: +371 914 9646

Lithuania

GRUNDFOS Pumps UAB
Smolensko g. 6
LT-03201 Vilnius
Tel.: +370 52 395 430
Fax: +370 52 395 431

Malaysia

GRUNDFOS Pumps Sdn. Bhd.
7 Jalan Peguam U1/25
Glenmarie industrial Park
40150 Shah Alam, Selangor
Tel.: +60-3-5569 2922
Fax: +60-3-5569 2866

Mexico

Bombas GRUNDFOS de México
S.A. de C.V.
Boulevard TLC No. 15
Parque industrial Stiva Aeropuerto
Apodaca, N.L. 66600
Tel.: +52-81-8144 4000
Fax: +52-81-8144 4010

Netherlands

GRUNDFOS Netherlands
Veluwezoom 35
1326 AE Almere
Postbus 22015
1302 CA ALMERE
Tel.: +31-88-478 6336
Fax: +31-88-478 6332
E-mail: info_gnl@grundfos.com

New Zealand

GRUNDFOS Pumps NZ Ltd.
17 Beatrice Tinsley Crescent
North Harbour Industrial Estate
Albany, Auckland
Tel.: +64-9-415 3240
Fax: +64-9-415 3250

Norway

GRUNDFOS Pumper A/S
Stramsveien 344
Postboks 235, Leirdal
N-1011 Oslo
Tel.: +47-22 90 47 00
Fax: +47-22 32 21 50

Poland

GRUNDFOS Pompy Sp. z o.o.
ul. Klonowa 23
Baranowo k. Poznania
PL-62-081 Przemierowo
Tel.: (+48-61) 650 13 00
Fax: (+48-61) 650 13 50

Portugal

Bombas GRUNDFOS Portugal, S.A.
Rua Calvet de Magalhães, 241
Apartado 1079
P-2770-153 Paço de Arcos
Tel.: +351-21-440 76 00
Fax: +351-21-440 76 90

Romania

GRUNDFOS Pompe România SRL
S-PARK BUSINESS CENTER, Clădirea
A2, etaj 2
Str. Tipografilor, Nr. 11-15, Sector 1, Cod
013714
Bucuresti, Romania
Tel.: 004 021 2004 100
E-mail: romania@grundfos.ro

Russia

ООО Грундфос Россия
ул. Школьная, 39-41
Москва, RU-109544, Russia
Тел. (+7) 495 564-88-00 (495) 737-30-00
Факс (+7) 495 564 8811
E-mail grundfos.moscow@grundfos.com

Serbia

Grundfos Srbija d.o.o.
Omladinskih brigada 90b
11070 Novi Beograd
Tel.: +381 11 2258 740
Fax: +381 11 2281 769
www.rs.grundfos.com

Singapore

GRUNDFOS (Singapore) Pte. Ltd.
25 Jalan Tukang
Singapore 619264
Tel.: +65-6681 9688
Fax: +65-6681 9689

Slovakia

GRUNDFOS s.r.o.
Prievozská 4D 821 09 BRATISLAVA
Tel.: +421 2 5020 1426
sk.grundfos.com

Slovenia

GRUNDFOS LJUBLJANA, d.o.o.
Leskoškova 9e, 1122 Ljubljana
Tel.: +386 (0) 1 568 06 10
Fax: +386 (0) 1 568 06 19
E-mail: tehniko-si@grundfos.com

South Africa

GRUNDFOS (PTY) LTD
16 Lascelles Drive, Meadowbrook Estate
1609 Germiston, Johannesburg
Tel.: (+27) 10 248 6000
Fax: (+27) 10 248 6002
E-mail: lgradidge@grundfos.com

Spain

Bombas GRUNDFOS España S.A.
Camino de la Fuenteclilla, s/n
E-28110 Algete (Madrid)
Tel.: +34-91-848 8800
Fax: +34-91-628 0465

Sweden

GRUNDFOS AB
Box 333 (Lunnagårdsgatan 6)
431 24 Mölndal
Tel.: +46 31 332 23 000
Fax: +46 31 331 94 60

Switzerland

GRUNDFOS Pumpen AG
Bruggacherstrasse 10
CH-8117 Fällanden/ZH
Tel.: +41-44-806 8111
Fax: +41-44-806 8115

Taiwan

GRUNDFOS Pumps (Taiwan) Ltd.
7 Floor, 219 Min-Chuan Road
Taichung, Taiwan, R.O.C.
Tel.: +886-4-2305 0868
Fax: +886-4-2305 0878

Thailand

GRUNDFOS (Thailand) Ltd.
92 Chaloeam Phrakiat Rama 9 Road
Dokmai, Pravej, Bangkok 10250
Tel.: +66-2-725 8999
Fax: +66-2-725 8998

Turkey

GRUNDFOS POMPA San. ve Tic. Ltd. Sti.
Gebze Organize Sanayi Bölgesi
Ihsan dede Caddesi
2. yol 200. Sokak No. 204
41490 Gebze/ Kocaeli
Tel.: +90 - 262-679 7979
Fax: +90 - 262-679 7905
E-mail: satis@grundfos.com

Ukraine

Бізнес Центр Європа
Столичне шосе, 103
м. Київ, 03131, Україна
Tel.: (+38 044) 237 04 00
Fax: (+38 044) 237 04 01
E-mail: ukraine@grundfos.com

United Arab Emirates

GRUNDFOS Gulf Distribution
P.O. Box 16768
Jebel Ali Free Zone, Dubai
Tel.: +971 4 8815 166
Fax: +971 4 8815 136

United Kingdom

GRUNDFOS Pumps Ltd.
Grovebury Road
Leighton Buzzard/Beds. LU7 4TL
Tel.: +44-1525-850000
Fax: +44-1525-850011

U.S.A.

GRUNDFOS Water Utility Headquarters
856 Koomey Road
Brookshire, Texas 77423 USA

Uzbekistan

Grundfos Tashkent, Uzbekistan
The Representative Office of Grundfos
Kazakhstan in Uzbekistan
38a, Oybek street, Tashkent
Tel.: (+998) 71 150 3290 / 71 150 3291
Fax: (+998) 71 150 3292

98644852 07.2021
ECM: 1318418

GRUNDFOS 

Trademarks displayed in this material, including but not limited to Grundfos, the Grundfos logo and "be think innovate" are registered trademarks owned by The Grundfos Group. All rights reserved. © 2021 Grundfos Holding AS, all rights reserved.