

SH Series

CENTRIFUGAL ELECTRIC PUMPS MADE OF AISI 316 STAINLESS STEEL
IN COMPLIANCE WITH EN 733

ErP 2009/125/EC

**SH SERIES
HYDRAULIC PERFORMANCE RANGE AT 50 Hz**

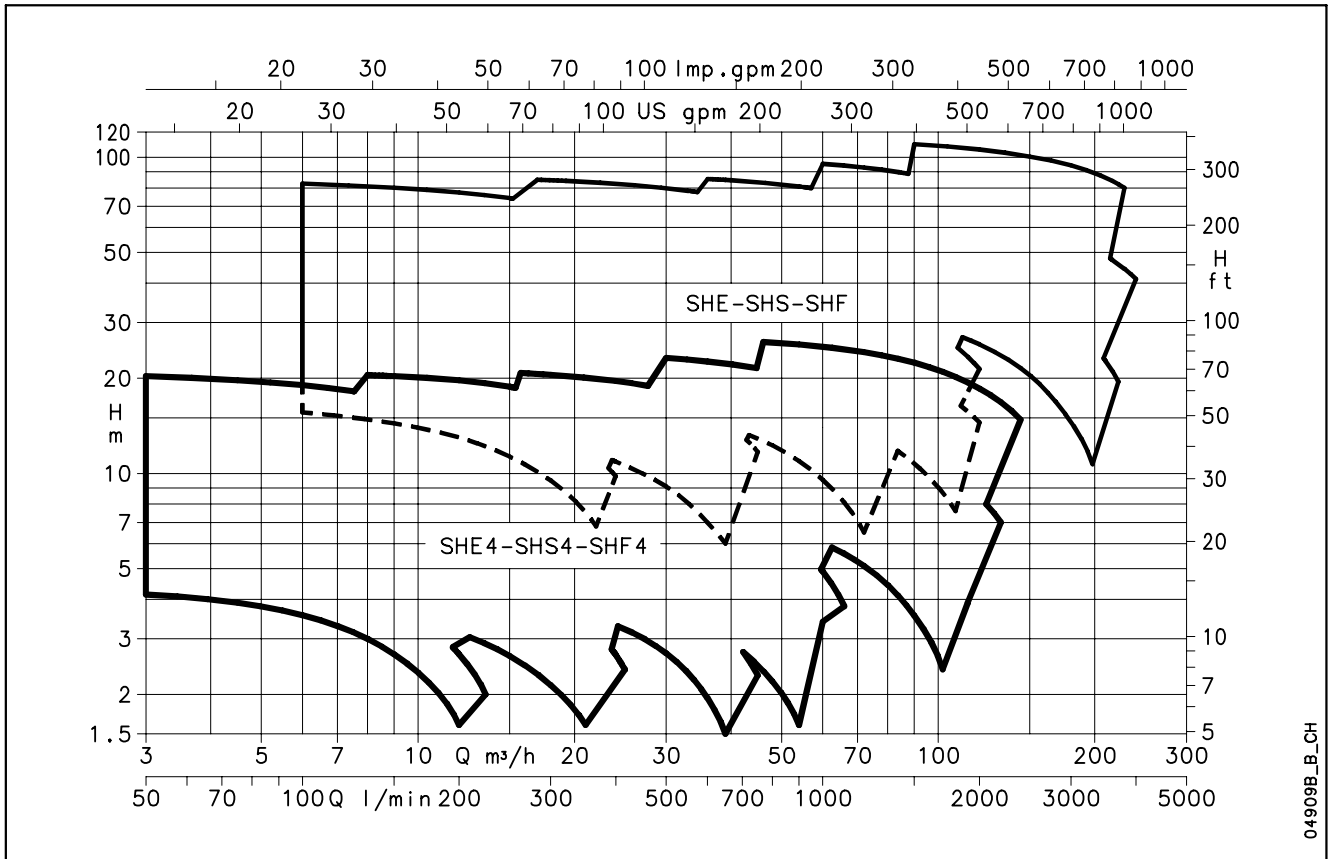

04909B_B_CH

Lowara is a trademark of Lowara srl Unipersonale, subsidiary of Xylem Inc.
HYDROVAR is a trademark of Fluid Handling LLC, subsidiary of Xylem Inc.
Xylect is a trademark of Xylem Water Solutions AB, subsidiary of Xylem Inc.

CONTENTS

Specifications	5
Construction Characteristics	6
List of Models at 50 Hz, 2 and 4 poles	9
Electric pump cross section and main components	10
Mechanical seals	15
Motors (ErP 2009/125/EC).....	16
Pumps (ErP 2009/125/EC).....	25
Hydraulic performance at 50 Hz	26
Table of hydraulic performances at 50 Hz	28
Operating characteristics at 50 Hz, 2 poles	33
Operating characteristics at 50 Hz, 4 poles	56
Dimensions and weights	79
Accessories	97
Technical appendix	103

Centrifugal electric pumps in compliance with EN 733 made of AISI 316 stainless steel

SH Series

MARKET SECTORS

CIVIL, INDUSTRIAL.

APPLICATIONS

- Handling water and clean, chemically non-aggressive or moderately aggressive fluids.
- Water supply and pressure boosting.
- Water circulation in air conditioning systems.
- Washing systems.
- Industry.

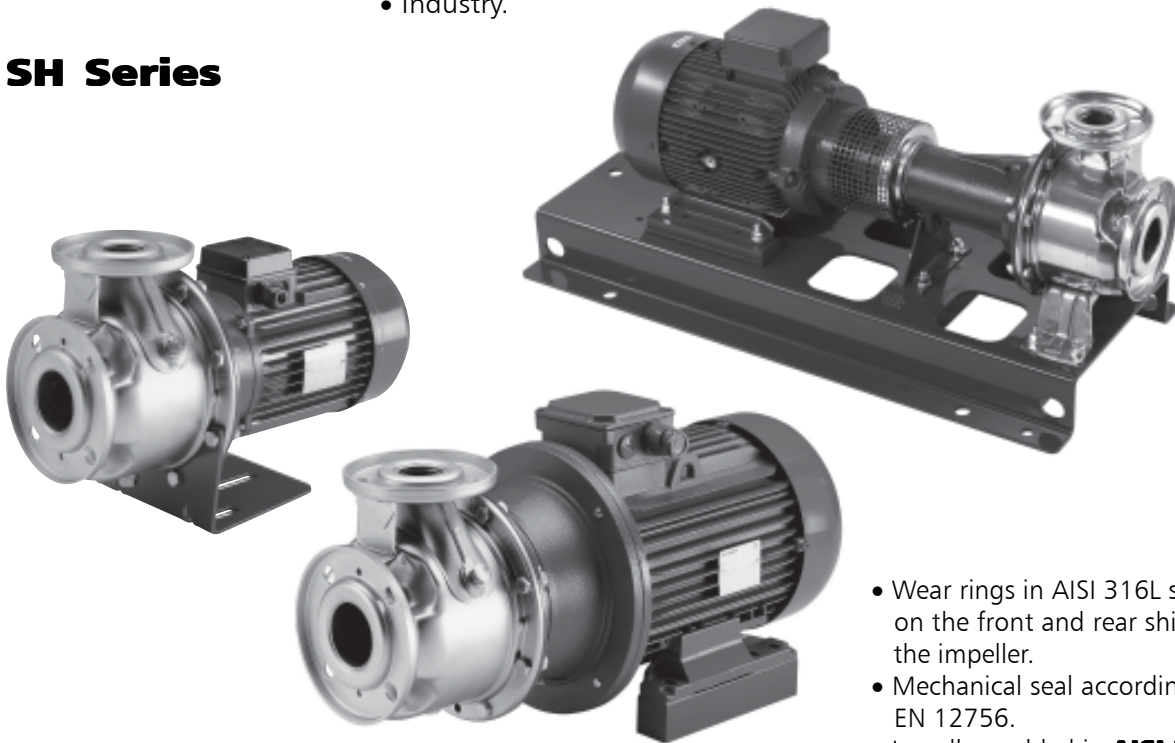

- Wear rings in AISI 316L stainless steel on the front and rear shim washers of the impeller.
- Mechanical seal according to EN 12756.
- Impeller welded in **AISI 316L** stainless steel with laser technology for SH 32, 40, 50, 65-160 (../40, ../55, ../75, ../05, ../07, ../11A); cast in **AISI 316** stainless steel for SH 65-160 (../92, ../110A, ../110, ../11, ../15), 65-200, 65-250, 80.

SPECIFICATIONS

PUMP

- Delivery up to:
240 m³/h for 2-pole range.
130 m³/h for 4-pole range.
- Head up to:
110 metri for 2-pole range.
23 metri for 4-pole range.
- Temperature of pumped liquid:
from -10°C to +120°C for standard version (gaskets in FPM).
from -30°C to +120°C for special version on request (gaskets in EPDM).
- Maximum operating **pressure**:
12 bar (PN 12) at 50°C, 10 bar at 120°C.
- Hydraulic performance compliant with ISO 9906:2012 - Grade 3B (ex ISO 9906:1999 - Annex A).
- Anti-clockwise rotation when facing pump's suction port.

MOTOR

- Squirrel cage in short circuit enclosed construction with external ventilation.
- IP55 protection.
- Class 155 (F) insulation.
- Performances according to EN 60034-1.
- Standard voltage:
 - Single-phase version:
220-240 V, 50 Hz.
 - Three-phase version:
220-240/380-415 V, 50 Hz for power up to 3 kW,
380-415/660-690 V, 50 Hz for power above 3 kW.

CONSTRUCTION CHARACTERISTICS

- Stainless steel centrifugal pump with end suction and radial discharge ports.
- Hydraulic sizes and nominal diameter of suction and discharge ports according to EN 733 (except for SH 25).
- Flanges according to EN 1092-2.
- Back pull-out design (impeller, bracket and motor can be extracted without disconnecting the pump body from the piping).

MOTOR-PUMP COUPLING

Three different motor-pump couplings are available:

- **SHE:** Close-coupled version with rotor directly splined onto the motor shaft protrusion and special coupling joint. The variant with single-phase motor (FHEM) is available for some models.
- **SHS:** Close-coupled version with rotor directly splined onto the rigid coupling connected to the shaft protrusion of a standardised motor, joint and coupling adapter.
- **SHF:** Version with rotor directly splined onto the rigid coupling connected to the shaft protrusion of a standardised motor by means of a flexible coupling, joint, coupling support with bearings, alignment base and anchor system.

Just the bare shaft pump is available on request.

The variant with elastic coupling and spacer (SHF..SC) is available.

ACCESSORIES ON REQUEST

- Counter-flanges in galvanised steel or AISI 316 stainless steel and gaskets.
- Shims for pump and motor feet.

OPTIONAL FEATURES

- Different voltages.
- Frequency 60 Hz (see specific catalogue).
- Tropicalised motors.
- Special materials for mechanical seal and gaskets.
- Mechanical seal with anti-rotation locking ring.
- Mechanical seal internal flush tube.
- Mechanical seal external flush connector.
- Elastic coupling with spacer (SHF..SC).
- Pumps with diesel engine.
- Electric pumps with HYDROVAR™ control system.
- Pumps (SHF) and electric pumps (SHS, SHF) compliant with ATEX 94/9/CE for Group II, Category 3, Gas atmosphere (IIBG

SHE – SHE4

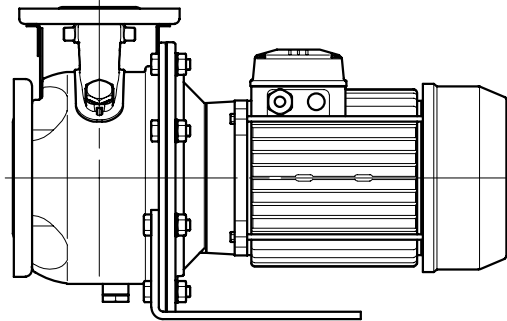

SHS – SHS4

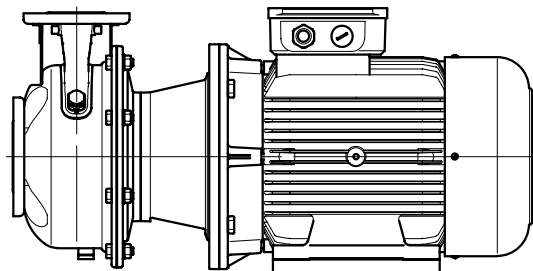

SHF – SHF4

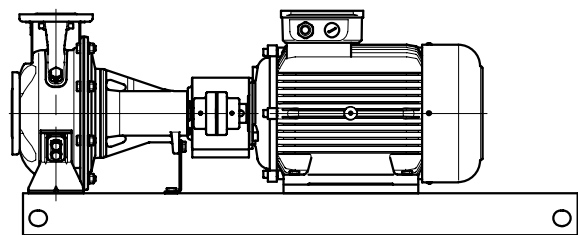

04905_A_SC

SH SERIES IDENTIFICATION CODE

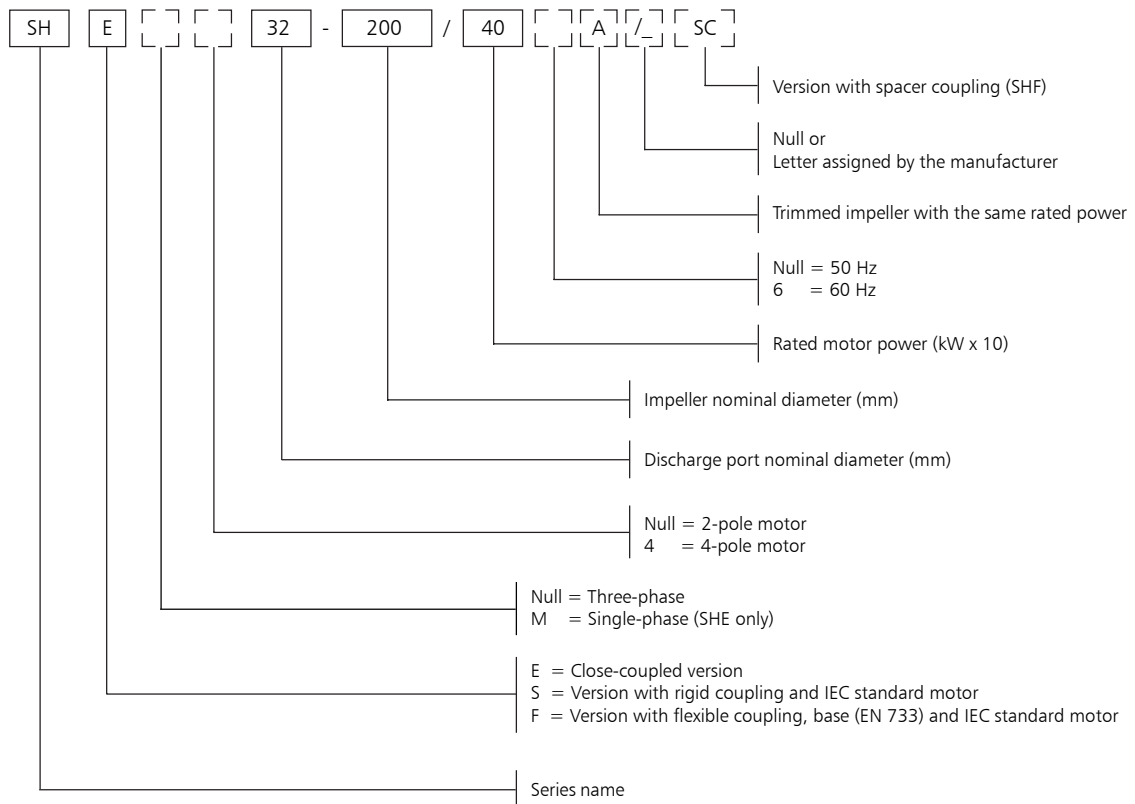

EXAMPLES:

SHF 65-200/220/C SC

Series SH electric pump, stainless steel impeller, version with base, three-phase, DN 65 discharge port, impeller nominal diameter 200 mm, rated motor power 22 kW, frequency 50 Hz, elastic coupling with spacer.

SHF 65-200/215

Series SH pump with bare shaft, stainless steel impeller, version with base, DN 65 discharge port, impeller nominal diameter 200 mm, impeller effective diameter 215 mm, frequency 50 Hz.

RATING PLATE SHE - SHS (ELECTRIC PUMP)

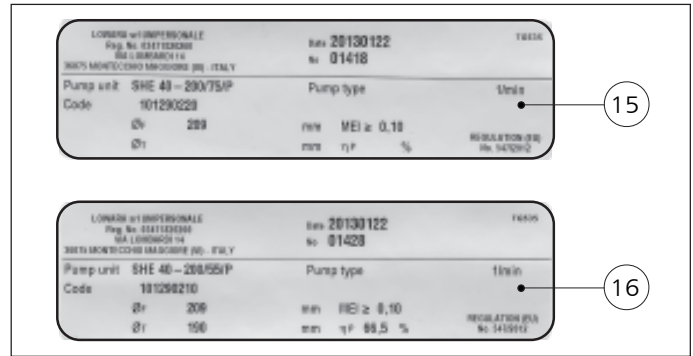
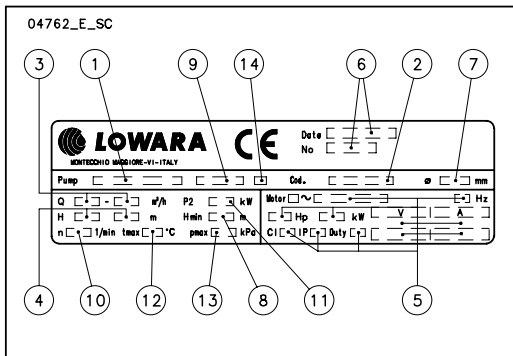

SHF (PUMP ONLY)

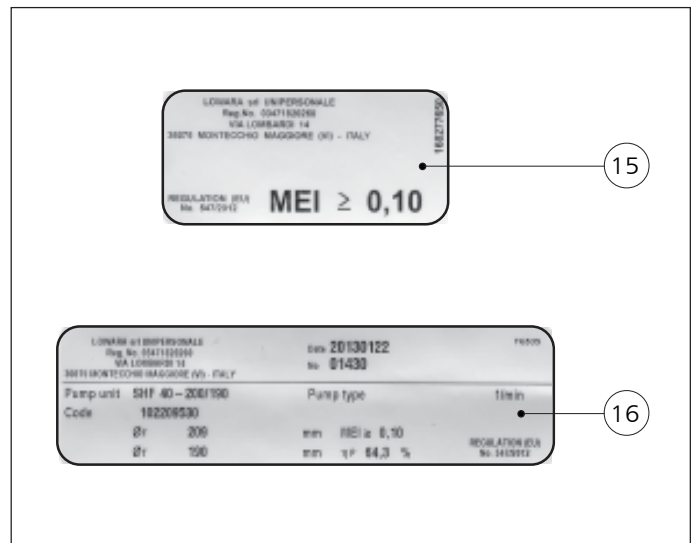
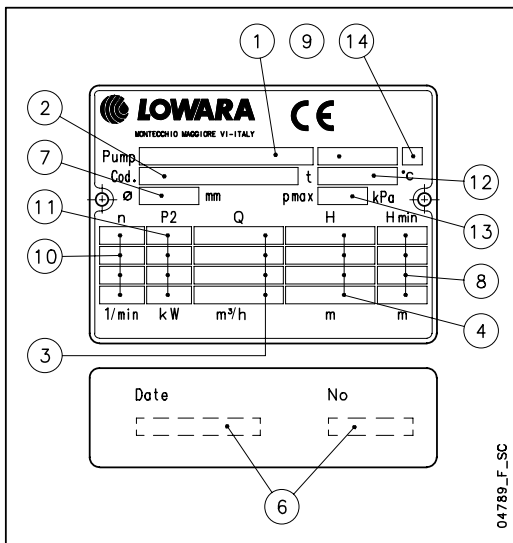

SHF (ELECTRIC PUMP)

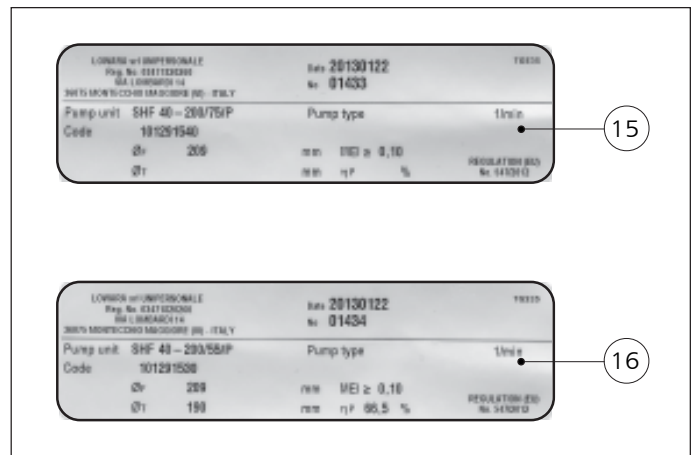
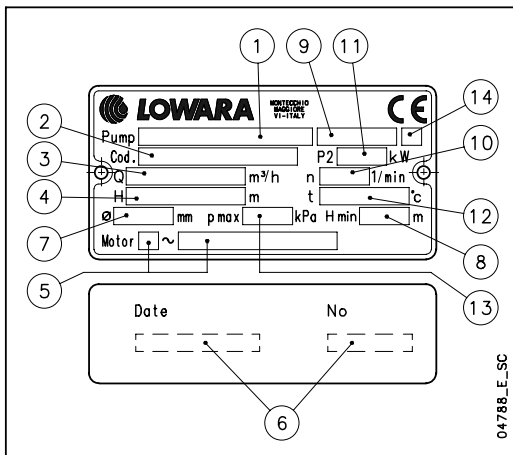

LEGEND

- 1 - Pump / electric pump unit type
- 2 - Electric pump unit / pump part number
- 3 - Capacity range
- 4 - Head range
- 5 - Motor type
- 6 - Serial number (date + progressive number)
- 7 - Impeller diameter
- 8 - Minimum head (EN 60335-2-41)
- 9 - Mechanical seal material identification code

- 10 - Speed
- 11 - Rated power
- 12 - Maximum operating temperature
- 13 - Maximum operating pressure
- 14 - O-ring material identification code
- 15 - MEI label (Regulation (EU) n. 547/2012) for model with full impeller
- 16 - MEI label (Regulation (EU) n. 547/2012) for model with trimmed impeller

SH SERIES LIST OF MODELS AT 50 Hz, 2 POLES

SIZE	kW	VERSION				
		SHEM	SHE	SHS	SHF	SHF..SC
25-125/07	0,75	•	•	•	•	-
25-125/11	1,1	•	•	•	•	-
25-160/15	1,5	•	•	•	•	-
25-160/22	2,2	•	•	•	•	-
25-200/30	3	-	•	•	•	-
25-200/40	4	-	•	•	•	-
25-250/55	5,5	-	•	•	•	-
25-250/75	7,5	-	•	•	•	-
25-250/110	11	-	•	•	•	-
32-125/07	0,75	•	•	•	•	•
32-125/11	1,1	•	•	•	•	•
32-160/15	1,5	•	•	•	•	•
32-160/22	2,2	•	•	•	•	•
32-200/30	3	-	•	•	•	•
32-200/40	4	-	•	•	•	•
32-250/55	5,5	-	•	•	•	•
32-250/75	7,5	-	•	•	•	•
32-250/110	11	-	•	•	•	•
40-125/11	1,1	•	•	•	•	•
40-125/15	1,5	•	•	•	•	•
40-125/22	2,2	•	•	•	•	•
40-160/30	3	-	•	•	•	•
40-160/40	4	-	•	•	•	•
40-200/55	5,5	-	•	•	•	•
40-200/75	7,5	-	•	•	•	•
40-250/92	9,2	-	•	-	-	-
40-250/110A	11	-	-	•	•	•
40-250/110	11	-	•	•	•	•
40-250/150	15	-	•	•	•	•
50-125/22	2,2	•	•	•	•	•
50-125/30	3	-	•	•	•	•
50-125/40	4	-	•	•	•	•
50-160/55	5,5	-	•	•	•	•
50-160/75	7,5	-	•	•	•	•
50-200/92	9,2	-	•	-	-	-
50-200/110A	11	-	-	•	•	•
50-200/110	11	-	•	•	•	•
50-250/150	15	-	•	•	•	•
50-250/185	18,5	-	•	•	•	•
50-250/220	22	-	•	•	•	•
65-160/40	4	-	•	•	•	•
65-160/55	5,5	-	•	•	•	•
65-160/75	7,5	-	•	•	•	•
65-160/92	9,2	-	•	-	-	-
65-160/110A	11	-	-	•	•	•
65-160/110	11	-	•	•	•	•
65-200/150	15	-	•	•	•	•
65-200/185	18,5	-	•	•	•	•
65-200/220	22	-	•	•	•	•
65-250/300	30	-	-	•	•	•
65-250/370	37	-	-	•	•	•
80-160/110	11	-	•	•	•	•
80-160/150	15	-	•	•	•	•
80-160/185	18,5	-	•	•	•	•
80-200/220	22	-	•	•	•	•
80-200/300	30	-	-	•	•	•
80-200/370	37	-	-	•	•	•
80-250/450	45	-	-	-	•	•
80-250/550	55	-	-	-	•	•
80-250/750	75	-	-	-	•	•

• = Available

she-shs-shf_2p50-en_c_tem

4 POLES

SIZE	kW	VERSION			
		SHE4	SHS4	SHF4	SHF4..SC
25-125/02A	0,25	•	-	•	-
25-125/02	0,25	•	-	•	-
25-160/02	0,25	•	-	•	-
25-160/03	0,37	•	-	•	-
25-200/03	0,37	•	-	•	-
25-200/05	0,55	•	-	•	-
25-250/07	0,75	•	•	•	-
25-250/11	1,1	•	•	•	-
25-250/15	1,5	•	•	•	-
32-125/02A	0,25	•	-	•	-
32-125/02	0,25	•	-	•	-
32-160/02	0,25	•	-	•	-
32-160/03	0,37	•	-	•	-
32-200/03	0,37	•	-	•	-
32-200/05	0,55	•	-	•	-
32-250/07	0,75	•	•	•	-
32-250/11	1,1	•	•	•	-
32-250/15	1,5	•	•	•	-
40-125/02A	0,25	•	-	•	-
40-125/02	0,25	•	-	•	-
40-125/03	0,37	•	-	•	-
40-160/03	0,37	•	-	•	-
40-160/05	0,5	•	-	•	-
40-200/07	0,75	•	•	•	-
40-200/11	1,1	•	•	•	-
40-250/11	1,1	•	•	•	-
40-250/15	1,5	•	•	•	-
40-250/22	2,2	•	•	•	-
50-125/03A	0,37	•	-	•	-
50-125/03	0,37	•	-	•	-
50-125/05	0,5	•	-	•	-
50-160/07	0,75	•	•	•	-
50-160/11	1,1	•	•	•	-
50-200/11	1,1	•	•	•	-
50-200/15	1,5	•	•	•	-
50-250/22A	2,2	•	•	•	-
50-250/22	2,2	•	•	•	-
50-250/30	3	•	•	•	-
65-160/05	0,5	•	•	•	-
65-160/07	0,75	•	•	•	-
65-160/11A	1,1	•	•	•	-
65-160/11	1,1	•	•	•	-
65-160/15	1,5	•	•	•	-
65-200/15	1,5	•	•	•	-
65-200/22	2,2	•	•	•	-
65-200/30	3	•	•	•	-
65-250/40	4	•	•	•	-
65-250/55	5,5	•	•	•	-
80-160/15	1,5	•	•	•	-
80-160/22A	2,2	•	•	•	-
80-160/22	2,2	•	•	•	-
80-200/30	3	•	•	•	-
80-200/40	4	•	•	•	-
80-250/55	5,5	•	•	•	-
80-250/75	7,5	•	•	•	-
80-250/110	11	•	•	•	-

• = Available

she4-shs4-shf4_4p50-en_d_tem

LEGEND

SHE : Close-coupled version. **SHEM** : Close-coupled version with single-phase motor.

SHS : Close coupled version with rigid coupling and standardised motor.

SHF : Version with elastic coupling, support, base and standardised motor.

SHF.SC : Version with elastic coupling and spacer, support, base and standardised motor.

SHE - SHE4 SERIES ELECTRIC PUMP CROSS SECTION AND MAIN COMPONENTS

04906_B_DS

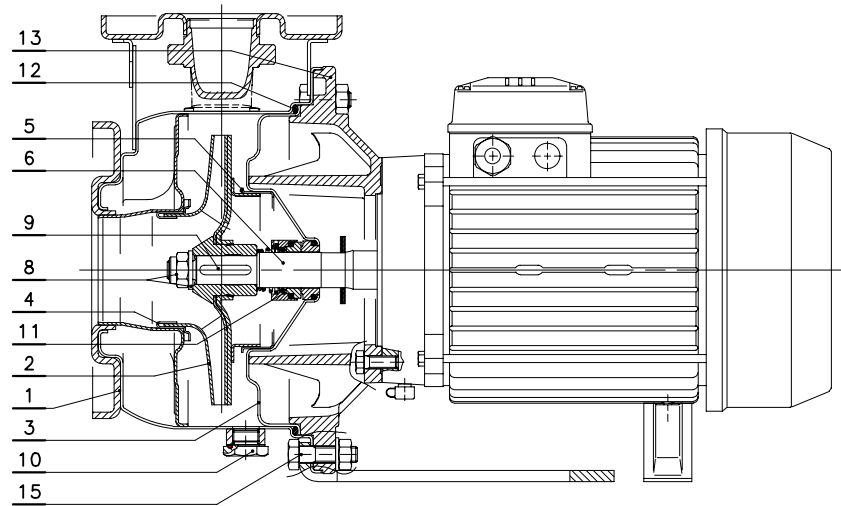

VERSIONS	
2 POLES	4 POLES
SHE 25-125/07	SHE4 25-200/05
SHE 25-125/11	SHE4 25-250/07
SHE 25-160/15	SHE4 25-250/11
SHE 25-160/22	SHE4 25-250/15
SHE 25-200/30	SHE4 32-200/05
SHE 25-200/40	SHE4 32-250/07
SHE 25-250/55	SHE4 32-250/11
SHE 25-250/75	SHE4 32-250/15
SHE 25-250/110	SHE4 40-160/05
SHE 32-125/07	SHE4 40-200/07
SHE 32-125/11	SHE4 40-200/11
SHE 32-160/15	SHE4 40-250/11
SHE 32-160/22	SHE4 40-250/15
SHE 32-200/30	SHE4 40-250/22
SHE 32-200/40	SHE4 50-125/05
SHE 32-250/55	SHE4 50-160/07
SHE 32-250/75	SHE4 50-160/11
SHE 32-250/110	SHE4 50-200/11
SHE 40-125/11	SHE4 50-200/15
SHE 40-125/15	SHE4 50-250/22A
SHE 40-125/22	SHE4 50-250/22
SHE 40-160/30	SHE4 50-250/30
SHE 40-160/40	SHE4 65-160/05
SHE 40-200/55	SHE4 65-160/07
SHE 40-200/75	SHE4 65-160/11A
SHE 40-250/92	SHE4 65-160/11
SHE 40-250/110	SHE4 65-160/15
SHE 50-125/22	SHE4 65-200/15
SHE 50-125/30	SHE4 65-200/22
SHE 50-125/40	SHE4 65-200/30
SHE 50-160/55	SHE4 65-250/40
SHE 50-160/75	SHE4 65-250/55
SHE 50-200/92	SHE4 80-160/15
SHE 50-200/110	SHE4 80-160/22A
SHE 65-160/40	SHE4 80-160/22
SHE 65-160/55	SHE4 80-200/30
SHE 65-160/75	SHE4 80-200/40
SHE 65-160/92	SHE4 80-250/55
SHE 65-160/110	SHE4 80-250/75
SHE 80-160/110	

sh-she-p-en_b_mo

REF. N.	NAME	MATERIAL	REFERENCE STANDARDS	
			EUROPE	USA
1	Pump body	Stainless steel	EN 10088-1-X2CrNiMo17-12-2 (1.4404)	AISI 316L
2	Impeller 25-32-40-50-65(160)**	Stainless steel	EN 10088-1-X2CrNiMo17-12-2 (1.4404)	AISI 316L
	Impeller 65(160)***, 65(200-250)-80	Stainless steel	EN 10213-4-GX5CrNiMo19-11-2 (1.4408)	ASTM CF8M (cast AISI 316)
3	Seal housing	Stainless steel	EN 10088-1-X2CrNiMo17-12-2 (1.4404)	AISI 316L
4	Wear ring	Stainless steel	EN 10088-1-X2CrNiMo17-12-2 (1.4404)	AISI 316L
5	Counterwear ring	Stainless steel	EN 10088-1-X2CrNiMo17-12-2 (1.4404)	AISI 316L
6	Shaft extension	Stainless steel	EN 10088-1-X5CrNiMo17-12-2 (1.4401)	AISI 316
7	Rigid shaft coupling	Stainless steel	EN 10088-1-X5CrNiMo17-12-2 (1.4401)	AISI 316
8	Impeller locknut and washer	Stainless steel	EN 10088-1-X5CrNiMo17-12-2 (1.4401)	AISI 316
9	Tab	Stainless steel	EN 10088-1-X2CrNiMo17-12-2 (1.4404)	AISI 316L
10	Fill/drain plugs	Stainless steel	EN 10088-1-X5CrNiMo17-12-2 (1.4401)	AISI 316
11	Mechanical seal	Ceramic / Carbon / FPM (standard version)		
12	Elastomers	FPM (standard version)		
13	Adapter *	Aluminium	EN 1706-AC-AISI11Cu2 (Fe) (AC46100)	-
	Adapter	Cast iron	EN 1561-GJL-200 (JL1030)	ASTM Class 25
15	Pump body fastening bolts & screws	Galvanized steel		

* 2/4 pole: 25/32/40-125, 25/32/40-160, 25/32/40-200

** 2 pole: 65-160/40, 65-160/55, 65-160/75; 4 pole: 65-160/05, 65-160/07, 65-160/11A

*** 2 pole: 65-160/92, 65-160/110A, 65-160/110; 4 pole: 65-160/11, 65-160/15

SHE - SHE4 SERIES ELECTRIC PUMP CROSS SECTION AND MAIN COMPONENTS

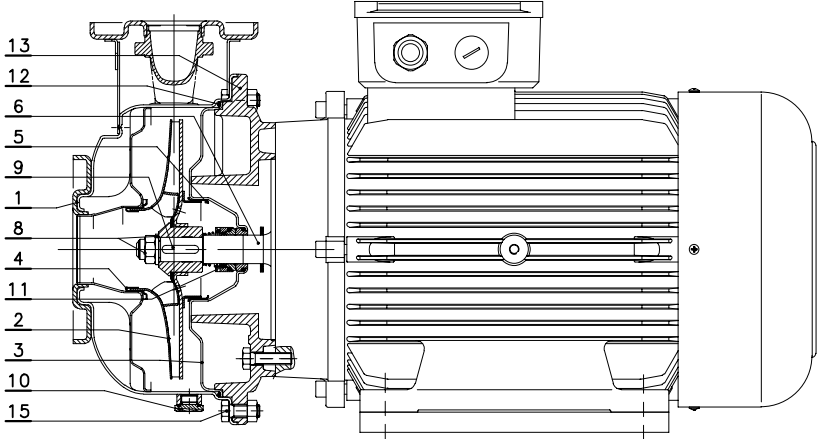
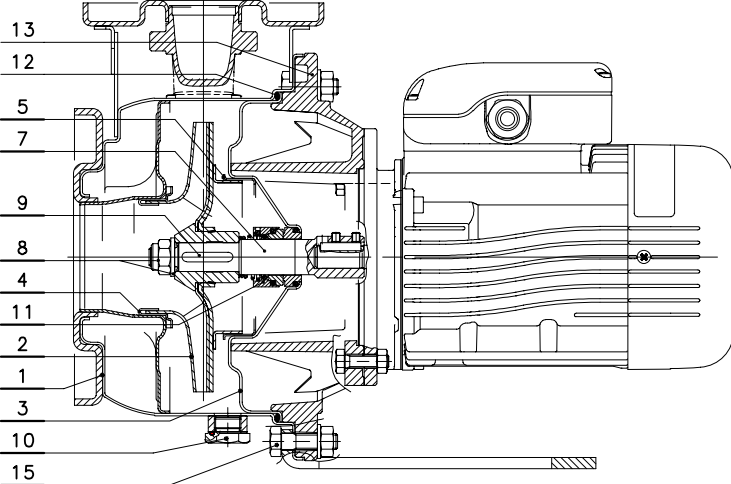
<p>04902_B_DS</p> 	<table border="1" style="width: 100%; border-collapse: collapse; text-align: center;"> <thead> <tr> <th colspan="2">VERSIONS</th> </tr> <tr> <th>2 POLES</th> <th>4 POLES</th> </tr> </thead> <tbody> <tr><td>SHE 40-250/150</td><td>SHE4 80-250/110</td></tr> <tr><td>SHE 50-250/150</td><td></td></tr> <tr><td>SHE 50-250/185</td><td></td></tr> <tr><td>SHE 50-250/220</td><td></td></tr> <tr><td>SHE 65-200/150</td><td></td></tr> <tr><td>SHE 65-200/185</td><td></td></tr> <tr><td>SHE 65-200/220</td><td></td></tr> <tr><td>SHE 80-160/150</td><td></td></tr> <tr><td>SHE 80-160/185</td><td></td></tr> <tr><td>SHE 80-200/220</td><td></td></tr> </tbody> </table> <p style="text-align: right; font-size: small;">sh-she-s-en_b_mo</p>	VERSIONS		2 POLES	4 POLES	SHE 40-250/150	SHE4 80-250/110	SHE 50-250/150		SHE 50-250/185		SHE 50-250/220		SHE 65-200/150		SHE 65-200/185		SHE 65-200/220		SHE 80-160/150		SHE 80-160/185		SHE 80-200/220	
VERSIONS																									
2 POLES	4 POLES																								
SHE 40-250/150	SHE4 80-250/110																								
SHE 50-250/150																									
SHE 50-250/185																									
SHE 50-250/220																									
SHE 65-200/150																									
SHE 65-200/185																									
SHE 65-200/220																									
SHE 80-160/150																									
SHE 80-160/185																									
SHE 80-200/220																									
	<table border="1" style="width: 100%; border-collapse: collapse; text-align: center;"> <thead> <tr> <th colspan="2">VERSIONS</th> </tr> <tr> <th colspan="2">4 POLES</th> </tr> </thead> <tbody> <tr><td>SHE4 25-125/02A</td><td>SHE4 40-125/02A</td></tr> <tr><td>SHE4 25-125/02</td><td>SHE4 40-125/02</td></tr> <tr><td>SHE4 25-160/02</td><td>SHE4 40-125/03</td></tr> <tr><td>SHE4 25-160/03</td><td>SHE4 40-160/03</td></tr> <tr><td>SHE4 25-200/03</td><td>SHE4 50-125/03A</td></tr> <tr><td>SHE4 32-125/02A</td><td>SHE4 50-125/03</td></tr> <tr><td>SHE4 32-125/02</td><td></td></tr> <tr><td>SHE4 32-160/02</td><td></td></tr> <tr><td>SHE4 32-160/03</td><td></td></tr> <tr><td>SHE4 32-200/03</td><td></td></tr> </tbody> </table> <p style="text-align: right; font-size: small;">sh-she4-p-en_a_mo</p>	VERSIONS		4 POLES		SHE4 25-125/02A	SHE4 40-125/02A	SHE4 25-125/02	SHE4 40-125/02	SHE4 25-160/02	SHE4 40-125/03	SHE4 25-160/03	SHE4 40-160/03	SHE4 25-200/03	SHE4 50-125/03A	SHE4 32-125/02A	SHE4 50-125/03	SHE4 32-125/02		SHE4 32-160/02		SHE4 32-160/03		SHE4 32-200/03	
VERSIONS																									
4 POLES																									
SHE4 25-125/02A	SHE4 40-125/02A																								
SHE4 25-125/02	SHE4 40-125/02																								
SHE4 25-160/02	SHE4 40-125/03																								
SHE4 25-160/03	SHE4 40-160/03																								
SHE4 25-200/03	SHE4 50-125/03A																								
SHE4 32-125/02A	SHE4 50-125/03																								
SHE4 32-125/02																									
SHE4 32-160/02																									
SHE4 32-160/03																									
SHE4 32-200/03																									

REF. N.	NAME	MATERIAL	REFERENCE STANDARDS	
			EUROPE	USA
1	Pump body	Stainless steel	EN 10088-1-X2CrNiMo17-12-2 (1.4404)	AISI 316L
2	Impeller 25-32-40-50-65(160)**	Stainless steel	EN 10088-1-X2CrNiMo17-12-2 (1.4404)	AISI 316L
	Impeller 65(160)***, 65(200-250)-80	Stainless steel	EN 10213-4-GX5CrNiMo19-11-2 (1.4408)	ASTM CF8M (cast AISI 316)
3	Seal housing	Stainless steel	EN 10088-1-X2CrNiMo17-12-2 (1.4404)	AISI 316L
4	Wear ring	Stainless steel	EN 10088-1-X2CrNiMo17-12-2 (1.4404)	AISI 316L
5	Counterwear ring	Stainless steel	EN 10088-1-X2CrNiMo17-12-2 (1.4404)	AISI 316L
6	Shaft extension	Stainless steel	EN 10088-1-X5CrNiMo17-12-2 (1.4401)	AISI 316
7	Rigid shaft coupling	Stainless steel	EN 10088-1-X5CrNiMo17-12-2 (1.4401)	AISI 316
8	Impeller locknut and washer	Stainless steel	EN 10088-1-X5CrNiMo17-12-2 (1.4401)	AISI 316
9	Tab	Stainless steel	EN 10088-1-X2CrNiMo17-12-2 (1.4404)	AISI 316L
10	Fill/drain plugs	Stainless steel	EN 10088-1-X5CrNiMo17-12-2 (1.4401)	AISI 316
11	Mechanical seal	Ceramic / Carbon / FPM (standard version)		
12	Elastomers	FPM (standard version)		
13	Adapter *	Aluminium	EN 1706-AC-AISI11Cu2 (Fe) (AC46100)	-
	Adapter	Cast iron	EN 1561-GJL-200 (JL1030)	ASTM Class 25
15	Pump body fastening bolts & screws	Galvanized steel		

* 2/4 pole: 25/32/40-125, 25/32/40-160, 25/32/40-200

sh_she-en_d_tm

** 2 pole: 65-160/40, 65-160/55, 65-160/75; 4 pole: 65-160/05, 65-160/07, 65-160/11A

*** 2 pole: 65-160/92, 65-160/110A, 65-160/110; 4 pole: 65-160/11, 65-160/15

SHS - SHS4 SERIES ELECTRIC PUMP CROSS SECTION AND MAIN COMPONENTS

04956_C_DS

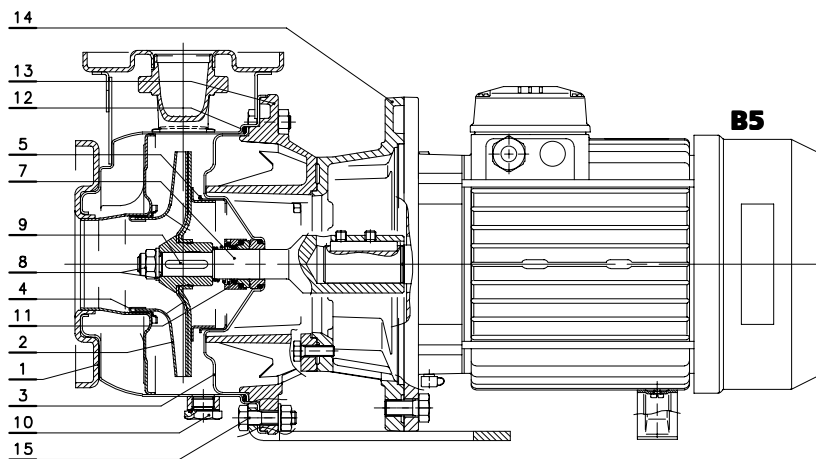

VERSIONS	
2 POLES	4 POLES
SHS 25-125/07	SHS4 25-250/07
SHS 25-125/11	SHS4 25-250/11
SHS 25-160/15	SHS4 25-250/15
SHS 25-160/22	SHS4 32-250/07
SHS 25-200/30	SHS4 32-250/11
SHS 25-200/40	SHS4 32-250/15
SHS 25-250/55	SHS4 40-200/07
SHS 25-250/75	SHS4 40-200/11
SHS 32-125/07	SHS4 40-250/11
SHS 32-125/11	SHS4 40-250/15
SHS 32-160/15	SHS4 40-250/22
SHS 32-160/22	SHS4 50-160/07
SHS 32-200/30	SHS4 50-160/11
SHS 32-200/40	SHS4 50-200/11
SHS 32-250/55	SHS4 50-200/15
SHS 32-250/75	SHS4 50-250/22A
SHS 40-125/11	SHS4 50-250/22
SHS 40-125/15	SHS4 50-250/30
SHS 40-125/22	SHS4 65-160/05
SHS 40-160/30	SHS4 65-160/07
SHS 40-160/40	SHS4 65-160/11A
SHS 40-200/55	SHS4 65-160/11
SHS 40-200/75	SHS4 65-160/15
SHS 50-125/22	SHS4 65-200/15
SHS 50-125/30	SHS4 65-200/22
SHS 50-125/40	SHS4 65-200/30
SHS 50-160/55	SHS4 65-250/40
SHS 50-160/75	SHS4 65-250/55
SHS 65-160/40	SHS4 80-160/15
SHS 65-160/55	SHS4 80-160/22A
SHS 65-160/75	SHS4 80-160/22
	SHS4 80-200/30
	SHS4 80-200/40
	SHS4 80-250/55
	SHS4 80-250/75

sh-shs-p-en_b_mo

REF. N.	NAME	MATERIAL	REFERENCE STANDARDS	
			EUROPE	USA
1	Pump body	Stainless steel	EN 10088-1-X2CrNiMo17-12-2 (1.4404)	AISI 316L
2	Impeller 25-32-40-50-65(160)**	Stainless steel	EN 10088-1-X2CrNiMo17-12-2 (1.4404)	AISI 316L
	Impeller 65(160)***, 65(200-250)-80	Stainless steel	EN 10213-4-GX5CrNiMo19-11-2 (1.4408)	ASTM CF8M (cast AISI 316)
3	Seal housing	Stainless steel	EN 10088-1-X2CrNiMo17-12-2 (1.4404)	AISI 316L
4	Wear ring	Stainless steel	EN 10088-1-X2CrNiMo17-12-2 (1.4404)	AISI 316L
5	Counterwear ring	Stainless steel	EN 10088-1-X2CrNiMo17-12-2 (1.4404)	AISI 316L
7	Rigid shaft coupling	Stainless steel	EN 10088-1-X5CrNiMo17-12-2 (1.4401)	AISI 316
8	Impeller locknut and washer	Stainless steel	EN 10088-1-X5CrNiMo17-12-2 (1.4401)	AISI 316
9	Tab	Acciaio inox	EN 10088-1-X2CrNiMo17-12-2 (1.4404)	AISI 316L
10	Fill/drain plugs	Stainless steel	EN 10088-1-X5CrNiMo17-12-2 (1.4401)	AISI 316
11	Mechanical seal	Ceramic / Carbon / FPM (standard version)		
12	Elastomers	FPM (standard version)		
13	Adapter *	Aluminium	EN 1706-AC-AISI11Cu2 (Fe) (AC46100)	-
	Adapter	Cast iron	EN 1561-GJL-200 (JL1030)	ASTM Class 25
14	Adapter motor coupling	Cast iron	EN 1561-GJL-200 (JL1030)	ASTM Class 25
15	Pump body fastening bolts & screws	Galvanized steel		

* 2/4 pole: 25/32/40-125, 25/32/40-160, 25/32/40-200

** 2 pole: 65-160/40, 65-160/55, 65-160/75; 4 pole: 65-160/05, 65-160/07, 65-160/11A

*** 2 pole: 65-160/92, 65-160/110A, 65-160/110; 4 pole: 65-160/11, 65-160/15

sh_shs-en_d_tm

SHS SERIES ELECTRIC PUMP CROSS SECTION AND MAIN COMPONENTS

04952_B_DS

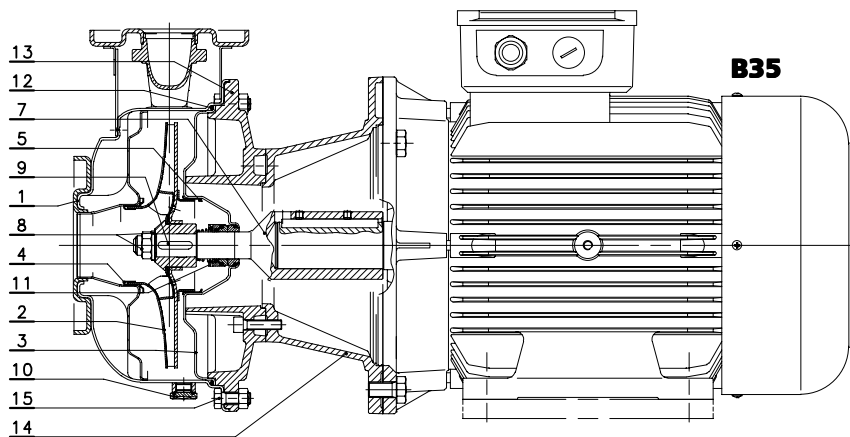

VERSIONS	
2 POLES	4 POLES
SHS 25-250/110	SHS4 80-250/110
SHS 32-250/110	
SHS 40-250/110A	
SHS 40-250/110	
SHS 40-250/150	
SHS 50-200/110A	
SHS 50-200/110	
SHS 50-250/150	
SHS 50-250/185	
SHS 50-250/220	
SHS 65-160/110A	
SHS 65-160/110	
SHS 65-200/150	
SHS 65-200/185	
SHS 65-200/220	
SHS 65-250/300	
SHS 65-250/370	
SHS 80-160/110	
SHS 80-160/150	
SHS 80-160/185	
SHS 80-200/220	
SHS 80-200/300	
SHS 80-200/370	

sh-shs-s-en_b_mo

REF. N.	NAME	MATERIAL	REFERENCE STANDARDS	
			EUROPE	USA
1	Pump body	Stainless steel	EN 10088-1-X2CrNiMo17-12-2 (1.4404)	AISI 316L
2	Impeller 25-32-40-50-65(160)**	Stainless steel	EN 10088-1-X2CrNiMo17-12-2 (1.4404)	AISI 316L
	Impeller 65(160)***, 65(200-250)-80	Stainless steel	EN 10213-4-GX5CrNiMo19-11-2 (1.4408)	ASTM CF8M (cast AISI 316)
3	Seal housing	Stainless steel	EN 10088-1-X2CrNiMo17-12-2 (1.4404)	AISI 316L
4	Wear ring	Stainless steel	EN 10088-1-X2CrNiMo17-12-2 (1.4404)	AISI 316L
5	Counterwear ring	Stainless steel	EN 10088-1-X2CrNiMo17-12-2 (1.4404)	AISI 316L
7	Rigid shaft coupling	Stainless steel	EN 10088-1-X5CrNiMo17-12-2 (1.4401)	AISI 316
8	Impeller locknut and washer	Stainless steel	EN 10088-1-X5CrNiMo17-12-2 (1.4401)	AISI 316
9	Tab	Acciaio inox	EN 10088-1-X2CrNiMo17-12-2 (1.4404)	AISI 316L
10	Fill/drain plugs	Stainless steel	EN 10088-1-X5CrNiMo17-12-2 (1.4401)	AISI 316
11	Mechanical seal	Ceramic / Carbon / FPM (standard version)		
12	Elastomers	FPM (standard version)		
13	Adapter *	Aluminium	EN 1706-AC-AISI11Cu2 (Fe) (AC46100)	-
	Adapter	Cast iron	EN 1561-GJL-200 (JL1030)	ASTM Class 25
14	Adapter motor coupling	Cast iron	EN 1561-GJL-200 (JL1030)	ASTM Class 25
15	Pump body fastening bolts & screws	Galvanized steel		

* 2/4 pole: 25/32/40-125, 25/32/40-160, 25/32/40-200

** 2 pole: 65-160/40, 65-160/55, 65-160/75; 4 pole: 65-160/05, 65-160/07, 65-160/11A

*** 2 pole: 65-160/92, 65-160/110A, 65-160/110; 4 pole: 65-160/11, 65-160/15

sh_shs-en_d_tm

SHF BARE SHAFT SERIES ELECTRIC PUMP CROSS SECTION AND MAIN COMPONENTS

04979_C_DS

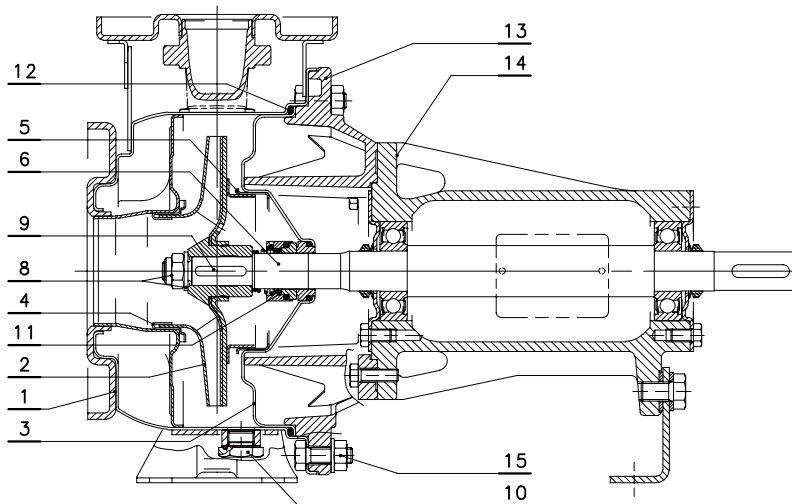
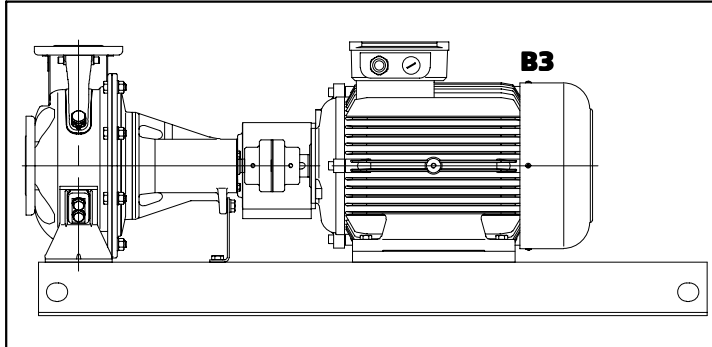

VERSIONS

SHF 25-125
SHF 25-160
SHF 25-200
SHF 25-250
SHF 32-125
SHF 32-160
SHF 32-200
SHF 32-250
SHF 40-125
SHF 40-160
SHF 40-200
SHF 40-250
SHF 50-125
SHF 50-160
SHF 50-200
SHF 50-250
SHF 65-160
SHF 65-200
SHF 65-250
SHF80-160
SHF 80-200
SHF 80-250

sh-shf-p-en_a_mo

REF. N.	NAME	MATERIAL	REFERENCE STANDARDS	
			EUROPE	USA
1	Pump body	Stainless steel	EN 10088-1-X2CrNiMo17-12-2 (1.4404)	AISI 316L
2	Impeller 25-32-40-50-65(160)**	Stainless steel	EN 10088-1-X2CrNiMo17-12-2 (1.4404)	AISI 316L
	Impeller 65(160)***, 65(200-250)-80	Stainless steel	EN 10213-4-GX5CrNiMo19-11-2 (1.4408)	ASTM CF8M (cast AISI 316)
3	Seal housing	Stainless steel	EN 10088-1-X2CrNiMo17-12-2 (1.4404)	AISI 316L
4	Wear ring	Stainless steel	EN 10088-1-X2CrNiMo17-12-2 (1.4404)	AISI 316L
5	Counterwear ring	Stainless steel	EN 10088-1-X2CrNiMo17-12-2 (1.4404)	AISI 316L
6	Shaft extension	Stainless steel	EN 10088-1-X5CrNiMo17-12-2 (1.4401)	AISI 316
8	Impeller locknut and washer	Stainless steel	EN 10088-1-X5CrNiMo17-12-2 (1.4401)	AISI 316
9	Tab	Stainless steel	EN 10088-1-X2CrNiMo17-12-2 (1.4404)	AISI 316L
10	Fill/drain plugs	Stainless steel	EN 10088-1-X5CrNiMo17-12-2 (1.4401)	AISI 316
11	Mechanical seal	Ceramic / Carbon / FPM (standard version)		
12	Elastomers	FPM (standard version)		
13	Adapter *	Aluminium	EN 1706-AC-AISI11Cu2 (Fe) (AC46100)	-
	Adapter	Cast iron	EN 1561-GJL-200 (JL1030)	ASTM Class 25
14	Transmission support body	Cast iron	EN 1561-GJL-200 (JL1030)	ASTM Class 25
15	Pump body fastening bolts & screws	Galvanized steel		

* 2/4 pole: 25/32/40-125, 25/32/40-160, 25/32/40-200

** 2 pole: 65-160/40, 65-160/55, 65-160/75; 4 pole: 65-160/05, 65-160/07, 65-160/11A

*** 2 pole: 65-160/92, 65-160/110A, 65-160/110; 4 pole: 65-160/11, 65-160/15

sh_shf-en_d_tm

SH SERIES

MECHANICAL SEAL SERIES, ACCORDING TO EN 12756

Mechanical seal with mounting dimensions according to EN12756 (ex DIN 24960) and ISO 3069.

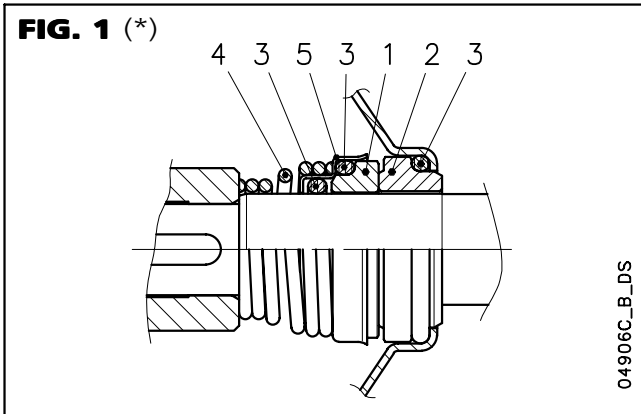

(*) Standard version

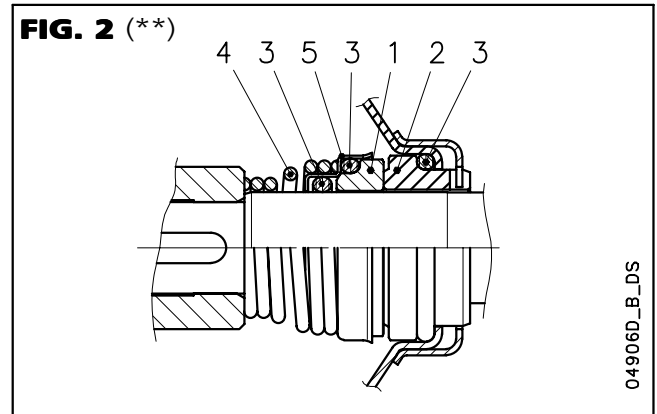

(***) Version with fixed assembly anti-rotation

LIST OF MATERIALS

POSITION 1 - 2	POSITION 3	POSITION 4 - 5
B : Resin impregnated carbon	E : EPDM	G : AISI 316
Q ₁ : Silicon carbide	V : FPM	
V : Ceramic		

sh_ten-mec-en_a_tm

SEAL TYPES

TYPE	POSITION					TEMPERATURE (°C)
	1 ROTATING ASSEMBLY	2 FIXED ASSEMBLY	3 ELASTOMERS	4 SPRINGS	5 OTHER COMPONENTS	
STANDARD MECHANICAL SEAL						
VBVGG	V	B	V	G	G	-10 +120
OTHER MECHANICAL SEAL TYPES						
Q ₁ BVGG	Q ₁	B	V	G	G	-10 +120
Q ₁ Q ₁ VGG	Q ₁	Q ₁	V	G	G	-10 +120
VBEGG	V	B	E	G	G	-30 +120
Q ₁ BEGG	Q ₁	B	E	G	G	-30 +120
Q ₁ Q ₁ EGG	Q ₁	Q ₁	E	G	G	-30 +120

sh_tipi-ten-mec-en_a_tc

PRESSURE / TEMPERATURE APPLICATIONS LIMITS FOR COMPLETE PUMP (APPLICABLE WITH ANY OF THE SEALS LISTED ABOVE)

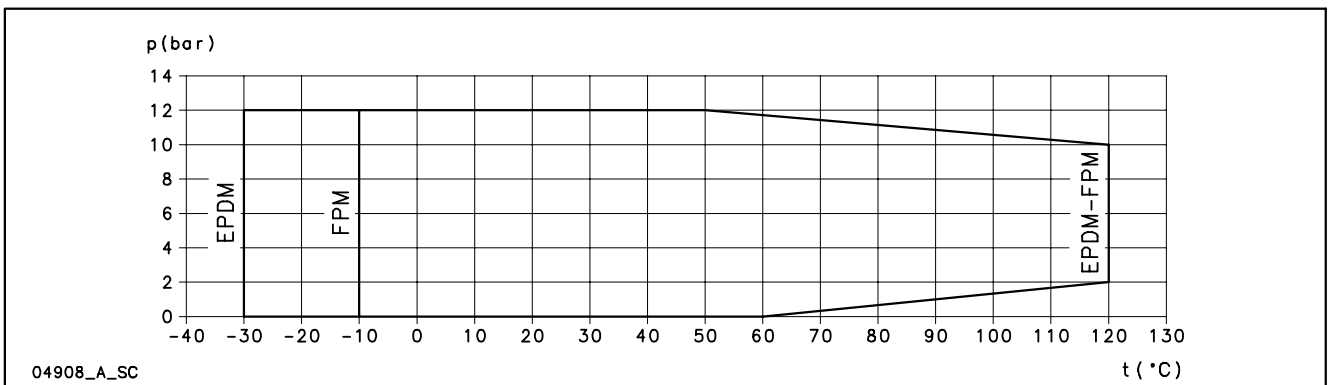

04908_A_SC

ErP 2009/125/EC

SH SERIES MOTORS

With the “Energy using Products” (EuP 2005/32/EC) and “Energy related Products” (ErP 2009/125/EC) directives, the European Commission has established requirements for promoting the use of products with low power consumption.

The various products considered include three-phase, 50 Hz surface motors, with power outputs ranging from 0,75 to 375 kW, also when integrated with other products, with characteristics as defined by the specific **Regulation (EC) n. 640/2009** implementing the requirements of the EuP and ErP Directives which also establish the following deadlines:

from	kW	minimum level of efficiency (IE)
16th June 2011	0,75 ÷ 375	IE2
1st January 2015	< 7,5	IE2
	7,5 ÷ 375	IE3 IE2 fitted with variable speed drive
1st January 2017	0,75 ÷ 375	IE3
		IE2 fitted with variable speed drive

- **Standard three-phase surface motors**
≥ **0,75 kW supplied as IE2 or IE3.**
- Short-circuit squirrel-cage motor, enclosed construction with external ventilation (TEFC).
- IP55 protection degree.
- Insulation class 155 (F).
- Electrical performances according to EN 60034-1.
- IE efficiency according to EN 60034-30 (≥ 0,75 kW).
- Cable gland with metric according to EN 50262.
- **PTC included** in motors:
2-pole from 30 to 37 kW (B35),
from 22 to 75 kW (B3).

- **Single-phase** version:
220-240 V 50 Hz
Built-in automatic reset overload protection up to 1,5 kW.
For higher powers the protection must be provided by the user.
- **Three-phase** version:
220-240/380-415 V 50 Hz for power up to 3 kW.
380-415/660-690 V 50 Hz for power above 3 kW.
Overload protection to be provided by the user.

SHE SERIES SINGLE-PHASE MOTORS AT 50 Hz, 2 POLES

P _N kW	MOTOR TYPE	IEC SIZE*	Construction Design	INPUT CURRENT I _n (A) 220-240 V	CAPACITOR		DATA FOR 230 V 50 Hz VOLTAGE						
					μF	V	min ⁻¹	I _s / I _n	η %	cosφ	T _n Nm	T _s /T _n	T _m /T _n
0,75	SM90RB14/107	90R	B14	4,83-5,23	30	450	2875	5,28	71,8	0,92	2,49	0,70	2,59
1,1	SM90RB14/111	90R	B14	6,88-6,65	30	450	2800	3,89	74,7	0,96	3,75	0,46	1,72
1,5	SM90RB14/115	90R	B14	9,21-8,58	40	450	2810	4,00	76,1	0,98	5,15	0,39	1,74
2,2	PLM90B14/122	90	B14	12,5-11,6	70	450	2825	4,47	82,4	0,97	7,43	0,53	1,87

* R = Reduced size of motor casing as compared to shaft extension and flange.

SHE SERIES THREE-PHASE MOTORS AT 50 Hz, 2 POLES

P _N kW	Efficiency η_N %																		IE	Year of manufacture
	Δ 220 V Y 380 V			Δ 230 V Y 400 V			Δ 240 V Y 415 V			Δ 380 V Y 660 V			Δ 400 V Y 690 V			Δ 415 V				
	4/4	3/4	2/4	4/4	3/4	2/4	4/4	3/4	2/4	4/4	3/4	2/4	4/4	3/4	2/4	4/4	3/4	2/4		
0,75	82,5	83,1	81,3	82,8	82,7	80,1	82,6	82,0	78,9	82,5	82,0	78,9	82,5	82,0	78,9	82,5	82,0	78,9	3	from 03/2012
1,1	84,0	84,7	83,4	84,4	84,5	82,5	84,3	84,0	81,4	84,0	84,0	81,4	84,0	84,0	81,4	84,0	84,0	81,4		
1,5	85,6	86,5	85,8	85,9	86,4	84,9	86,0	86,0	84,0	85,6	86,0	84,0	85,6	86,0	84,0	85,6	86,0	84,0		
2,2	83,7	83,7	83,7	83,7	83,7	83,7	83,7	83,7	83,7	83,7	83,7	83,7	83,7	83,7	83,7	83,7	83,7	83,7	2	from 06/2011
3	85,5	86,8	85,6	86,1	86,8	85,6	86,3	86,8	85,6	86,3	86,8	85,6	86,3	86,8	85,6	86,3	86,8	85,6		
4	86,3	86,3	86,3	86,3	86,3	86,3	86,3	86,3	86,3	86,3	86,3	86,3	86,3	86,3	86,3	86,3	86,3	86,3		
5,5	87,6	87,6	87,6	87,6	87,6	87,6	87,6	87,6	87,6	87,6	87,6	87,6	87,6	87,6	87,6	87,6	87,6	87,6		
7,5	88,6	88,1	88,1	88,6	88,1	88,1	88,6	88,1	88,1	88,6	88,1	88,1	88,6	88,1	88,1	88,6	88,1	88,1		
9,2	89,3	88,8	88,8	89,3	88,8	88,8	89,3	88,8	88,8	89,3	88,8	88,8	89,3	88,8	88,8	89,3	88,8	88,8		
11	90,3	91,1	90,3	90,3	91,1	90,3	90,3	91,1	90,3	90,3	91,1	90,3	90,8	91,1	90,3	91,0	91,1	90,3		
15	90,3	90,3	90,3	90,3	90,3	90,3	90,3	90,3	90,3	90,3	90,3	90,3	90,3	90,3	90,3	90,3	90,3	90,3		
18,5	91,2	91,2	91,2	91,2	91,2	91,2	91,2	91,2	91,2	91,2	91,2	91,2	91,2	91,2	91,2	91,2	91,2	91,2		
22	91,3	91,3	91,3	91,3	91,3	91,3	91,3	91,3	91,3	91,3	91,3	91,3	91,3	91,3	91,3	91,3	91,3	91,3		

P _N kW	Manufacturer		IEC SIZE*	Construction Design	N. of Poles	f _n Hz	Data for 400 V / 50 Hz Voltage				
	Lowara srl Unipersonale Reg. No. 03471820260 Montecchio Maggiore Vicenza - Italia						cos ϕ	I _s / I _N	T _N Nm	T _s /T _N	T _m /T _N
	Model										
0,75	SM90RB14S/307PE		90R	SPECIAL	2	50	0,78	7,38	2,48	3,57	3,75
1,1	SM90RB14S/311PE		90R				0,79	8,31	3,63	3,95	3,95
1,5	SM90RB14S/315PE		90R				0,80	8,80	4,96	4,31	4,10
2,2	PLM90B14S/322		90				0,80	8,63	7,25	3,74	3,71
3	PLM90B14S/330		90				0,82	8,39	9,96	3,50	3,32
4	PLM112RB14S/340		112R				0,85	9,52	13,1	3,04	4,40
5,5	PLM112B14S/355		112				0,87	10,3	18,1	4,43	5,80
7,5	PLM132B14S/375		132				0,87	9,21	24,5	3,26	4,55
9,2	PLM132B14S/392		132				0,88	9,66	30,3	3,17	4,54
11	PLM132B14S/3110		132				0,87	9,72	36,0	3,46	4,56
15	PLM160B34S/3150		160				0,91	8,45	48,6	2,26	3,81
18,5	PLM160B34S/3185		160				0,88	9,75	59,8	2,82	4,53
22	PLM160B34S/3220		160	0,89	9,50	71,1	2,74	4,26			

P _N kW	Voltage U _N V										n _N min ⁻¹	Observe the regulations and codes locally in force regarding sorted waste disposal.	Operating conditions **				
	Δ			Y			Δ			Y			Altitude Above Sea Level (m)	T. amb min/max °C	ATEX		
	220 V	230 V	240 V	380 V	400 V	415 V	380 V	400 V	415 V	660 V						690 V	I _N (A)
0,75	2,96	2,94	2,96	1,71	1,70	1,71	1,70	1,69	1,70	0,98	0,98	2875 ÷ 2895	≤ 1000	-15 / 40	No		
1,1	4,19	4,14	4,16	2,42	2,39	2,40	2,41	2,38	2,38	1,39	1,37	2870 ÷ 2900					
1,5	5,56	5,49	5,51	3,21	3,17	3,18	3,21	3,18	3,19	1,85	1,84	2870 ÷ 2895					
2,2	8,05	8,04	8,09	4,65	4,64	4,67	4,62	4,61	4,63	2,67	2,66	2885 ÷ 2900					
3	10,8	10,6	10,6	6,23	6,14	6,12	6,18	6,10	6,06	3,57	3,52	2850 ÷ 2885					
4	13,6	13,5	13,5	7,88	7,77	7,79	7,80	7,63	7,65	4,51	4,41	2895 ÷ 2920					
5,5	18,3	18,0	17,9	10,6	10,4	10,3	10,6	10,4	10,5	6,14	6,02	2885 ÷ 2905					
7,5	25,4	24,8	24,4	14,7	14,3	14,1	14,5	14,0	13,9	8,35	8,11	2920 ÷ 2935					
9,2	29,7	28,9	28,3	17,2	16,7	16,4	17,3	16,8	16,6	10,0	9,70	2910 ÷ 2930					
11	36,0	35,1	34,7	20,8	20,3	20,0	20,8	20,3	20,1	12,0	11,7	2910 ÷ 2925					
15	47,2	45,3	44,0	27,2	26,2	25,4	27,2	26,0	25,3	15,7	15,0	2940 ÷ 2950					
18,5	58,3	56,9	55,9	33,7	32,9	32,3	34,1	33,2	32,8	19,7	19,1	2945 ÷ 2955					
22	68,3	66,2	64,3	39,4	38,2	37,1	40,0	38,6	37,8	23,1	22,3	2945 ÷ 2955					

* R = Reduced size of motor casing as compared to shaft extension and flange.

** Operating conditions to be referred to motor only. About electric pump, refer to limits in user's manual.

SHS SERIES (up to 22 kW) THREE-PHASE MOTORS AT 50 Hz, 2 POLES

P _N kW	Efficiency η_N %																		IE	Year of manufacture
	Δ 220 V Y 380 V			Δ 230 V Y 400 V			Δ 240 V Y 415 V			Δ 380 V Y 660 V			Δ 400 V Y 690 V			Δ 415 V				
	4/4	3/4	2/4	4/4	3/4	2/4	4/4	3/4	2/4	4/4	3/4	2/4	4/4	3/4	2/4	4/4	3/4	2/4		
0,75	82,5	83,1	81,3	82,8	82,7	80,1	82,6	82,0	78,9	82,5	82,0	78,9	82,5	82,0	78,9	82,5	82,0	78,9	3	from 03/2012
1,1	84,0	84,7	83,4	84,4	84,5	82,5	84,3	84,0	81,4	84,0	84,0	81,4	84,0	84,0	81,4	84,0	84,0	81,4		
1,5	85,6	86,5	85,8	85,9	86,4	84,9	86,0	86,0	84,0	85,6	86,0	84,0	85,6	86,0	84,0	85,6	86,0	84,0		
2,2	83,7	83,7	83,7	83,7	83,7	83,7	83,7	83,7	83,7	83,7	83,7	83,7	83,7	83,7	83,7	83,7	83,7	83,7	2	from 06/2011
3	85,5	86,8	85,6	86,1	86,8	85,6	86,3	86,8	85,6	85,5	86,8	85,6	85,5	86,8	85,6	85,5	86,8	85,6		
4	86,3	86,3	86,3	86,3	86,3	86,3	86,3	86,3	86,3	86,3	86,3	86,3	86,3	86,3	86,3	86,3	86,3	86,3		
5,5	87,6	87,6	87,6	87,6	87,6	87,6	87,6	87,6	87,6	87,6	87,6	87,6	87,6	87,6	87,6	87,6	87,6	87,6		
7,5	88,6	88,1	88,1	88,6	88,1	88,1	88,6	88,1	88,1	88,6	88,1	88,1	88,6	88,1	88,1	88,6	88,1	88,1		
11	89,8	89,8	89,8	89,8	89,8	89,8	89,8	89,8	89,8	89,8	89,8	89,8	89,8	89,8	89,8	89,8	89,8	89,8		
15	90,3	90,3	90,3	90,3	90,3	90,3	90,3	90,3	90,3	90,3	90,3	90,3	90,3	90,3	90,3	90,3	90,3	90,3		
18,5	91,2	91,2	91,2	91,2	91,2	91,2	91,2	91,2	91,2	91,2	91,2	91,2	91,2	91,2	91,2	91,2	91,2	91,2		
22	91,3	91,3	91,3	91,3	91,3	91,3	91,3	91,3	91,3	91,3	91,3	91,3	91,3	91,3	91,3	91,3	91,3	91,3		

P _N kW	Manufacturer		IEC SIZE*	Construction Design	N. of Poles	f _N Hz	Data for 400 V / 50 Hz Voltage				
	Lowara srl Unipersonale Reg. No. 03471820260 Montecchio Maggiore Vicenza - Italia						cosφ	I _s / I _N	T _N Nm	Ts/T _N	Tm/T _N
	Model										
0,75	SM80B5/307PE		80	B5	2	50	0,78	7,38	2,48	3,57	3,75
1,1	SM80B5/311PE		80				0,79	8,31	3,63	3,95	3,95
1,5	SM90RB5/315PE		90R				0,80	8,80	4,96	4,31	4,10
2,2	PLM90B5/322		90				0,80	8,63	7,25	3,74	3,71
3	PLM100RB5/330		100R				0,82	8,39	9,96	3,50	3,32
4	PLM112RB5/340		112R				0,85	9,52	13,1	3,04	4,40
5,5	PLM132RB5/355		132R				0,87	10,3	18,1	4,43	5,80
7,5	PLM132B5/375		132	0,87	9,21	24,5	3,26	4,55			
11	PLM160B35/3110		160	B35	2	50	0,88	8,14	35,6	2,22	4,00
15	PLM160B35/3150		160				0,91	8,45	48,6	2,26	3,81
18,5	PLM160B35/3185		160				0,88	9,75	59,8	2,82	4,53
22	PLM180RB35/3220		180R				0,89	9,50	71,1	2,74	4,26
							0,89	9,50	71,1	2,74	4,26

P _N kW	Voltage U _N V											n _N min ⁻¹	Observe the regulations and codes locally in force regarding sorted waste disposal.	Operating conditions **		
	Δ			Y			Δ			Y				Altitude Above Sea Level (m)	T. amb min/max °C	ATEX
	220 V	230 V	240 V	380 V	400 V	415 V	380 V	400 V	415 V	660 V	690 V					
0,75	2,96	2,94	2,96	1,71	1,70	1,71	1,70	1,69	1,70	0,98	0,98	2875 ÷ 2895	≤ 1000	-15 / 40	No	
1,1	4,19	4,14	4,16	2,42	2,39	2,40	2,41	2,38	2,38	1,39	1,37	2870 ÷ 2900				
1,5	5,56	5,49	5,51	3,21	3,17	3,18	3,21	3,18	3,19	1,85	1,84	2870 ÷ 2895				
2,2	8,05	8,04	8,09	4,65	4,64	4,67	4,62	4,61	4,63	2,67	2,66	2885 ÷ 2900				
3	10,8	10,6	10,6	6,23	6,14	6,12	6,18	6,10	6,06	3,57	3,52	2850 ÷ 2885				
4	13,6	13,5	13,5	7,88	7,77	7,79	7,80	7,63	7,65	4,51	4,41	2895 ÷ 2920				
5,5	18,3	18,0	17,9	10,6	10,4	10,3	10,6	10,4	10,5	6,14	6,02	2885 ÷ 2905				
7,5	25,4	24,8	24,4	14,7	14,3	14,1	14,5	14,0	13,9	8,35	8,11	2920 ÷ 2935				
11	35,5	34,3	33,4	20,5	19,8	19,3	20,6	19,9	19,5	11,9	11,5	2940 ÷ 2950				
15	47,2	45,3	44,0	27,2	26,2	25,4	27,2	26,0	25,3	15,7	15,0	2940 ÷ 2950				
18,5	58,3	56,9	55,9	33,7	32,9	32,3	34,1	33,2	32,8	19,7	19,1	2945 ÷ 2955				
22	68,3	66,2	64,3	39,4	38,2	37,1	40,0	38,6	37,8	23,1	22,3	2945 ÷ 2955				

* R = Reduced size of motor casing as compared to shaft extension and flange.

shs-ie2-mott-zp50-en_b_te

** Operating conditions to be referred to motor only. About electric pump, refer to limits in user's manual.

SHF SERIES (up to 18,5 kW) THREE-PHASE MOTORS AT 50 Hz, 2 POLES

P _N kW	Efficiency η_N %																		IE	Year of manufacture
	Δ 220 V Y 380 V			Δ 230 V Y 400 V			Δ 240 V Y 415 V			Δ 380 V Y 660 V			Δ 400 V Y 690 V			Δ 415 V				
	4/4	3/4	2/4	4/4	3/4	2/4	4/4	3/4	2/4	4/4	3/4	2/4	4/4	3/4	2/4	4/4	3/4	2/4		
0,75	82,5	83,1	81,3	82,8	82,7	80,1	82,6	82,0	78,9	82,5	82,0	78,9	82,5	82,0	78,9	82,5	82,0	78,9	3	from 03/2012
1,1	84,0	84,7	83,4	84,4	84,5	82,5	84,3	84,0	81,4	84,0	84,0	81,4	84,0	84,0	81,4	84,0	84,0	81,4		
1,5	81,8	81,8	81,8	81,8	81,8	81,8	81,8	81,8	81,8	81,8	81,8	81,8	81,8	81,8	81,8	81,8	81,8	81,8	2	from 06/2011
2,2	83,7	83,7	83,7	83,7	83,7	83,7	83,7	83,7	83,7	83,7	83,7	83,7	83,7	83,7	83,7	83,7	83,7	83,7		
3	85,1	85,1	85,1	85,1	85,1	85,1	85,1	85,1	85,1	85,1	85,1	85,1	85,1	85,1	85,1	85,1	85,1	85,1		
4	86,3	86,3	86,3	86,3	86,3	86,3	86,3	86,3	86,3	86,3	86,3	86,3	86,3	86,3	86,3	86,3	86,3	86,3		
5,5	87,6	87,6	87,0	87,6	87,6	87,0	87,6	87,6	87,0	87,6	87,6	87,0	87,6	87,6	87,0	87,6	87,6	87,0		
7,5	88,6	88,1	88,1	88,6	88,1	88,1	88,6	88,1	88,1	88,6	88,1	88,1	88,6	88,1	88,1	88,6	88,1	88,1		
11	89,8	89,8	89,8	89,8	89,8	89,8	89,8	89,8	89,8	89,8	89,8	89,8	89,8	89,8	89,8	89,8	89,8	89,8		
15	90,3	90,3	90,3	90,3	90,3	90,3	90,3	90,3	90,3	90,3	90,3	90,3	90,3	90,3	90,3	90,3	90,3	90,3		
18,5	91,2	91,2	91,2	91,2	91,2	91,2	91,2	91,2	91,2	91,2	91,2	91,2	91,2	91,2	91,2	91,2	91,2	91,2		

P _N kW	Manufacturer		IEC SIZE	Construction Design	N. of Poles	f _N Hz	Data for 400 V / 50 Hz Voltage				
	Lowara srl Unipersonale Reg. No. 03471820260 Montecchio Maggiore Vicenza - Italia						cos ϕ	I _s / I _N	T _N Nm	T _s /T _N	T _m /T _N
	Model										
0,75	SM80B3/307PE		80	B3	2	50	0,78	7,38	2,48	3,57	3,75
1,1	SM80B3/311PE		80				0,79	8,31	3,63	3,95	3,95
1,5	PLM90B3/315		90				0,86	7,86	4,96	3,34	3,27
2,2	PLM90B3/322		90				0,80	8,63	7,25	3,74	3,71
3	PLM100B3/330		100				0,84	9,45	9,83	3,59	4,27
4	PLM112B3/340		112				0,87	9,16	13,2	3,60	4,59
5,5	PLM132B3/355		132				0,83	9,93	17,9	3,34	4,66
7,5	PLM132B3/375		132				0,87	9,21	24,5	3,26	4,55
11	PLM160B3/3110		160				0,88	8,14	35,6	2,22	4,00
15	PLM160B3/3150		160				0,91	8,45	48,6	2,26	3,81
18,5	PLM160B3/3185		160	0,88	9,75	59,8	2,82	4,53			

P _N kW	Voltage U _N V										η_N min ⁻¹	Observe the regulations and codes locally in force regarding sorted waste disposal.	Operating conditions **				
	Δ			Y			Δ			Y			Altitude Above Sea Level (m)	T. amb min/max °C	ATEX		
	220 V	230 V	240 V	380 V	400 V	415 V	380 V	400 V	415 V	660 V						690 V	I _N (A)
0,75	2,96	2,94	2,96	1,71	1,70	1,71	1,70	1,69	1,70	0,98	0,98	2875 ÷ 2895	≤ 1000	-15 / 40	No		
1,1	4,19	4,14	4,16	2,42	2,39	2,40	2,41	2,38	2,38	1,39	1,37	2870 ÷ 2900					
1,5	5,53	5,23	5,13	3,19	3,02	2,96	3,19	3,03	2,96	1,84	1,75	2865 ÷ 2895					
2,2	8,05	8,04	8,09	4,65	4,64	4,67	4,62	4,61	4,63	2,67	2,66	2885 ÷ 2900					
3	10,4	10,2	10,3	5,98	5,91	5,92	6,01	5,95	5,96	3,47	3,44	2905 ÷ 2920					
4	13,3	13,0	12,9	7,67	7,50	7,43	7,68	7,51	7,45	4,44	4,34	2890 ÷ 2905					
5,5	19,2	19,1	19,2	11,1	11,0	11,1	10,9	10,8	10,8	6,30	6,22	2930 ÷ 2945					
7,5	25,4	24,8	24,4	14,7	14,3	14,1	14,5	14,0	13,9	8,35	8,11	2920 ÷ 2935					
11	35,5	34,3	33,4	20,5	19,8	19,3	20,6	19,9	19,5	11,9	11,5	2940 ÷ 2950					
15	47,2	45,3	44,0	27,2	26,2	25,4	27,2	26,0	25,3	15,7	15,0	2940 ÷ 2950					
18,5	58,3	56,9	55,9	33,7	32,9	32,3	34,1	33,2	32,8	19,7	19,1	2945 ÷ 2955					

** Operating conditions to be referred to motor only. About electric pump, refer to limits in user's manual.

shf-ie2-mott18-2p50-en_b_te

SHS SERIES (from 30 to 37 kW)
SHF SERIES (from 22 to 75 kW)
THREE-PHASE MOTORS AT 50 Hz, 2 POLES

P _N kW	Efficiency η_N %									IE	Year of manufacture
	Δ 380 V Y 660 V			Δ 400 V Y 690 V			Δ 415 V				
	4/4	3/4	2/4	4/4	3/4	2/4	4/4	3/4	2/4		
22	91,8	92,2	92,2	92,0	92,4	92,2	92,4	92,4	91,8	2	from 06/2011
30	92,6	92,9	92,7	92,5	93,0	92,9	93,0	93,0	92,3		
37	93,0	93,3	93,2	93,0	93,4	93,3	93,5	93,4	92,8		
45	93,2	93,5	93,4	93,3	93,6	93,6	93,8	93,6	93,1		
55	93,6	93,8	93,8	93,6	93,9	93,9	94,0	93,8	93,3		
75	94,1	94,3	93,6	93,4	94,3	94,3	94,3	94,2	93,2		

P _N kW	Manufacturer		IEC SIZE	Construction Design	N. of Poles	f _N Hz	Data for 400 V / 50 Hz Voltage				
	WEG Equipamentos Eletricos S.A. Reg. No. 07.175.725/0010-50 Jaragua do Sul - SC (Brazil)						cos ϕ	I _s / I _N	T _N Nm	T _s /T _N	T _m /T _N
	Model										
22	W22 180M2-B3 22kW		180	B3	2	50	0,88	7,30	71,40	2,20	3,00
30	W22 200L2-B3 30kW		200	B3			0,87	6,50	97,00	2,40	2,70
	W22 200L2-B35 30kW			B35							
37	W22 200L2-B3 37kW		200	B3			0,87	6,80	120,0	2,40	2,60
	W22 200L2-B35 37kW			B35							
45	W22 225S/M2-B3 45kW		225	B3			0,89	7,00	145,0	2,20	2,80
55	W22 250S/M2-B3 55kW		250		0,89	7,00	178,0	2,20	2,80		
75	W22 280S/M2-B3 75kW		280		0,89	7,00	241,0	2,00	2,80		

P _N kW	Voltage U _N V					n _N min ⁻¹	See note.	Operating conditions **		
	Δ			Y				Altitude Above Sea Level (m)	T. amb min/max °C	ATEX
	380 V	400 V	415 V	660 V	690 V					
	I _N (A)									
22	40,90	39,10	38,10	23,55	22,67	2940 ÷ 2950	≤ 1000	-15 / 40	No	
30	55,90	53,60	52,20	32,18	31,07	2950 ÷ 2960				
37	68,70	65,80	64,00	39,55	38,14	2945 ÷ 2955				
45	81,50	78,00	75,80	46,92	45,22	2955 ÷ 2960				
55	99,20	95,00	92,50	57,12	55,07	2955 ÷ 2960				
75	135,00	129,00	126,00	77-73	74,78	2970 ÷ 2975				

** Operating conditions to be referred to motor only. About electric pump, refer to limits in user's manual.

shf-ie2-mott75-2p50-en_b_te

Note: Observe the regulations and codes locally in force regarding sorted waste disposal.

SHE4 SERIES THREE-PHASE MOTORS AT 50 Hz, 4 POLES

P _N kW	Efficiency η_N %																		IE	Year of manufacture				
	Δ 220 V Y 380 V			Δ 230 V Y 400 V			Δ 240 V Y 415 V			Δ 380 V Y 660 V			Δ 400 V Y 690 V			Δ 415 V								
	4/4	3/4	2/4	4/4	3/4	2/4	4/4	3/4	2/4	4/4	3/4	2/4	4/4	3/4	2/4	4/4	3/4	2/4						
0,25	-	-	-	-	-	-	-	-	-	-	-	-	-	-	-	-	-	-	-	-	-	-	-	-
0,37	-	-	-	-	-	-	-	-	-	-	-	-	-	-	-	-	-	-	-	-	-	-	-	-
0,55	-	-	-	-	-	-	-	-	-	-	-	-	-	-	-	-	-	-	-	-	-	-	-	-
0,75	80,4	81,3	79,8	81,1	81,4	79,1	81,4	81,2	78,4	80,4	81,2	78,4	80,4	81,2	78,4	80,4	81,2	78,4	80,4	81,2	78,4	80,4	81,2	78,4
1,1	81,4	81,4	81,1	81,4	81,4	81,1	81,4	81,4	81,1	81,4	81,4	81,1	81,4	81,4	81,1	81,4	81,4	81,1	81,4	81,4	81,1	81,4	81,4	81,1
1,5	83,1	83,1	82,0	83,1	83,1	82,0	83,1	83,1	82,0	83,1	83,1	82,0	83,1	83,1	82,0	83,1	83,1	82,0	83,1	83,1	82,0	83,1	83,1	82,0
2,2	84,7	84,7	84,7	84,7	84,7	84,7	84,7	84,7	84,7	84,7	84,7	84,7	84,7	84,7	84,7	84,7	84,7	84,7	84,7	84,7	84,7	84,7	84,7	84,7
3	85,5	85,5	84,1	85,5	85,5	84,1	85,5	85,5	84,1	85,5	85,5	84,1	85,5	85,5	84,1	85,5	85,5	84,1	85,5	85,5	84,1	85,5	85,5	84,1
4	86,6	86,6	86,6	86,6	86,6	86,6	86,6	86,6	86,6	86,6	86,6	86,6	86,6	86,6	86,6	86,6	86,6	86,6	86,6	86,6	86,6	86,6	86,6	86,6
5,5	88,0	88,0	88,0	88,0	88,0	88,0	88,0	88,0	88,0	88,0	88,0	88,0	88,0	88,0	88,0	88,0	88,0	88,0	88,0	88,0	88,0	88,0	88,0	88,0
7,5	88,7	88,7	88,7	88,7	88,7	88,7	88,7	88,7	88,7	88,7	88,7	88,7	88,7	88,7	88,7	88,7	88,7	88,7	88,7	88,7	88,7	88,7	88,7	88,7
11	89,8	89,8	89,8	89,8	89,8	89,8	89,8	89,8	89,8	89,8	89,8	89,8	89,8	89,8	89,8	89,8	89,8	89,8	89,8	89,8	89,8	89,8	89,8	89,8

P _N kW	Manufacturer		IEC SIZE*	Construction Design	N. of Poles	f _N Hz	Data for 400 V / 50 Hz Voltage				
	Lowara srl Unipersonale Reg. No. 03471820260 Montecchio Maggiore Vicenza - Italia						cos ϕ	I _s / I _N	T _N Nm	T _s /T _N	T _m /T _N
	Model										
0,25	SM471B5/302		71	SPECIAL	4	50	0,59	3,58	1,71	3,16	2,63
0,37	SM471B5/304		71				0,60	3,39	2,57	3,40	2,47
0,55	SM490RB14S/305		90R				0,67	3,95	3,77	2,45	2,38
0,75	LLM490RB5S/307		90R				0,75	5,78	5,03	2,77	3,31
1,1	PLM490B5S/311		90				0,72	6,34	7,27	2,80	3,43
1,5	PLM490B5S/315		90				0,67	6,79	9,88	3,33	3,67
2,2	PLM4100B5S/322		100				0,77	7,50	14,4	2,71	3,97
3	PLM4100B5S/330		100				0,73	7,84	19,6	2,96	4,09
4	PLM4112B5S/340		112				0,78	7,91	26,3	2,86	3,94
5,5	PLM4132B14S/355		132				0,78	7,89	35,9	2,79	3,47
7,5	PLM4132B14S/375		132				0,78	7,71	49,1	2,75	3,63
11	PLM4160B34S/3110		160	0,83	6,94	71,6	2,34	3,02			

P _N kW	Voltage U _N V										n _N min ⁻¹	Observe the regulations and codes locally in force regarding sorted waste disposal.	Operating conditions **			
	Δ			Y			Δ			Y			Altitude Above Sea Level (m)	T. amb min/max °C	ATEX	
	220 V	230 V	240 V	380 V	400 V	415 V	380 V	400 V	415 V	660 V						690 V
0,25	1,68	1,71	1,77	0,97	0,99	1,02	-	-	-	-	-	1375 ÷ 1400	≤ 1000	-15 / 40	No	
0,37	2,46	2,53	2,62	1,42	1,46	1,51	-	-	-	-	-	1355 ÷ 1380				
0,55	2,98	3,03	3,1	1,72	1,75	1,79	-	-	-	-	-	1380 ÷ 1400				
0,75	3,08	3,03	3,01	1,78	1,75	1,74	1,78	1,75	1,74	1,03	1,01	1410 ÷ 1430				
1,1	4,64	4,61	4,61	2,68	2,66	2,66	2,66	2,64	2,64	1,54	1,53	1435 ÷ 1445				
1,5	6,50	6,51	6,62	3,75	3,76	3,82	3,74	3,75	3,80	2,16	2,16	1440 ÷ 1450				
2,2	8,49	8,31	8,24	4,90	4,80	4,76	4,87	4,78	4,72	2,81	2,76	1445 ÷ 1455				
3	12,0	11,9	12,0	6,91	6,89	6,94	6,88	6,86	6,90	3,97	3,96	1455 ÷ 1465				
4	15,5	15,3	15,2	8,93	8,82	8,78	8,80	8,64	8,60	5,08	4,99	1445 ÷ 1455				
5,5	20,4	19,9	19,6	11,8	11,5	11,3	11,9	11,5	11,5	6,85	6,66	1455 ÷ 1465				
7,5	27,4	26,8	26,4	15,8	15,5	15,2	15,9	15,6	15,4	9,20	8,98	1450 ÷ 1460				
11	38,3	37,9	37,9	22,1	21,9	21,9	21,8	21,2	21,1	12,6	12,3	1465 ÷ 1470				

* R = Reduced size of motor casing as compared to shaft extension and flange.

she-ie2-mott-4p50-en_b_te

** Operating conditions to be referred to motor only. About electric pump, refer to limits in user's manual.

SHS4 SERIES (from 0,55 to 11 kW)
SHF4 SERIES (from 0,25 to 11 kW)
THREE-PHASE MOTORS AT 50 Hz, 4 POLES

P _N kW	Efficiency η_N %																		IE	Year of manufacture			
	Δ 220 V Y 380 V			Δ 230 V Y 400 V			Δ 240 V Y 415 V			Δ 380 V Y 660 V			Δ 400 V Y 690 V			Δ 415 V							
	4/4	3/4	2/4	4/4	3/4	2/4	4/4	3/4	2/4	4/4	3/4	2/4	4/4	3/4	2/4	4/4	3/4	2/4					
0,25	-	-	-	-	-	-	-	-	-	-	-	-	-	-	-	-	-	-	-	-	-	-	-
0,37	-	-	-	-	-	-	-	-	-	-	-	-	-	-	-	-	-	-	-	-	-	-	-
0,55	-	-	-	-	-	-	-	-	-	-	-	-	-	-	-	-	-	-	-	-	-	-	-
0,75	80,4	81,3	79,8	81,1	81,4	79,1	81,4	81,2	78,4	80,4	81,2	78,4	80,4	81,2	78,4	80,4	81,2	78,4	80,4	81,2	78,4	80,4	81,1
1,1	81,4	81,4	81,1	81,4	81,4	81,1	81,4	81,4	81,1	81,4	81,4	81,1	81,4	81,4	81,1	81,4	81,4	81,1	81,4	81,4	81,1	81,4	81,1
1,5	83,1	83,1	82,0	83,1	83,1	82,0	83,1	83,1	82,0	83,1	83,1	82,0	83,1	83,1	82,0	83,1	83,1	82,0	83,1	83,1	82,0	83,1	82,0
2,2	84,7	84,7	84,7	84,7	84,7	84,7	84,7	84,7	84,7	84,7	84,7	84,7	84,7	84,7	84,7	84,7	84,7	84,7	84,7	84,7	84,7	84,7	84,7
3	85,5	85,5	84,1	85,5	85,5	84,1	85,5	85,5	84,1	85,5	85,5	84,1	85,5	85,5	84,1	85,5	85,5	84,1	85,5	85,5	84,1	85,5	84,1
4	86,6	86,6	86,6	86,6	86,6	86,6	86,6	86,6	86,6	86,6	86,6	86,6	86,6	86,6	86,6	86,6	86,6	86,6	86,6	86,6	86,6	86,6	86,6
5,5	88,0	88,0	88,0	88,0	88,0	88,0	88,0	88,0	88,0	88,0	88,0	88,0	88,0	88,0	88,0	88,0	88,0	88,0	88,0	88,0	88,0	88,0	88,0
7,5	88,7	88,7	88,7	88,7	88,7	88,7	88,7	88,7	88,7	88,7	88,7	88,7	88,7	88,7	88,7	88,7	88,7	88,7	88,7	88,7	88,7	88,7	88,7
11	89,8	89,8	89,8	89,8	89,8	89,8	89,8	89,8	89,8	89,8	89,8	89,8	89,8	89,8	89,8	89,8	89,8	89,8	89,8	89,8	89,8	89,8	89,8

P _N kW	Manufacturer		IEC SIZE	Construction Design	N. of Poles	f _N Hz	Data for 400 V / 50 Hz Voltage				
	Lowara srl Unipersonale Reg. No. 03471820260 Montecchio Maggiore Vicenza - Italia						cos ϕ	I _s / I _N	T _N Nm	T _s /T _N	T _m /T _N
	Model										
0,25	SM471B3/302		71	B3	4	50	0,59	3,58	1,71	3,16	2,63
0,37	SM471B3/304		71				0,60	3,39	2,57	3,40	2,47
0,55	SM480B3/305		80	B3			0,67	3,95	3,77	2,45	2,38
	SM480B5/305			B5			0,75	5,78	5,03	2,77	3,31
0,75	LLM480B3/307		80	B3							
	LLM480B5/307		B5								
1,1	PLM490B3/311		90	B3			0,67	6,79	9,88	3,33	3,67
	PLM490B5/311			B5							
1,5	PLM490B3/315		90	B3			0,77	7,50	14,4	2,71	3,97
	PLM490B5/315			B5							
2,2	PLM4100B3/322		100	B3			0,73	7,84	19,6	2,96	4,09
	PLM4100B5/322			B5							
3	PLM4100B3/330		100	B3	0,78	7,91	26,3	2,86	3,94		
	PLM4100B5/330			B5							
4	PLM4112B3/340		112	B3	0,78	7,89	35,9	2,79	3,47		
	PLM4112B5/340			B5							
5,5	PLM4132B3/355		132	B3	0,78	7,71	49,1	2,75	3,63		
	PLM4132B5/355			B5							
7,5	PLM4132B3/375		132	B3	0,83	6,94	71,6	2,34	3,02		
	PLM4132B5/375			B5							
11	PLM4160B3/3110		160	B3							
	PLM4160B5/3110			B5							

P _N kW	Voltage U _N V											η_N min ⁻¹	Observe the regulations and codes locally in force regarding sorted waste disposal.	Operating conditions **		
	Δ			Y			Δ			Y				Altitude Above Sea Level (m)	T. amb min/max °C	ATEX
	220 V	230 V	240 V	380 V	400 V	415 V	380 V	400 V	415 V	660 V	690 V					
0,25	1,68	1,71	1,77	0,97	0,99	1,02	-	-	-	-	-	1375 ÷ 1400	≤ 1000	-15 / 40	No	
0,37	2,46	2,53	2,62	1,42	1,46	1,51	-	-	-	-	-	1355 ÷ 1380				
0,55	2,98	3,03	3,10	1,72	1,75	1,79	-	-	-	-	-	1380 ÷ 1400				
0,75	3,08	3,03	3,01	1,78	1,75	1,74	1,78	1,75	1,74	1,03	1,01	1410 ÷ 1430				
1,1	4,64	4,61	4,61	2,68	2,66	2,66	2,66	2,64	2,64	1,54	1,53	1435 ÷ 1445				
1,5	6,50	6,51	6,62	3,75	3,76	3,82	3,74	3,75	3,80	2,16	2,16	1440 ÷ 1450				
2,2	8,49	8,31	8,24	4,90	4,80	4,76	4,87	4,78	4,72	2,81	2,76	1445 ÷ 1455				
3	12,0	11,9	12,0	6,91	6,89	6,94	6,88	6,86	6,90	3,97	3,96	1455 ÷ 1465				
4	15,5	15,3	15,2	8,93	8,82	8,78	8,80	8,64	8,60	5,08	4,99	1445 ÷ 1455				
5,5	20,4	19,9	19,6	11,8	11,5	11,3	11,9	11,5	11,5	6,85	6,66	1455 ÷ 1465				
7,5	27,4	26,8	26,4	15,8	15,5	15,2	15,9	15,6	15,4	9,20	8,98	1450 ÷ 1460				
11	38,3	37,9	37,9	22,1	21,9	21,9	21,8	21,2	21,1	12,6	12,3	1465 ÷ 1470				

** Operating conditions to be referred to motor only. About electric pump, refer to limits in user's manual.

MOTOR NOISE

The tables below show the mean sound pressure levels (Lp) measured at 1 meter's distance in a free field according to the A curve (ISO 1680 standard).

The noise values are measured with idling 50 Hz motor with a tolerance of 3 dB (A).

SHE-SHS MOTORS 2 POLES 50 Hz

POWER kW	MOTOR TYPE IEC* SIZE	NOISE LpA dB
0,75	90R	<70
1,1	90R	<70
1,5	90R - 90	<70
2,2	90	<70
3	90	<70
3	100R	<70
4	112R	<70
5,5	112	<70
5,5	132R	<70
7,5	132	71
9,2	132	73
11	132	73
11	160R	73
11	160	71
15	160	71
18,5	160	73
22	160	70
22	180R	70
30	200	72
37	200	72

SHE4 MOTORS 4 POLES 50 Hz

POWER kW	MOTOR TYPE IEC* SIZE	NOISE LpA dB
0,25	71	<70
0,37	71	<70
0,55	90R	<70
0,75	90R	<70
1,1	90	<70
1,5	90	<70
2,2	100	<70
3	100	<70
4	112	<70
5,5	132	<70
7,5	132	<70
11	160	<70

*R=Reduced size of motor as compared to shaft extension and flange.

SHF MOTORS 2 POLES 50 Hz

POWER kW	MOTOR TYPE IEC SIZE	NOISE LpA dB
0,75	80	<70
1,1	80	<70
1,5	90	<70
2,2	90	<70
3	100	<70
4	112	<70
5,5	132	71
7,5	132	71
11	160	71
15	160	71
18,5	160	73
22	180	67
30	200	72
37	200	72
45	225	75
55	250	75
75	280	77

SHS4-SHF4 MOTORS 4 POLES 50 Hz

POWER kW	MOTOR TYPE IEC SIZE	NOISE LpA dB
0,25	71	<70
0,37	71	<70
0,55	80	<70
0,75	80	<70
1,1	90	<70
1,5	90	<70
2,2	100	<70
3	100	<70
4	112	<70
5,5	132	<70
7,5	132	<70
11	160	<70

she-shs-shf_mott-en_d_tr

AVAILABLE VOLTAGES SM and PLM MOTORS FOR SH SERIES, 2-POLE

P _N kW	SINGLE-PHASE								THREE-PHASE																				
	50 Hz				60 Hz				50 Hz								60 Hz				50/60 Hz								
	1 x 220-240	1 x 100	1 x 110-120	1 x 220-230	1 x 100	1 x 110-115	1 x 120-127	1 x 200-210	3 x 220-230-240/380-400-415	3 x 380-400-415/660-690	3 x 200-208/346-360	3 x 255-265/440-460	3 x 290-300/500-525	3 x 440-460/-	3 x 500-525/-	3 x 220-230/380-400	3 x 255-265-277/440-460-480	3 x 380-400/660-690	3 x 440-460-480/-	3 x 110-115/190-200	3 x 200-208/346-360	3 x 330-346/575-600	3 x 575/-	3 x 230/400 50 Hz	3 x 265/460 60 Hz	3 x 400/690 50 Hz	3 x 460/- 60 Hz		
0,75	s	-	o	s	-	o	-	o	s	o	o	o	o	o	o	s	o	o	o	o	o	o	o	o	o	o	o	o	o
1,1	s	-	o	s	-	o	-	o	s	o	o	o	o	o	o	s	o	o	o	o	o	o	o	o	o	o	o	o	o
1,5	s	-	o	s	-	o	-	o	s	o	o	o	o	o	o	s	o	o	o	o	o	o	o	o	o	o	o	o	o
2,2	s	-	o	s	-	o	-	o	s	o	o	o	o	o	o	s	o	o	o	o	o	o	o	o	o	o	o	o	o
3									s	o	o	o	o	o	o	s	o	o	o	o	o	o	o	o	o	o	o	o	o
4									o	s	o	o	o	o	o	s	o	o	o	o	o	o	o	o	o	o	o	o	o
5,5									o	s	o	o	o	o	o	s	o	o	o	o	o	o	o	o	o	o	o	o	o
7,5									o	s	o	o	o	o	o	s	o	o	o	o	o	o	o	o	o	o	o	o	o
9,2									o	s	o	o	o	o	o	s	o	o	o	o	o	o	o	o	o	o	o	o	o
11									o	s	o	o	o	o	o	s	o	o	o	o	o	o	o	o	o	o	o	o	o
15									o	s	o	o	o	o	o	s	o	o	o	o	o	o	o	o	o	o	o	o	o
18,5									o	s	o	o	o	o	o	s	o	o	o	o	o	o	o	o	o	o	o	o	o
22									o	s	o	o	o	o	o	s	o	o	o	o	o	o	o	o	o	o	o	o	o

s = Standard voltage o = voltage upon request - = Not available

sh-volt-low-en_b_te

W22 MOTORS FOR SH SERIES, 2-POLE

P _N kW	THREE-PHASE																		
	50 Hz								60 Hz				50/60 Hz						
	3 x 220-230-240/380-400-415	3 x 380-400-415/660-690	3 x 110/190	3 x 200-208/346-360	3 x 255-265/440-460	3 x 290-300/500-525	3 x 440-460/-	3 x 500-525/-	3 x 230/380	3 x 380-400/660-690	3 x 440-480/-	3 x 110-115/190-200	3 x 200-208/346-360	3 x 255-265-277/440-460-480	3 x 330-346/575-600	3 x 575/-	3 x 230/400 50 Hz	3 x 265/460 60 Hz	3 x 400/690 50 Hz
22	o	s	o	o	o	o	o	o	s	o	o	o	o	o	o	o	o	o	o
30	o	s	o	o	o	o	o	o	s	o	o	o	o	o	o	o	o	o	o
37	o	s	o	o	o	o	o	o	s	o	o	o	o	o	o	o	o	o	o
45	o	s	o	o	o	o	o	o	s	o	o	o	o	o	o	o	o	o	o
55	o	s	o	o	o	o	o	o	s	o	o	o	o	o	o	o	o	o	o
75	o	s	o	o	o	o	o	o	s	o	o	o	o	o	o	o	o	o	o

s = Standard voltage o = voltage upon request - = Not available

sh-volt-weg-en_c_te

SH SERIES PUMPS

With the “Energy using Products” (EuP 2005/32/EC) and “Energy related Products” (ErP 2009/125/EC) directives, the European Commission has established requirements for promoting the use of products with low power consumption.

Among the various products considered there are also some typologies of pumps with the characteristics defined by the specific **Regulation (EU) n. 547/2012** implementing the requirements of Directives EuP and ErP.

For end-suction close-coupled pumps (ESCC for the Regulation) and own-bearing close-coupled pumps (ESOB for the Regulation) the efficiency assessment refers to:

- just the pump and not the pump and motor assembly (electric or combustion);
- pumps with just one impeller;
- pumps with a nominal pressure PN not higher than 16 bar (1600 kPa);
- pumps with a minimum nominal flow not less than 6 m³/h;
- pumps with a maximum nominal flow at the shaft not higher than 150 kW;
- pumps designed to operate at a speed of 2900 min⁻¹ (for electric pumps this means 50 Hz 2-pole electric motors) and with a head not greater than 140 metres;
- pumps designed to operate at a speed of 1450 min⁻¹ (for electric pumps this means 50 Hz 4-pole electric motors) and with a head not greater than 90 metres;
- use with clean water at a temperature ranging from -10°C to 120°C (the test is performed with cold water at a temperature not higher than 40°C).

According to the definitions established in the Regulation, the SHE and SHS versions correspond to the “end-suction close-coupled pump” while the SHF version corresponds to the “end-suction own bearing pump”.

The Regulation also establishes the following deadlines:

from	minimum efficiency index (MEI)
1st January 2013	MEI ≥ 0,1
1st January 2015	MEI ≥ 0,4

Regulation (EU) n. 547/2012 – Annex II – point 2 (Product information requirements)

- 1) Minimum efficiency index: see the MEI column in the tables in the *Hydraulic performance* section.
- 2) “The benchmark for most efficient water pumps is MEI ≥ 0,70”.
- 3) Year of manufacture: from January 2013.
- 4) Manufacturer: Lowara srl Unipersonale - Reg. No. 03471820260 - Montecchio Maggiore, Vicenza, Italy.
- 5) Product type: see the PUMP TYPE column in the tables in the *Hydraulic performance* section.
- 6) Hydraulic pump efficiency with trimmed impeller: see η_p and ΔT columns in the tables in the *Hydraulic performance* section.
- 7) Pump performance curves, including the performance curve: see the *Operating Characteristics* graphs in the following pages.
- 8) “The efficiency of a pump with a trimmed impeller is usually lower than that of a pump with the full impeller diameter. The trimming of the impeller will adapt the pump to a fixed duty point, leading to reduced energy consumption. The minimum efficiency index (MEI) is based on the full impeller diameter”.
- 9) “The operation of this water pump with variable duty points may be more efficient and economic when controlled, for example, by the use of a variable speed drive that matches the pump duty to the system”.
- 10) Information relevant for disassembly, recycling or disposal at end-of-life: observe the current laws and by-laws governing sorted waste disposal. Consult the product operating manual.
- 11) “Designed for use below – 10 °C only”: note not applicable to these products.
- 12) “Designed for use above 120 °C only”: note not applicable to these products.
- 13) Specific instructions for pumps as per points 11 and 12: not applicable to these products.
- 14) “Information on benchmark efficiency is available at”: www.europump.org (Ecodesign section).
- 15) The benchmark efficiency graphs with MEI = 0.7 and MEI = 0.4 are available at www.europump.org/efficiencycharts (refer to “ESCC 1450 rpm”, “ESCC 2900 rpm”, “ESOB 1450 rpm”, “ESOB 2900 rpm”).

SHE-SHS-SHF SERIES
HYDRAULIC PERFORMANCE RANGE AT 50 Hz, 2 POLES

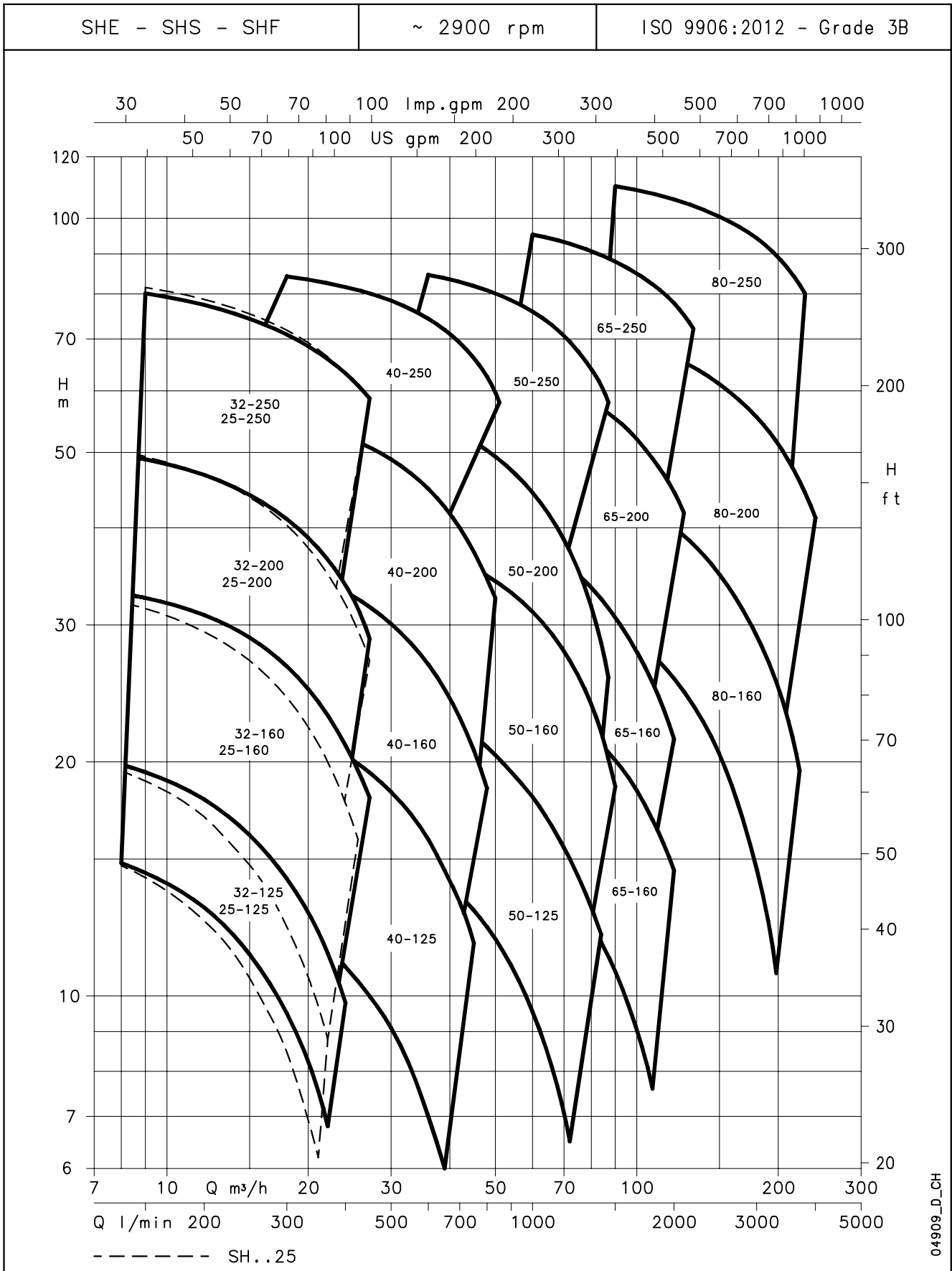

These performances are valid for liquids with density $\rho = 1,0 \text{ Kg/dm}^3$ and kinematic viscosity $\nu = 1 \text{ mm}^2/\text{sec}$.

**SHE4-SHS4-SHF4 SERIES
HYDRAULIC PERFORMANCE RANGE AT 50 Hz, 4 POLES**

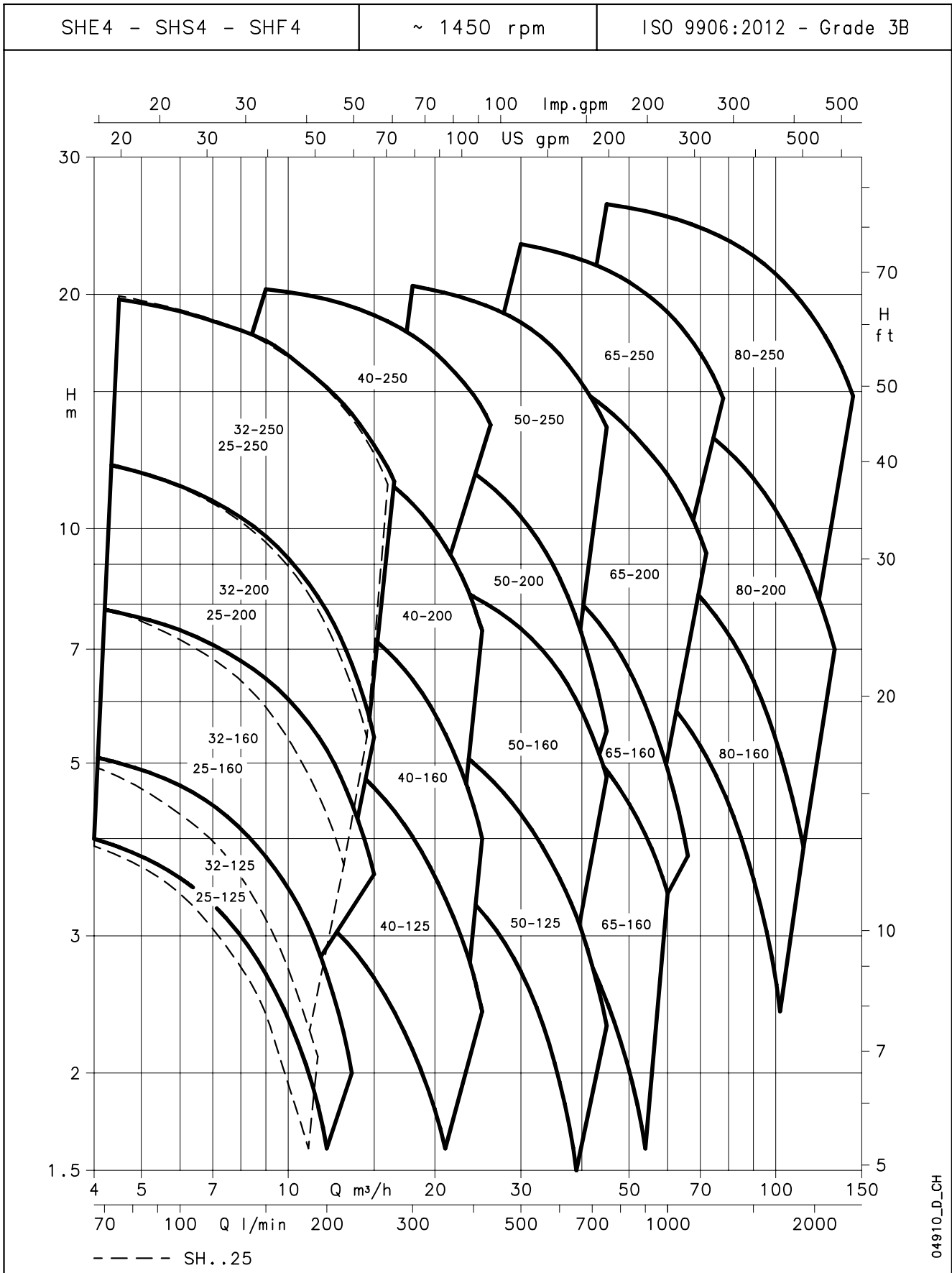

These performances are valid for liquids with density $\rho = 1,0 \text{ Kg/dm}^3$ and kinematic viscosity $\nu = 1 \text{ mm}^2/\text{sec}$.

SHE-SHS-SHF SERIES

TABLE OF HYDRAULIC PERFORMANCES AT 50 Hz, 2 POLES

PUMP TYPE	RATED POWER		MEI ≥	ØF	ηp %	ØT	Q = DELIVERY															
							Vmin 0	150	200	250	300	350	366	400	416	425	450	500				
							m³/h 0	9	12	15	18	21	22	24	25	25,5	27	30				
kW		HP	(1)	(2)	(3)	(4)	H = TOTAL HEAD METRES COLUMN OF WATER															
25-125/07 *	0,75	1	-	-	55,6	119	17,3	14,2	12,5	10,5	8,4	6,2										
25-125/11 *	1,1	1,5	0,10	136	56,5	-	22,3	18,9	17	14,7	12,3	9,7	8,8									
25-160/15 *	1,5	2	-	-	57,6	150	27,7	24,8	22,9	20,5	17,9	15	13,4	11,9								
25-160/22 *	2,2	3	0,10	164	55,4	-	34,6	31,5	29,4	27	24,2	21	20	17,7	16,5	15,9						
25-200/30	3	4	-	-	50,9	188	44,9	39,2	36,7	33,8	30,4	26,7	25,3	22,4	20,8							
25-200/40	4	5,5	0,10	204	52,9	-	54,5	49,4	46,8	43,8	40,3	36,3	34,9	31,9	30,3	29,5	27					
25-250/55	5,5	7,5	-	-	46,0	222	61,4	55,8	53,2	50,3	47	43,3	42	39,2								
25-250/75	7,5	10	-	-	44,7	242	75,9	69,3	66,5	63,2	59,6	55,6	54,1	51,1	49,6	48,7						
25-250/110	11	15	0,10	250	47,2	-	87,5	81,5	78,6	75,4	71,8	67,8	66,3	63,3	61,7	60,4	58,4					

PUMP TYPE	RATED POWER		MEI ≥	ØF	ηp %	ØT	Q = DELIVERY															
							Vmin 0	150	200	250	300	366	400	416	425	450	500	550				
							m³/h 0	9	12	15	18	22	24	25	25,5	27	30	33				
kW		HP	(1)	(2)	(3)	(4)	H = TOTAL HEAD METRES COLUMN OF WATER															
32-125/07 *	0,75	1	-	-	54,9	119	16,6	14,4	13	11,3	9,5	6,8										
32-125/11 *	1,1	1,5	0,10	136	58,2	-	21,6	19,4	17,9	16,1	14,2	11,3	9,8									
32-160/15 *	1,5	2	-	-	57,8	150	27,6	24,6	22,7	20,6	18,1	14,5	12,7									
32-160/22 *	2,2	3	0,10	164	57,4	-	35,0	32,5	30,9	28,9	26,5	23	21	20	19,5	18						
32-200/30	3	4	-	-	50,5	188	43,7	38,5	35,9	33,1	29,9	25,2	22,5	21								
32-200/40	4	5,5	0,10	204	51,4	-	53,5	49	46,8	44,1	41	36,4	33,8	32,3	31,5	28,8						
32-250/55	5,5	7,5	-	-	46,9	222	61,7	56,7	54,2	51,2	47,9	42,8	40									
32-250/75	7,5	10	-	-	45,5	242	74,1	68,9	66,2	63,2	59,9	55	52,2	50,8	50,1							
32-250/110	11	15	0,10	256	47,1	-	86,2	80,1	77,4	74,3	70,9	65,9	63,2	61,7	61	58,7						

PUMP TYPE	RATED POWER		MEI ≥	ØF	ηp %	ØT	Q = DELIVERY															
							Vmin 0	300	400	500	600	650	700	750	766	800	833	850				
							m³/h 0	18	24	30	36	39	42	45	46	48	50	51				
kW		HP	(1)	(2)	(3)	(4)	H = TOTAL HEAD METRES COLUMN OF WATER															
40-125/11 *	1,1	1,5	-	-	64,5	112	14,4	12,5	10,9	9	7	6										
40-125/15 *	1,5	2	-	-	66,0	122	17,5	16	14,4	12,4	10,2	9,1	8									
40-125/22 *	2,2	3	0,10	143	68,0	-	25,3	22,2	20,4	18,3	15,9	14,5	13,2	11,7								
40-160/30	3	4	-	-	67,5	159	32,2	29,5	26,9	24	20,8	19	17,1	15								
40-160/40	4	5,5	0,10	171	69,5	-	38,0	35,5	33,1	30,1	26,7	24,8	22,8	20,7	20	18,5						
40-200/55	5,5	7,5	-	-	66,5	190	49,1	46,4	43,7	40,3	36,2	33,7	31	28,1	27,1	25						
40-200/75	7,5	10	0,10	209	65,0	-	58,2	55,1	52,4	49	44,9	42,6	40	37,2	36,3	34,4	32,5					
40-250/ **	**	**	-	-	59,0	218	64,9	62	59,5	56,2	51,6	48,4	44,6									
40-250/110	11	15	-	-	58,5	233	74,7	71,4	68,9	66	61,4	58,6	55,2	51,3	49,8							
40-250/150	15	20	0,10	251	58,0	-	87,7	84,2	81,6	78,4	74,3	71,9	69,2	66,1	65	62,6	59,7	58				

* A single-phase version (SHEM) is also available

sh-25-32-40_2p50-en_f_th

** SHE: ..92 = 9,2kW (12,5 HP); SHS, SHF: ..110A = 11kW (15 HP)

Hydraulic performances in compliance with ISO 9906:2012 - Grade 3B (ex ISO 9906:1999 - Annex A)

(1) MEI Minimal Efficiency Index (2) External diameter of full impeller (3) Hydraulic efficiency of pump (4) External diameter of trimmed impeller

SHE-SHS-SHF SERIES

TABLE OF HYDRAULIC PERFORMANCES AT 50 Hz, 2 POLES

PUMP TYPE	RATED POWER		MEI \geq	$\varnothing F$	η_p %	$\varnothing T$	Q = DELIVERY																	
							V_{min} 0	600	700	800	900	1000	1100	1200	1300	1383	1400	1450	1500					
							m ³ /h 0	36	42	48	54	60	66	72	78	82,98	84	87	90					
H = TOTAL HEAD METRES COLUMN OF WATER																								
50-125/22 *	2,2	3	-	-	72,5	119	17,2	14,6	13,5	12,3	10,9	9,5	8,1	6,5										
50-125/30	3	4	-	-	73,5	130	21,7	18,8	17,6	16,3	14,9	13,4	12	10,5	9									
50-125/40	4	5,5	0,10	139	75,0	-	25,7	23,3	22,2	20,9	19,4	18	16,5	15	13,5	12,2	12							
50-160/55	5,5	7,5	-	-	72,0	158	34,1	30,6	29,2	27,6	25,9	24	22	19,9	17,4	15,2	14,7							
50-160/75	7,5	10	0,10	174	74,0	-	40,8	37,5	36,2	34,7	33	31,2	29,2	27	24,6	22,3	21,8	20,2	18,6					
50-200/ **	**	**	-	-	70,0	197	53,0	47,5	45,3	42,8	40	36,9	33,5	29,8	25,5	21,6	20,7							
50-200/110	11	15	0,10	209	72,0	-	60,1	55	52,8	50,3	47,5	44,4	41	37,3	33,2	29,3	28,4	25,7						
50-250/150	15	20	-	-	69,5	224	70,2	66,6	65	63,2	61	58,3	55,1	50,8	45,6									
50-250/185	18,5	25	-	-	68,4	327	80,0	75	73,3	71,3	69	66,4	63,3	59,6	55,2	50,8								
50-250/220	22	30	0,10	250	67,3	-	88,9	84,6	82,8	80,8	78,5	75,9	72,9	69,4	65,4	61,8	61	58						

PUMP TYPE	RATED POWER		MEI \geq	$\varnothing F$	η_p %	$\varnothing T$	Q = DELIVERY																	
							V_{min} 0	800	900	1000	1200	1400	1600	1800	1900	2000	2100	2200	2600					
							m ³ /h 0	48	54	60	72	84	96	108	114	120	126	132	156					
H = TOTAL HEAD METRES COLUMN OF WATER																								
65-160/40	4	5,5	-	-	69,5	119,5/114,5	19,6	16,8	16	15,2	13,5	11,7	9,7	7,6										
65-160/55	5,5	7,5	-	-	71,5	129	24,2	21,4	20,6	19,8	18	16,1	14,1	11,8	10,6									
65-160/75	7,5	10	0,10	137	72,5	-	28,2	26	25,3	24,5	22,9	21	19,1	16,9	15,7	14,5								
65-160/ **	**	**	-	-	75,0	168	38,2	35,4	34,3	33	30,1	27	23,7	20,1	18,1									
65-160/110	11	15	0,10	177	74,0	-	43,2	40,8	39,7	38,5	35,6	32,4	28,9	25,3	23,4	21,4								
65-200/150	15	20	-	-	70,0	192	53,0	48,8	47,5	44,3	40,6	36,4	32	29,3										
65-200/185	18,5	25	-	-	71,5	203	60,2	56,5	55,2	52,2	48,7	44,7	40,2	38	35,4									
65-200/220	22	30	0,10	215	70,5	-	68,0	64,4	63,1	60,2	57	53,4	49,1	46,9	44,5	41,8								
65-250/300	30	40	-	-	74,5	240	84,3	81,7	79,6	76,7	73,4	69,2	66,8	64,2	61,3									
65-250/370	37	50	0,10	255	73,5	-	98,0	95,3	92,8	89,7	86,2	82,3	80,2	77,8	75,1	72,1								

PUMP TYPE	RATED POWER		MEI \geq	$\varnothing F$	η_p %	$\varnothing T$	Q = DELIVERY																	
							V_{min} 0	1200	1500	1800	2000	2400	2800	3300	3500	3600	3700	3800	4000					
							m ³ /h 0	72	90	108	120	144	168	198	210	216	222	228	240					
H = TOTAL HEAD METRES COLUMN OF WATER																								
80-160/110	11	15	-	-	75,0	169x15°	33,6	31,9	30	27,5	25,6	21,5	16,9	10,7										
80-160/150	15	20	-	-	76,5	177	40,3	38,8	37	34,6	32,7	28,6	24,1	17,7	15									
80-160/185	18,5	25	0,10	186	78,0	-	47,2	45,7	43,9	41,7	40	35,9	31,4	25,4	22,6	21,1	19,5							
80-200/220	22	30	-	-	80,5	198	53,0	49,8	47,5	45,8	41,8	37,5	31,3	28,5	27									
80-200/300	30	40	-	-	81,0	215	63,6	61,2	59	57,3	53,3	48,8	42,3	39,5	38,1	36,6	35,1							
80-200/370	37	50	0,10	226	81,5	-	71,4	69,5	67,7	66,2	62,3	57,8	51,7	48,9	47,4	45,9	44,4	41,2						
80-250/450***	45	60	-	-	79,5	237	83,5	80,5	78	76	71,2	65,9	57,7	53,7	51,5									
80-250/550***	55	75	-	-	80,0	252	95,7	93,6	91	89	84,6	79,9	72,1	68,4	66,5	64,6								
80-250/750***	75	100	0,10	270	78,0	-	112,0	110	108	106	102	96,9	89,7	86,2	84,2	82,1	80							

* A single-phase version (SHEM) is also available

sh-50-65-80_2p50-en_f_th

** SHE: ..92 = 9,2kW (12,5 HP); SHS, SHF: ../110A = 11kW (15 HP)

*** Only available in the SHF version

Hydraulic performances in compliance with ISO 9906:2012 - Grade 3B (ex ISO 9906:1999 - Annex A)

(1) MEI Minimum Efficiency Index (2) External diameter of full impeller (3) Hydraulic efficiency of pump (4) External diameter of trimmed impeller

SHE4-SHS4-SHF4 SERIES TABLE OF HYDRAULIC PERFORMANCES AT 50 Hz, 4 POLES

PUMP TYPE	RATED POWER		MEI Δ	ΦF	ηp %	ΦT	Q = DELIVERY																
							H = TOTAL HEAD METRES COLUMN OF WATER																
							l/min 0	75	100	125	150	183	191	200	216	225	241	250	266	275			
m ³ /h 0	4,5	6	7,5	9	10,98	11,5	12	12,96	13,5	14,5	15	15,96	16,5										
25-125/02A *	0,25	0,33	-	-	55,1	119	4,4	3,8	3,4	2,9	2,4	1,6											
25-125/02 *	0,25	0,33	0,10	136	53,6	-	5,6	4,8	4,3	3,8	3,2	2,3	2,1										
25-160/02 *	0,25	0,33	-	-	57,5	150	6,9	6,1	5,6	5,1	4,4	3,4	3,2	2,9									
25-160/03 *	0,37	0,5	0,10	164	55,2	-	8,6	7,8	7,2	6,6	5,9	4,9	4,6	4,3	3,7								
25-200/03 *	0,37	0,5	-	-	50,9	188	11,0	9,4	8,7	8	7,1	5,8	5,4	5,1	4,3	3,9							
25-200/05 *	0,55	0,75	0,10	204	52,8	-	13,4	12	11,3	10,5	9,6	8,3	7,9	7,5	6,7	6,3	5,4						
25-250/07	0,75	1	-	-	46,0	222	14,9	13,3	12,6	11,9	11	9,7	9,4	9	8,3	7,9	7,1	6,7					
25-250/11	1,1	1,5	-	-	44,5	242	18,8	17,1	16,3	15,5	14,6	13,2	12,8	12,4	11,6	11,2	10,3	9,9	8,9				
25-250/15	1,5	2	0,10	256	47,1	-	21,5	19,9	19,1	18,3	17,3	15,8	15,5	15,1	14,3	13,9	13,1	12,6	11,8	11,4			

PUMP TYPE	RATED POWER		MEI Δ	ΦF	ηp %	ΦT	Q = DELIVERY																
							H = TOTAL HEAD METRES COLUMN OF WATER																
							l/min 0	75	100	125	150	175	200	225	250	266	275	300	350	400			
m ³ /h 0	4,5	6	7,5	9	10,5	12	13,5	15	16	16,5	18	21	24										
32-125/02A *	0,25	0,33	-	-	56,5	119	4,4	3,9	3,6	3,1	2,7	2,2	1,6										
32-125/02 *	0,25	0,33	0,10	136	58,9	-	5,5	5	4,7	4,3	3,8	3,3	2,7	2									
32-160/02 *	0,25	0,33	-	-	56,4	150	6,9	5,9	5,4	4,9	4,4	3,7	2,9										
32-160/03 *	0,37	0,5	0,10	164	59,2	-	8,6	7,8	7,4	6,9	6,4	5,8	5,2	4	3,6								
32-200/03 *	0,37	0,5	-	-	48,2	188	10,8	9,4	8,7	7,9	7	6,1	5,1	3,9									
32-200/05 *	0,55	0,75	0,10	204	50,5	-	13,2	12	11,3	10,6	9,8	8,8	7,8	6,7	5,4								
32-250/07	0,75	1	-	-	43,7	222	14,5	13	12,3	11,6	10,8	9,9	8,9	7,7	6,5								
32-250/11	1,1	1,5	-	-	44,7	242	18,4	16,8	16,1	15,3	14,4	13,5	12,5	11,4	10,1	9,3							
32-250/15	1,5	2	0,10	256	45,2	-	21,3	19,7	19	18,2	17,5	16,3	15,2	14	12,8	12	11,5						

PUMP TYPE	RATED POWER		MEI Δ	ΦF	ηp %	ΦT	Q = DELIVERY																
							H = TOTAL HEAD METRES COLUMN OF WATER																
							l/min 0	150	175	200	225	250	300	350	366	400	416	433	450	500			
m ³ /h 0	9	10,5	12	13,5	15	18	21	21,96	24	25	25,98	27	30										
40-125/02A *	0,25	0,33	-	-	60,0	112	3,5	3	2,9	2,7	2,5	2,3	1,8	1,3									
40-125/02 *	0,25	0,33	-	-	68,1	135	5,4	4,8	4,6	4,4	4,1	3,9	3,3	2,7	2,4	2							
40-125/03 *	0,37	0,5	0,10	143	68,8	-	6,3	5,7	5,5	5,2	4,9	4,7	4	3,3	3,1	2,7	2,4						
40-160/03 *	0,37	0,5	-	-	67,6	159	8,0	7,2	6,9	6,6	6,3	5,9	5,1	4,2	3,8	3,1							
40-160/05 *	0,55	0,75	0,10	171	66,5	-	9,2	8,5	8,2	7,9	7,6	7,2	6,4	5,4	5,1	4,4	4						
40-200/07	0,75	1	-	-	64,3	190	11,9	11,2	10,9	10,5	10,1	9,6	8,6	7,3	6,8	5,8							
40-200/11	1,1	1,5	0,10	209	62,9	-	14,2	13,3	13	12,7	12,3	11,8	10,8	9,5	9	8	7,4						
40-250/11	1,1	1,5	-	-	55,8	218	15,7	14,6	14,3	13,9	13,5	13	11,9	10,3	9,7								
40-250/15	1,5	2	-	-	57,0	233	18,1	17	16,7	16,4	16	15,5	14,5	13,1	12,5	11,4							
40-250/22	2,2	3	0,10	251	58,1	-	21,5	20,3	20	19,7	19,3	18,8	17,7	16,3	15,9	14,9	14,3	13,6					

* SHS4 version is not available.

sh4-25-32-40_4p50-en_g_th

Hydraulic performances in compliance with ISO 9906:2012 - Grade 3B (ex ISO 9906:1999 - Annex A)

(1) MEI Minimum Efficiency Index (2) External diameter of full impeller (3) Hydraulic efficiency of pump (4) External diameter of trimmed impeller

SHE4-SHS4-SHF4 SERIES

TABLE OF HYDRAULIC PERFORMANCES AT 50 Hz, 4 POLES

PUMP TYPE	RATED POWER		MEI ±	ØF	ηp %	ØT	Q = DELIVERY																			
							l/min 0	300	350	400	450	500	550	600	650	700	725	750	800	900						
							m³/h 0	18	21	24	27	30	33	36	39	42	43,5	45	48	54						
							H = TOTAL HEAD METRES COLUMN OF WATER																			
50-125/03A *	0,37	0,5	-	-	72,1	119	4,4	3,8	3,6	3,3	3	2,7	2,3	1,9	1,5											
50-125/03 *	0,37	0,5	-	-	73,3	130	5,4	4,6	4,3	4	3,7	3,3	3	2,6	2,2	1,8										
50-125/05 *	0,55	0,75	0,10	139	74,2	-	6,4	5,6	5,3	5	4,7	4,3	3,9	3,6	3,2	2,7	2,5	2,3								
50-160/07	0,75	1	-	-	71,3	158	8,2	7,3	7	6,6	6,3	5,9	5,4	4,9	4,4	3,8										
50-160/11	1,1	1,5	0,10	174	73,0	-	9,9	8,8	8,5	8,2	7,8	7,4	7	6,5	6	5,4	5,1	4,8								
50-200/11	1,1	1,5	-	-	69,1	197	12,8	11,2	10,6	10	9,3	8,6	7,7	6,8	5,8	4,8										
50-200/15	1,5	2	0,10	209	70,1	-	14,7	13	12,4	11,8	11,1	10,4	9,5	8,6	7,7	6,6	6,1	5,5								
50-250/22A	2,2	3	-	-	70,0	224	17,5	16	15,5	15	14,4	13,8	13	12,1	11	9,7										
50-250/22	2,2	3	-	-	69,0	237	19,4	17,8	17,3	16,8	16,2	15,5	14,7	13,8	12,8	11,6	10,9									
50-250/30	3	4	0,10	250	67,9	-	21,9	20,5	20	19,6	19	18,4	17,6	16,8	15,7	14,7	14,1	13,5								

PUMP TYPE	RATED POWER		MEI ±	ØF	ηp %	ØT	Q = DELIVERY																			
							l/min 0	400	450	500	600	700	800	900	950	1000	1100	1200	1300	1400						
							m³/h 0	24	27	30	36	42	48	54	57	60	66	72	78	84						
							H = TOTAL HEAD METRES COLUMN OF WATER																			
65-160/05	0,55	0,75	-	-	67,3	119,5/114,5	5,4	4,2	4	3,7	3,2	2,7	2,2	1,6												
65-160/07	0,75	1	-	-	69,3	129	6,4	5,3	5,1	4,8	4,4	3,9	3,4	2,8	2,4											
65-160/11A	1,1	1,5	0,10	139,5	70,2	-	7,6	6,5	6,3	6,1	5,6	5,2	4,6	4,1	3,7	3,4										
65-160/11	1,1	1,5	-	-	72,7	168	9,4	8,5	8,2	7,9	7,2	6,4	5,4	4,4	3,9	3,4										
65-160/15	1,5	2	0,10	177	71,6	-	10,6	9,7	9,4	9,2	8,5	7,8	6,9	5,9	5,4	4,9	3,8									
65-200/15	1,5	2	-	-	67,4	187	11,9		10,6	10,2	9,4	8,4	7,4	6,3	5,7	5,1										
65-200/22	2,2	3	-	-	68,9	203	14,4		13,2	12,8	12	11,1	10	9	8,4	7,8	6,6									
65-200/30	3	4	0,10	222	70,5	-	17,5		16,6	16,3	15,6	14,7	13,7	12,7	12,2	11,7	10,6	9,3								
65-250/40	4	5,5	-	-	71,9	240	20,7			19,5	18,9	18,1	17,2	16,3	15,7	15,1	13,7	12								
65-250/55	5,5	7,5	0,10	255	71,0	-	24,0			23,2	22,6	21,9	21	20	19,5	19	17,7	16,3	14,7							

PUMP TYPE	RATED POWER		MEI ±	ØF	ηp %	ØT	Q = DELIVERY																			
							l/min 0	600	750	1000	1200	1400	1600	1700	1800	1900	2000	2100	2200	2400						
							m³/h 0	36	45	60	72	84	96	102	108	114	120	126	132	144						
							H = TOTAL HEAD METRES COLUMN OF WATER																			
80-160/15	1,5	2	-	-	75,2	169x15°	8,3	7,6	7,1	6	5,1	4,1	3	2,4												
80-160/22A	2,2	3	-	-	74,2	177	9,6	9	8,5	7,5	6,5	5,5	4,4	3,8	3,2											
80-160/22	2,2	3	0,10	186	73,4	-	11,0	10,4	9,9	8,9	8	7	5,8	5,1	4,5	3,9										
80-200/30	3	4	-	-	80,5	198	12,9		12	10,9	9,8	8,6	7,4	6,8	6,1	5,4	4,6									
80-200/40	4	5,5	0,10	220	78,3	-	16,1		15,4	14,3	13,3	12,2	11	10,3	9,7	9	8,4	7,7	7							
80-250/55	5,5	7,5	-	-	77,5	237	20,3		19,5	18,5	17,3	16	14,3	13,4	12,3	11,3	10,2	9								
80-250/75	7,5	1	-	-	76,7	252	23,1		22,2	21,3	20,3	19,1	17,7	16,9	16,1	15,2	14,3	13,2	12,2							
80-250/110	11	15	0,10	270	74,3	-	26,7		26,1	25,2	24,2	23	21,7	21	20,2	19,4	18,6	17,7	16,8	14,8						

* SHS4 version is not available.

sh4-50-65-80_4p50-en_g_th

Hydraulic performances in compliance with ISO 9906:2012 - Grade 3B (ex ISO 9906:1999 - Annex A)

(1) MEI Minimum Efficiency Index (2) External diameter of full impeller (3) Hydraulic efficiency of pump (4) External diameter of trimmed impeller

SH SERIES IDENTIFICATION OF IMPELLER TYPOLOGY

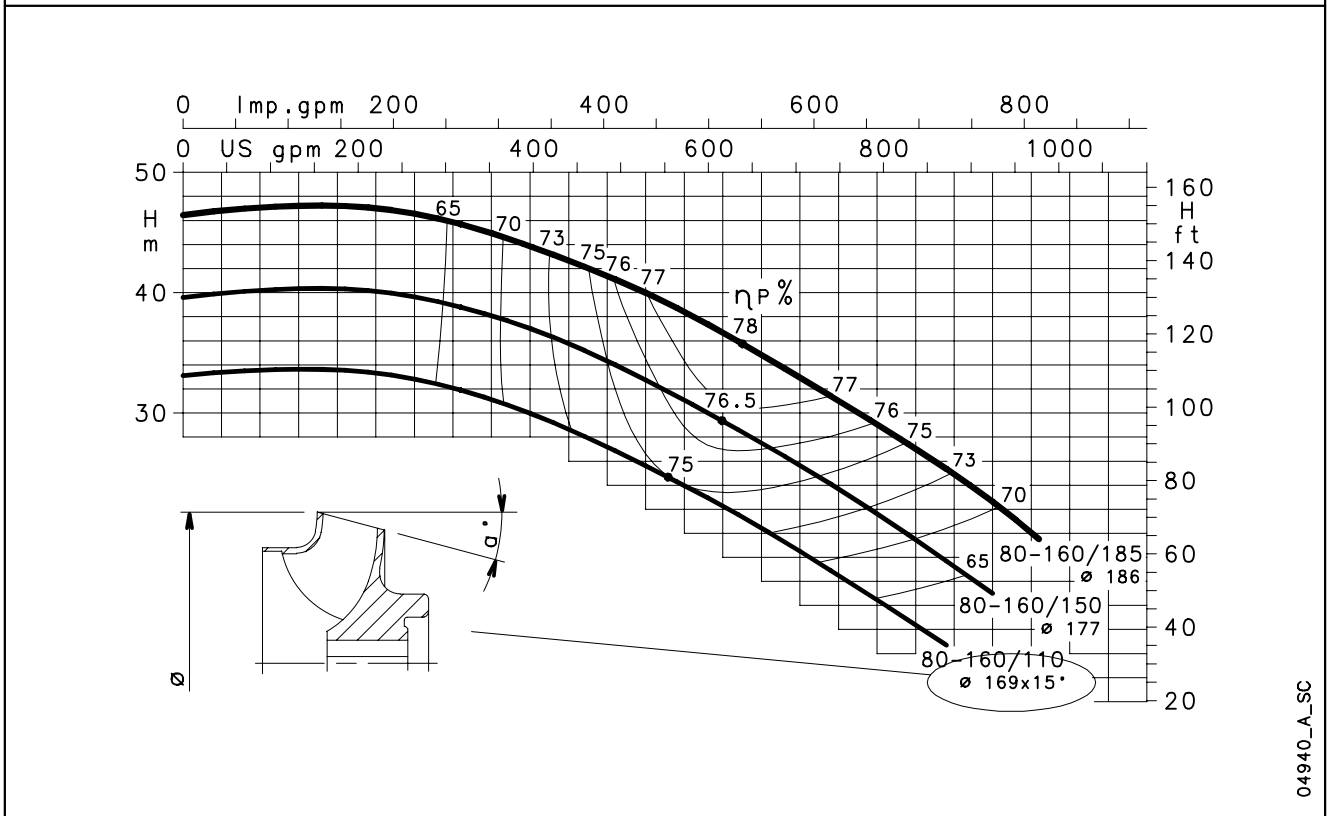
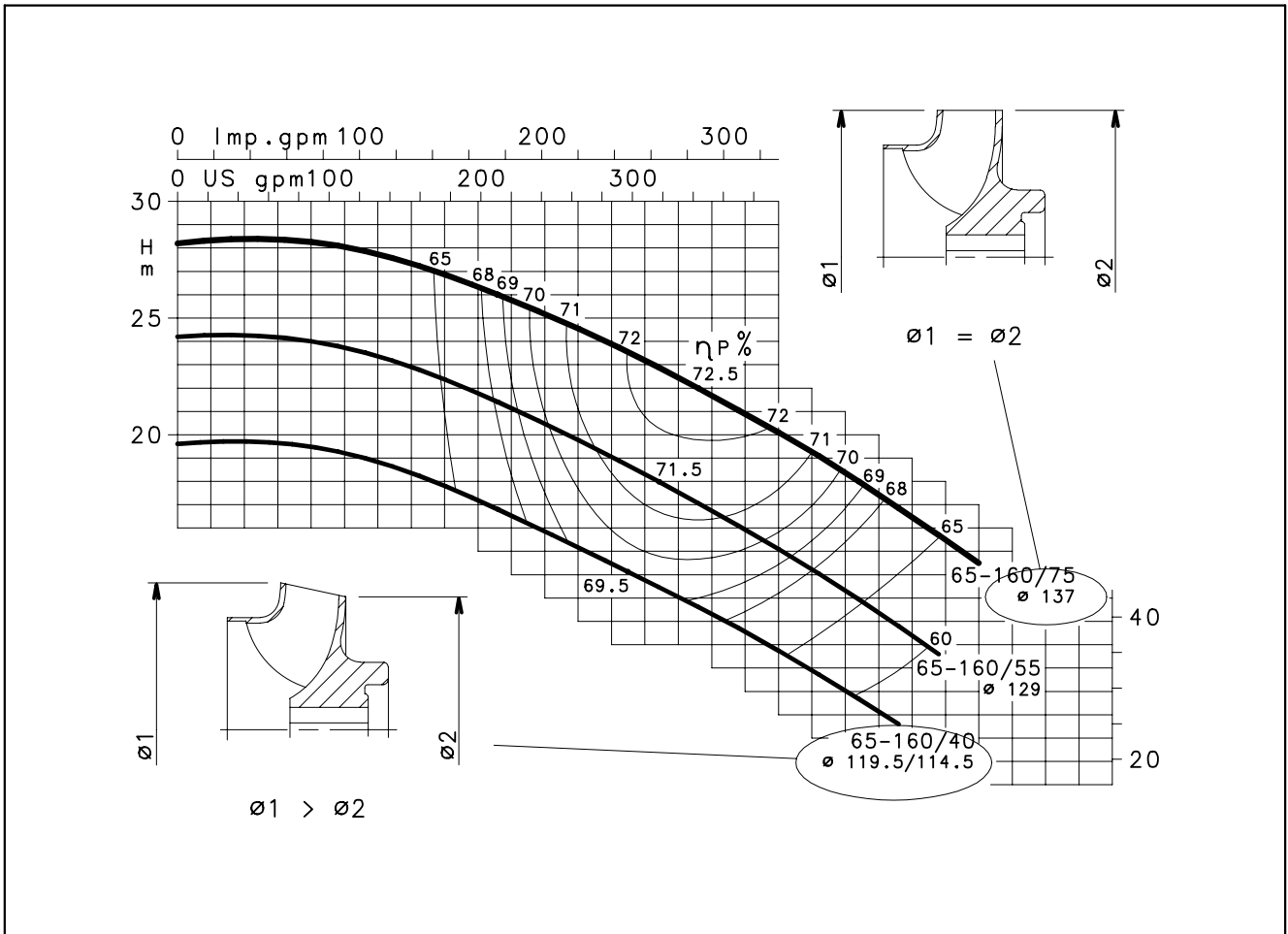

**SHE-SHS-SHF SERIES
OPERATING CHARACTERISTICS AT 50 Hz, 2 POLES**

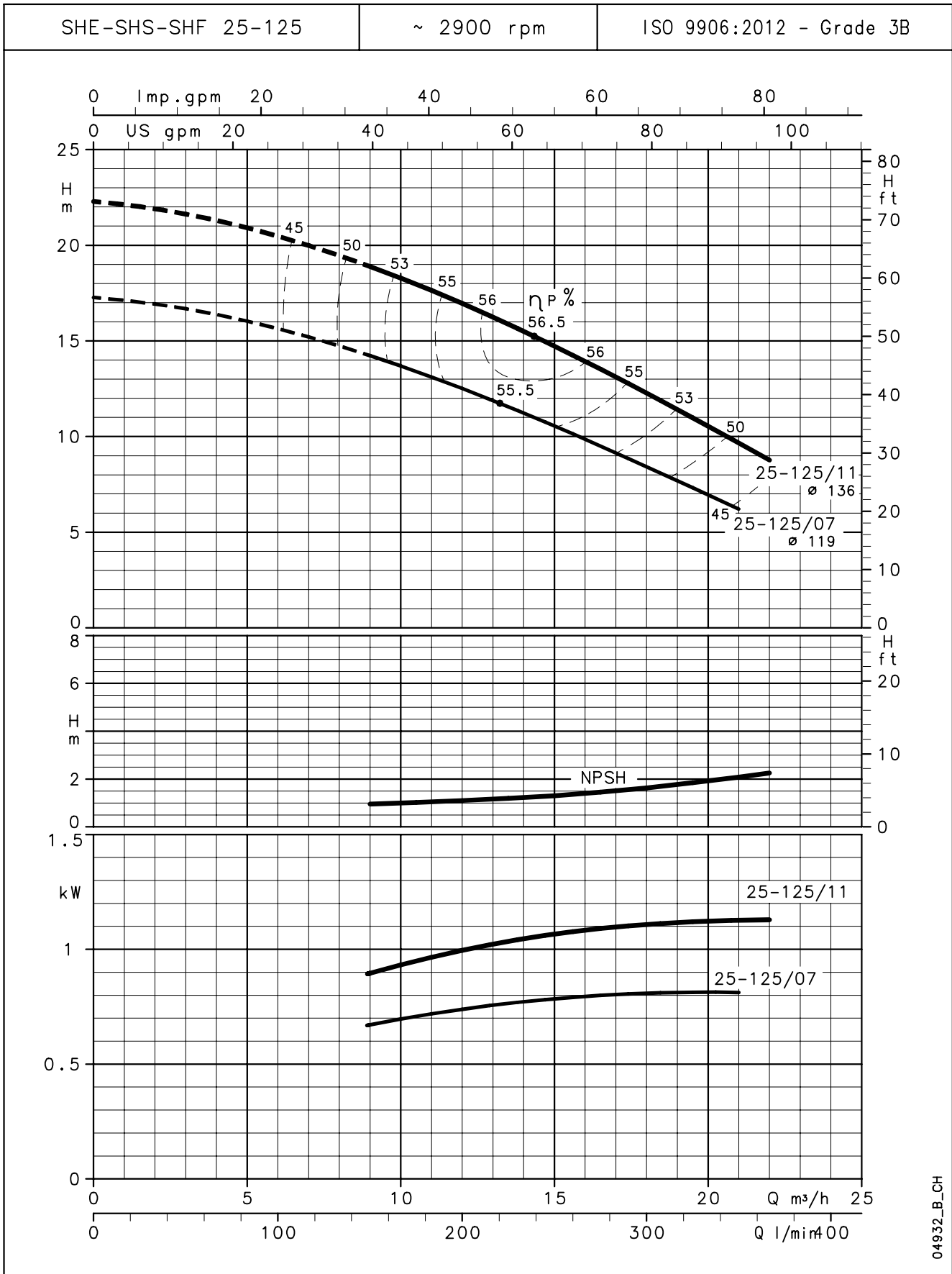

04932_B_CH

The NPSH values are laboratory values; for practical use we suggest increasing these values by 0,5 m.
These performances are valid for liquids with density $\rho = 1,0 \text{ Kg/dm}^3$ and kinematic viscosity $\nu = 1 \text{ mm}^2/\text{sec}$.

**SHE-SHS-SHF SERIES
OPERATING CHARACTERISTICS AT 50 Hz, 2 POLES**

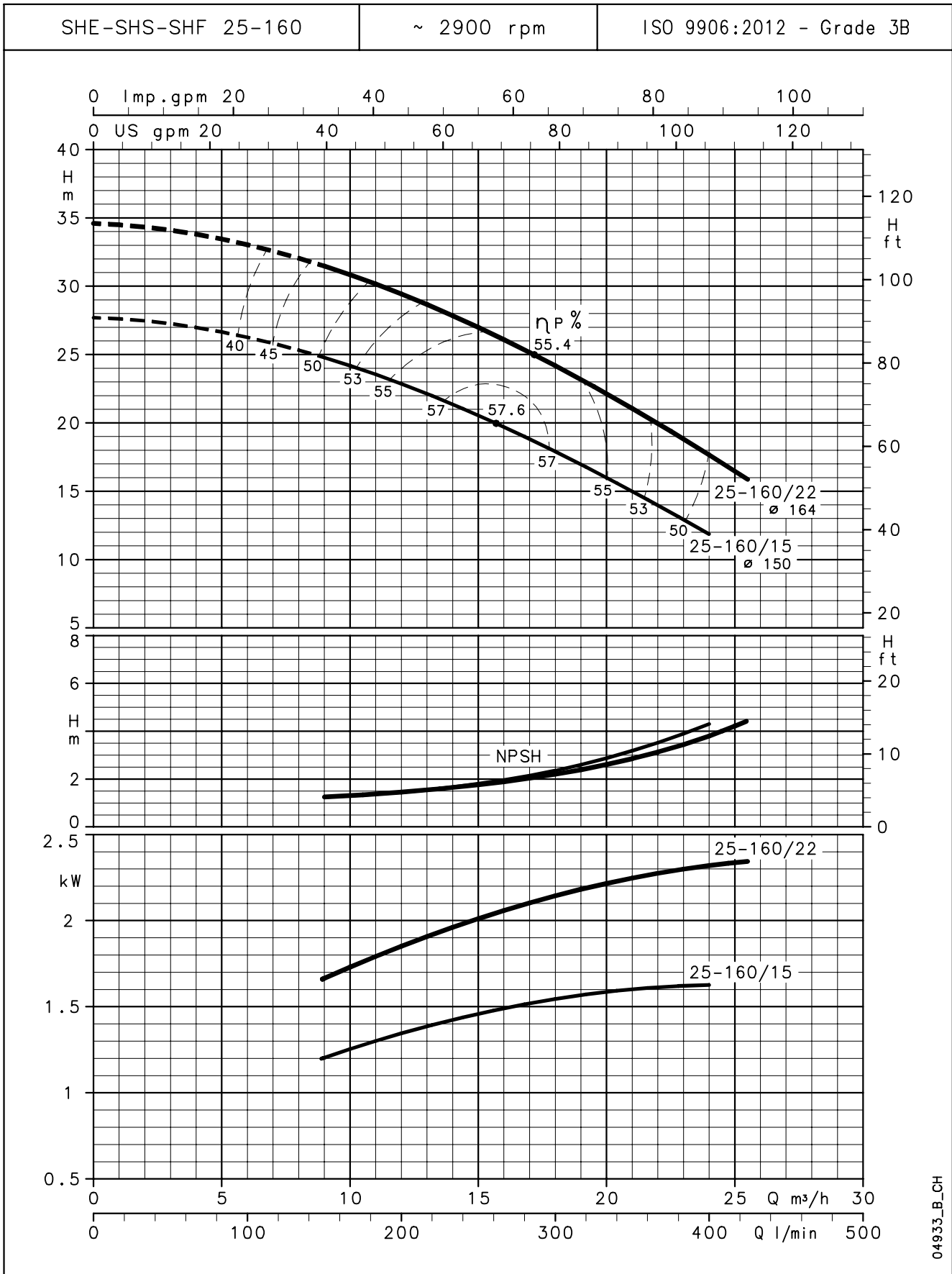

04933_B_CH

The NPSH values are laboratory values; for practical use we suggest increasing these values by 0,5 m.
These performances are valid for liquids with density $\rho = 1,0 \text{ Kg/dm}^3$ and kinematic viscosity $\nu = 1 \text{ mm}^2/\text{sec}$.

**SHE-SHS-SHF SERIES
OPERATING CHARACTERISTICS AT 50 Hz, 2 POLES**

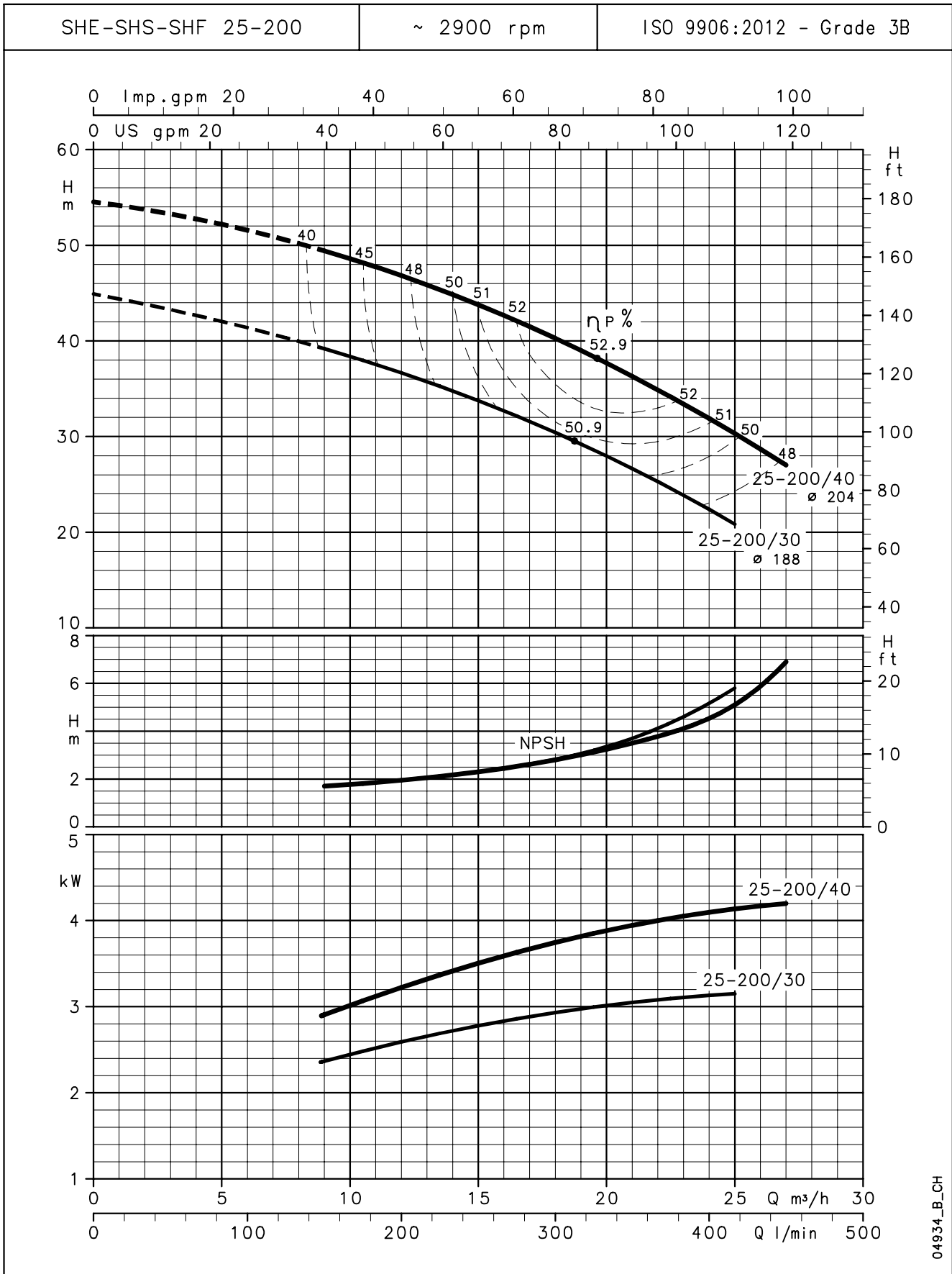

04934_B_CH

The NPSH values are laboratory values; for practical use we suggest increasing these values by 0,5 m.
These performances are valid for liquids with density $\rho = 1,0 \text{ Kg/dm}^3$ and kinematic viscosity $\nu = 1 \text{ mm}^2/\text{sec}$.

SHE-SHS-SHF SERIES
OPERATING CHARACTERISTICS AT 50 Hz, 2 POLES

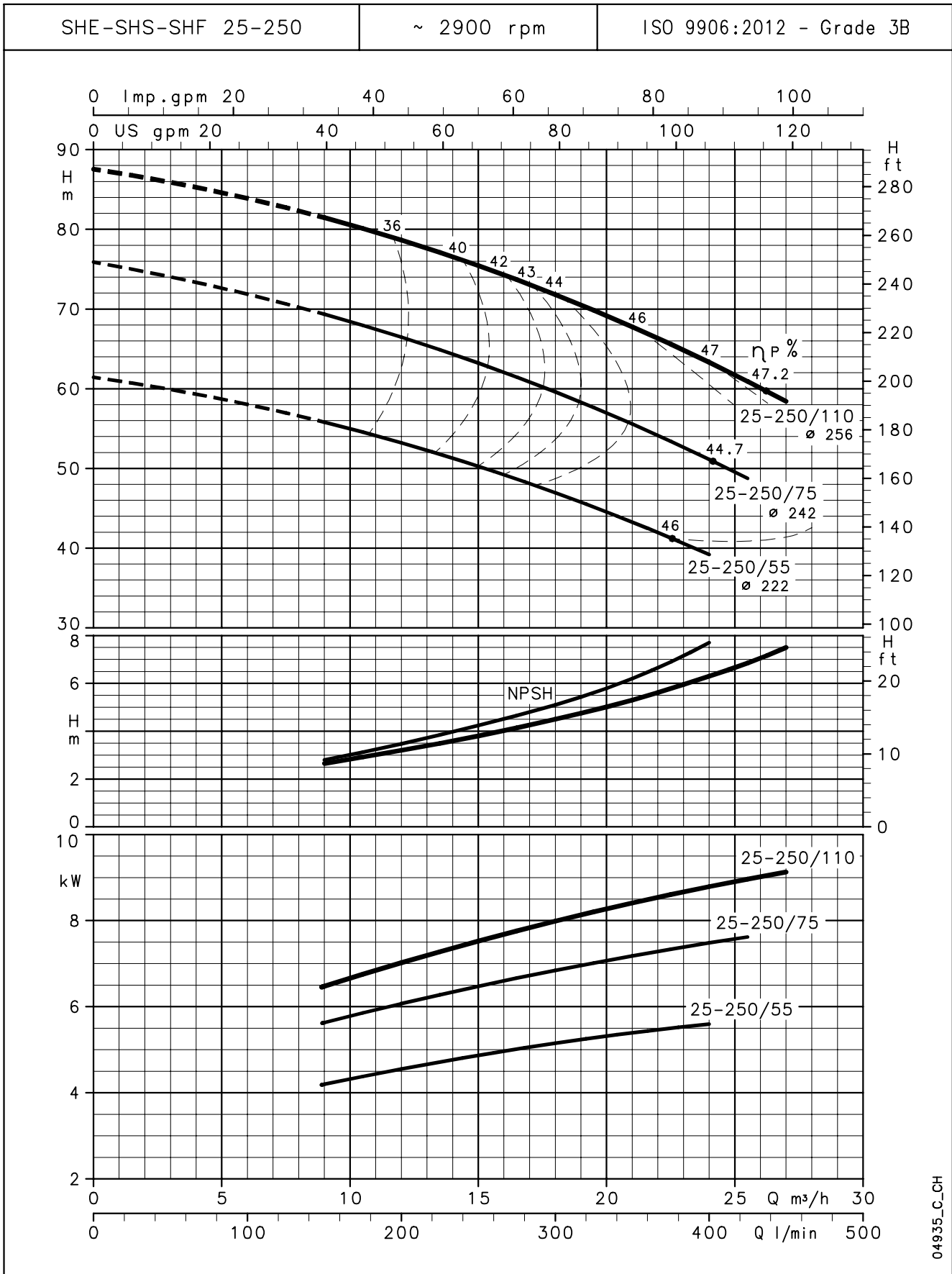

04935_C_CH

The NPSH values are laboratory values; for practical use we suggest increasing these values by 0,5 m.
 These performances are valid for liquids with density ρ = 1,0 Kg/dm³ and kinematic viscosity ν = 1 mm²/sec.

SHE-SHS-SHF SERIES
OPERATING CHARACTERISTICS AT 50 Hz, 2 POLES

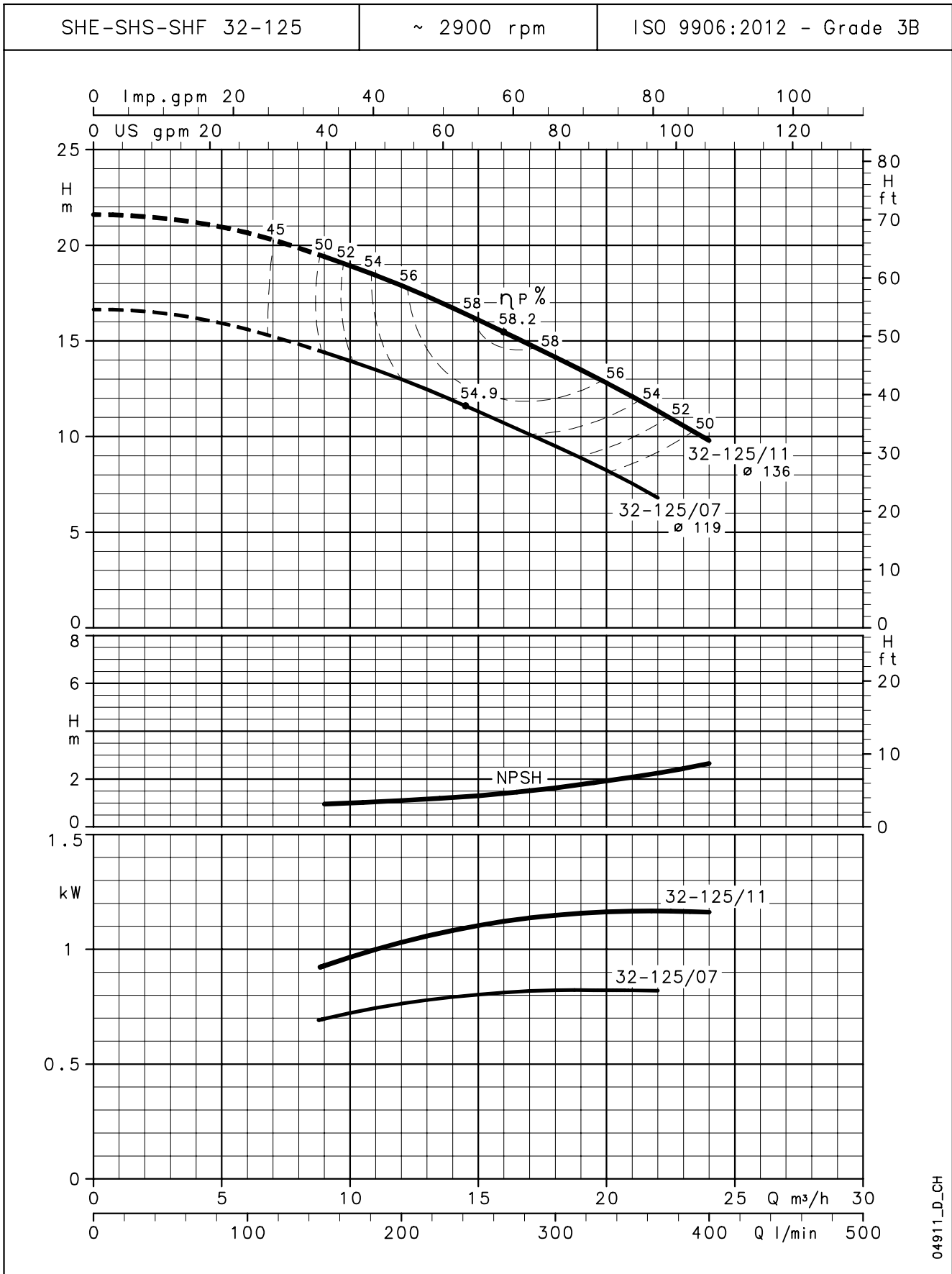

04911_D_CH

The NPSH values are laboratory values; for practical use we suggest increasing these values by 0,5 m.
These performances are valid for liquids with density $\rho = 1,0 \text{ Kg/dm}^3$ and kinematic viscosity $\nu = 1 \text{ mm}^2/\text{sec}$.

SHE-SHS-SHF SERIES
OPERATING CHARACTERISTICS AT 50 Hz, 2 POLES

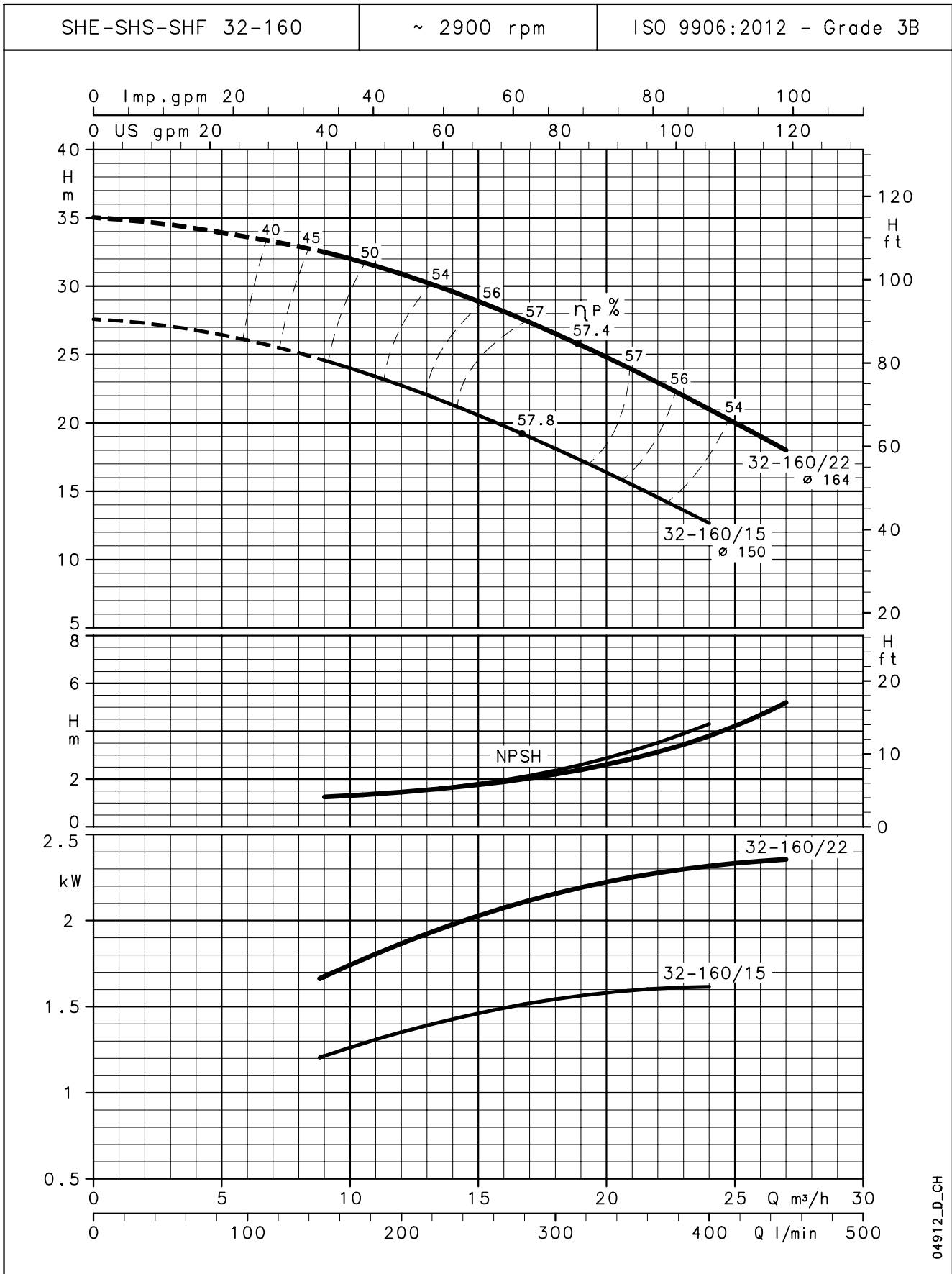

04912_D_CH

The NPSH values are laboratory values; for practical use we suggest increasing these values by 0,5 m.
These performances are valid for liquids with density $\rho = 1,0 \text{ Kg/dm}^3$ and kinematic viscosity $\nu = 1 \text{ mm}^2/\text{sec}$.

SHE-SHS-SHF SERIES OPERATING CHARACTERISTICS AT 50 Hz, 2 POLES

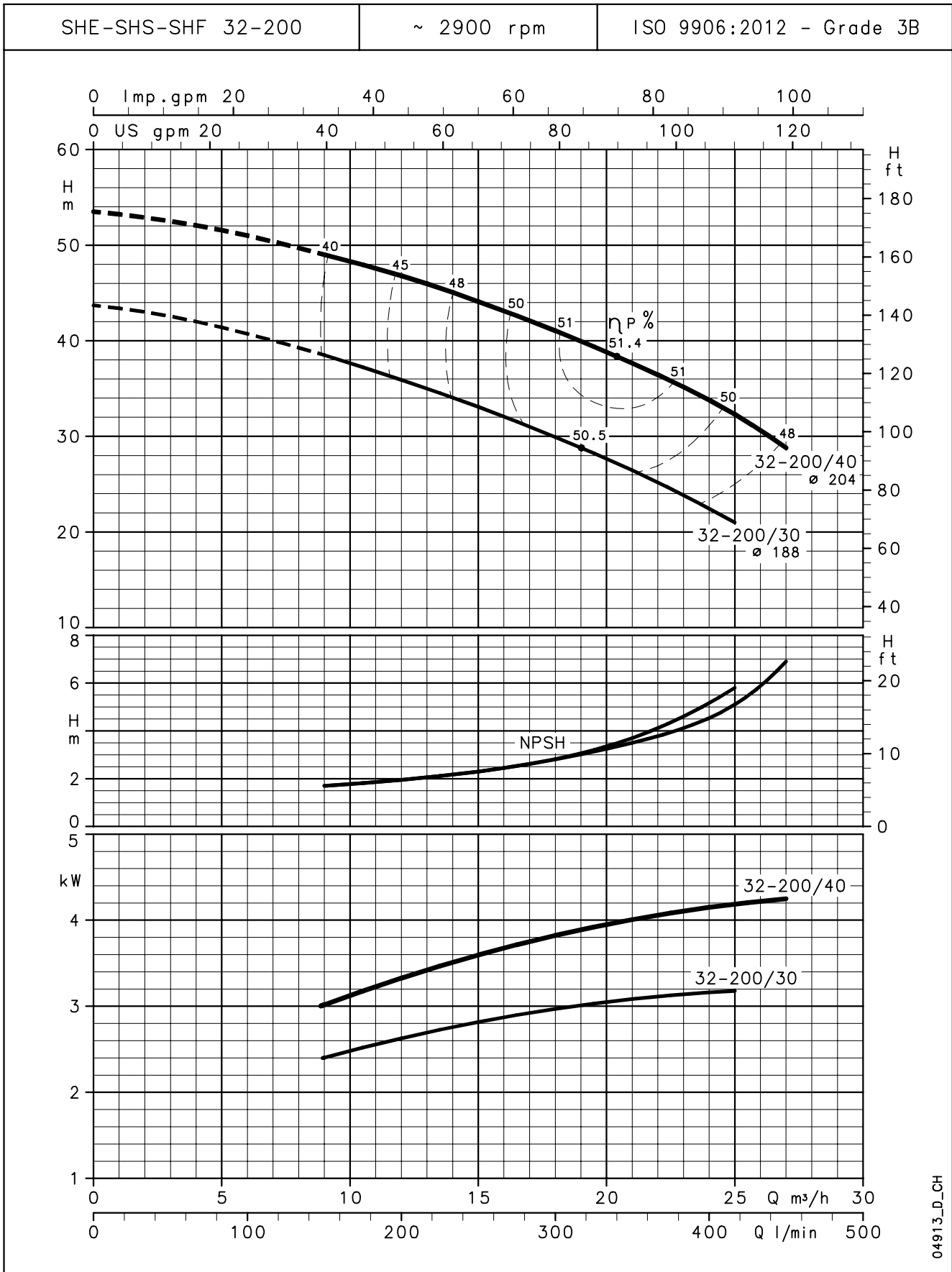

The NPSH values are laboratory values; for practical use we suggest increasing these values by 0,5 m.
 These performances are valid for liquids with density $\rho = 1,0 \text{ Kg/dm}^3$ and kinematic viscosity $\nu = 1 \text{ mm}^2/\text{sec}$.

**SHE-SHS-SHF SERIES
OPERATING CHARACTERISTICS AT 50 Hz, 2 POLES**

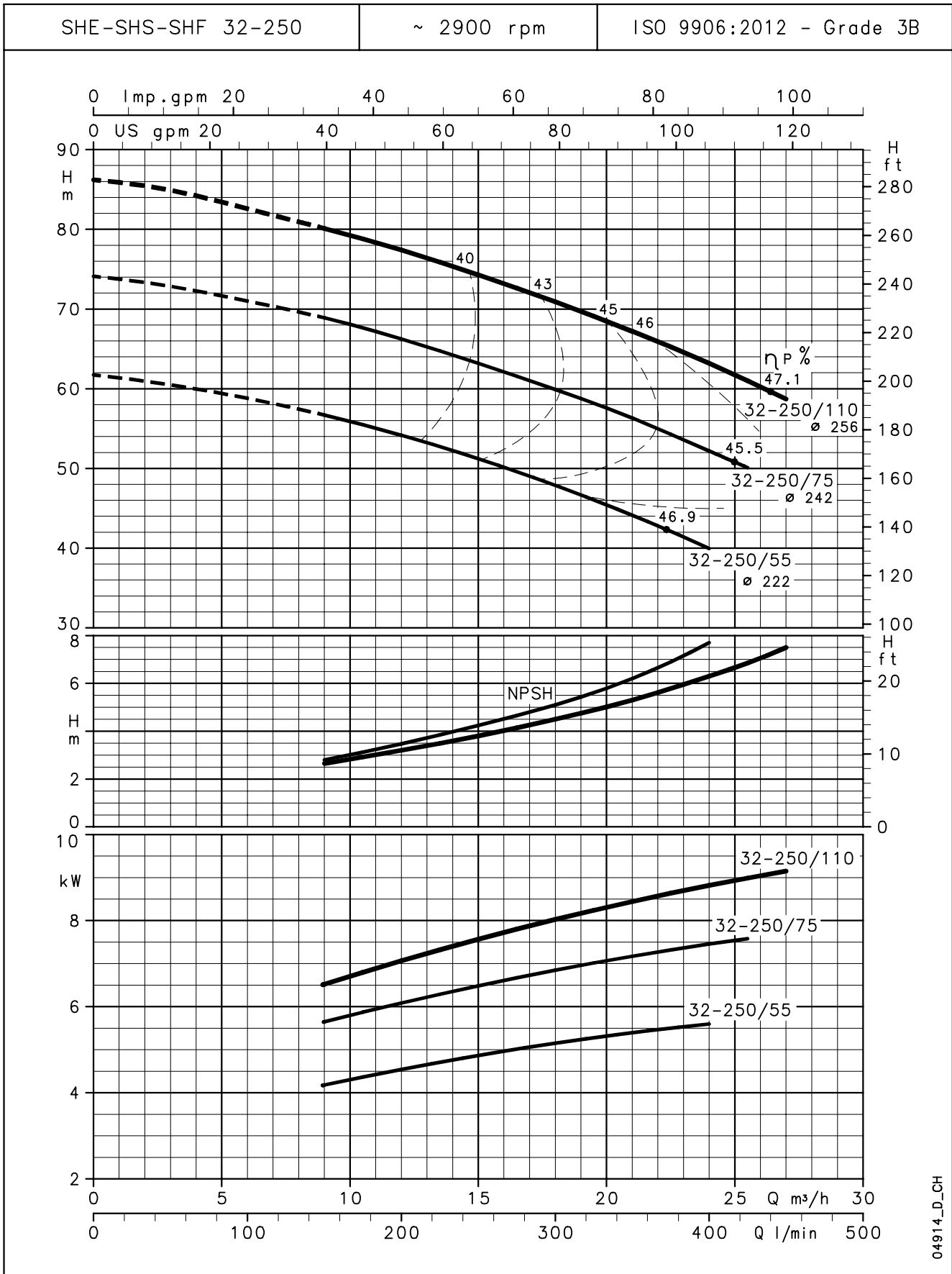

04914_D_CH

The NPSH values are laboratory values; for practical use we suggest increasing these values by 0,5 m.
These performances are valid for liquids with density ρ = 1,0 Kg/dm³ and kinematic viscosity ν = 1 mm²/sec.

SHE-SHS-SHF SERIES OPERATING CHARACTERISTICS AT 50 Hz, 2 POLES

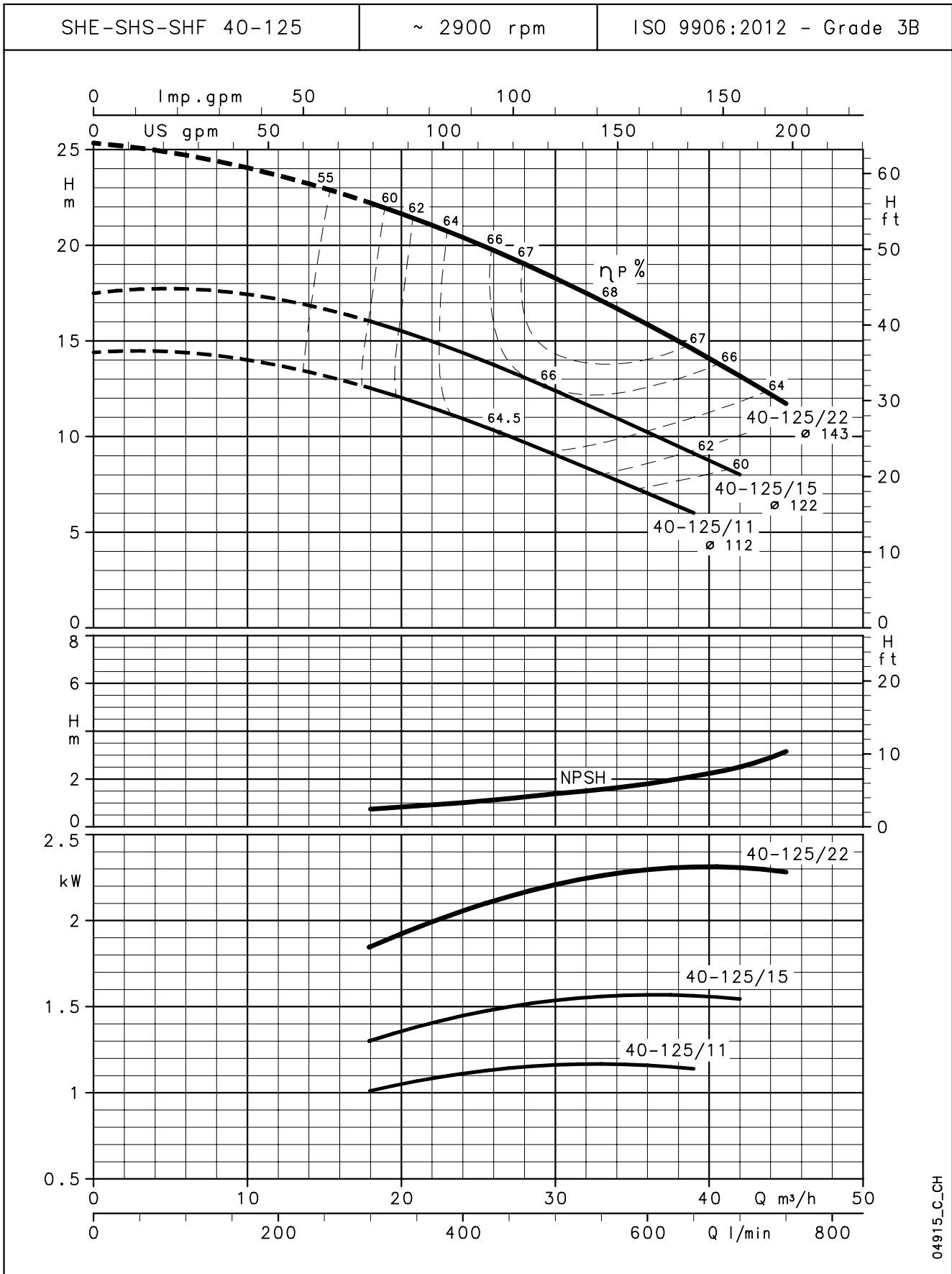

04915_C_CH

The NPSH values are laboratory values; for practical use we suggest increasing these values by 0,5 m.
 These performances are valid for liquids with density $\rho = 1,0 \text{ Kg/dm}^3$ and kinematic viscosity $\nu = 1 \text{ mm}^2/\text{sec}$.

**SHE-SHS-SHF SERIES
OPERATING CHARACTERISTICS AT 50 Hz, 2 POLES**

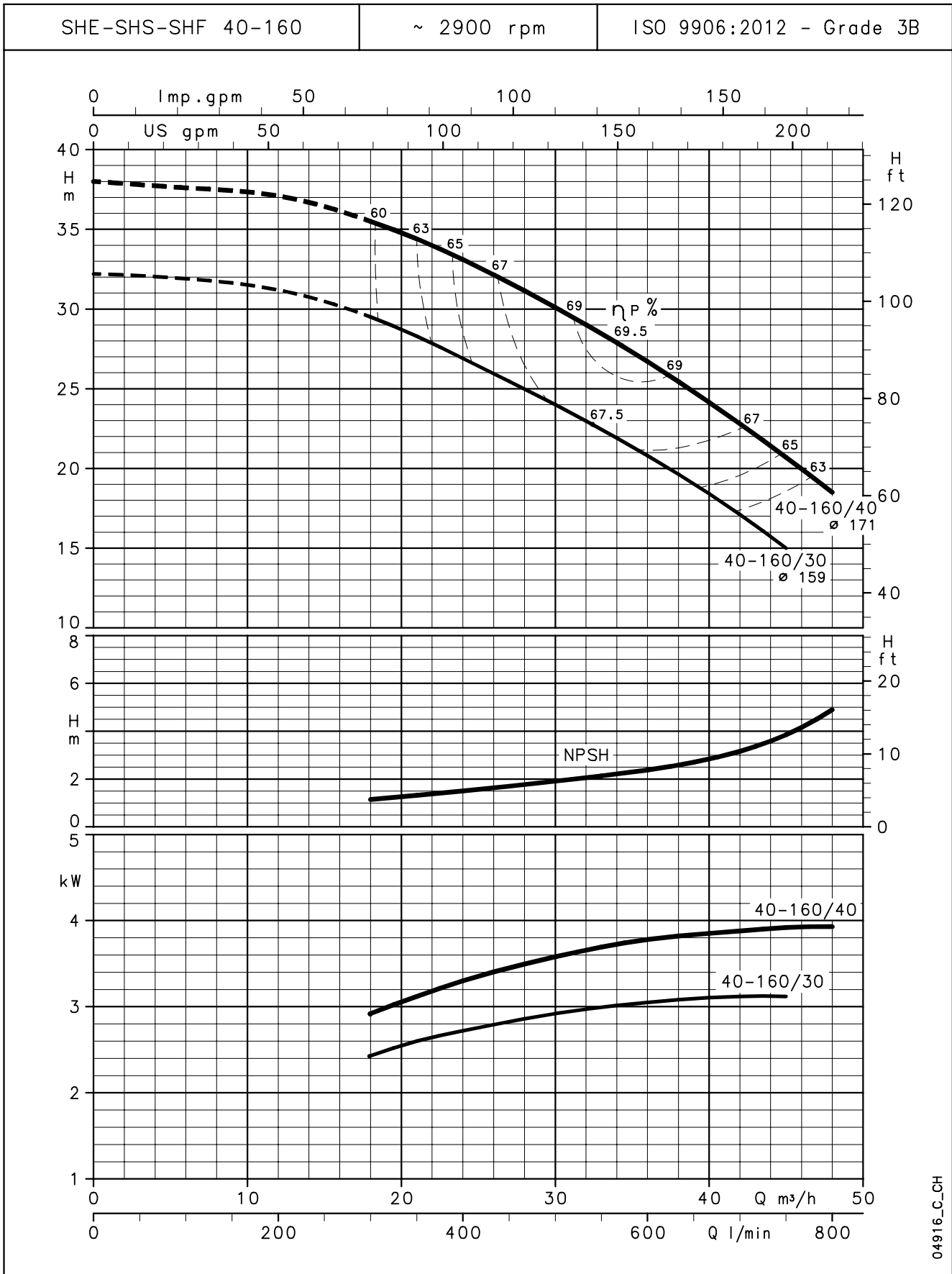

04916_C_CH

The NPSH values are laboratory values; for practical use we suggest increasing these values by 0,5 m.
These performances are valid for liquids with density $\rho = 1,0 \text{ Kg/dm}^3$ and kinematic viscosity $\nu = 1 \text{ mm}^2/\text{sec}$.

SHE-SHS-SHF SERIES
OPERATING CHARACTERISTICS AT 50 Hz, 2 POLES

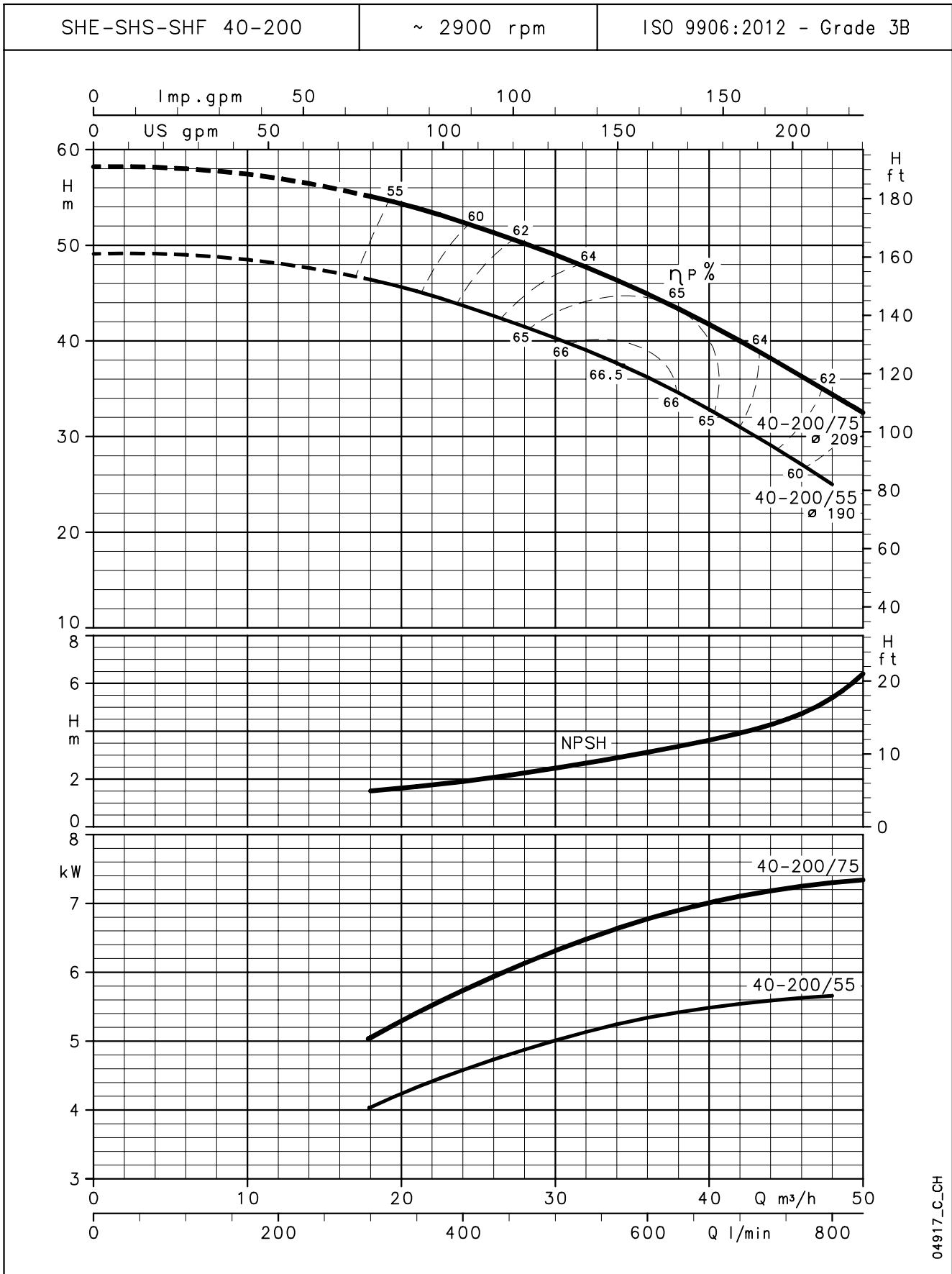

04917_C_CH

The NPSH values are laboratory values; for practical use we suggest increasing these values by 0,5 m.
These performances are valid for liquids with density $\rho = 1,0 \text{ Kg/dm}^3$ and kinematic viscosity $\nu = 1 \text{ mm}^2/\text{sec}$.

**SHE-SHS-SHF SERIES
OPERATING CHARACTERISTICS AT 50 Hz, 2 POLES**

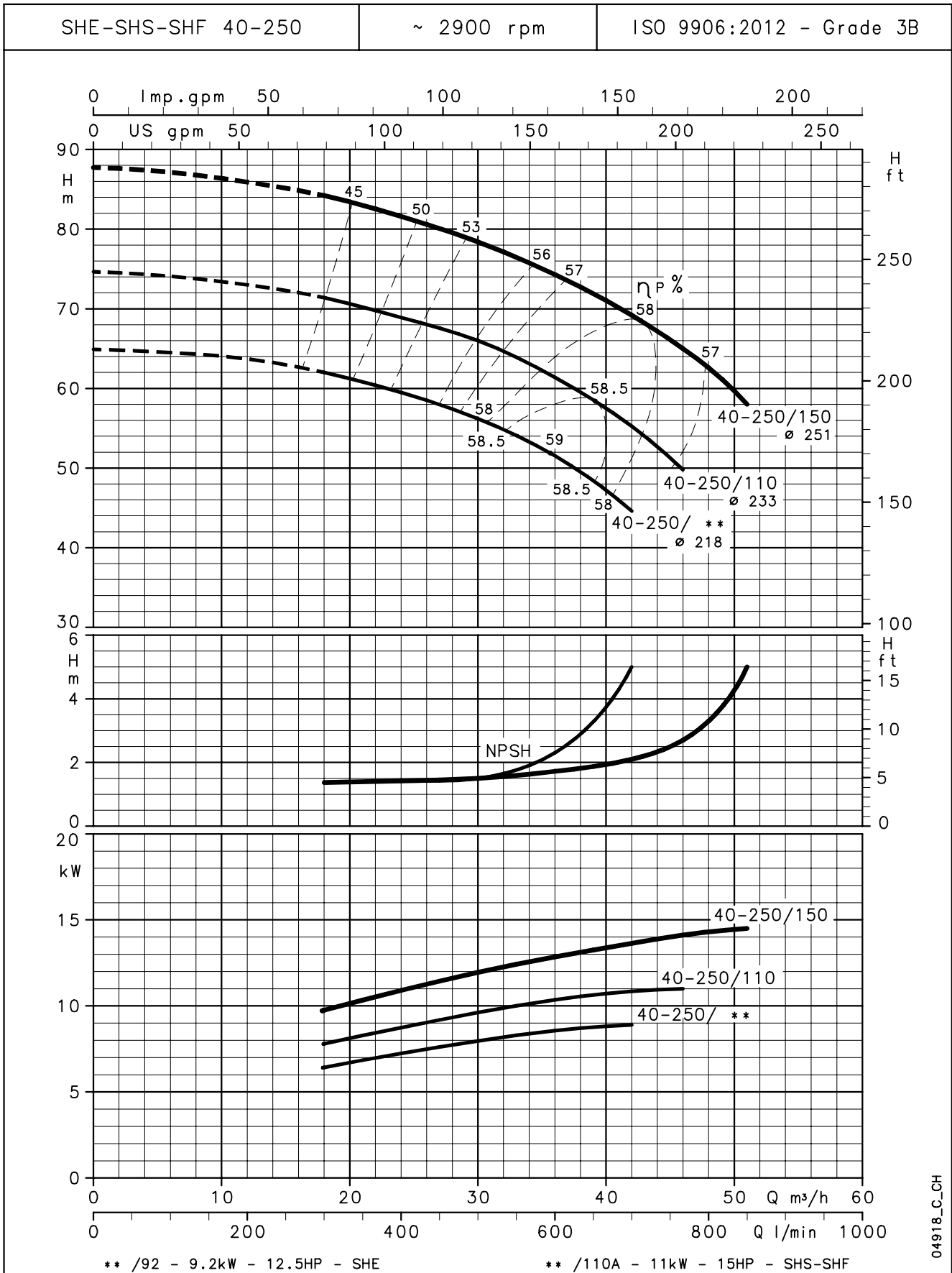

04918_C_CH

The NPSH values are laboratory values; for practical use we suggest increasing these values by 0,5 m.
 These performances are valid for liquids with density $\rho = 1,0 \text{ Kg/dm}^3$ and kinematic viscosity $\nu = 1 \text{ mm}^2/\text{sec}$.

**SHE-SHS-SHF SERIES
OPERATING CHARACTERISTICS AT 50 Hz, 2 POLES**

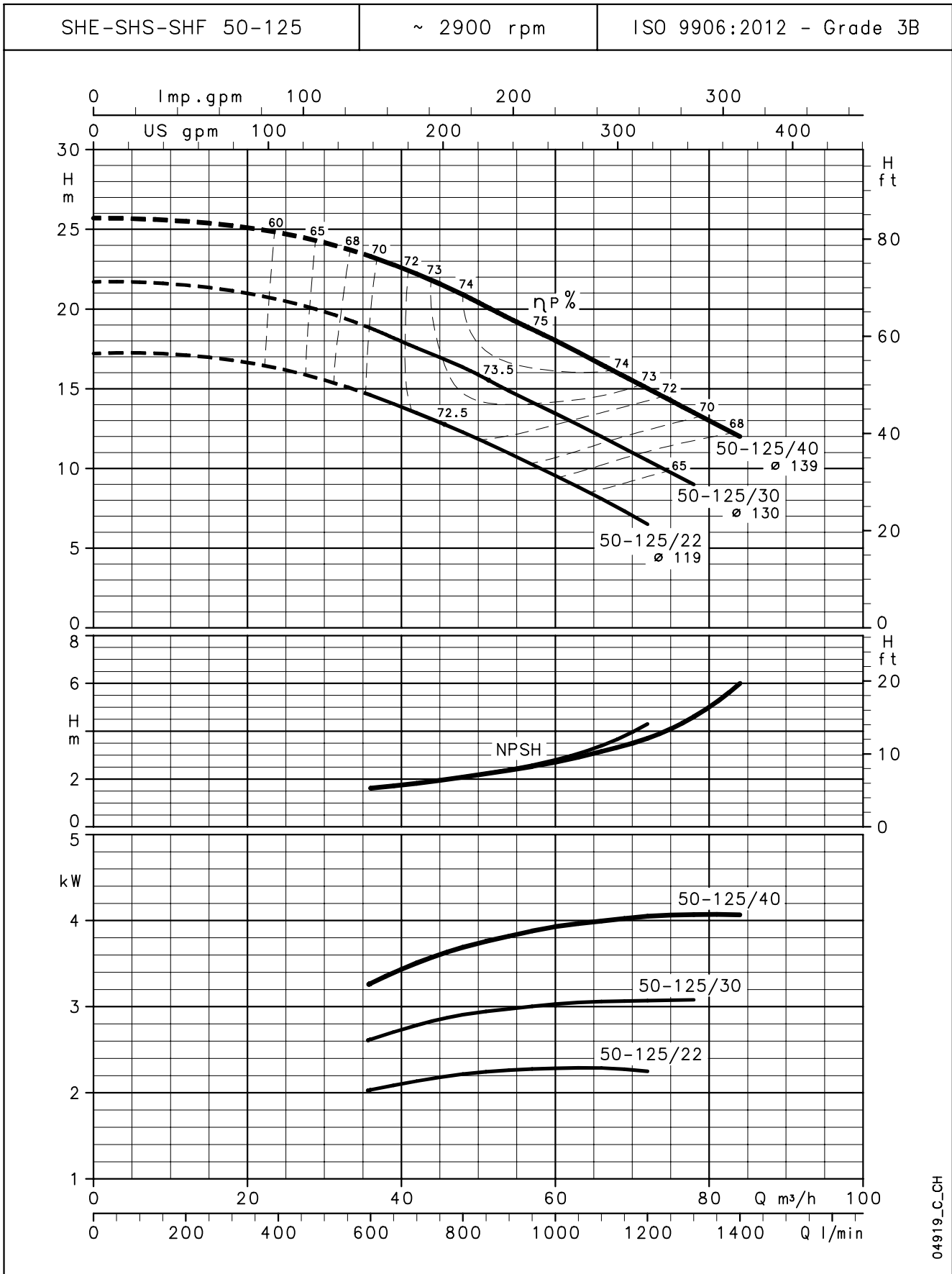

04919_C_CH

The NPSH values are laboratory values; for practical use we suggest increasing these values by 0,5 m.
These performances are valid for liquids with density $\rho = 1,0 \text{ Kg/dm}^3$ and kinematic viscosity $\nu = 1 \text{ mm}^2/\text{sec}$.

**SHE-SHS-SHF SERIES
OPERATING CHARACTERISTICS AT 50 Hz, 2 POLES**

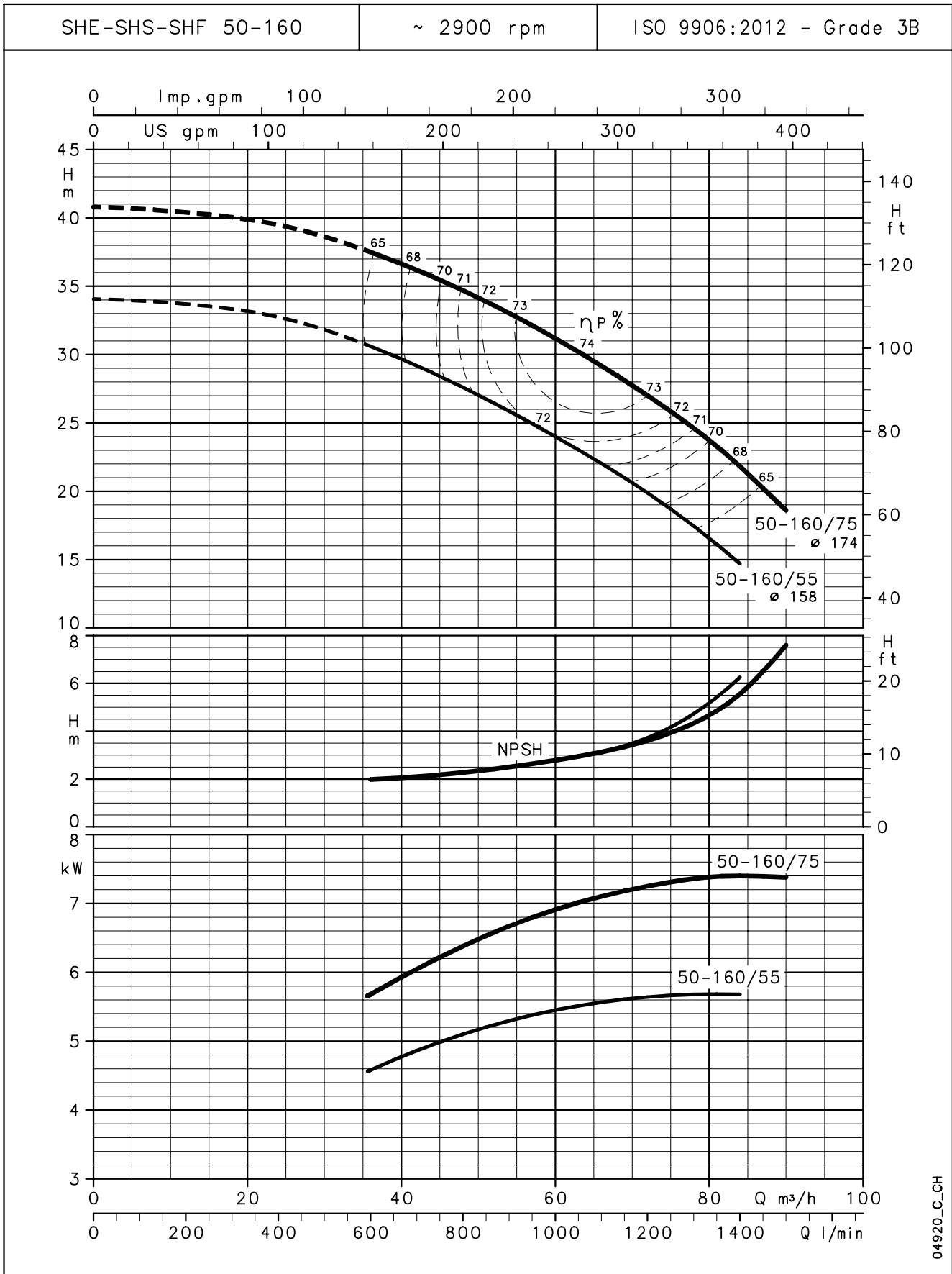

04920_C_CH

The NPSH values are laboratory values; for practical use we suggest increasing these values by 0,5 m.
These performances are valid for liquids with density $\rho = 1,0 \text{ Kg/dm}^3$ and kinematic viscosity $\nu = 1 \text{ mm}^2/\text{sec}$.

**SHE-SHS-SHF SERIES
OPERATING CHARACTERISTICS AT 50 Hz, 2 POLES**

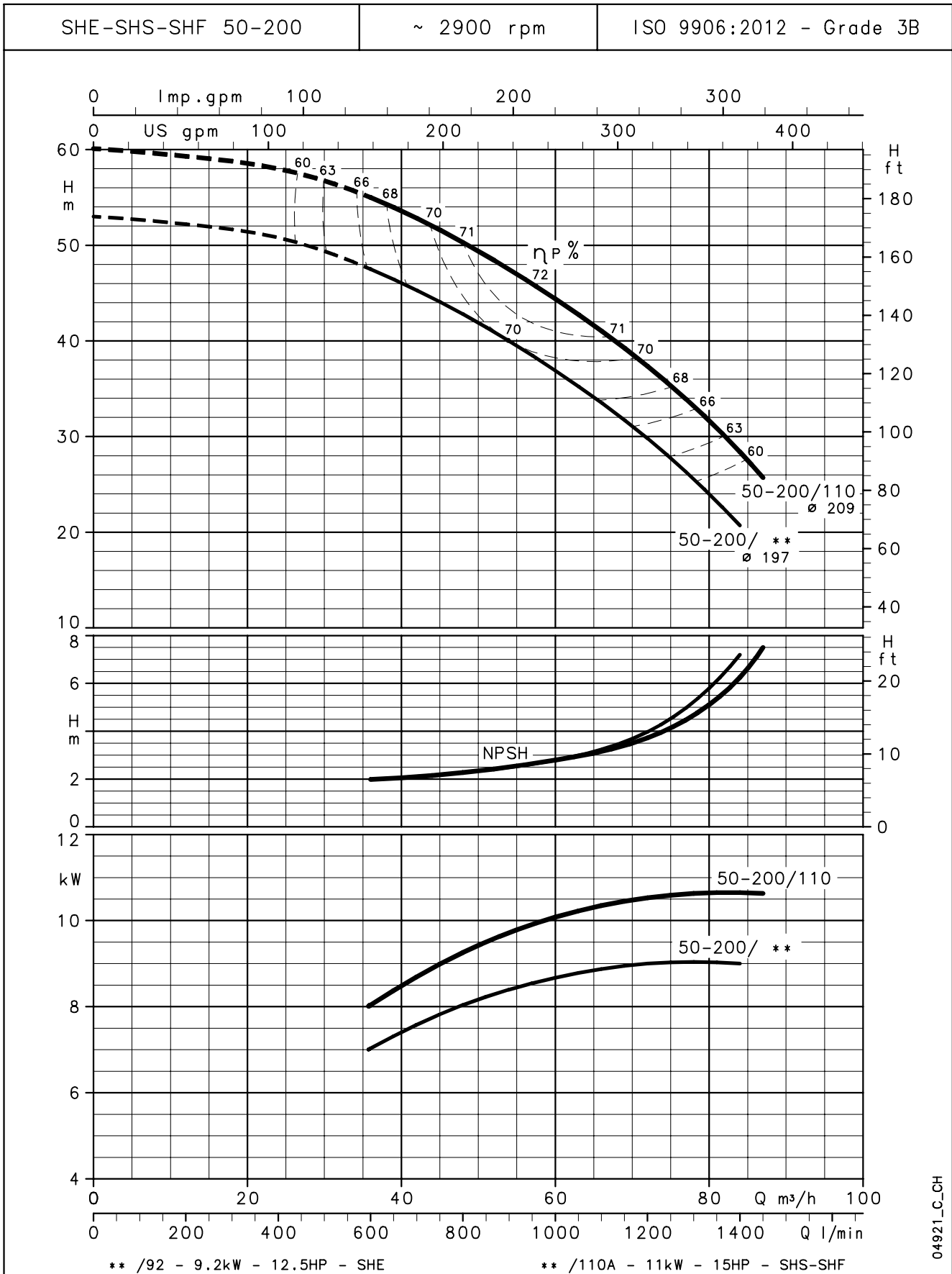

04921_C_CH

The NPSH values are laboratory values; for practical use we suggest increasing these values by 0,5 m.
These performances are valid for liquids with density $\rho = 1,0 \text{ Kg/dm}^3$ and kinematic viscosity $\nu = 1 \text{ mm}^2/\text{sec}$.

**SHE-SHS-SHF SERIES
OPERATING CHARACTERISTICS AT 50 Hz, 2 POLES**

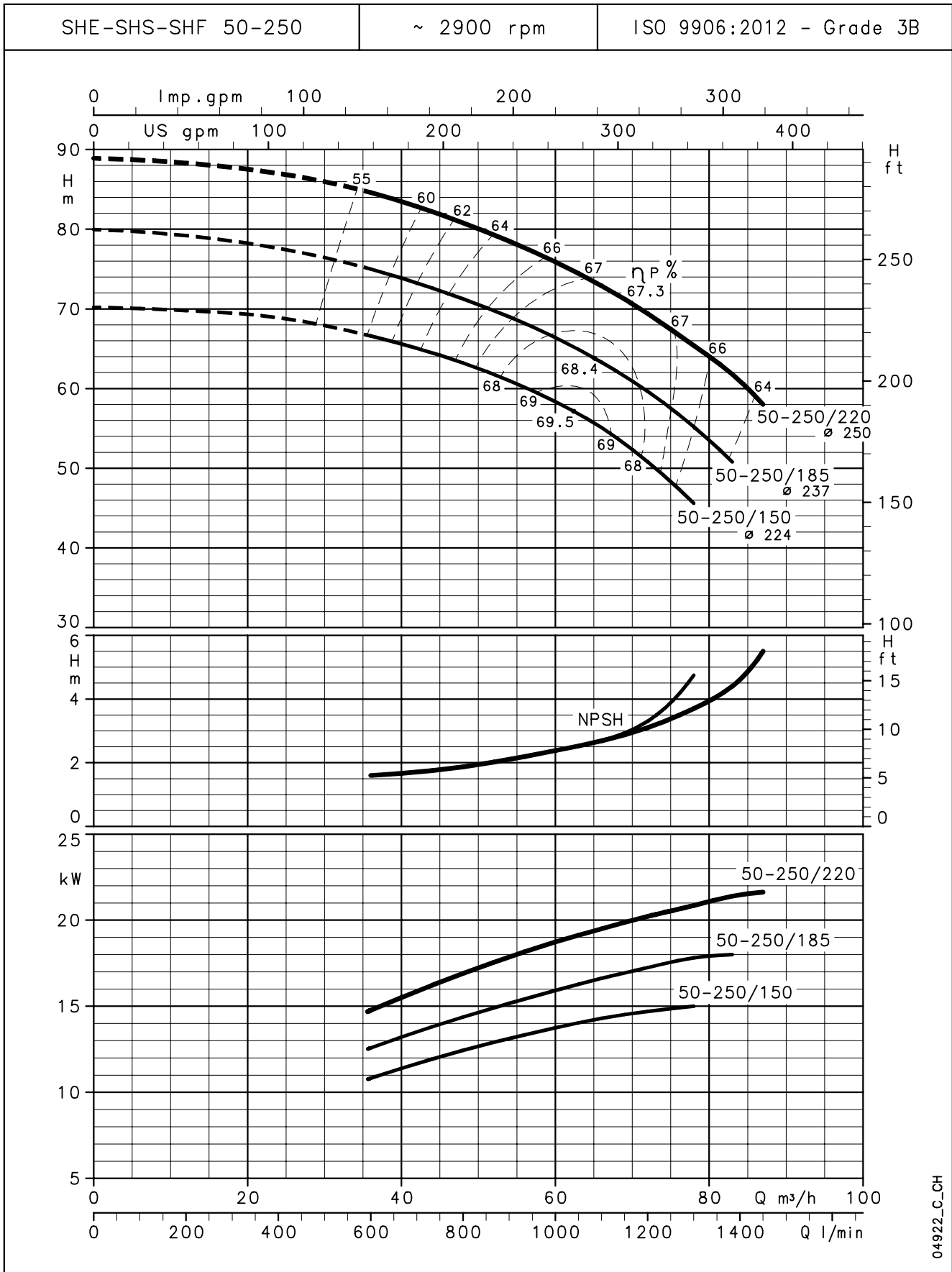

04922_C_CH

The NPSH values are laboratory values; for practical use we suggest increasing these values by 0,5 m.
These performances are valid for liquids with density $\rho = 1,0 \text{ Kg/dm}^3$ and kinematic viscosity $\nu = 1 \text{ mm}^2/\text{sec}$.

SHE-SHS-SHF SERIES
OPERATING CHARACTERISTICS AT 50 Hz, 2 POLES

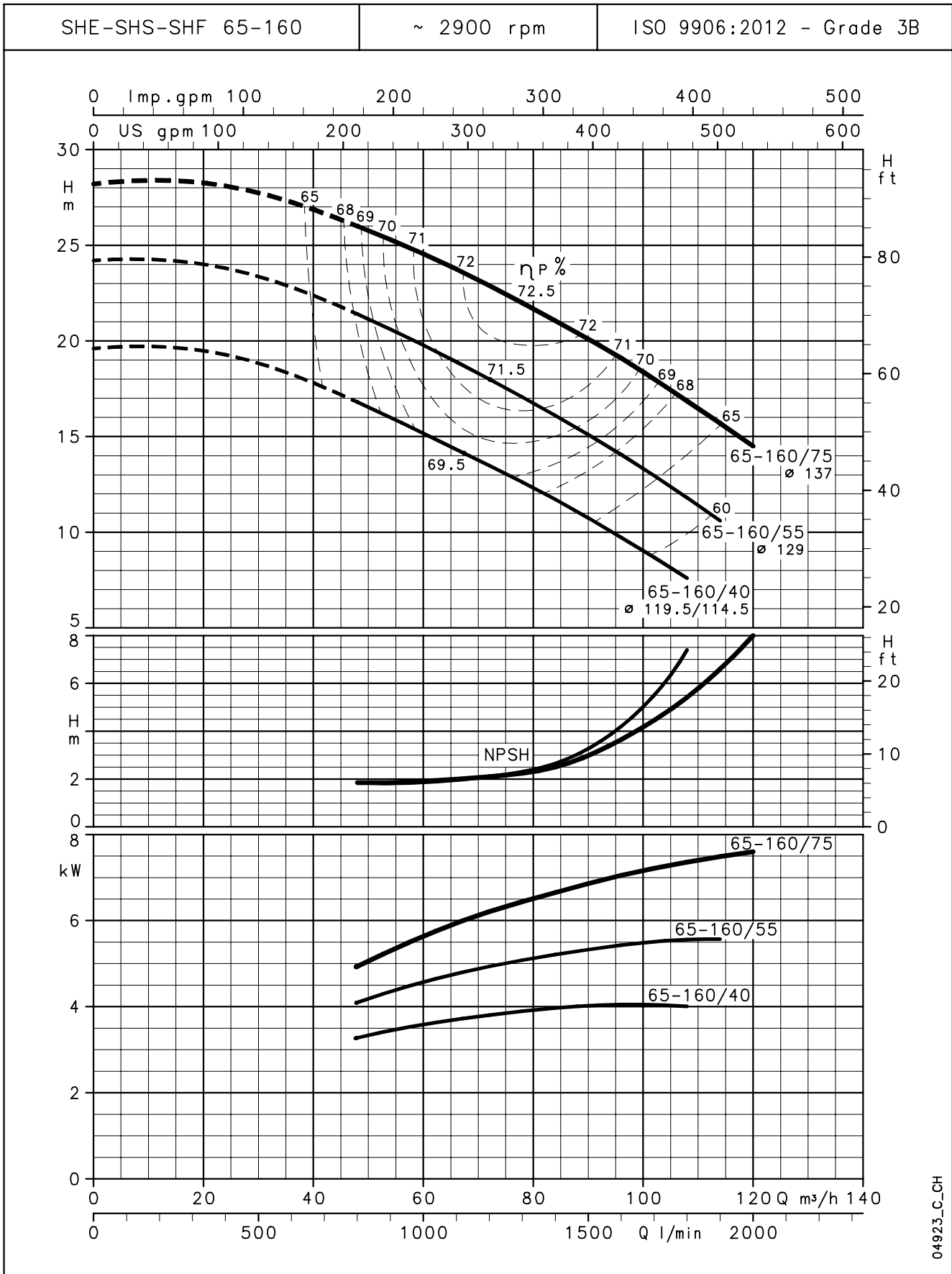

04923_C_CH

The NPSH values are laboratory values; for practical use we suggest increasing these values by 0,5 m.
 These performances are valid for liquids with density $\rho = 1,0 \text{ Kg/dm}^3$ and kinematic viscosity $\nu = 1 \text{ mm}^2/\text{sec}$.

**SHE-SHS-SHF SERIES
OPERATING CHARACTERISTICS AT 50 Hz, 2 POLES**

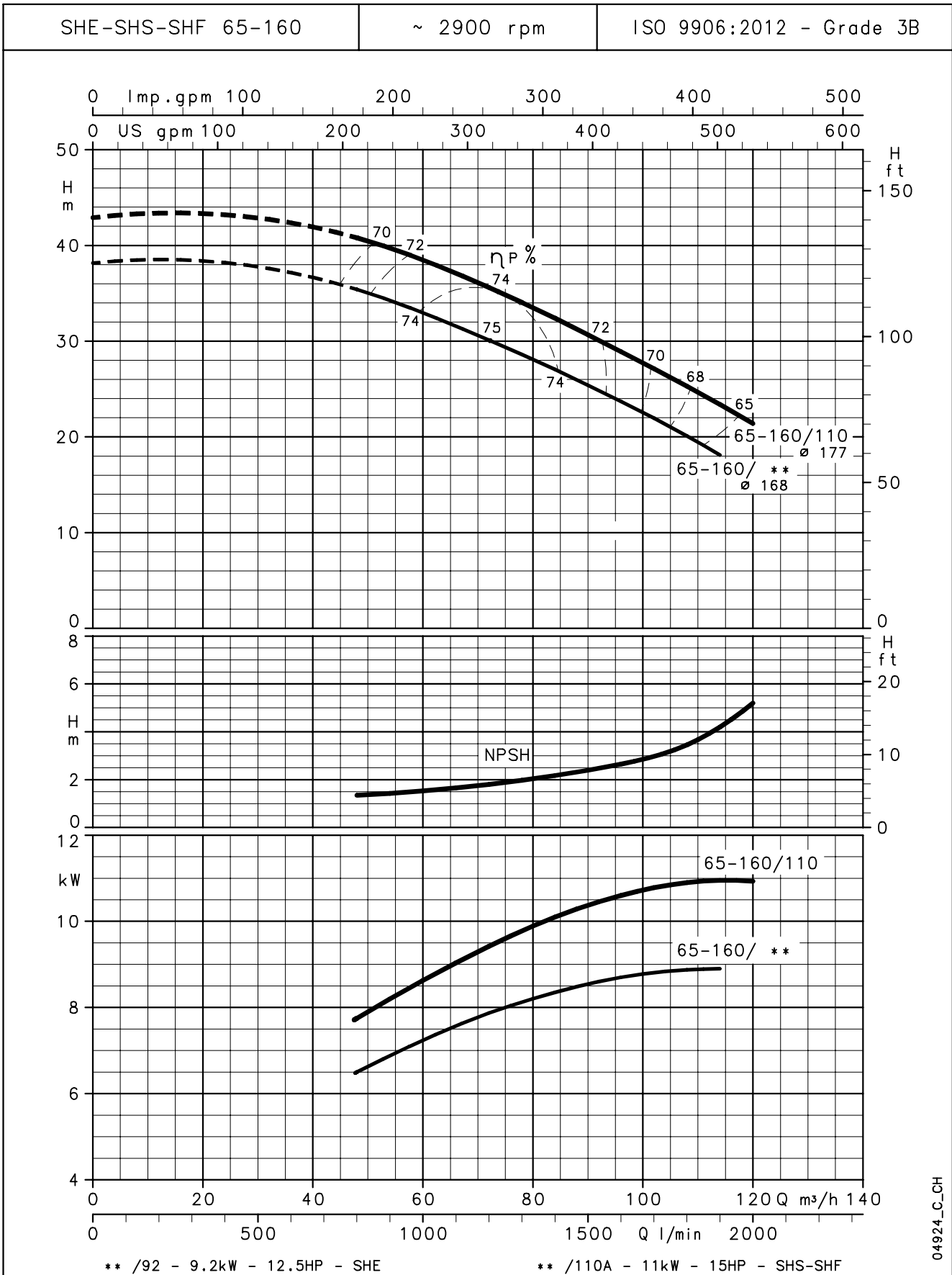

04924_C_CH

The NPSH values are laboratory values; for practical use we suggest increasing these values by 0,5 m.
These performances are valid for liquids with density $\rho = 1,0 \text{ Kg/dm}^3$ and kinematic viscosity $\nu = 1 \text{ mm}^2/\text{sec}$.

**SHE-SHS-SHF SERIES
OPERATING CHARACTERISTICS AT 50 Hz, 2 POLES**

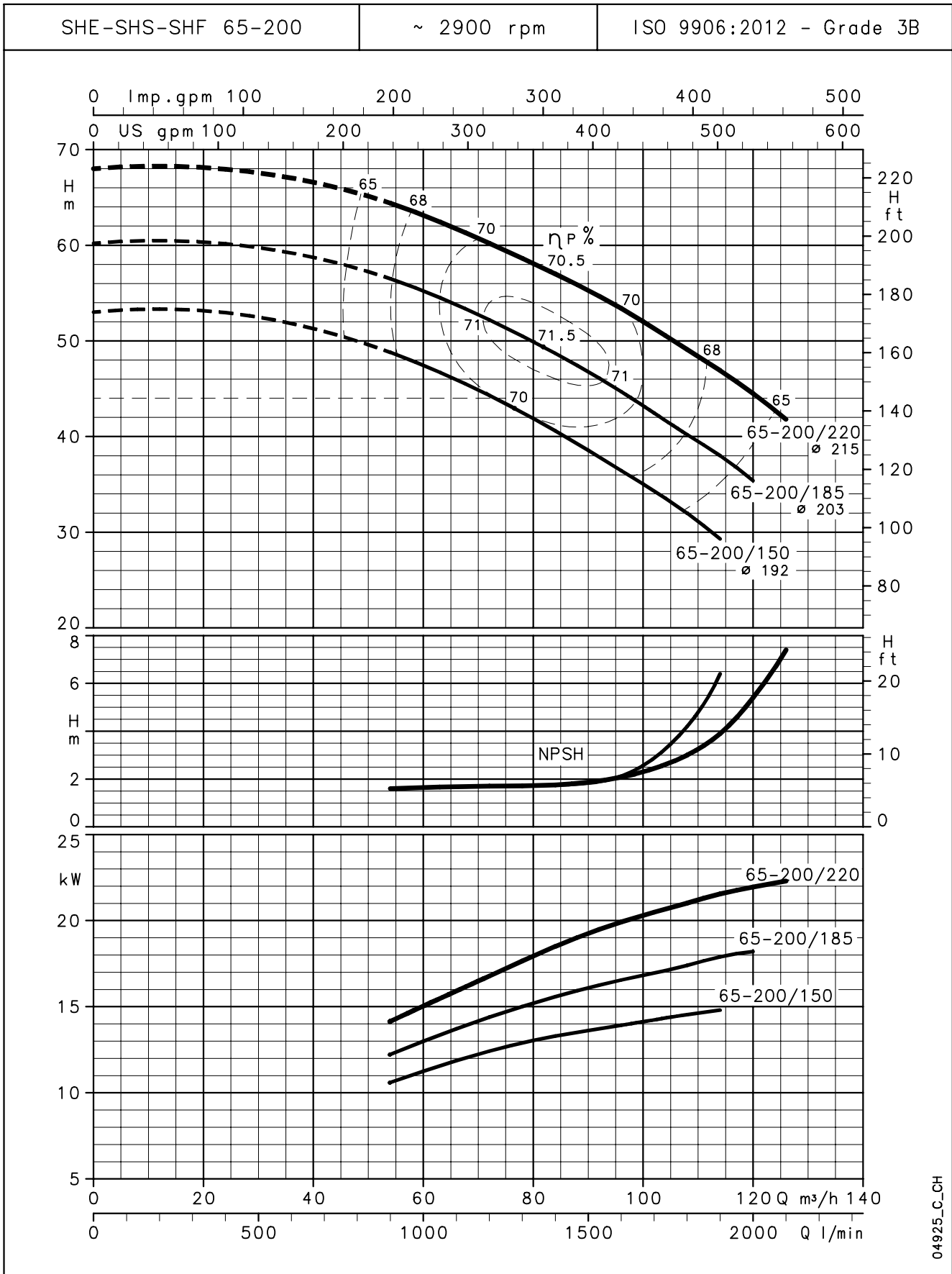

04925_C_CH

The NPSH values are laboratory values; for practical use we suggest increasing these values by 0,5 m.
These performances are valid for liquids with density $\rho = 1,0 \text{ Kg/dm}^3$ and kinematic viscosity $\nu = 1 \text{ mm}^2/\text{sec}$.

**SHS-SHF SERIES
OPERATING CHARACTERISTICS AT 50 Hz, 2 POLES**

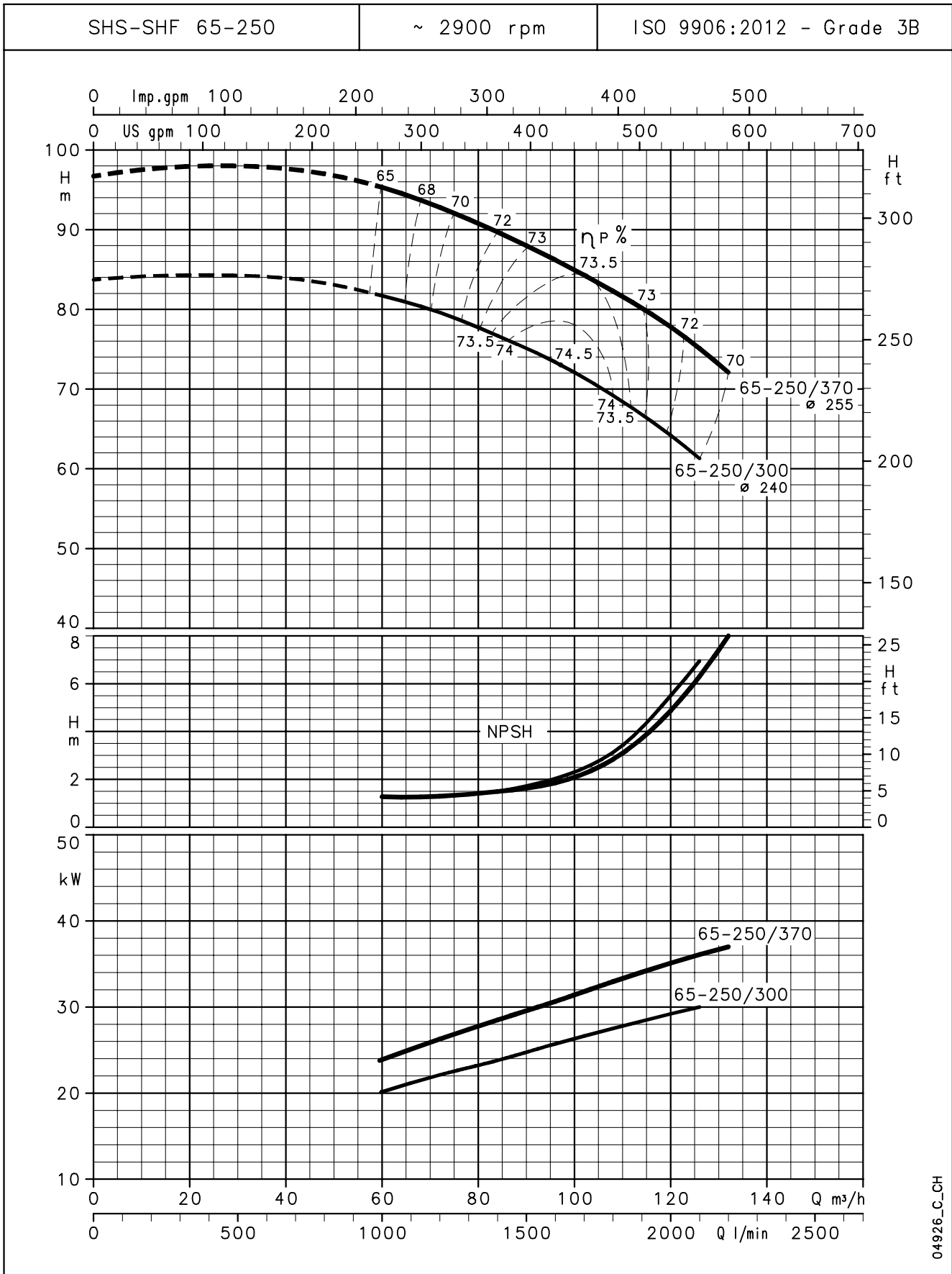

04926_C_CH

The NPSH values are laboratory values; for practical use we suggest increasing these values by 0,5 m.
These performances are valid for liquids with density $\rho = 1,0 \text{ Kg/dm}^3$ and kinematic viscosity $\nu = 1 \text{ mm}^2/\text{sec}$.

SHE-SHS-SHF SERIES
OPERATING CHARACTERISTICS AT 50 Hz, 2 POLES

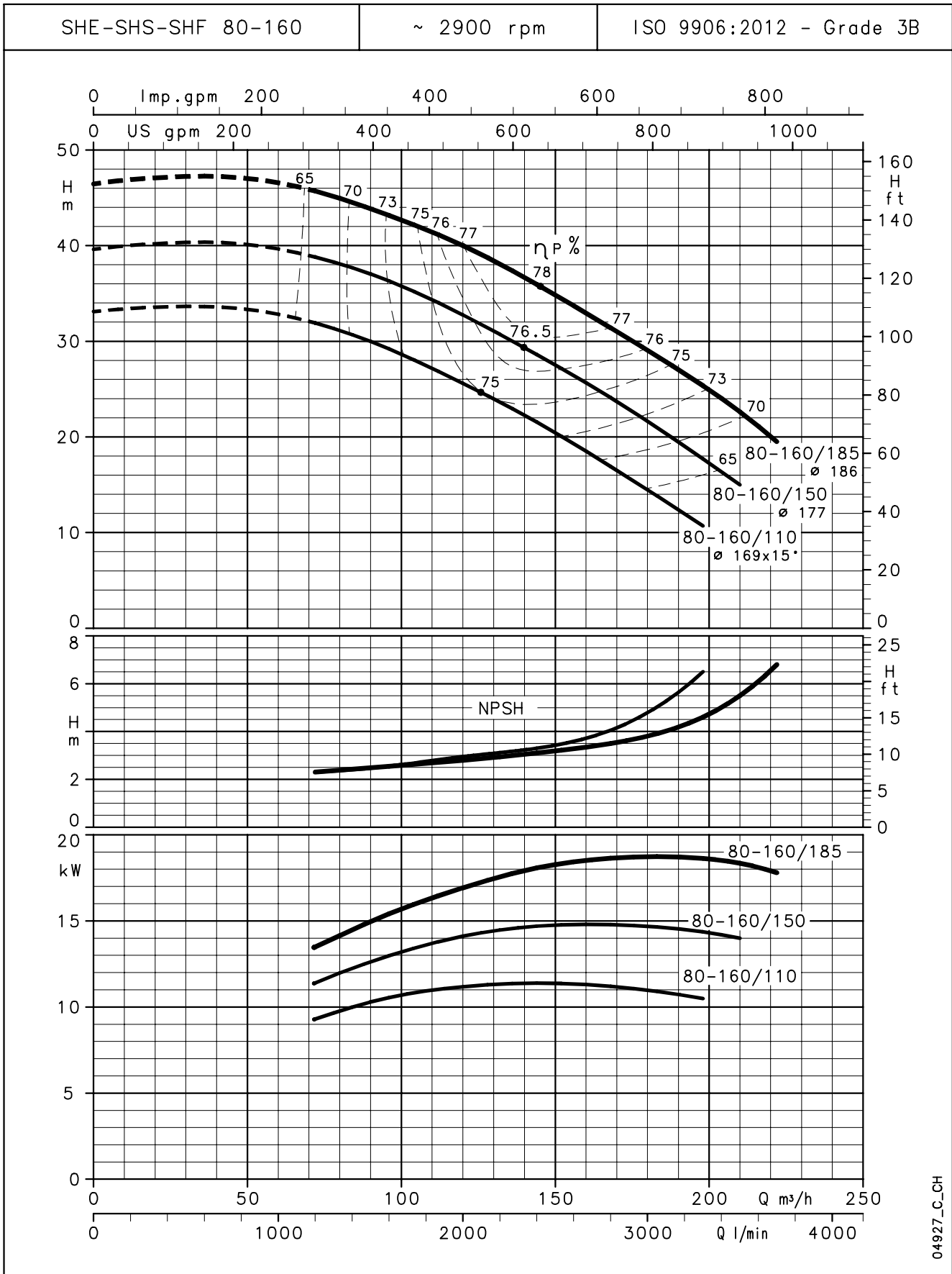

04927_C_CH

The NPSH values are laboratory values; for practical use we suggest increasing these values by 0,5 m.
These performances are valid for liquids with density $\rho = 1,0 \text{ Kg/dm}^3$ and kinematic viscosity $\nu = 1 \text{ mm}^2/\text{sec}$.

SHE-SHS-SHF SERIES OPERATING CHARACTERISTICS AT 50 Hz, 2 POLES

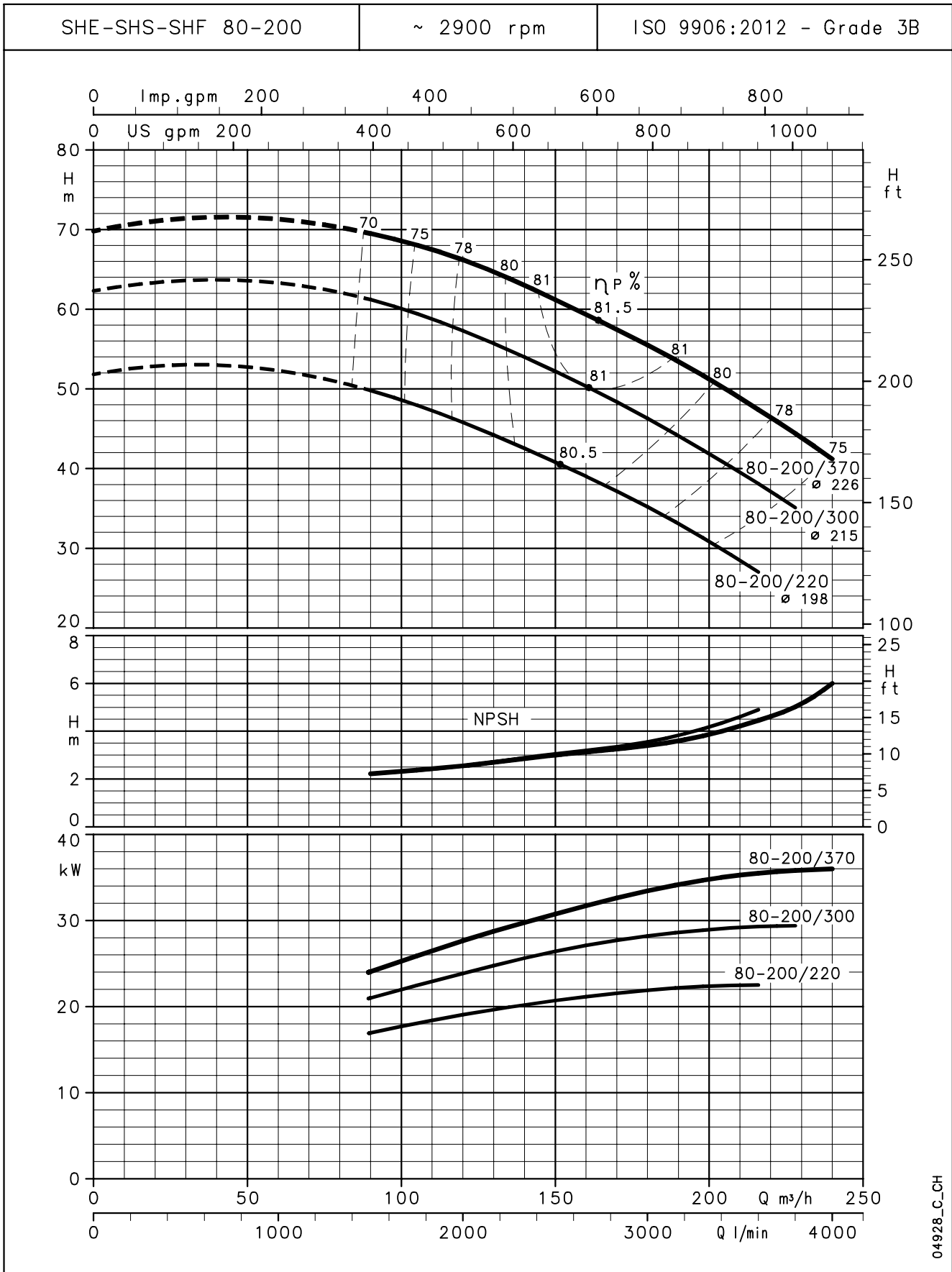

04928_C_CH

The NPSH values are laboratory values; for practical use we suggest increasing these values by 0,5 m.
 These performances are valid for liquids with density $\rho = 1,0 \text{ Kg/dm}^3$ and kinematic viscosity $\nu = 1 \text{ mm}^2/\text{sec}$.

**SHF SERIES
OPERATING CHARACTERISTICS AT 50 Hz, 2 POLES**

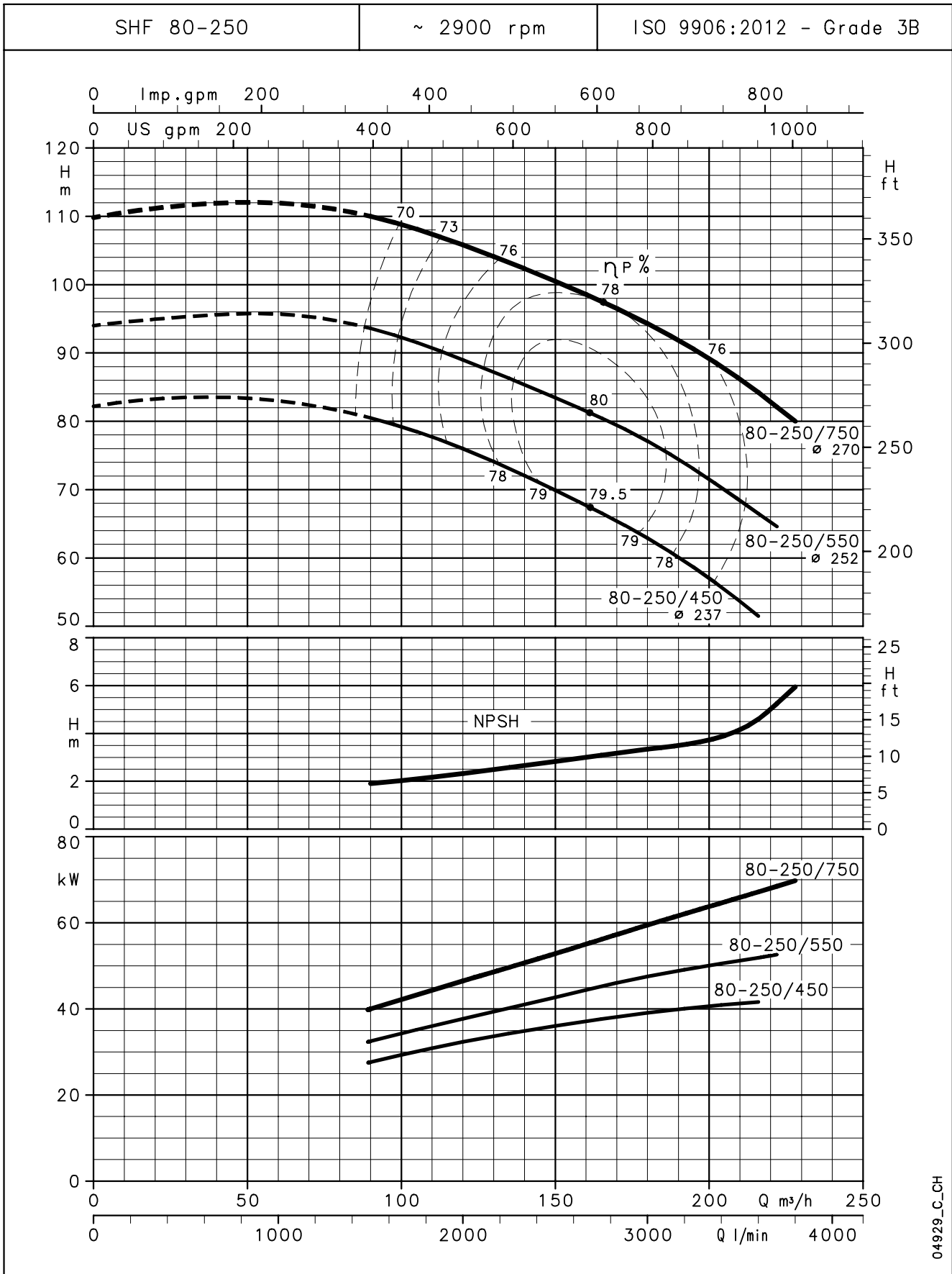

04929_C_CH

The NPSH values are laboratory values; for practical use we suggest increasing these values by 0,5 m.
These performances are valid for liquids with density $\rho = 1,0 \text{ Kg/dm}^3$ and kinematic viscosity $\nu = 1 \text{ mm}^2/\text{sec}$.

SHE4-SHF4 SERIES
OPERATING CHARACTERISTICS AT 50 Hz, 4 POLES

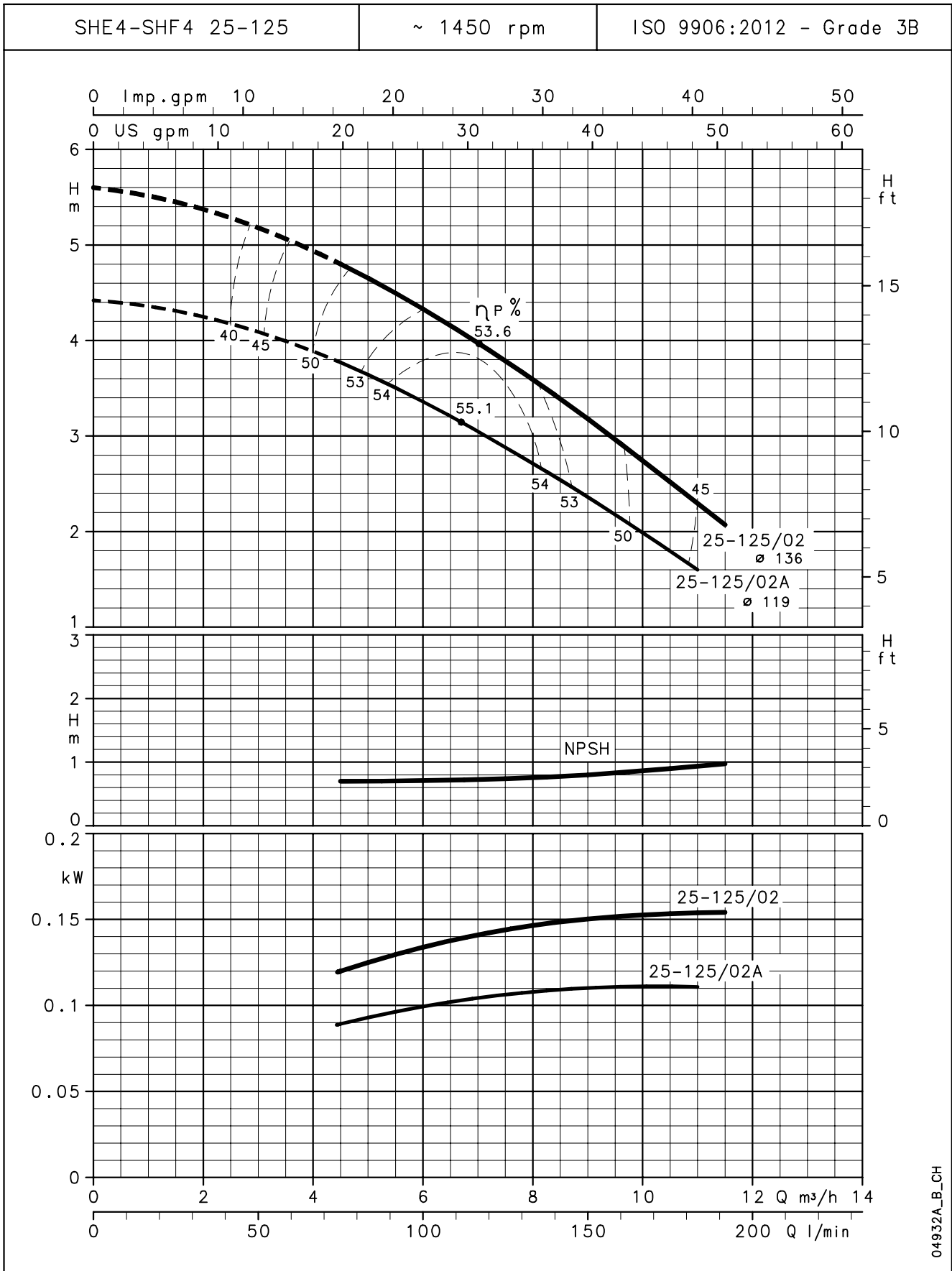

04932A_B_CH

The NPSH values are laboratory values; for practical use we suggest increasing these values by 0,5 m.
These performances are valid for liquids with density $\rho = 1,0 \text{ Kg/dm}^3$ and kinematic viscosity $\nu = 1 \text{ mm}^2/\text{sec}$.

**SHE4-SHF4 SERIES
OPERATING CHARACTERISTICS AT 50 Hz, 4 POLES**

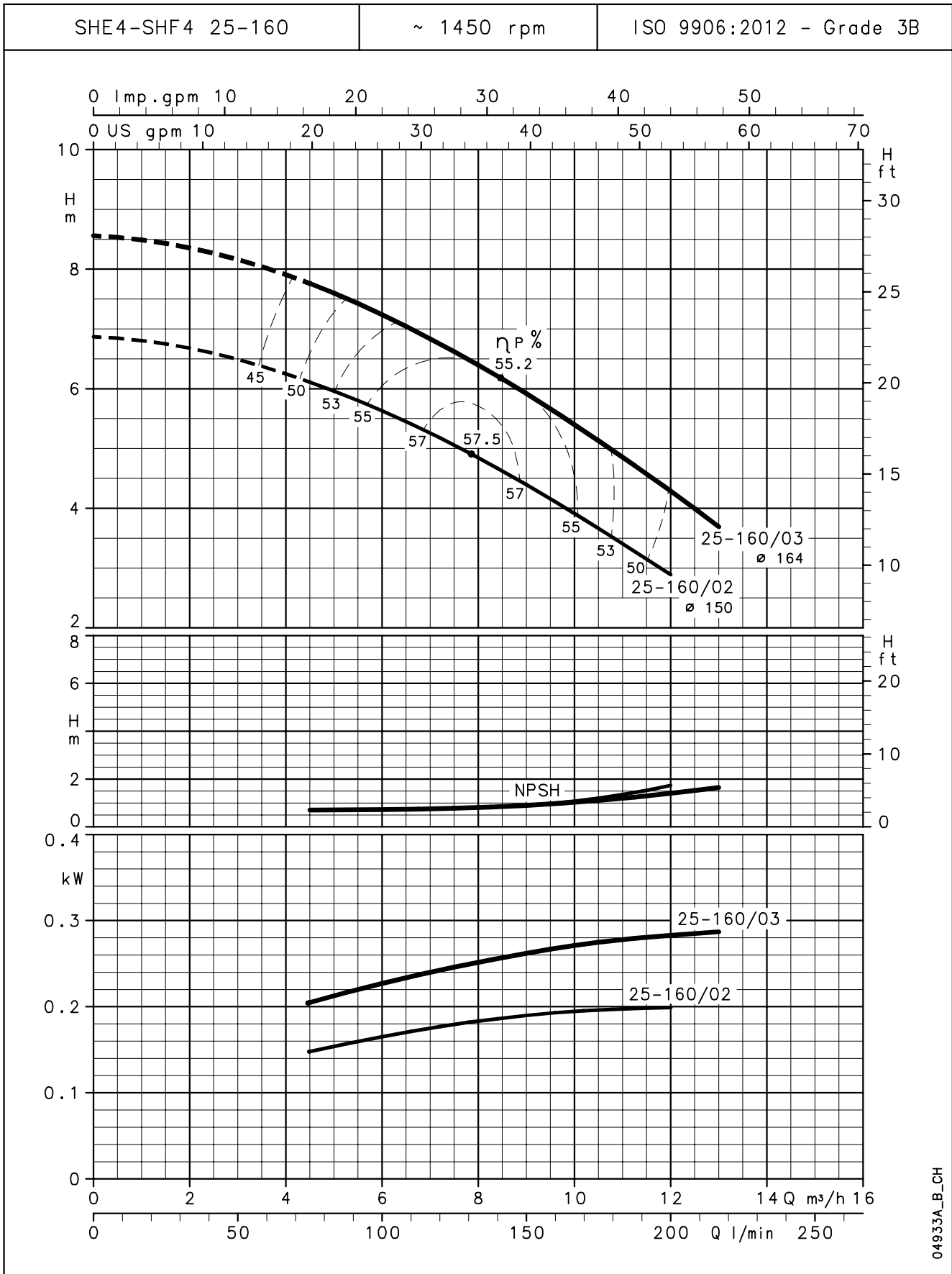

04933A_B_CH

The NPSH values are laboratory values; for practical use we suggest increasing these values by 0,5 m.
These performances are valid for liquids with density $\rho = 1,0 \text{ Kg/dm}^3$ and kinematic viscosity $\nu = 1 \text{ mm}^2/\text{sec}$.

SHE4-SHF4 SERIES
OPERATING CHARACTERISTICS AT 50 Hz, 4 POLES

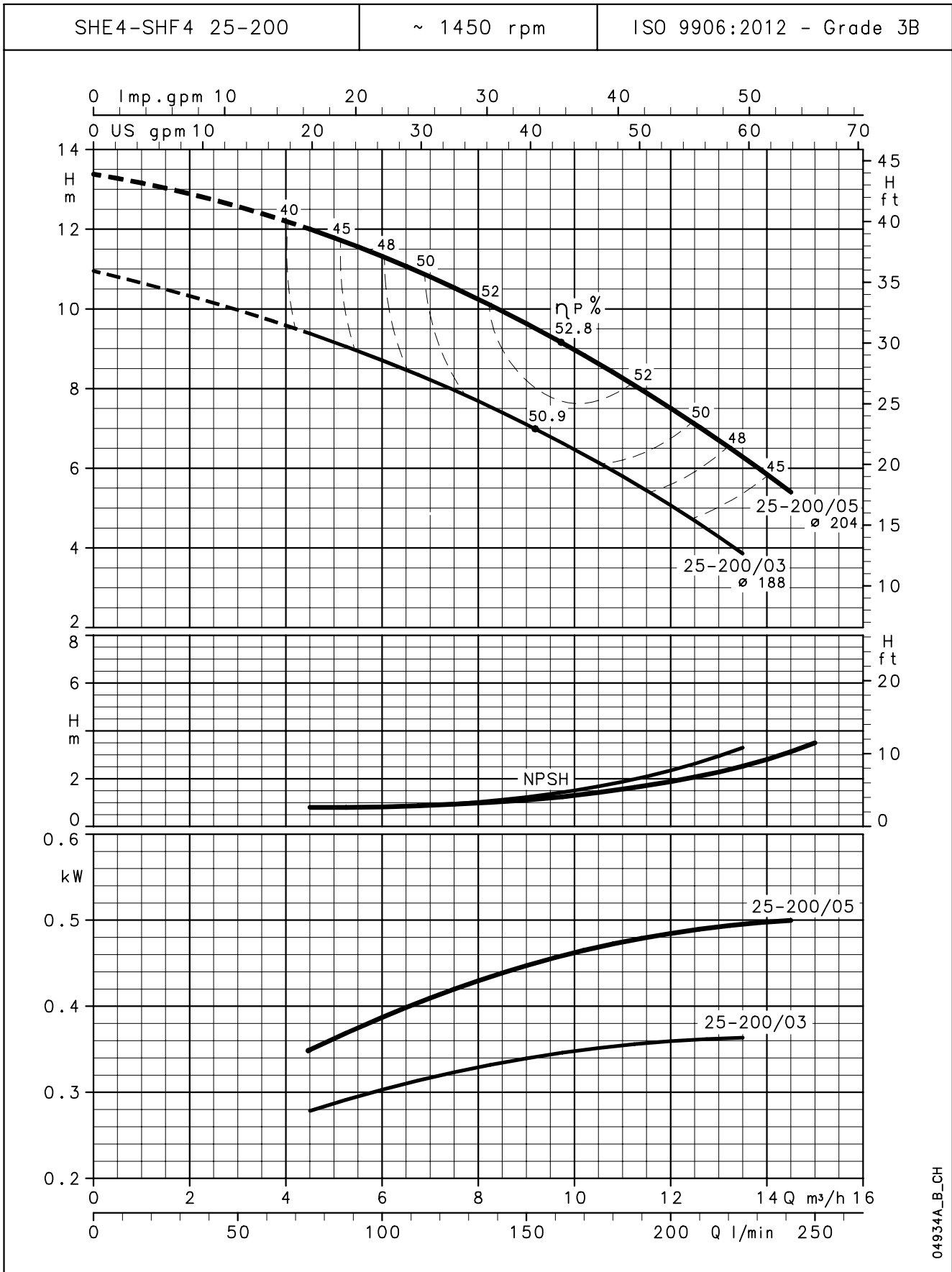

04934A_B_CH

The NPSH values are laboratory values; for practical use we suggest increasing these values by 0,5 m.
 These performances are valid for liquids with density $\rho = 1,0 \text{ Kg/dm}^3$ and kinematic viscosity $\nu = 1 \text{ mm}^2/\text{sec}$.

**SHE4-SHS4-SHF4 SERIES
OPERATING CHARACTERISTICS AT 50 Hz, 4 POLES**

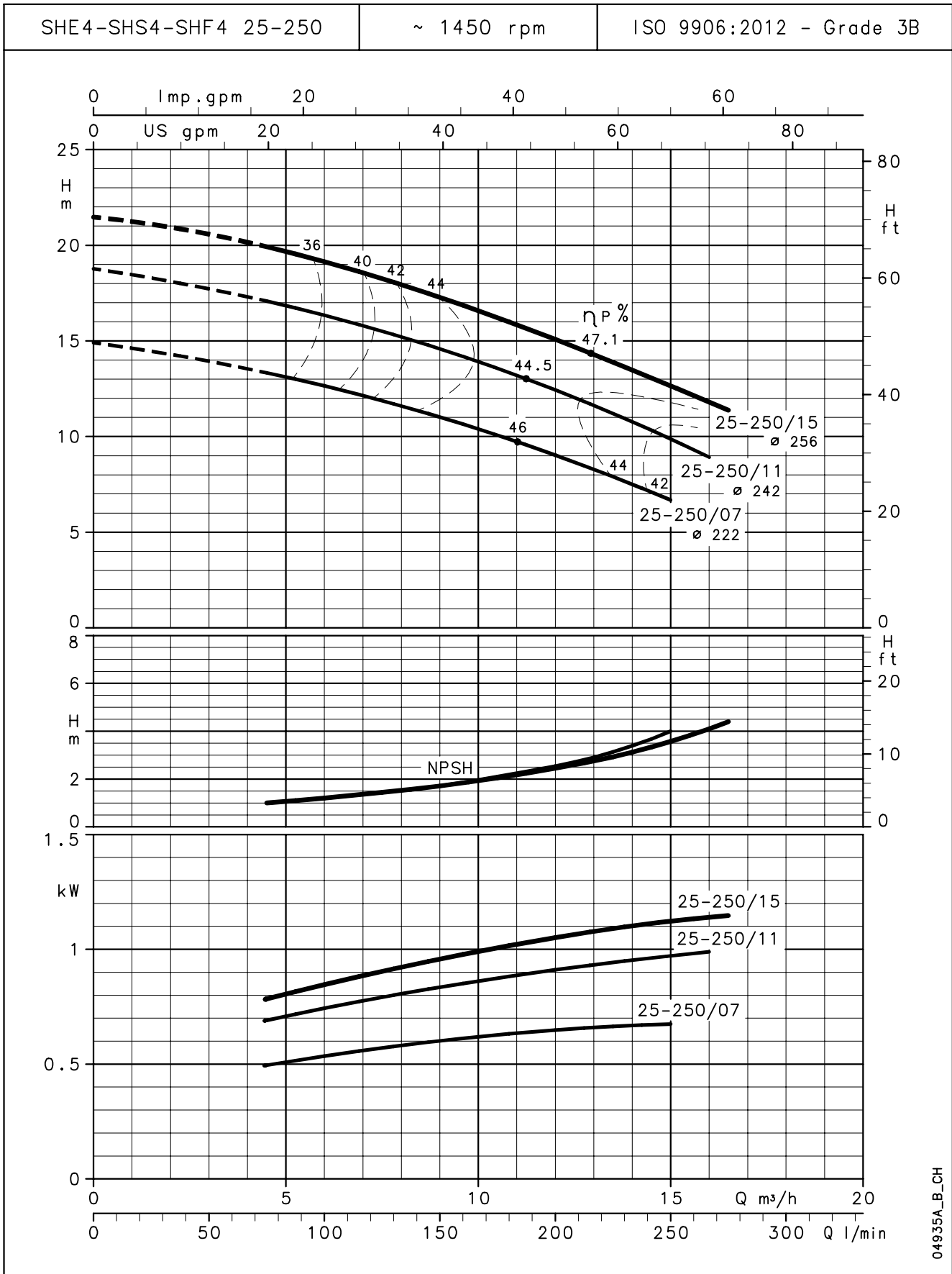

04935A_B_CH

The NPSH values are laboratory values; for practical use we suggest increasing these values by 0,5 m.
These performances are valid for liquids with density $\rho = 1,0 \text{ Kg/dm}^3$ and kinematic viscosity $\nu = 1 \text{ mm}^2/\text{sec}$.

**SHE4-SHF4 SERIES
OPERATING CHARACTERISTICS AT 50 Hz, 4 POLES**

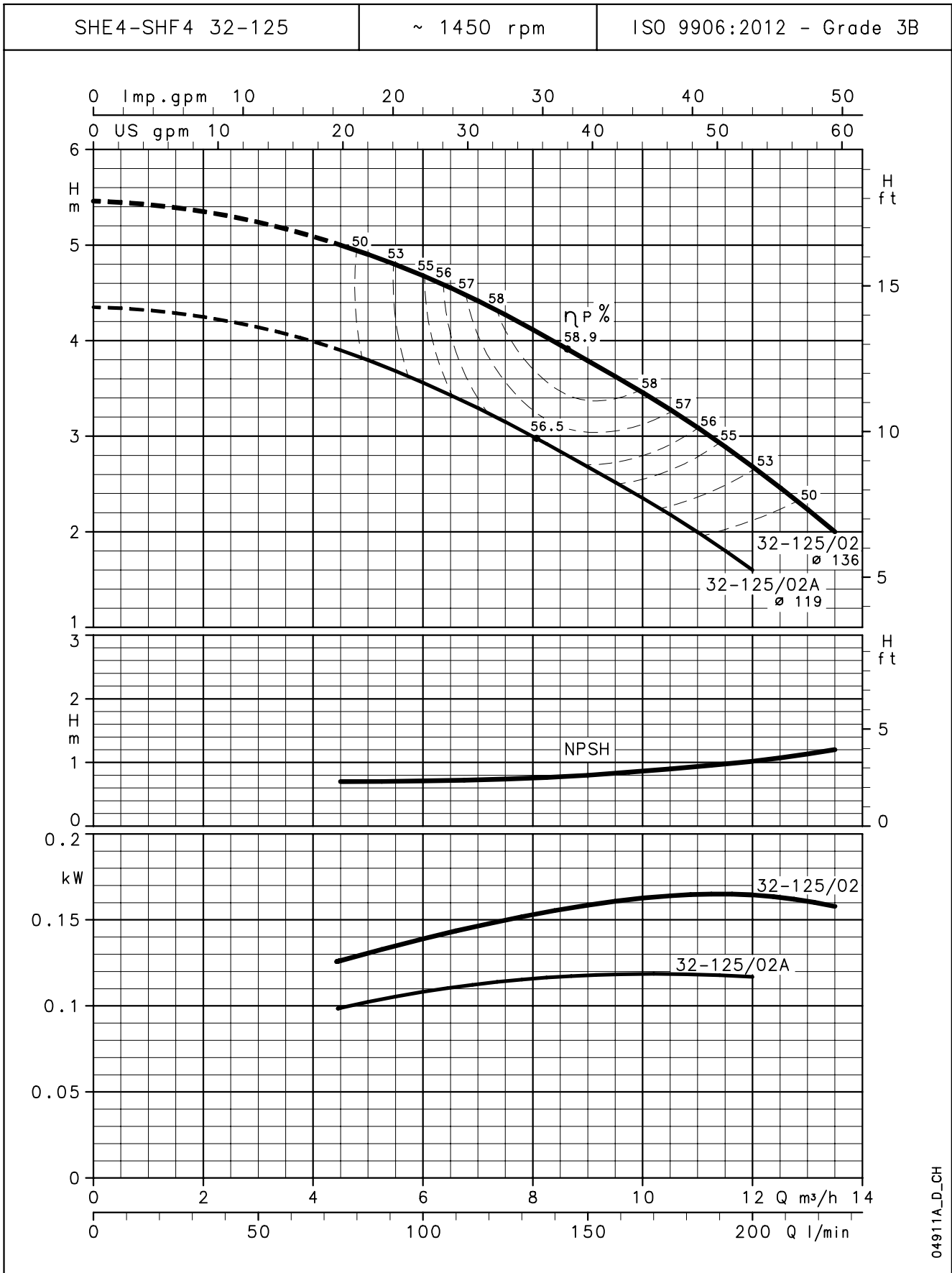

04911A_D_CH

The NPSH values are laboratory values; for practical use we suggest increasing these values by 0,5 m.
These performances are valid for liquids with density $\rho = 1,0 \text{ Kg/dm}^3$ and kinematic viscosity $\nu = 1 \text{ mm}^2/\text{sec}$.

**SHE4-SHF4 SERIES
OPERATING CHARACTERISTICS AT 50 Hz, 4 POLES**

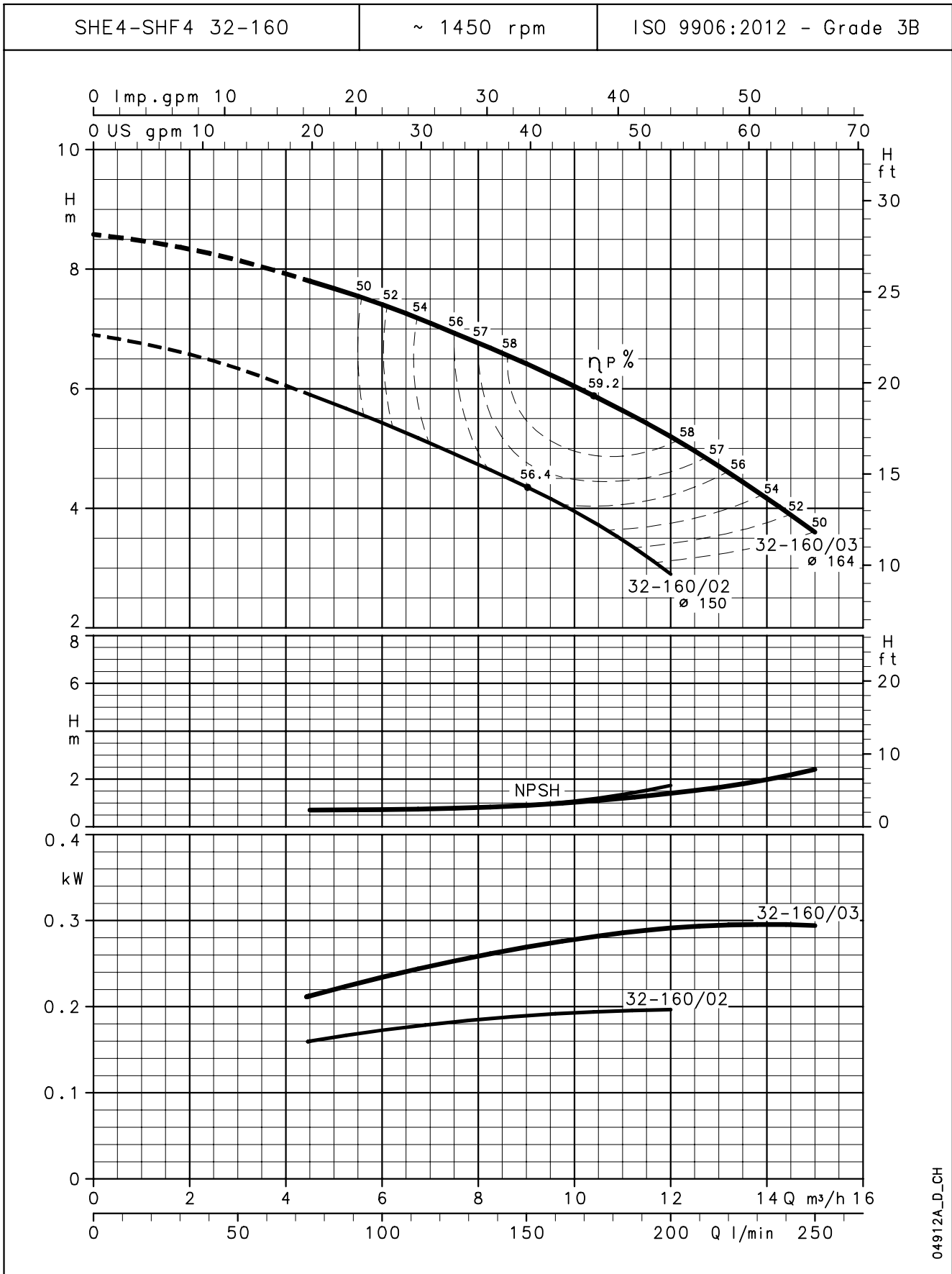

04912A_D_CH

The NPSH values are laboratory values; for practical use we suggest increasing these values by 0,5 m.
These performances are valid for liquids with density $\rho = 1,0 \text{ Kg/dm}^3$ and kinematic viscosity $\nu = 1 \text{ mm}^2/\text{sec}$.

**SHE4-SHF4 SERIES
OPERATING CHARACTERISTICS AT 50 Hz, 4 POLES**

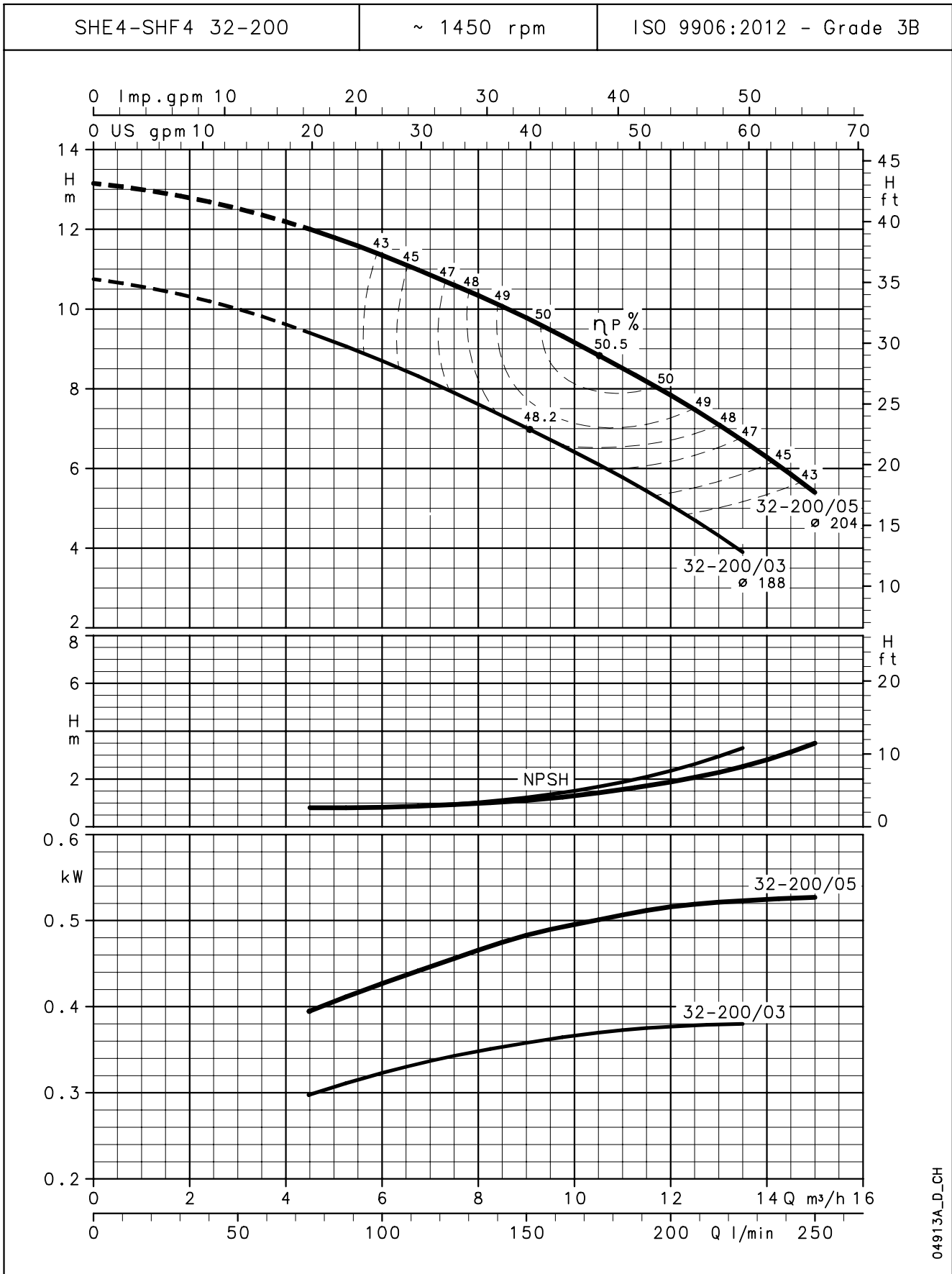

04913A_D_CH

The NPSH values are laboratory values; for practical use we suggest increasing these values by 0,5 m.
 These performances are valid for liquids with density $\rho = 1,0 \text{ Kg/dm}^3$ and kinematic viscosity $\nu = 1 \text{ mm}^2/\text{sec}$.

**SHE4-SHS4-SHF4 SERIES
OPERATING CHARACTERISTICS AT 50 Hz, 4 POLES**

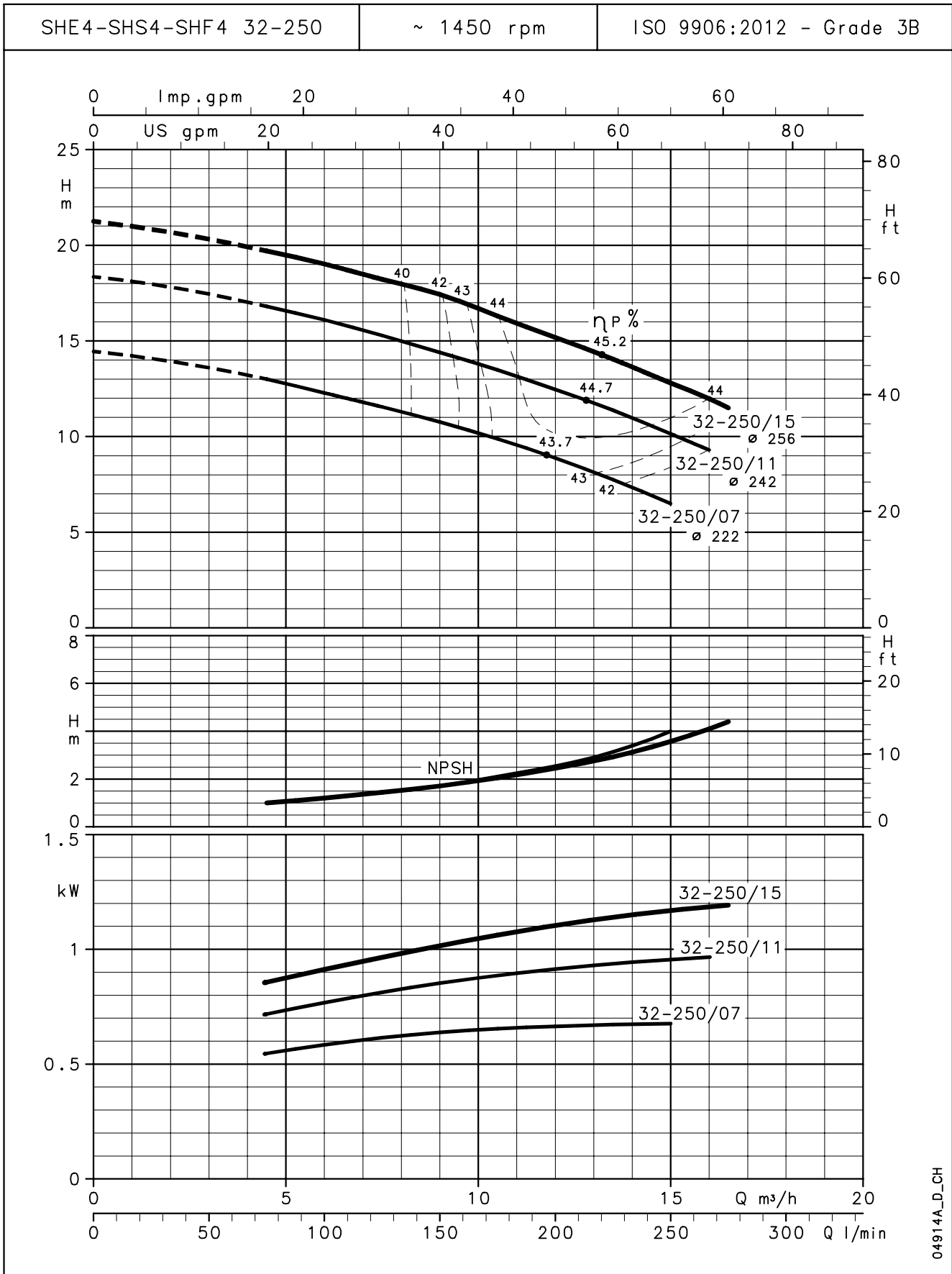

04914A_D_CH

The NPSH values are laboratory values; for practical use we suggest increasing these values by 0,5 m.
These performances are valid for liquids with density $\rho = 1,0 \text{ Kg/dm}^3$ and kinematic viscosity $\nu = 1 \text{ mm}^2/\text{sec}$.

**SHE4-SHF4 SERIES
OPERATING CHARACTERISTICS AT 50 Hz, 4 POLES**

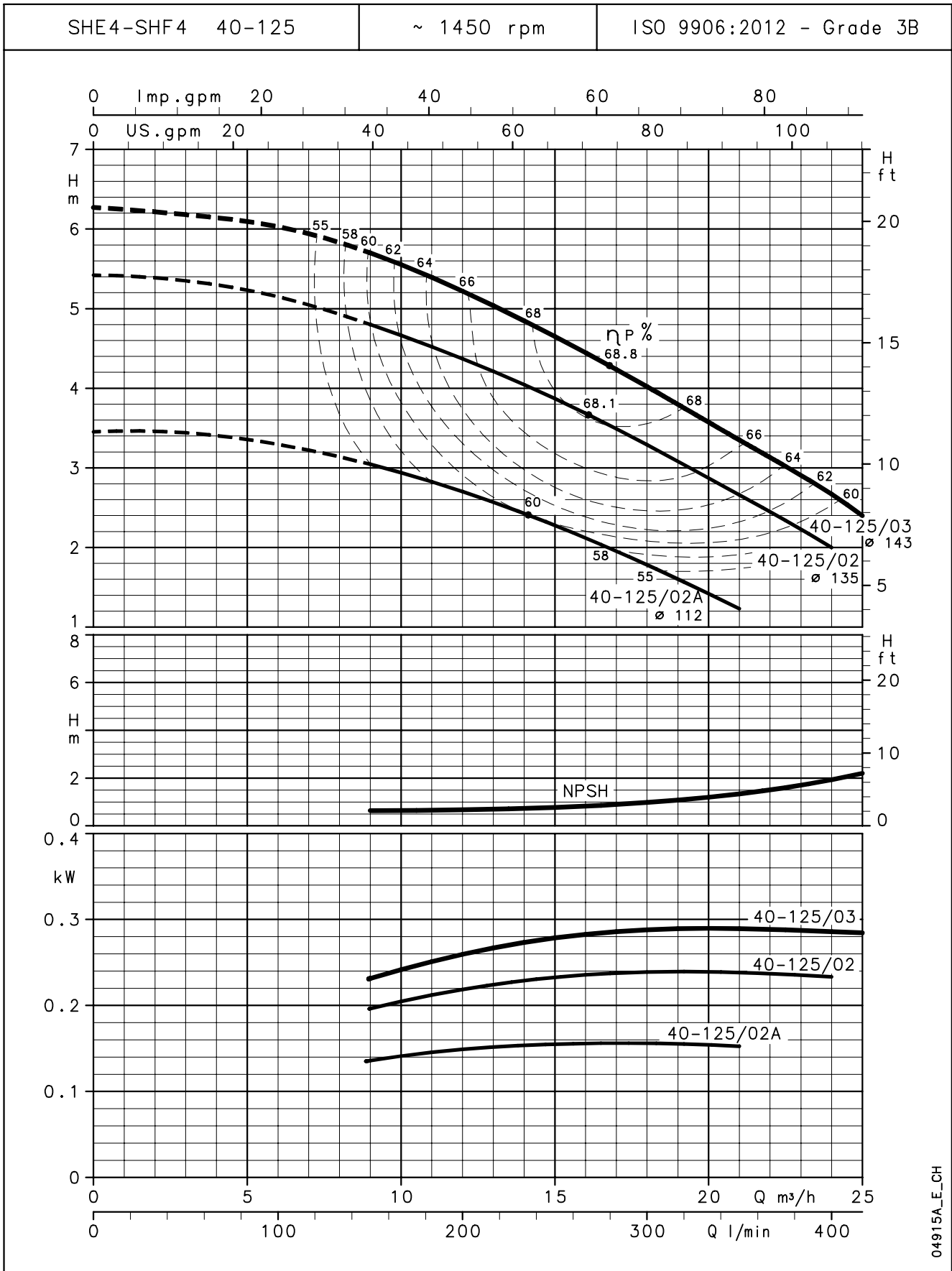

04915A_E_CH

The NPSH values are laboratory values; for practical use we suggest increasing these values by 0,5 m.
These performances are valid for liquids with density $\rho = 1,0 \text{ Kg/dm}^3$ and kinematic viscosity $\nu = 1 \text{ mm}^2/\text{sec}$.

SHE4-SHF4 SERIES
OPERATING CHARACTERISTICS AT 50 Hz, 4 POLES

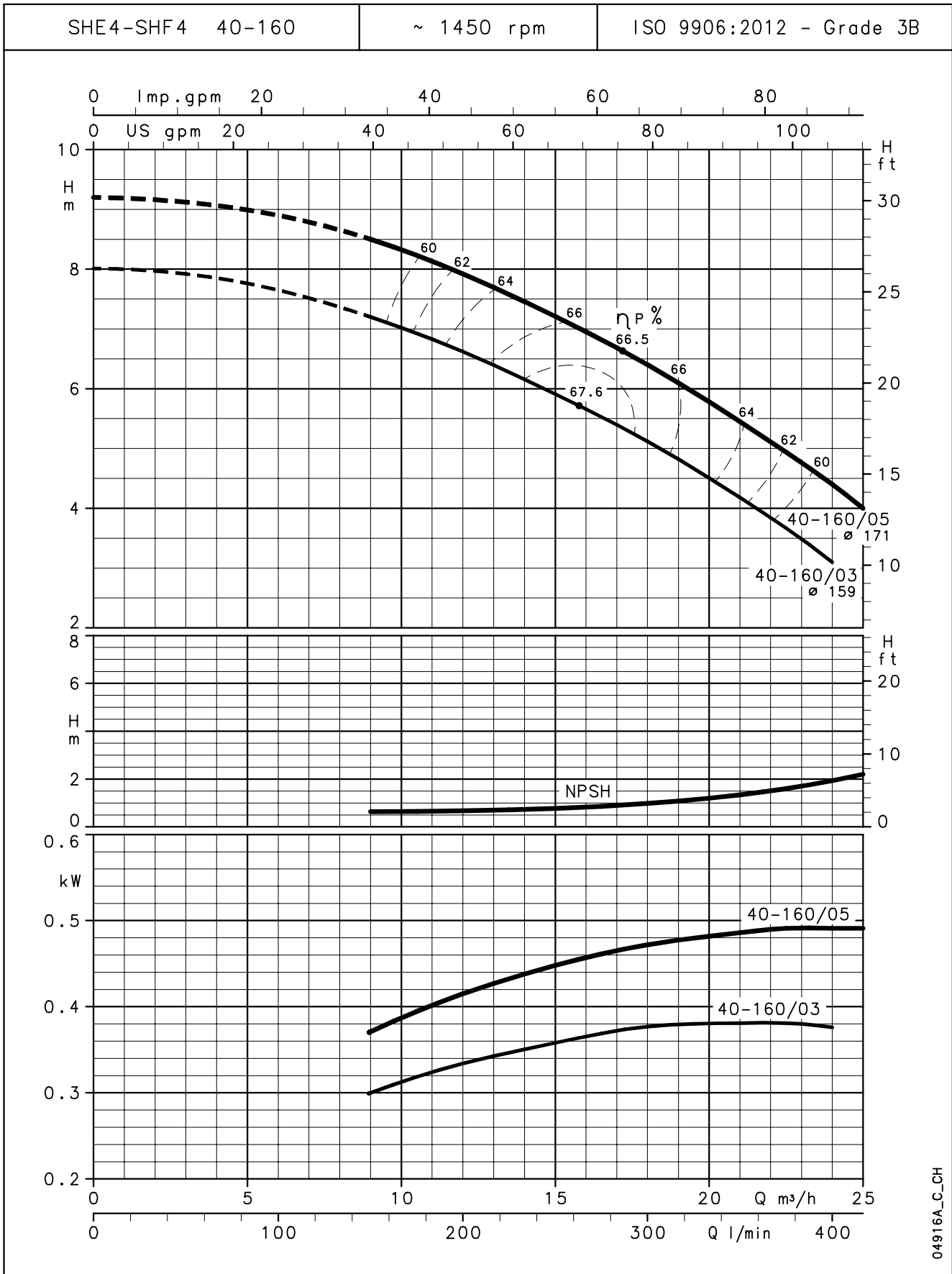

04916A_C-CH

The NPSH values are laboratory values; for practical use we suggest increasing these values by 0,5 m.
 These performances are valid for liquids with density $\rho = 1,0 \text{ Kg/dm}^3$ and kinematic viscosity $\nu = 1 \text{ mm}^2/\text{sec}$.

**SHE4-SHS4-SHF4 SERIES
OPERATING CHARACTERISTICS AT 50 Hz, 4 POLES**

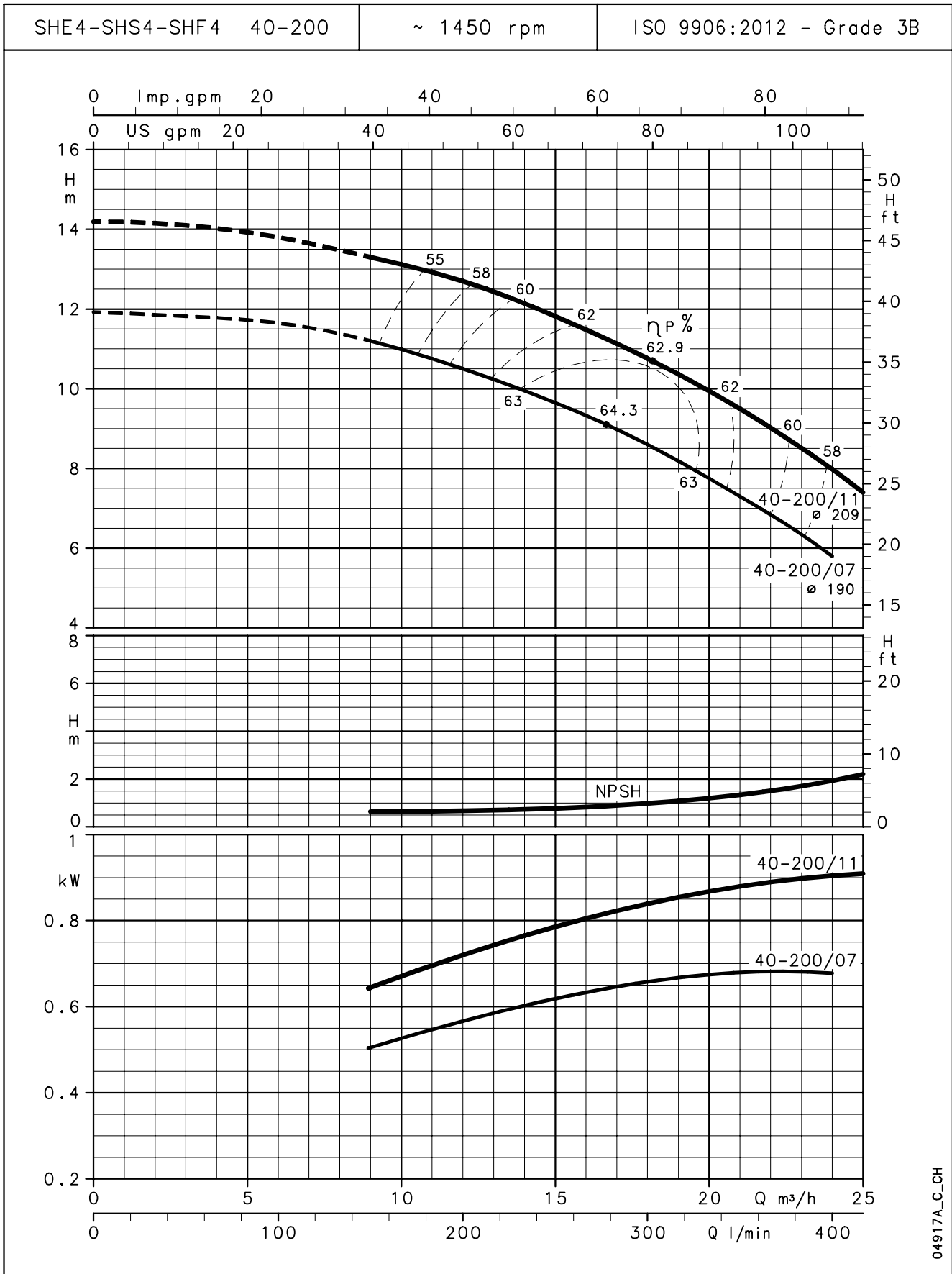

04917A_C-CH

The NPSH values are laboratory values; for practical use we suggest increasing these values by 0,5 m.
These performances are valid for liquids with density $\rho = 1,0 \text{ Kg/dm}^3$ and kinematic viscosity $\nu = 1 \text{ mm}^2/\text{sec}$.

SHE4-SHS4-SHF4 SERIES
OPERATING CHARACTERISTICS AT 50 Hz, 4 POLES

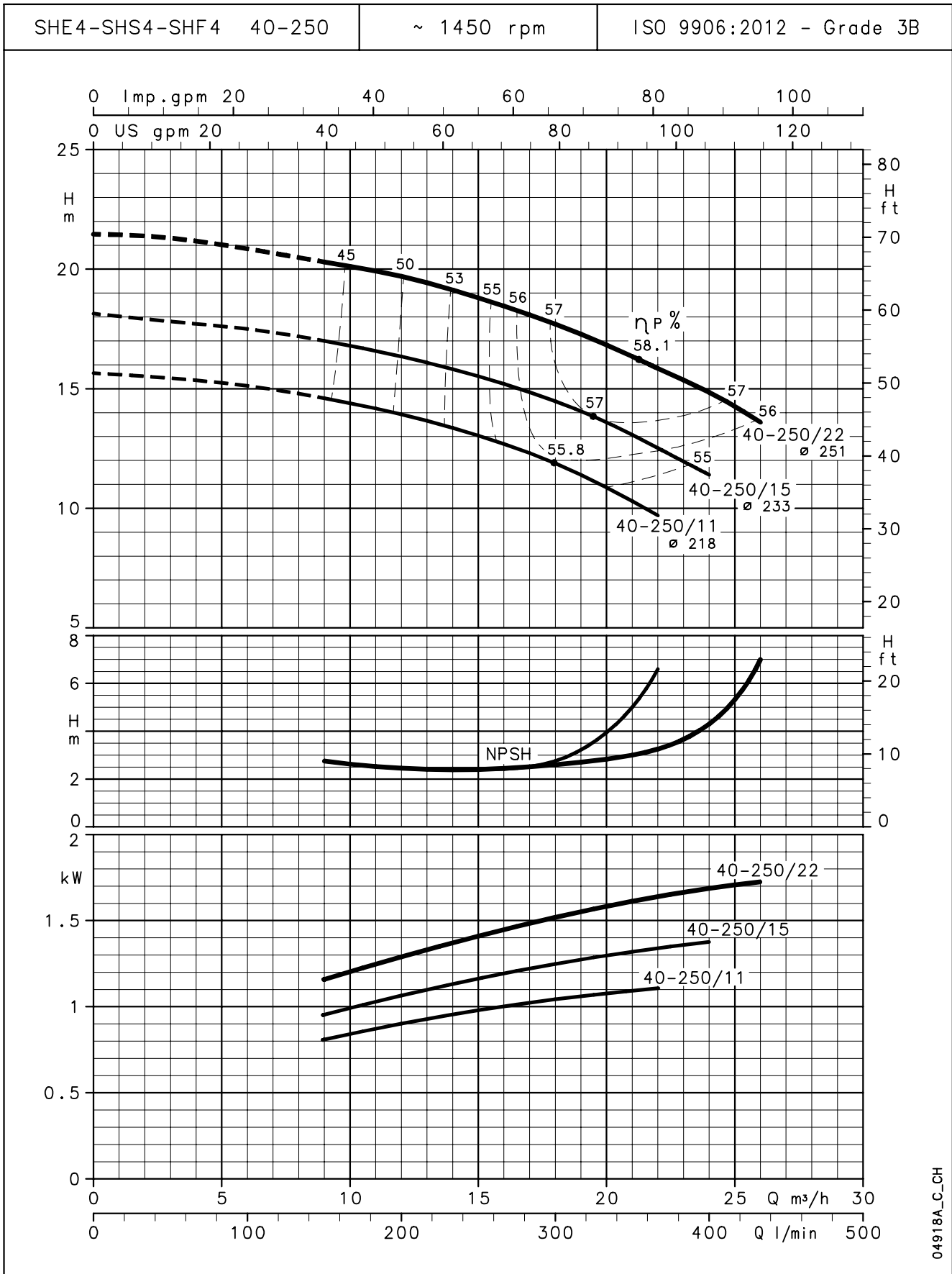

04918A_C-CH

The NPSH values are laboratory values; for practical use we suggest increasing these values by 0,5 m.
 These performances are valid for liquids with density ρ = 1,0 Kg/dm³ and kinematic viscosity ν = 1 mm²/sec.

**SHE4-SHF4 SERIES
OPERATING CHARACTERISTICS AT 50 Hz, 4 POLES**

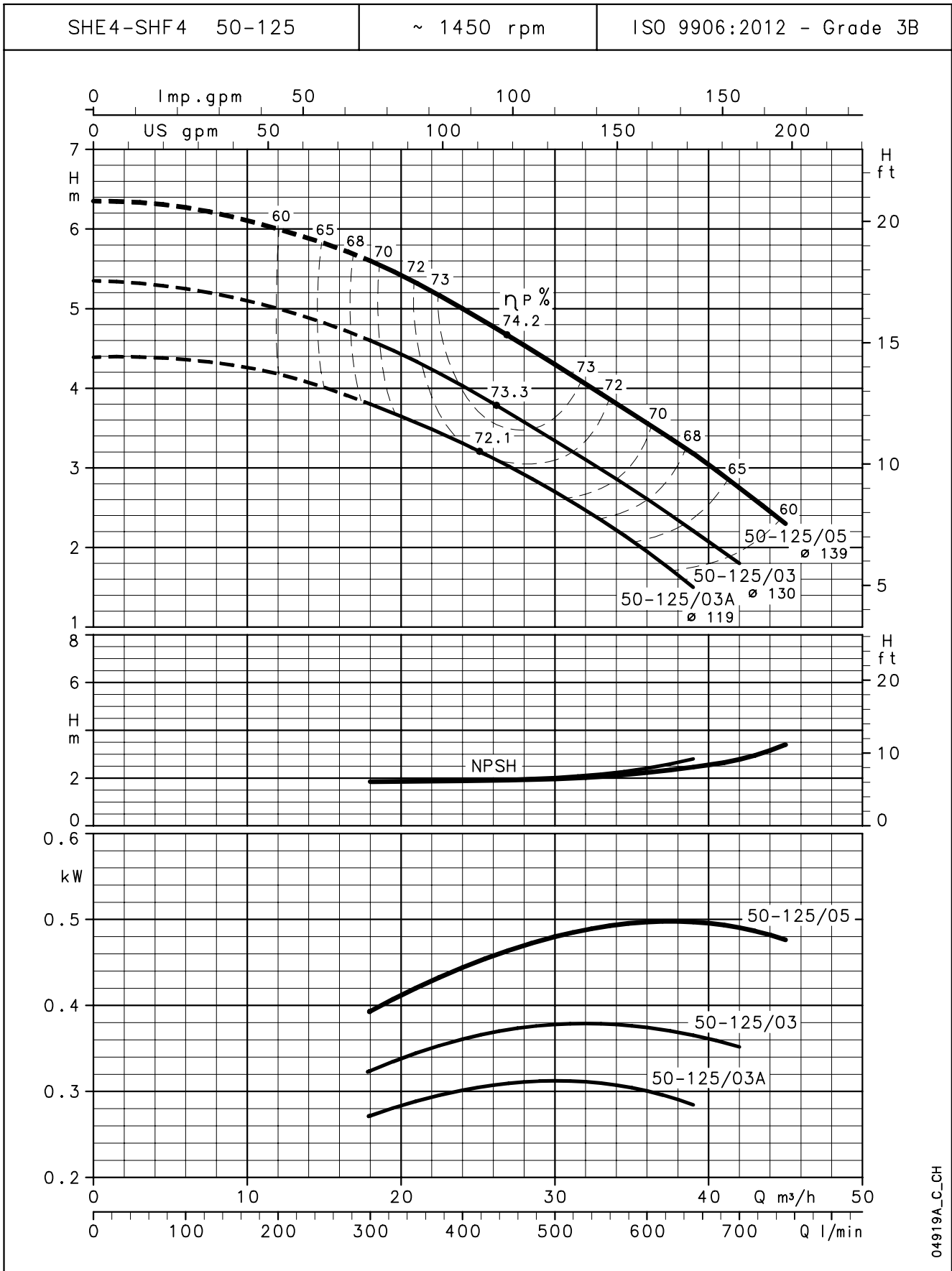

04919A_C_CH

The NPSH values are laboratory values; for practical use we suggest increasing these values by 0,5 m.
These performances are valid for liquids with density $\rho = 1,0 \text{ Kg/dm}^3$ and kinematic viscosity $\nu = 1 \text{ mm}^2/\text{sec}$.

**SHE4-SHS4-SHF4 SERIES
OPERATING CHARACTERISTICS AT 50 Hz, 4 POLES**

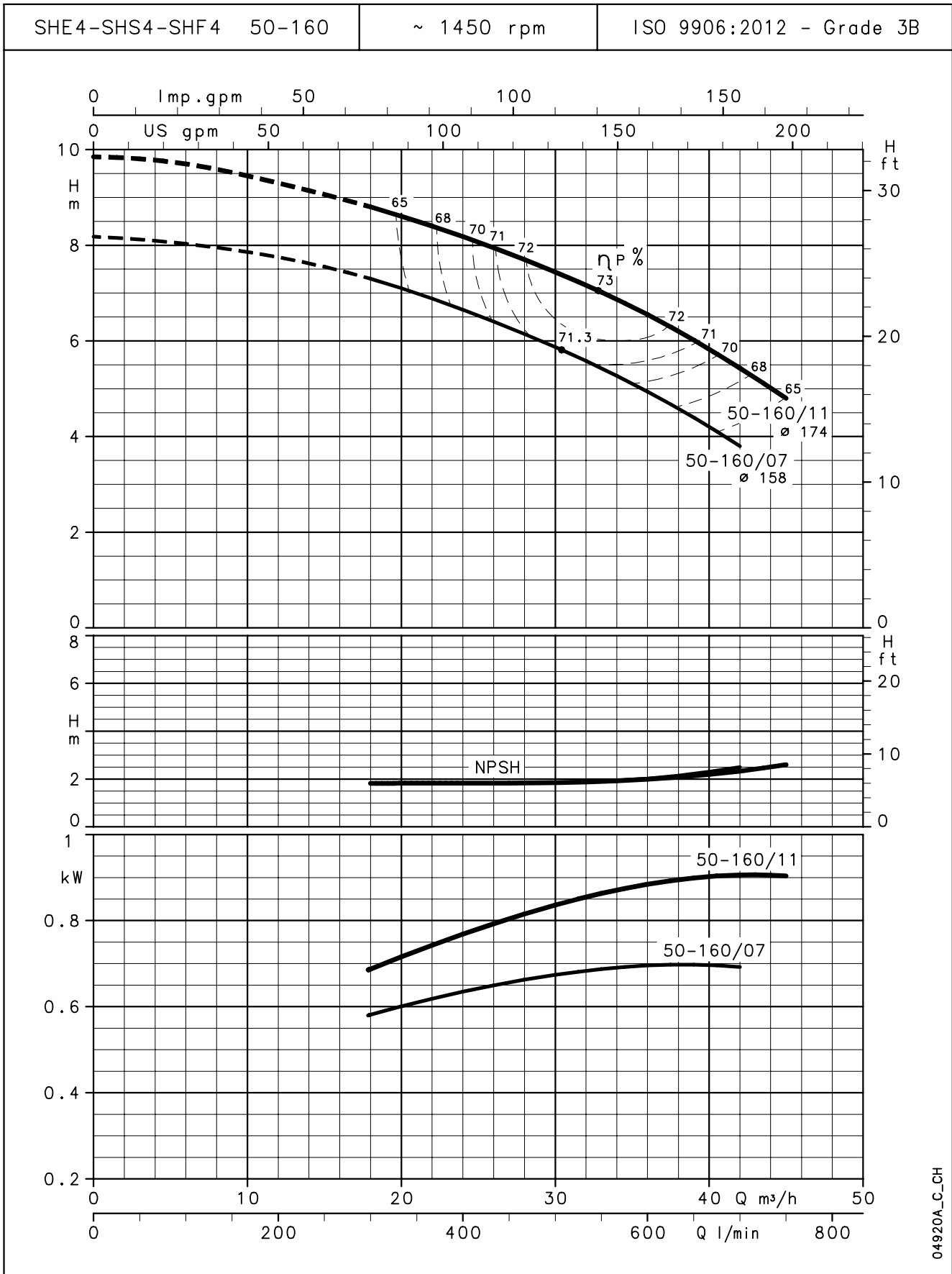

04920A_C_CH

The NPSH values are laboratory values; for practical use we suggest increasing these values by 0,5 m.
These performances are valid for liquids with density $\rho = 1,0 \text{ Kg/dm}^3$ and kinematic viscosity $\nu = 1 \text{ mm}^2/\text{sec}$.

**SHE4-SHS4-SHF4 SERIES
OPERATING CHARACTERISTICS AT 50 Hz, 4 POLES**

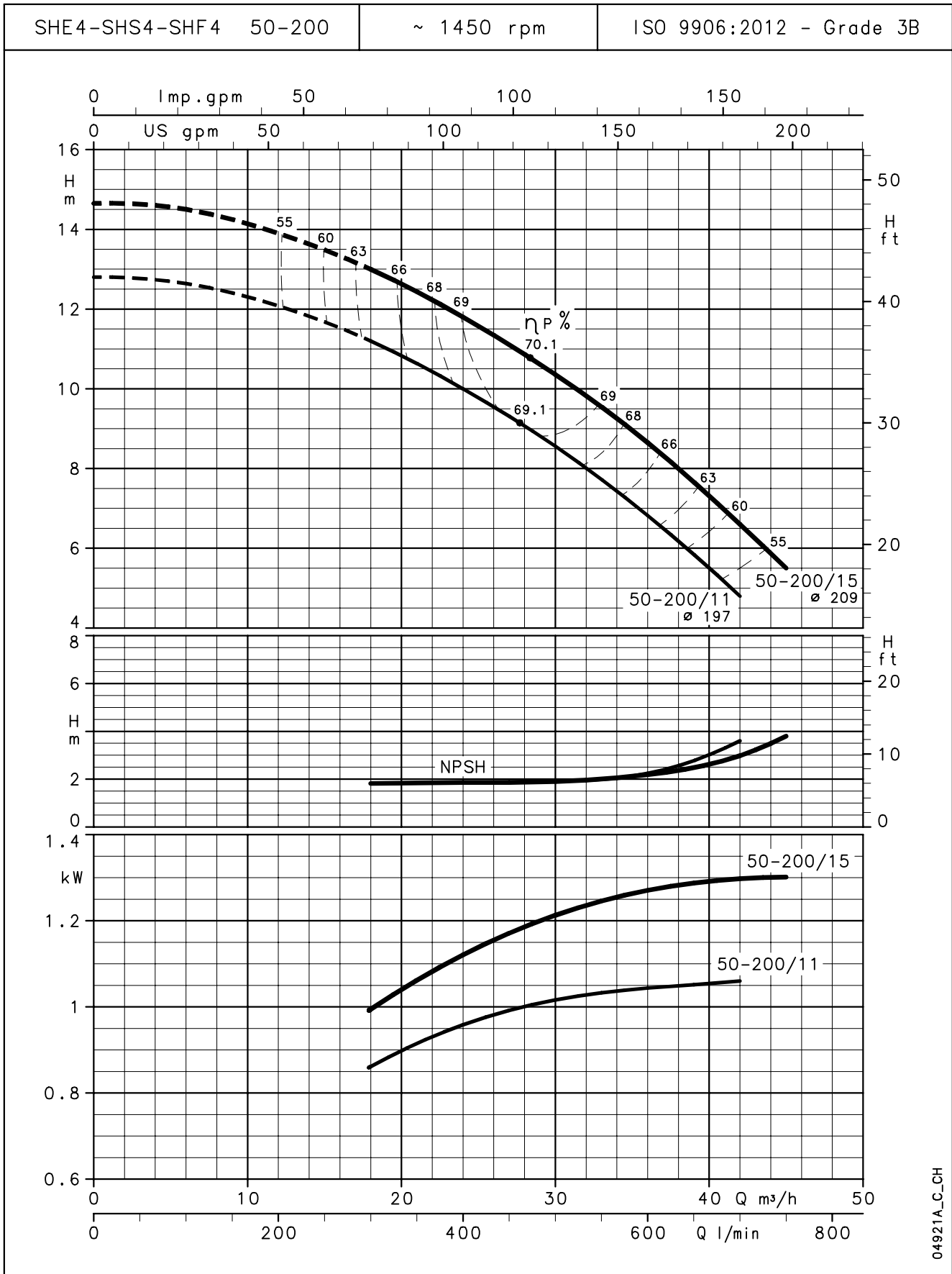

04921A_C-CH

The NPSH values are laboratory values; for practical use we suggest increasing these values by 0,5 m.
These performances are valid for liquids with density $\rho = 1,0 \text{ Kg/dm}^3$ and kinematic viscosity $\nu = 1 \text{ mm}^2/\text{sec}$.

**SHE4-SHS4-SHF4 SERIES
OPERATING CHARACTERISTICS AT 50 Hz, 4 POLES**

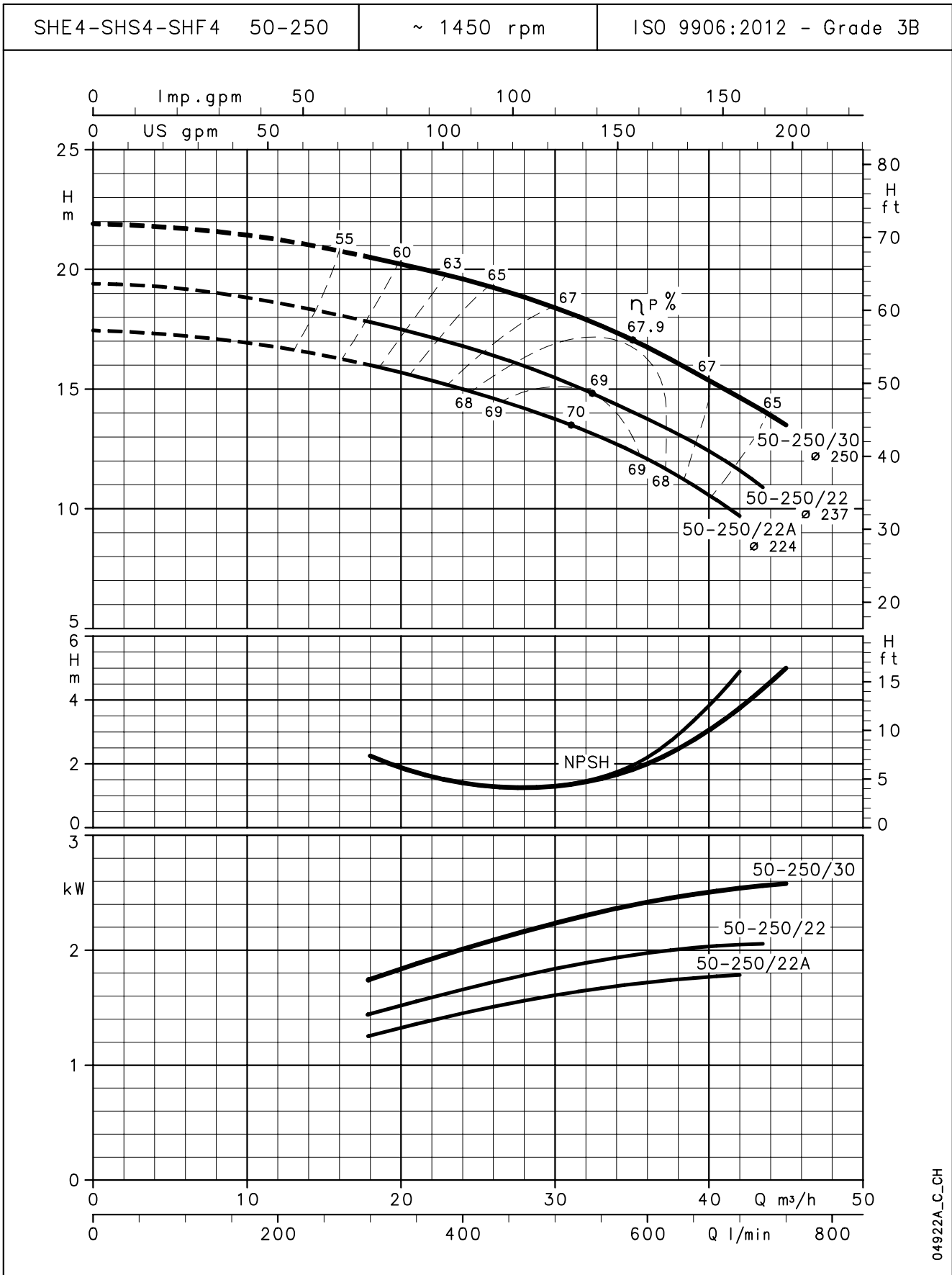

04922A_C_CH

The NPSH values are laboratory values; for practical use we suggest increasing these values by 0,5 m.
These performances are valid for liquids with density $\rho = 1,0 \text{ Kg/dm}^3$ and kinematic viscosity $\nu = 1 \text{ mm}^2/\text{sec}$.

**SHE4-SHS4-SHF4 SERIES
OPERATING CHARACTERISTICS AT 50 Hz, 4 POLES**

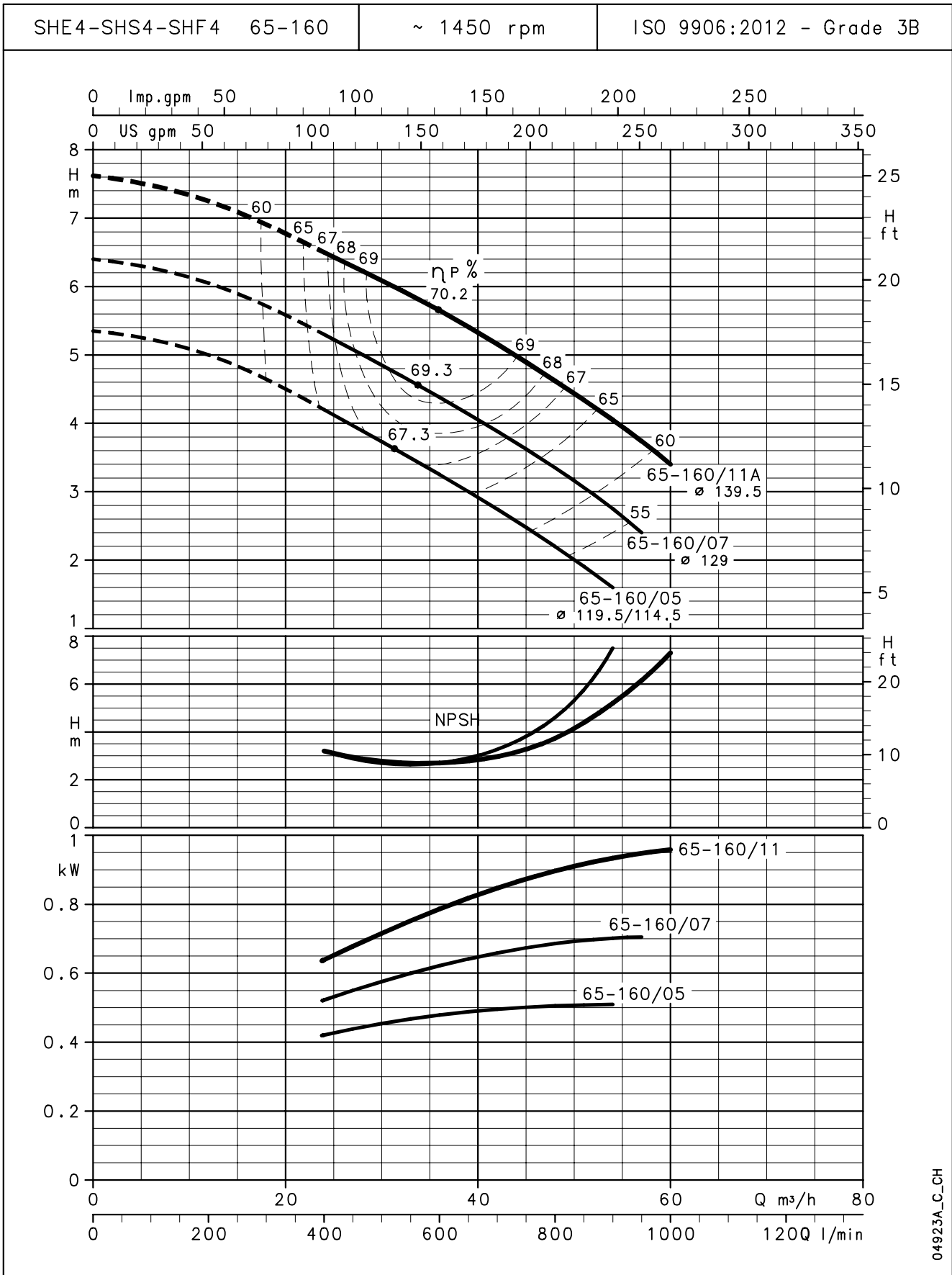

04923A_C_CH

The NPSH values are laboratory values; for practical use we suggest increasing these values by 0,5 m.
These performances are valid for liquids with density $\rho = 1,0 \text{ Kg/dm}^3$ and kinematic viscosity $\nu = 1 \text{ mm}^2/\text{sec}$.

SHE4-SHS4-SHF4 SERIES
OPERATING CHARACTERISTICS AT 50 Hz, 4 POLES

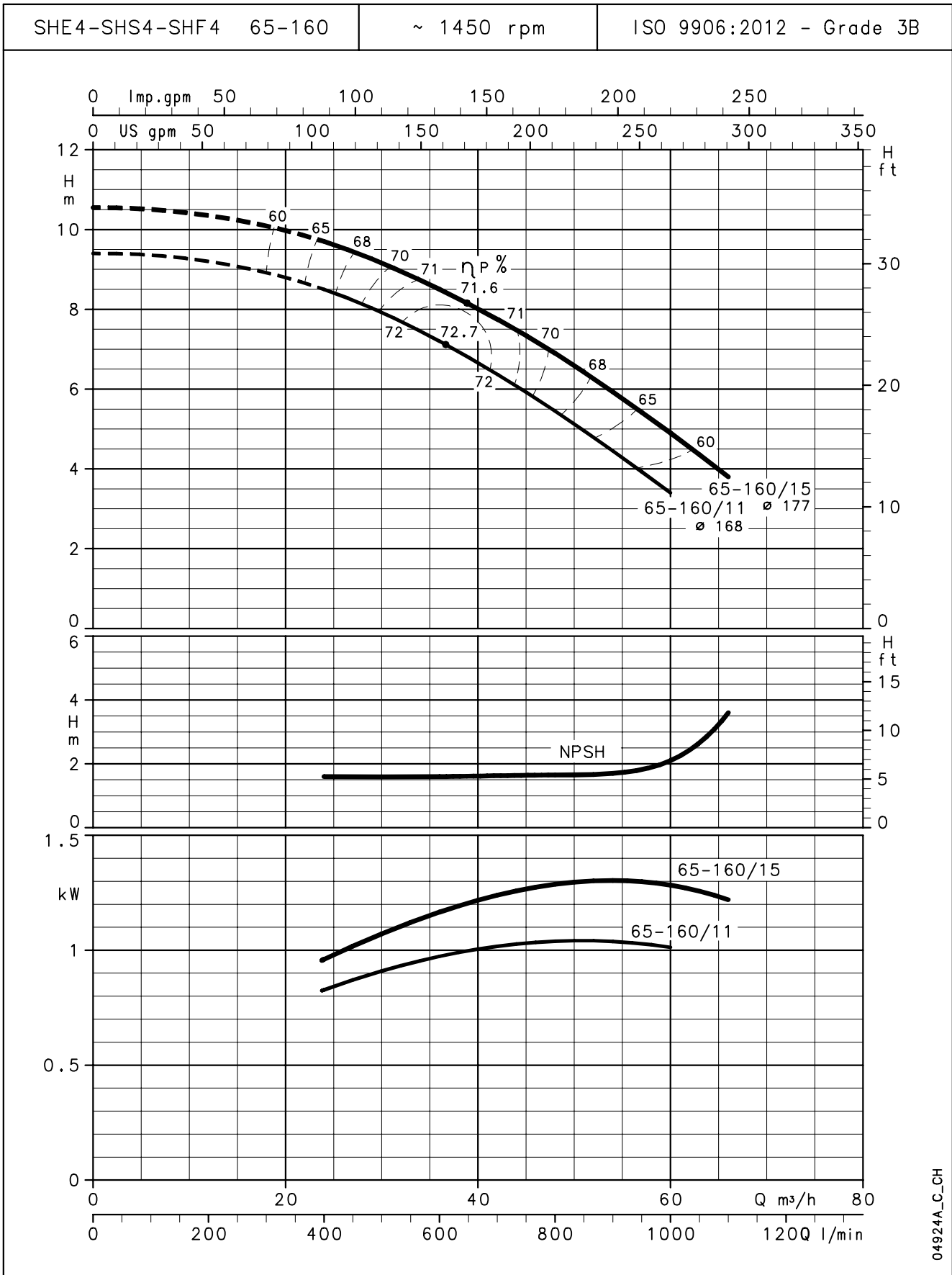

04924A_C_CH

The NPSH values are laboratory values; for practical use we suggest increasing these values by 0,5 m.
 These performances are valid for liquids with density $\rho = 1,0 \text{ Kg/dm}^3$ and kinematic viscosity $\nu = 1 \text{ mm}^2/\text{sec}$.

SHE4-SHS4-SHF4 SERIES
OPERATING CHARACTERISTICS AT 50 Hz, 4 POLES

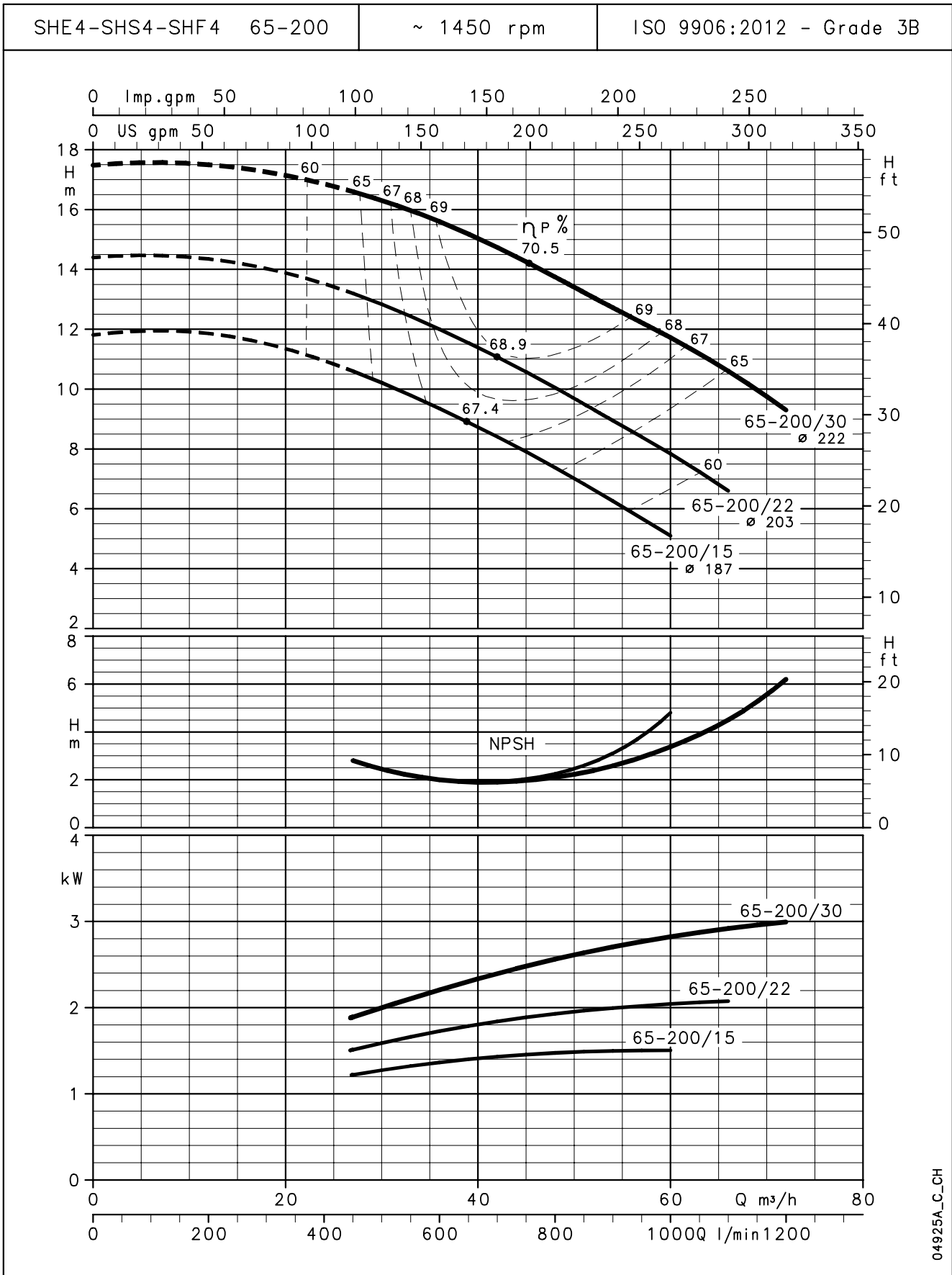

04925A_C_CH

The NPSH values are laboratory values; for practical use we suggest increasing these values by 0,5 m.
 These performances are valid for liquids with density $\rho = 1,0 \text{ Kg/dm}^3$ and kinematic viscosity $\nu = 1 \text{ mm}^2/\text{sec}$.

SHE4-SHS4-SHF4 SERIES OPERATING CHARACTERISTICS AT 50 Hz, 4 POLES

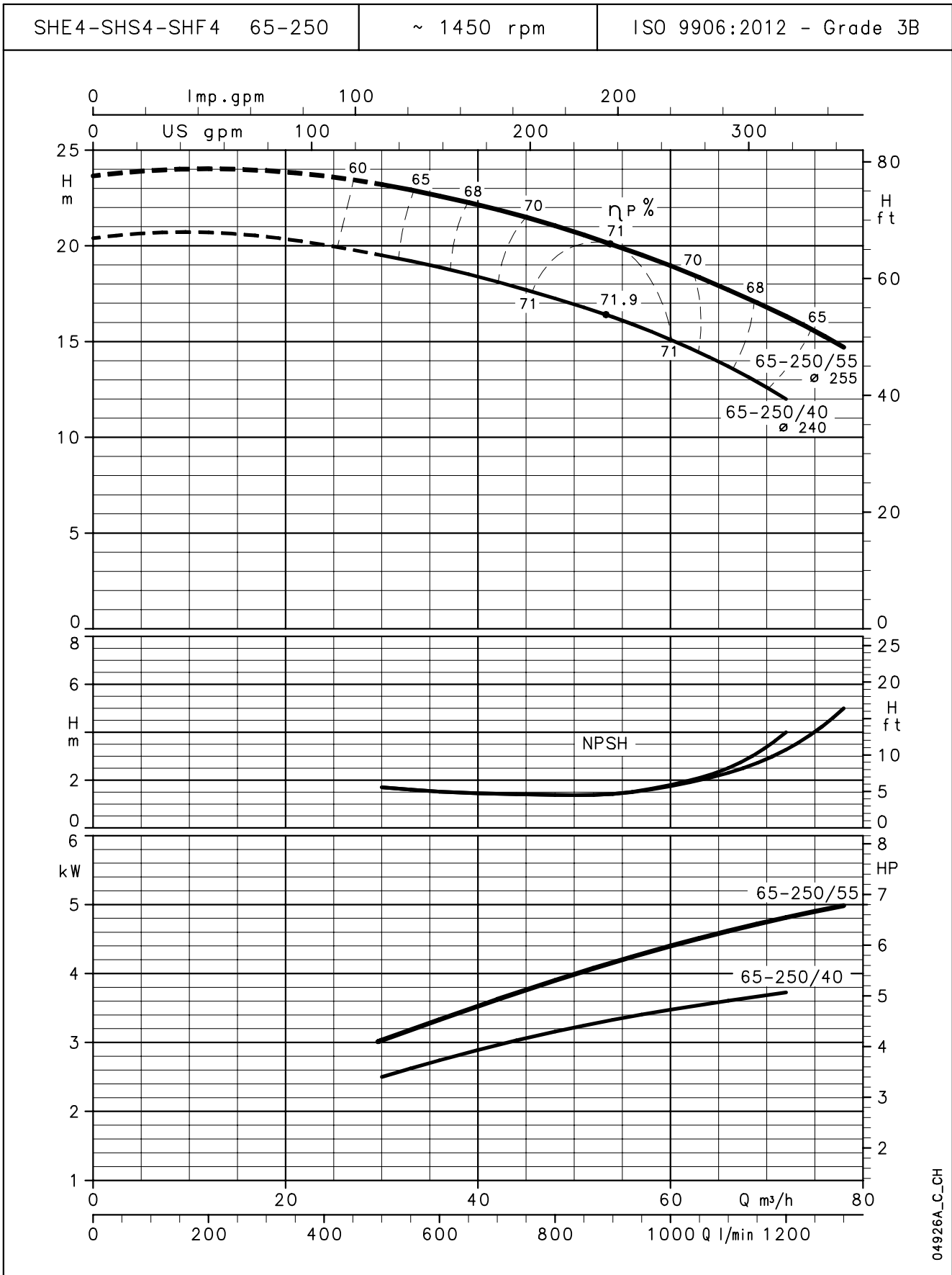

04926A_C_CH

The NPSH values are laboratory values; for practical use we suggest increasing these values by 0,5 m.
These performances are valid for liquids with density $\rho = 1,0 \text{ Kg/dm}^3$ and kinematic viscosity $\nu = 1 \text{ mm}^2/\text{sec}$.

SHE4-SHS4-SHF4 SERIES
OPERATING CHARACTERISTICS AT 50 Hz, 4 POLES

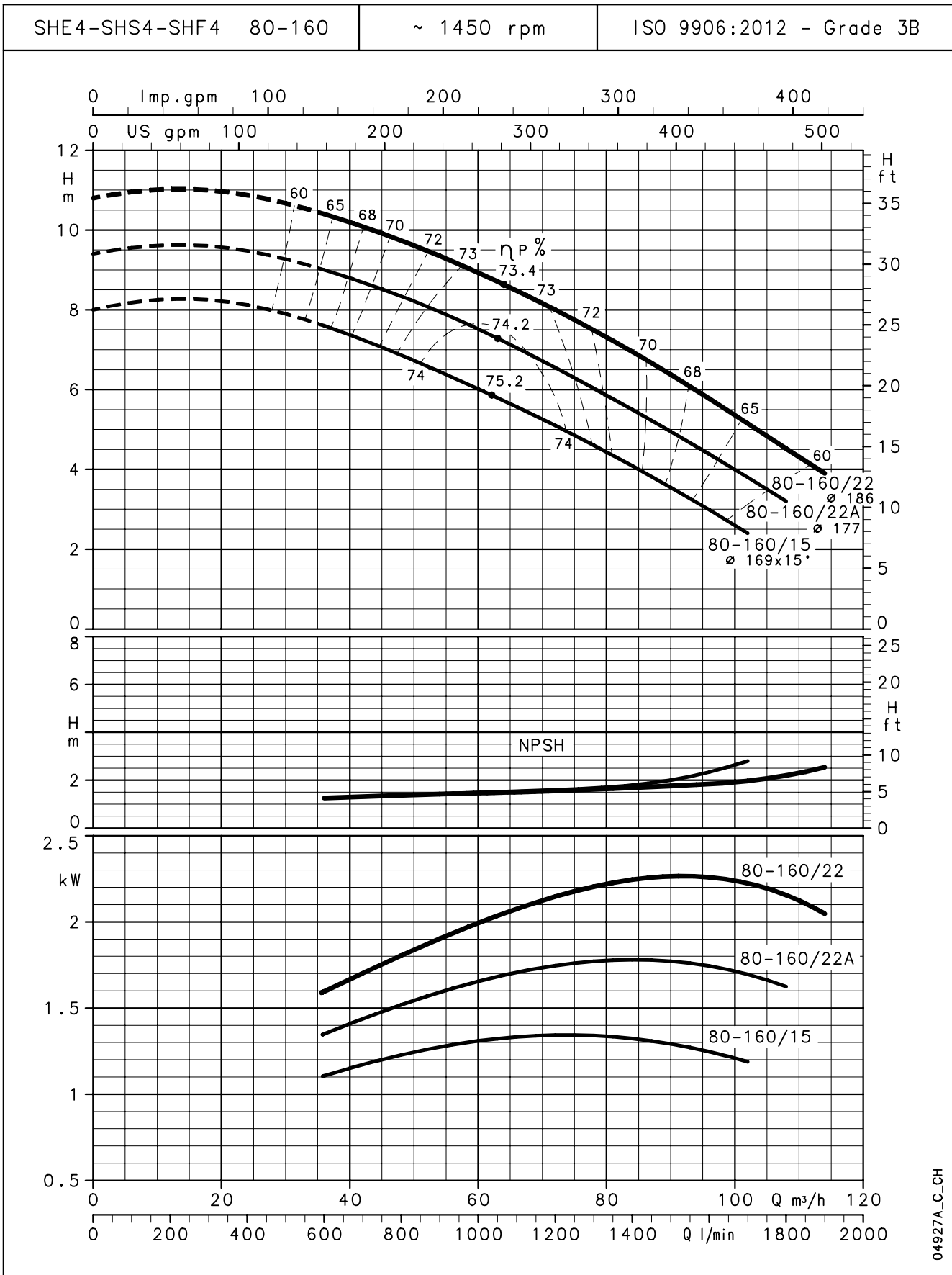

04927A_C-CH

The NPSH values are laboratory values; for practical use we suggest increasing these values by 0,5 m.
 These performances are valid for liquids with density $\rho = 1,0 \text{ Kg/dm}^3$ and kinematic viscosity $\nu = 1 \text{ mm}^2/\text{sec}$.

**SHE4-SHS4-SHF4 SERIES
OPERATING CHARACTERISTICS AT 50 Hz, 4 POLES**

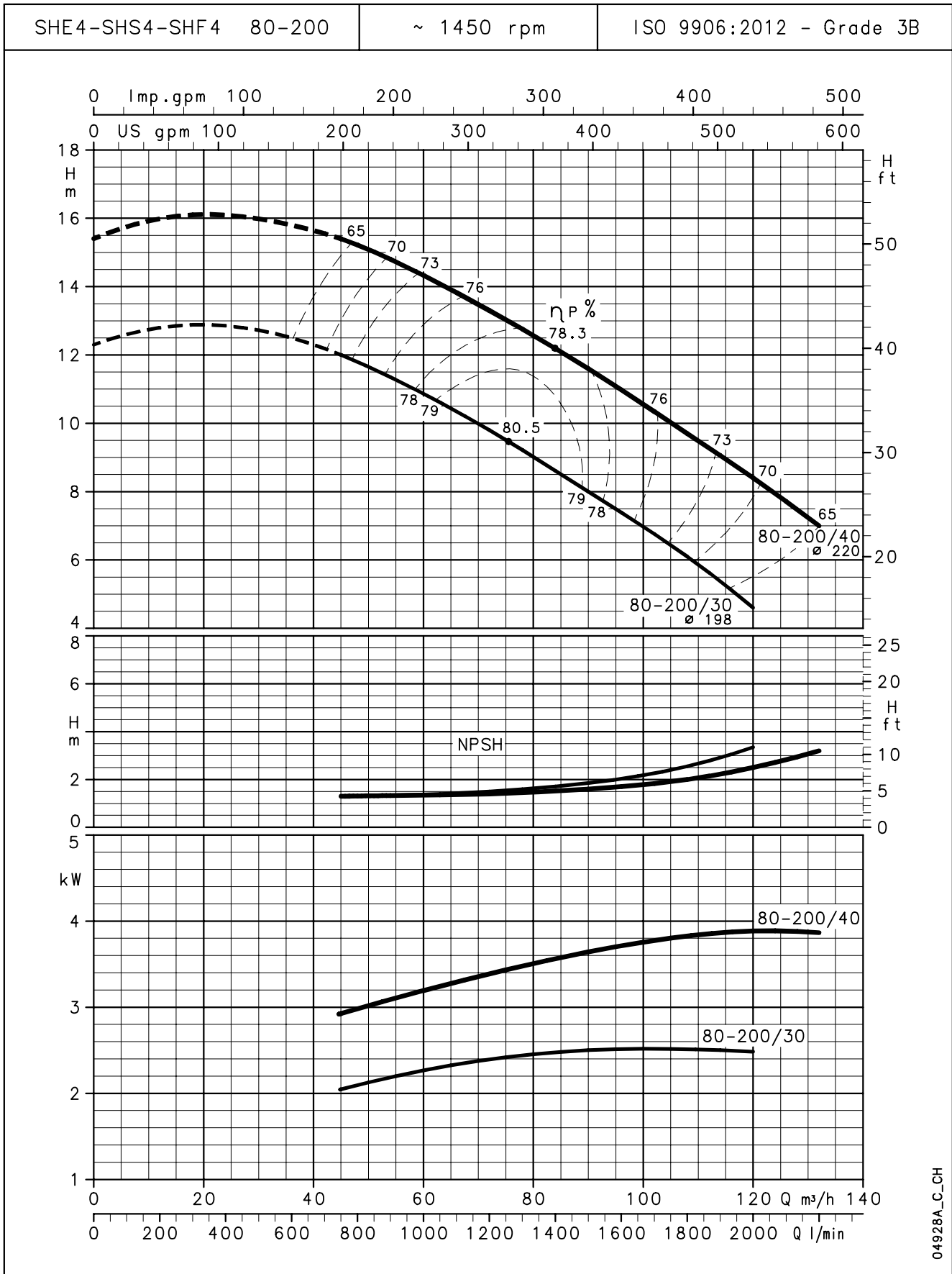

04928A_C_CH

The NPSH values are laboratory values; for practical use we suggest increasing these values by 0,5 m.
These performances are valid for liquids with density $\rho = 1,0 \text{ Kg/dm}^3$ and kinematic viscosity $\nu = 1 \text{ mm}^2/\text{sec}$.

**SHE4-SHS4-SHF4 SERIES
OPERATING CHARACTERISTICS AT 50 Hz, 4 POLES**

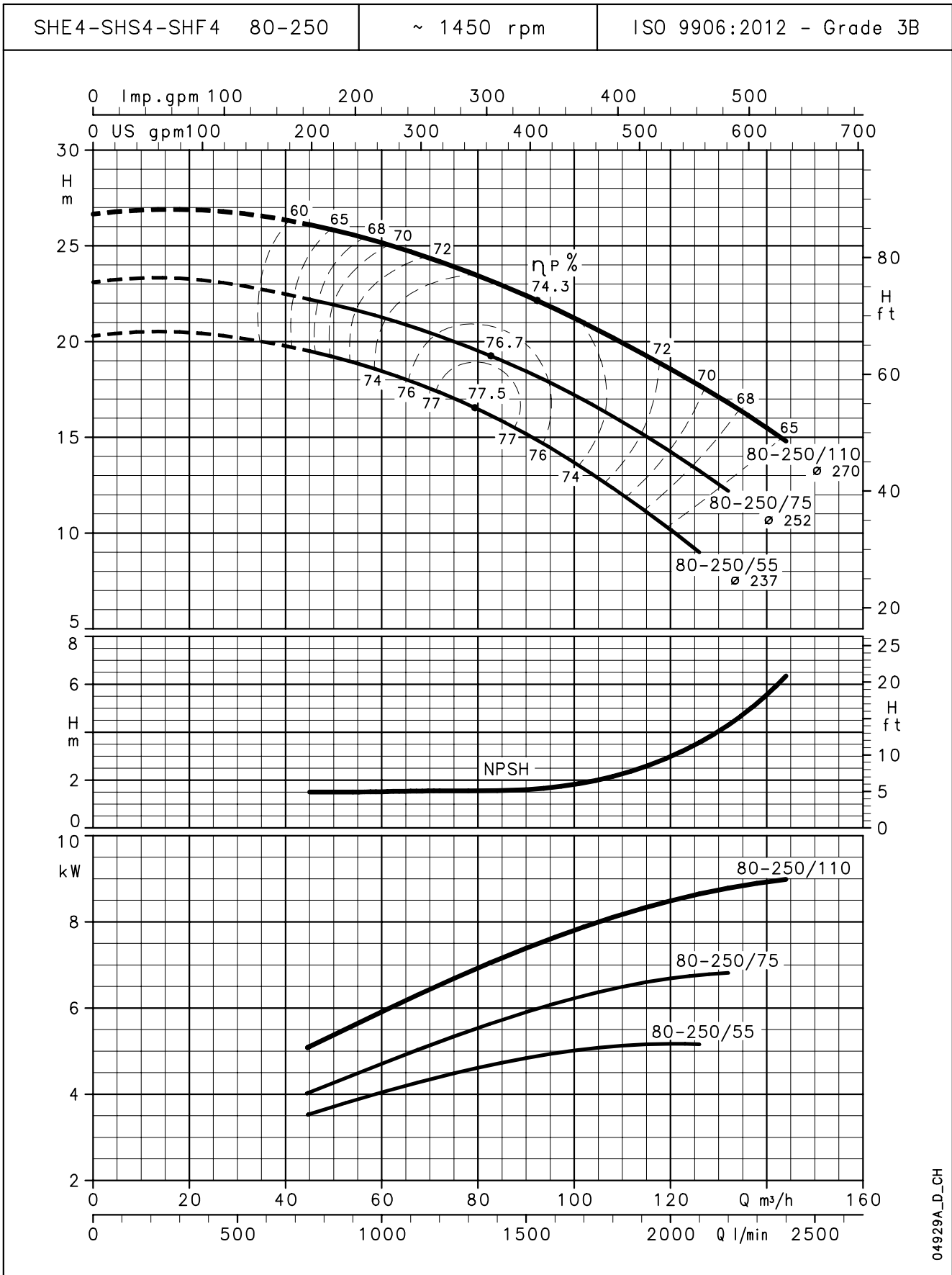

04929A_D_CH

The NPSH values are laboratory values; for practical use we suggest increasing these values by 0,5 m.
These performances are valid for liquids with density $\rho = 1,0 \text{ Kg/dm}^3$ and kinematic viscosity $\nu = 1 \text{ mm}^2/\text{sec}$.

DIMENSIONS AND WEIGHTS

**SHE SERIES
DIMENSIONS AND WEIGHTS AT 50 Hz, 2 POLES**

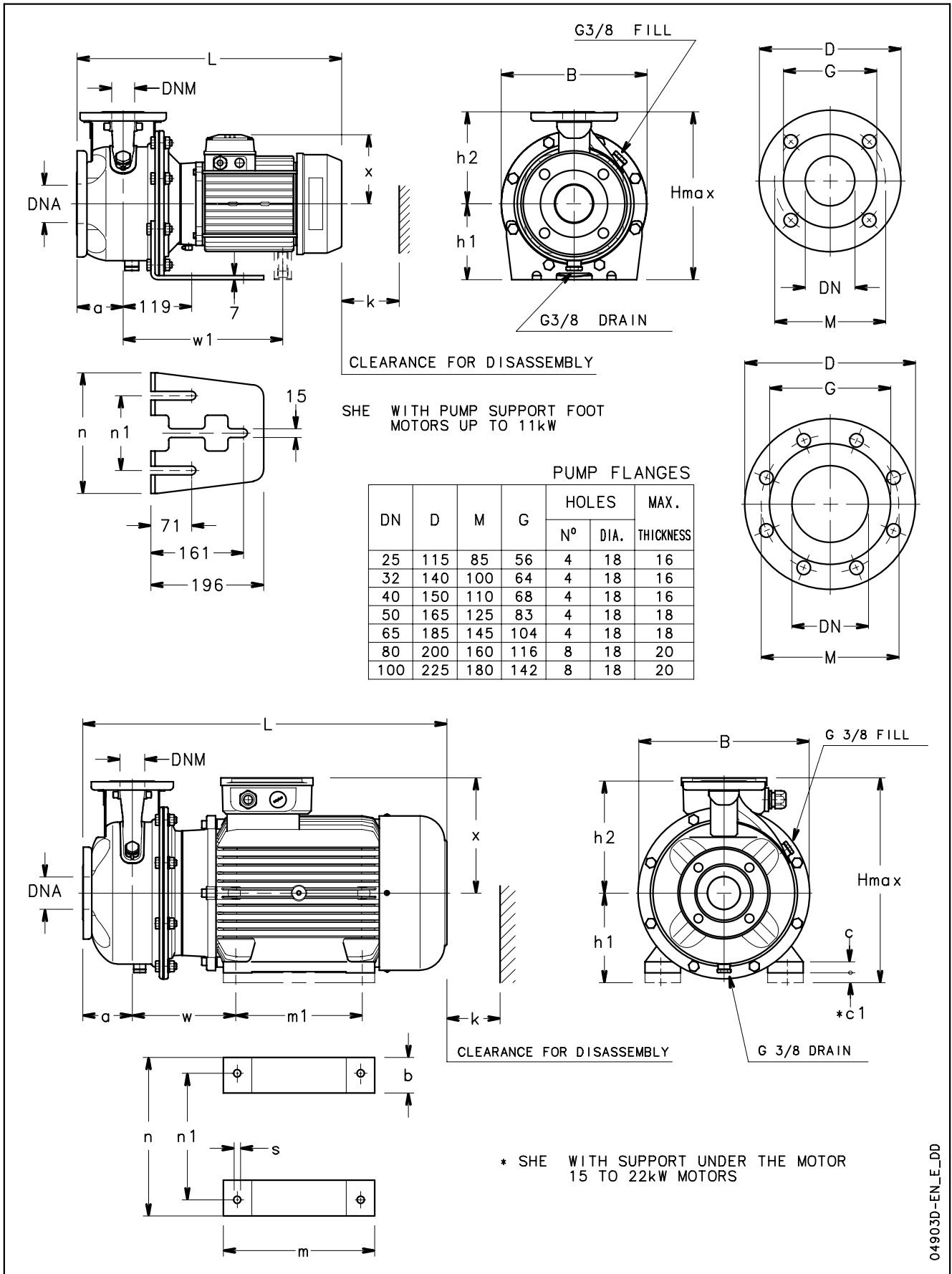

04903D-EN_E-DD

**SHE4 SERIES
DIMENSIONS AND WEIGHTS AT 50 Hz, 4 POLES**

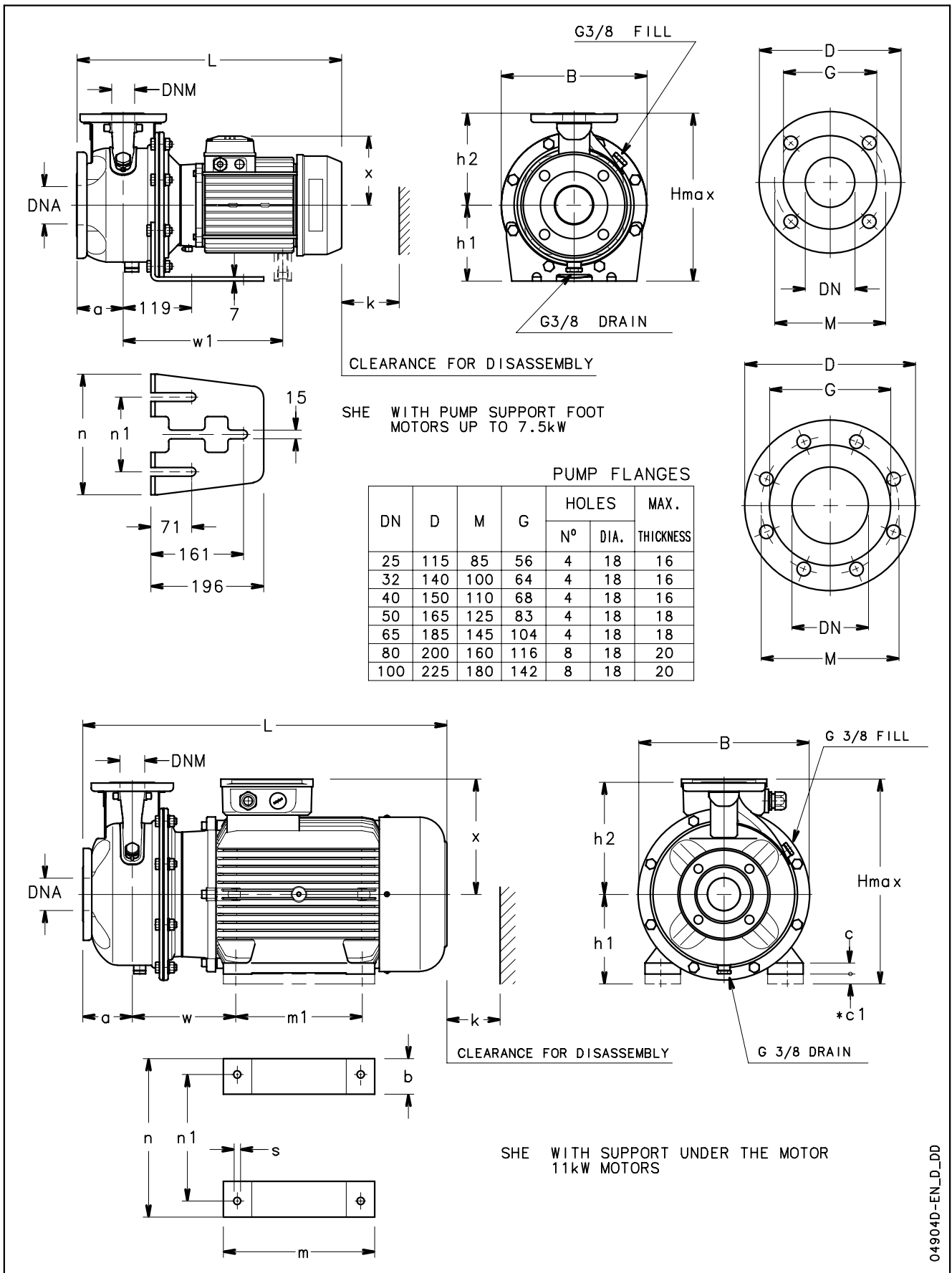

SHS SERIES DIMENSIONS AND WEIGHTS AT 50 Hz, 2 POLES

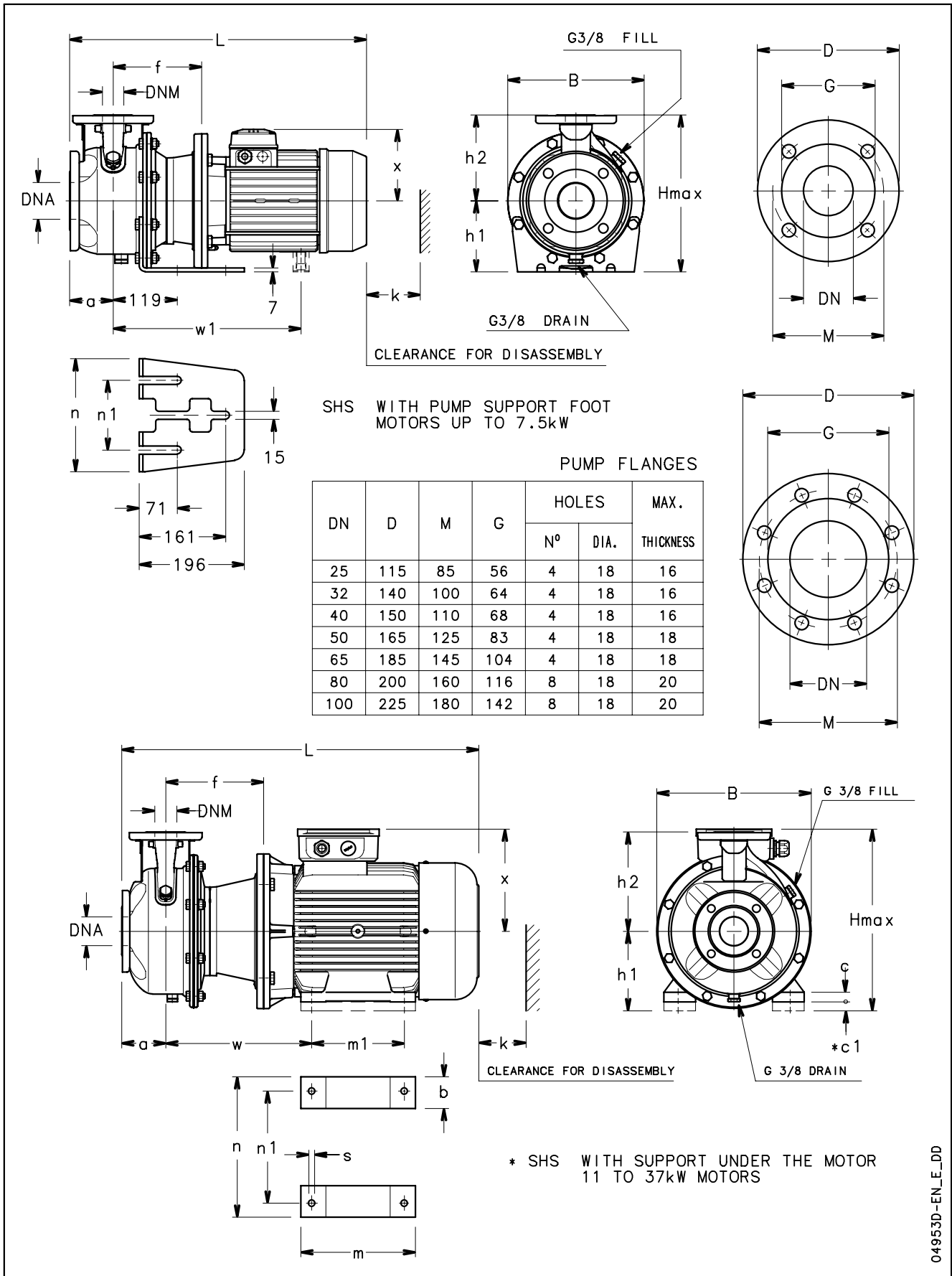

04953D-EN_E_DD

SHS4 SERIES DIMENSIONS AND WEIGHTS AT 50 Hz, 4 POLES

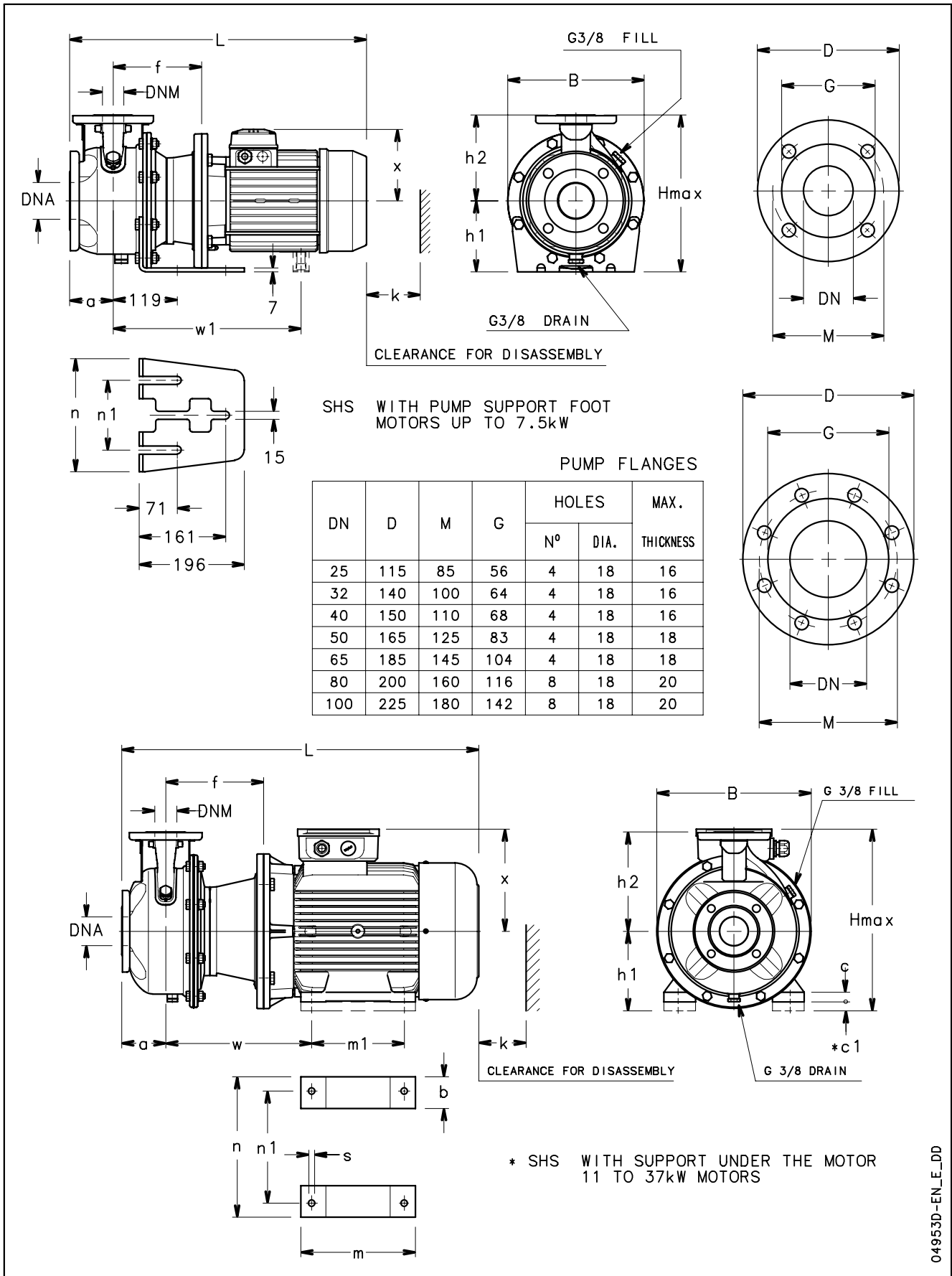

SHS4 SERIES DIMENSIONS AND WEIGHTS AT 50 Hz, 4 POLES

PUMP TYPE	DIMENSIONS (mm)																			WEIGHT kg			
	PUMP											SUPPORT							B		H max	L	k
	DNM	DNA	a	f	h2	w	w1	x	b	c	*c1	h1	m	m1	n	n1	s						
SHS4 25-250/07/C	25	50	100	155	225	-	-	128	-	-	-	180	-	-	265	130	-	345	405	486	98	42	
SHS4 25-250/11/P	25	50	100	155	225	-	-	134	-	-	-	180	-	-	265	130	-	345	405	553	98	49	
SHS4 25-250/15/P	25	50	100	155	225	-	-	134	-	-	-	180	-	-	265	130	-	345	405	553	98	50	
SHS4 32-250/07/C	32	50	100	155	225	-	-	128	-	-	-	180	-	-	265	130	-	345	405	486	98	42	
SHS4 32-250/11/P	32	50	100	155	225	-	-	134	-	-	-	180	-	-	265	130	-	345	405	553	98	49	
SHS4 32-250/15/P	32	50	100	155	225	-	-	134	-	-	-	180	-	-	265	130	-	345	405	553	98	50	
SHS4 40-200/07/C	40	65	100	155	180	-	-	128	-	-	-	160	-	-	230	130	-	284	340	486	100	31	
SHS4 40-200/11/P	40	65	100	155	180	-	-	134	-	-	-	160	-	-	230	130	-	284	340	553	100	37	
SHS4 40-250/11/P	40	65	100	155	225	-	-	134	-	-	-	180	-	-	265	130	-	345	405	553	107	51	
SHS4 40-250/15/P	40	65	100	155	225	-	-	134	-	-	-	180	-	-	265	130	-	345	405	553	107	64	
SHS4 40-250/22/P	40	65	100	165	225	-	-	168	-	-	-	180	-	-	265	130	-	345	405	587	107	68	
SHS4 50-160/07/C	50	65	100	155	180	-	-	128	-	-	-	160	-	-	210	130	-	253	340	486	104	30	
SHS4 50-160/11/P	50	65	100	155	180	-	-	134	-	-	-	160	-	-	210	130	-	253	340	553	104	36	
SHS4 50-200/11/P	50	65	100	155	200	-	-	134	-	-	-	160	-	-	245	130	-	310	360	553	104	49	
SHS4 50-200/15/P	50	65	100	155	200	-	-	134	-	-	-	160	-	-	245	130	-	310	360	553	104	52	
SHS4 50-250/22A/P	50	65	100	165	225	-	-	168	-	-	-	180	-	-	265	130	-	345	405	587	107	58	
SHS4 50-250/22/P	50	65	100	165	225	-	-	168	-	-	-	180	-	-	265	130	-	345	405	587	107	59	
SHS4 50-250/30/P	50	65	100	165	225	-	-	168	-	-	-	180	-	-	265	130	-	345	405	618	107	65	
SHS4 65-160/05/A	65	80	100	155	200	-	-	129	-	-	-	160	-	-	245	130	-	310	360	518	130	34	
SHS4 65-160/07/C	65	80	100	155	200	-	-	128	-	-	-	160	-	-	245	130	-	310	360	486	130	38	
SHS4 65-160/11A/P	65	80	100	155	200	-	-	134	-	-	-	160	-	-	245	130	-	310	360	553	130	46	
SHS4 65-160/11/P	65	80	100	155	200	-	-	134	-	-	-	160	-	-	245	130	-	310	360	553	130	48	
SHS4 65-160/15/P	65	80	100	155	200	-	-	134	-	-	-	160	-	-	245	130	-	310	360	553	130	51	
SHS4 65-200/15/P	65	80	100	155	225	-	-	134	-	-	-	180	-	-	245	130	-	310	405	553	130	54	
SHS4 65-200/22/P	65	80	100	165	225	-	-	168	-	-	-	180	-	-	245	130	-	310	405	587	130	71	
SHS4 65-200/30/P	65	80	100	165	225	-	-	168	-	-	-	180	-	-	245	130	-	310	405	618	130	72	
SHS4 65-250/40/P	65	80	100	165	250	-	380	168	-	-	-	200	-	-	265	130	-	345	450	663	140	97	
SHS4 65-250/55/P	65	80	100	192	250	-	435	191	-	-	-	200	-	-	265	130	-	345	450	697	140	104	
SHS4 80-160/15/P	80	100	125	155	225	-	-	134	-	-	-	180	-	-	265	130	-	345	405	578	160	59	
SHS4 80-160/22A/P	80	100	125	165	225	-	-	168	-	-	-	180	-	-	265	130	-	345	405	612	160	67	
SHS4 80-160/22/P	80	100	125	165	225	-	-	168	-	-	-	180	-	-	265	130	-	345	405	612	160	67	
SHS4 80-200/30/P	80	100	125	165	250	-	-	168	-	-	-	180	-	-	265	130	-	345	430	643	160	72	
SHS4 80-200/40/P	80	100	125	165	250	-	380	168	-	-	-	180	-	-	265	130	-	345	430	688	160	88	
SHS4 80-250/55/P	80	100	125	192	280	-	435	191	-	-	-	200	-	-	303	210	-	383	480	722	160	107	
SHS4 80-250/75/P	80	100	125	192	280	-	435	191	-	-	-	200	-	-	303	210	-	383	480	722	160	113	
SHS4 80-250/110/P	80	100	125	222	280	330	-	240	49	5	40	200	304	210	304	254	15	383	480	841	160	153	

* Motor shim on request

sh-shs4-4p50-en_e_td

**SHF SERIES (BARE SHAFT)
DIMENSIONS AND WEIGHTS AT 50 Hz**

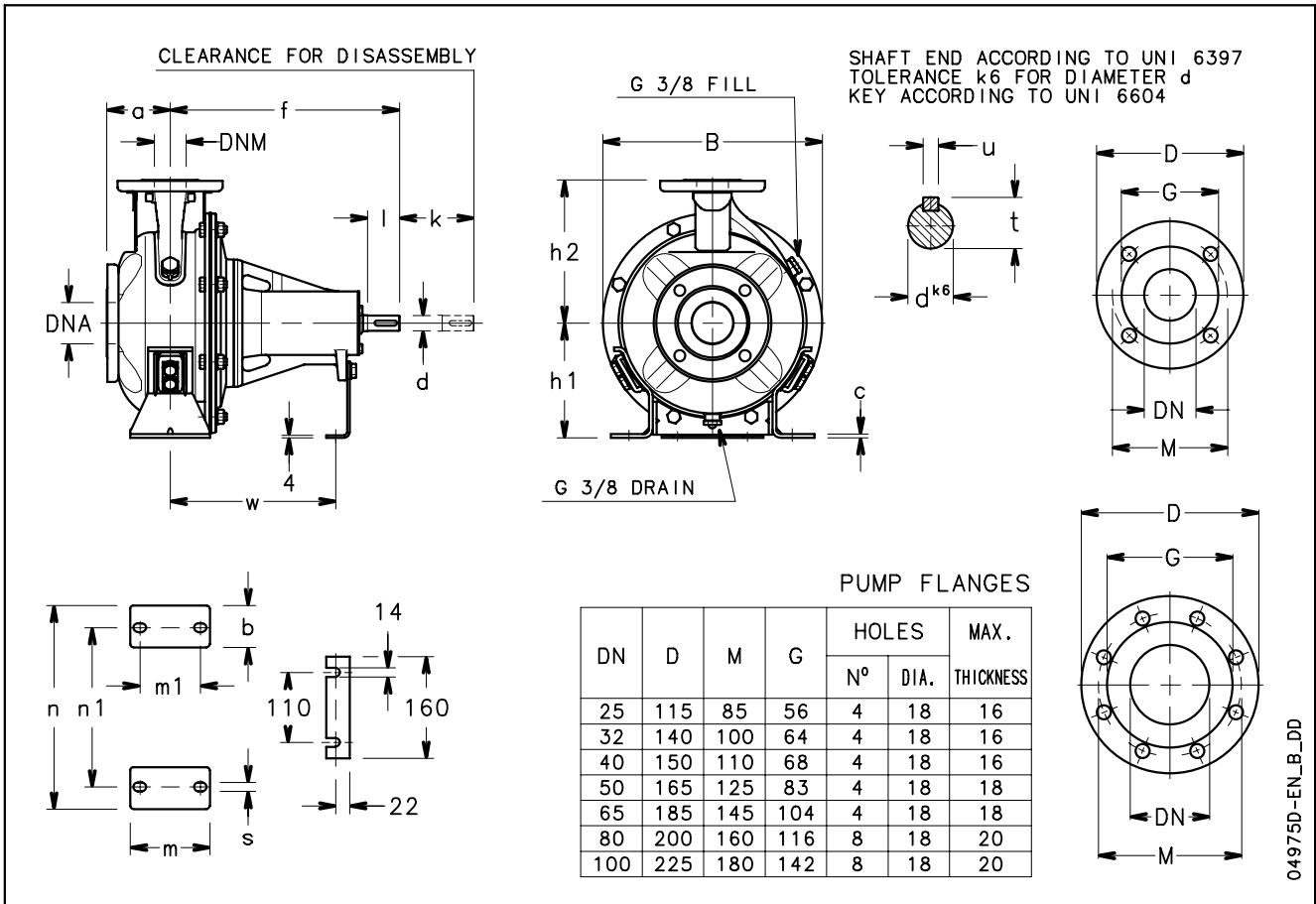

SHF SERIES (BARE SHAFT) DIMENSIONS AND WEIGHTS AT 50 Hz

PUMP TYPE	DIMENSIONS (mm)																			B	k	WEIGHT kg
	PUMP						SUPPORT							SHAFT								
	DNM	DNA	a	f	h1	h2	b	c	m	m1	n	n1	s	w	d	l	t	u				
SHF 25-125	25	50	80	360	112	140	47	3	100	70	190	140	14	260	24	50	27	8	218	98	14	
SHF 25-160	25	50	80	360	132	160	48	3	100	70	240	190	14	260	24	50	27	8	253	98	17	
SHF 25-200	25	50	80	360	160	180	47	3	100	70	240	190	14	260	24	50	27	8	284	98	20	
SHF 25-250	25	50	100	360	180	225	54	6	125	95	320	250	14	260	24	50	27	8	345	98	34	
SHF 32-125	32	50	80	360	112	140	47	3	100	70	190	140	14	260	24	50	27	8	218	98	14	
SHF 32-160	32	50	80	360	132	160	48	3	100	70	240	190	14	260	24	50	27	8	253	98	17	
SHF 32-200	32	50	80	360	160	180	47	3	100	70	240	190	14	260	24	50	27	8	284	98	20	
SHF 32-250	32	50	100	360	180	225	54	6	125	95	320	250	14	260	24	50	27	8	345	98	34	
SHF 40-125	40	65	80	360	112	140	47	3	100	70	210	160	14	260	24	50	27	8	218	100	16	
SHF 40-160	40	65	80	360	132	160	48	3	100	70	240	190	14	260	24	50	27	8	253	100	18	
SHF 40-200	40	65	100	360	160	180	50	3	100	70	265	212	14	260	24	50	27	8	284	100	20	
SHF 40-250	40	65	100	360	180	225	54	6	125	95	320	250	14	260	24	50	27	8	345	107	33	
SHF 50-125	50	65	100	360	132	160	48	3	100	70	240	190	14	260	24	50	27	8	253	104	17	
SHF 50-160	50	65	100	360	160	180	48	3	100	70	265	212	14	260	24	50	27	8	253	104	24	
SHF 50-200	50	65	100	360	160	200	40	6	100	70	265	212	14	260	24	50	27	8	310	104	30	
SHF 50-250	50	65	100	360	180	225	54	6	125	95	320	250	14	260	24	50	27	8	345	107	37	
SHF 65-160	65	80	100	360	160	200	48	6	125	95	280	212	14	260	24	50	27	8	310	130	31	
SHF 65-200	65	80	100	360	180	225	65	15	125	95	320	250	14	260	24	50	27	8	310	130	42	
SHF 65-250	65	80	100	470	200	250	80	18	160	120	360	280	18	340	32	80	35	10	345	140	55	
SHF 80-160	80	100	125	360	180	225	54	6	125	95	320	250	14	260	24	50	27	8	345	160	37	
SHF 80-200	80	100	125	470	180	250	65	15	125	95	345	280	14	340	32	80	35	10	345	160	55	
SHF 80-250	80	100	125	470	200	280	80	18	160	120	400	315	18	340	32	80	35	10	383	160	67	

sh-shf-en_c_td

**SHF SERIES
DIMENSIONS AND WEIGHTS AT 50 Hz, 2 POLES**

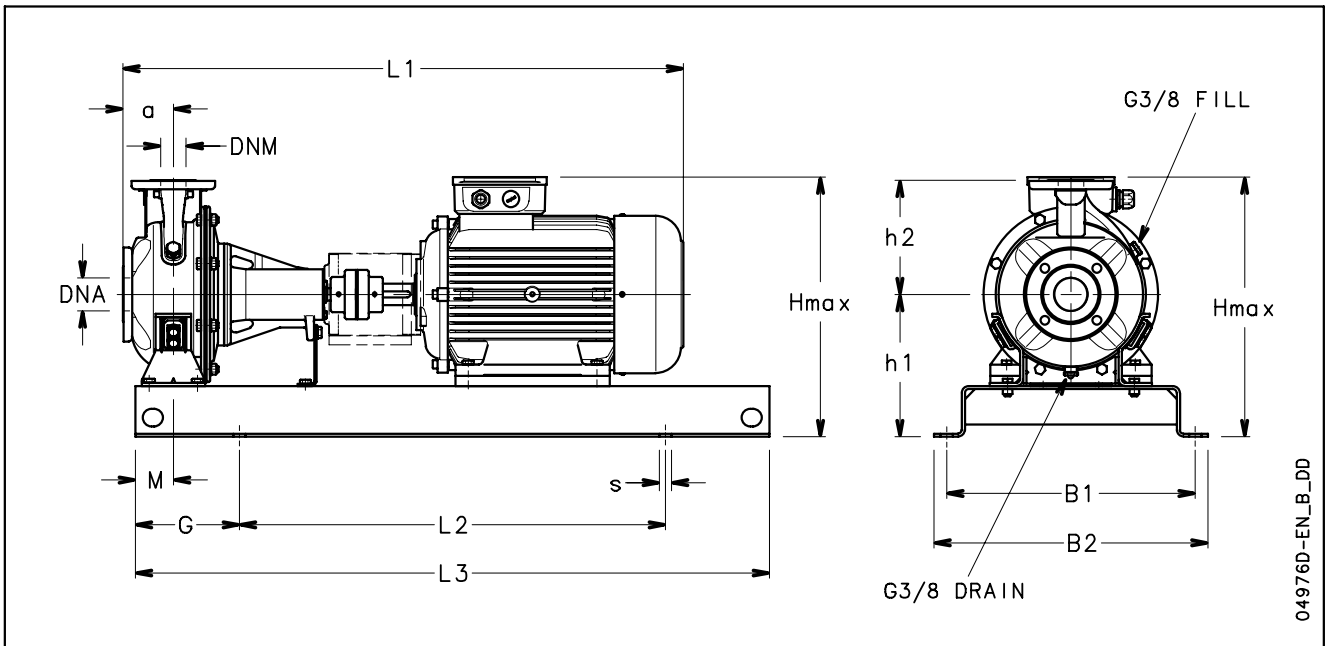

**SHF SERIES
DIMENSIONS AND WEIGHTS AT 50 Hz, 2 POLES**

PUMP TYPE	DIMENSIONS (mm)														s	WEIGHT	COUPLING
	DNM	DNA	a	B1	B2	L1	L2	L3	G	M	h1	h2	Hmax	FOR SCREWS	kg	TYPE	
SHF 25-125/07/D	25	50	80	320	360	746	540	800	130	60	212	140	352	M16	67	A2	
SHF 25-125/11/D	25	50	80	320	360	746	540	800	130	60	212	140	352	M16	69	A2	
SHF 25-160/15/P	25	50	80	350	390	791	600	900	150	60	232	160	392	M16	73	A3	
SHF 25-160/22/P	25	50	80	350	390	791	600	900	150	60	232	160	392	M16	75	A3	
SHF 25-200/30/P	25	50	80	350	390	822	600	900	150	60	260	180	440	M16	95	B1	
SHF 25-200/40/P	25	50	80	350	390	825	600	900	150	60	260	180	440	M16	97	B1	
SHF 25-250/55/P	25	50	100	440	490	910	740	1120	190	75	280	225	505	M20	130	C1	
SHF 25-250/75/P	25	50	100	440	490	910	740	1120	190	75	280	225	505	M20	134	C1	
SHF 25-250/110/P	25	50	100	490	540	1067	840	1250	205	75	280	225	520	M20	181	C2	
SHF 32-125/07/D	32	50	80	320	360	746	540	800	130	60	212	140	352	M16	67	A2	
SHF 32-125/11/D	32	50	80	320	360	746	540	800	130	60	212	140	352	M16	69	A2	
SHF 32-160/15/P	32	50	80	350	390	791	600	900	150	60	232	160	392	M16	73	A3	
SHF 32-160/22/P	32	50	80	350	390	791	600	900	150	60	232	160	392	M16	75	A3	
SHF 32-200/30/P	32	50	80	350	390	822	600	900	150	60	260	180	440	M16	95	B1	
SHF 32-200/40/P	32	50	80	350	390	825	600	900	150	60	260	180	440	M16	97	B1	
SHF 32-250/55/P	32	50	100	440	490	910	740	1120	190	75	280	225	505	M20	130	C1	
SHF 32-250/75/P	32	50	100	440	490	910	740	1120	190	75	280	225	505	M20	134	C1	
SHF 32-250/110/P	32	50	100	490	540	1067	840	1250	205	75	280	225	520	M20	181	C2	
SHF 40-125/11/D	40	65	80	350	390	746	600	900	150	60	212	140	352	M16	70	A2	
SHF 40-125/15/P	40	65	80	350	390	791	600	900	150	60	212	140	352	M16	74	A3	
SHF 40-125/22/P	40	65	80	350	390	791	600	900	150	60	212	140	352	M16	77	A3	
SHF 40-160/30/P	40	65	80	350	390	822	600	900	150	60	232	160	392	M16	92	B1	
SHF 40-160/40/P	40	65	80	350	390	825	600	900	150	60	232	160	400	M16	96	B1	
SHF 40-200/55/P	40	65	100	400	450	910	660	1000	170	60	260	180	451	M20	123	C1	
SHF 40-200/75/P	40	65	100	400	450	910	660	1000	170	60	260	180	451	M20	128	C1	
SHF 40-250/110A/P	40	65	100	490	540	1067	840	1250	205	75	280	225	520	M20	167	C2	
SHF 40-250/110/P	40	65	100	490	540	1067	840	1250	205	75	280	225	520	M20	170	C2	
SHF 40-250/150/P	40	65	100	490	540	1067	840	1250	205	75	280	225	520	M20	175	C2	
SHF 50-125/22/P	50	65	100	350	390	811	600	900	150	60	232	160	392	M16	84	A3	
SHF 50-125/30/P	50	65	100	350	390	842	600	900	150	60	232	160	392	M16	92	B1	
SHF 50-125/40/P	50	65	100	350	390	845	600	900	150	60	232	160	400	M16	95	B1	
SHF 50-160/55/P	50	65	100	400	450	910	660	1000	170	60	260	180	451	M20	120	C1	
SHF 50-160/75/P	50	65	100	400	450	910	660	1000	170	60	260	180	451	M20	122	C1	
SHF 50-200/110A/P	50	65	100	440	490	1067	740	1120	190	60	260	200	500	M20	145	C2	
SHF 50-200/110/P	50	65	100	440	490	1067	740	1120	190	60	260	200	500	M20	150	C2	
SHF 50-250/150/P	50	65	100	490	540	1067	840	1250	205	75	280	225	520	M20	165	C2	
SHF 50-250/185/P	50	65	100	490	540	1067	840	1250	205	75	280	225	520	M20	170	C2	
SHF 50-250/220/C	50	65	100	490	540	1127	840	1250	205	75	280	225	559	M20	246	D1	
SHF 65-160/40/P	65	80	100	400	450	845	660	1000	170	75	260	200	460	M20	133	B1	
SHF 65-160/55/P	65	80	100	400	450	845	660	1000	170	75	260	200	460	M20	150	C1	
SHF 65-160/75/P	65	80	100	400	450	845	660	1000	170	75	260	200	460	M20	154	C1	
SHF 65-160/110A/P	65	80	100	490	540	1067	840	1250	205	75	260	200	500	M20	162	C2	
SHF 65-160/110/P	65	80	100	490	540	1067	840	1250	205	75	260	200	500	M20	162	C2	
SHF 65-200/150/P	65	80	100	490	540	1067	840	1250	205	75	280	225	520	M20	185	C2	
SHF 65-200/185/P	65	80	100	490	540	1067	840	1250	205	75	280	225	520	M20	190	C2	
SHF 65-200/220/C	65	80	100	490	540	1127	840	1250	205	75	280	225	559	M20	274	D1	
SHF 65-250/300/C	65	80	100	550	610	1340	940	1400	230	90	310	250	627	M24	367	E1	
SHF 65-250/370/C	65	80	100	550	610	1340	940	1400	230	90	310	250	627	M24	403	E1	
SHF 80-160/110/P	80	100	125	490	540	1092	840	1250	205	75	280	225	520	M20	198	C2	
SHF 80-160/150/P	80	100	125	490	540	1092	840	1250	205	75	280	225	520	M20	209	C2	
SHF 80-160/185/P	80	100	125	490	540	1092	840	1250	205	75	280	225	520	M20	220	C2	
SHF 80-200/220/C	80	100	125	490	540	1262	840	1250	205	75	280	250	559	M20	302	D2	
SHF 80-200/300/C	80	100	125	550	610	1365	940	1400	230	75	310	250	627	M24	373	E1	
SHF 80-200/370/C	80	100	125	550	610	1365	940	1400	230	75	310	250	627	M24	402	E1	
SHF 80-250/450/C	80	100	125	550	610	1454	940	1400	230	90	365	280	749	M24	501	E1	
SHF 80-250/550/C	80	100	125	600	660	1563	1060	1600	270	90	390	280	792	M24	582	F1	
SHF 80-250/750/C	80	100	125	670	730	1670	1200	1800	300	90	420	280	892	M24	700	G1	

**SHF4 SERIES
DIMENSIONS AND WEIGHTS AT 50 Hz, 4 POLES**

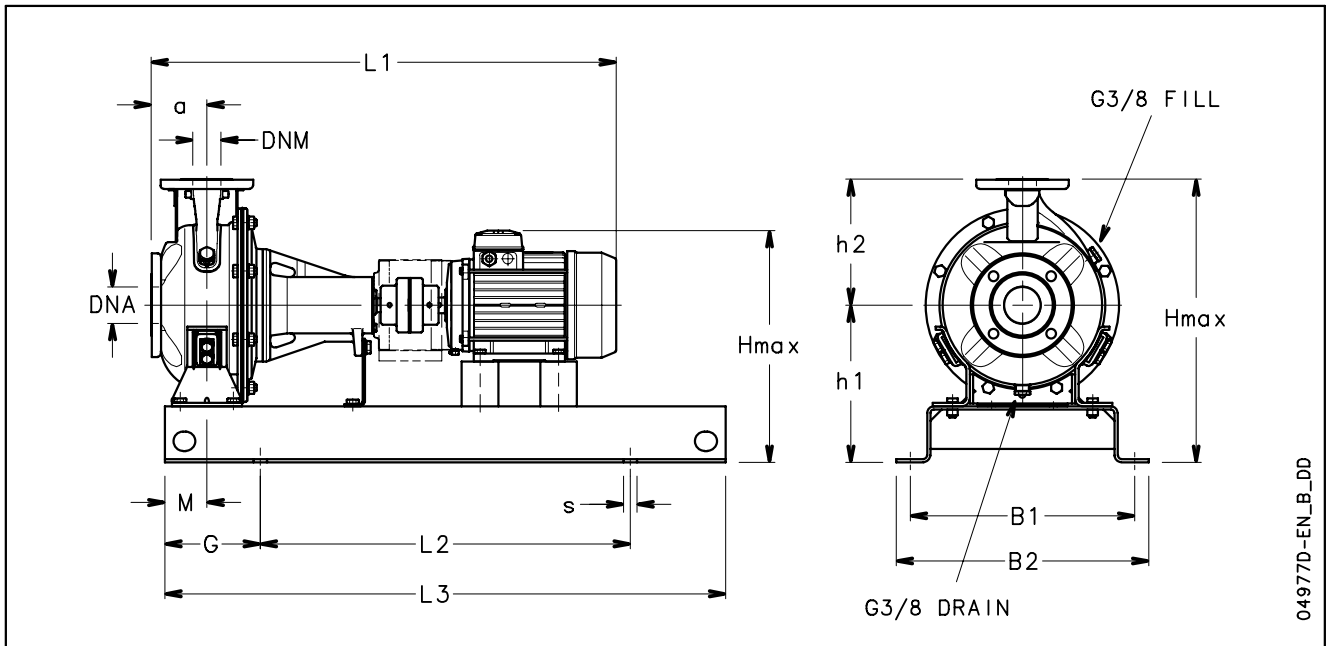

SHF4 SERIES DIMENSIONS AND WEIGHTS AT 50 Hz, 4 POLES

PUMP TYPE	DIMENSIONS (mm)														s FOR SCREWS	WEIGHT kg	COUPLING TYPE
	DNM	DNA	a	B1	B2	L1	L2	L3	G	M	h1	h2	Hmax				
SHF4 25-125/02A/A	25	50	80	320	360	704	540	800	130	60	212	140	352	M16	72	A1	
SHF4 25-125/02/A	25	50	80	320	360	704	540	800	130	60	212	140	352	M16	72	A1	
SHF4 25-160/02/A	25	50	80	320	360	704	540	800	130	60	232	160	392	M16	74	A1	
SHF4 25-160/03/A	25	50	80	320	360	704	540	800	130	60	232	160	392	M16	74	A1	
SHF4 25-200/03/A	25	50	80	320	360	704	540	800	130	60	260	180	440	M16	78	A1	
SHF4 25-200/05/A	25	50	80	320	360	746	540	800	130	60	260	180	440	M16	80	A2	
SHF4 25-250/07/C	25	50	100	400	450	734	660	1000	170	75	280	225	505	M20	98	A2	
SHF4 25-250/11/P	25	50	100	400	450	811	660	1000	170	75	280	225	505	M20	106	A3	
SHF4 25-250/15/P	25	50	100	400	450	811	660	1000	170	75	280	225	505	M20	108	A3	
SHF4 32-125/02A/A	32	50	80	320	360	704	540	800	130	60	212	140	352	M16	72	A1	
SHF4 32-125/02/A	32	50	80	320	360	704	540	800	130	60	212	140	352	M16	72	A1	
SHF4 32-160/02/A	32	50	80	320	360	704	540	800	130	60	232	160	392	M16	74	A1	
SHF4 32-160/03/A	32	50	80	320	360	704	540	800	130	60	232	160	392	M16	74	A1	
SHF4 32-200/03/A	32	50	80	320	360	704	540	800	130	60	260	180	440	M16	78	A1	
SHF4 32-200/05/A	32	50	80	320	360	746	540	800	130	60	260	180	440	M16	80	A2	
SHF4 32-250/07/C	32	50	100	400	450	734	660	1000	170	75	280	225	505	M20	98	A2	
SHF4 32-250/11/P	32	50	100	400	450	811	660	1000	170	75	280	225	505	M20	106	A3	
SHF4 32-250/15/P	32	50	100	400	450	811	660	1000	170	75	280	225	505	M20	108	A3	
SHF4 40-125/02A/A	40	65	80	320	360	704	540	800	130	60	212	140	352	M16	57	A1	
SHF4 40-125/02/A	40	65	80	320	360	704	540	800	130	60	212	140	352	M16	57	A1	
SHF4 40-125/03/A	40	65	80	320	360	704	540	800	130	60	212	140	352	M16	58	A1	
SHF4 40-160/03/A	40	65	80	320	360	704	540	800	130	60	232	160	392	M16	60	A1	
SHF4 40-160/05/A	40	65	80	320	360	746	540	800	130	60	232	160	392	M16	62	A2	
SHF4 40-200/07/C	40	65	100	350	390	734	600	900	150	60	260	180	440	M16	70	A2	
SHF4 40-200/11/P	40	65	100	350	390	811	600	900	150	60	260	180	440	M16	78	A3	
SHF4 40-250/11/P	40	65	100	400	450	811	660	1000	170	75	280	225	505	M20	105	A3	
SHF4 40-250/15/P	40	65	100	400	450	811	660	1000	170	75	280	225	505	M20	108	A3	
SHF4 40-250/22/P	40	65	100	400	450	888	660	1000	170	75	280	225	505	M20	131	B1	
SHF4 50-125/03A/A	50	65	100	320	360	724	540	800	130	60	232	160	392	M16	59	A1	
SHF4 50-125/03/A	50	65	100	320	360	724	540	800	130	60	232	160	392	M16	59	A1	
SHF4 50-125/05/A	50	65	100	320	360	766	540	800	130	60	232	160	392	M16	61	A2	
SHF4 50-160/07/C	50	65	100	350	390	734	600	900	150	60	260	180	440	M16	69	A2	
SHF4 50-160/11/P	50	65	100	350	390	811	600	900	150	60	260	180	440	M16	77	A3	
SHF4 50-200/11/P	50	65	100	350	390	811	600	900	150	60	260	200	460	M16	88	A3	
SHF4 50-200/15/P	50	65	100	350	390	811	600	900	150	60	260	200	460	M16	91	A3	
SHF4 50-250/22A/P	50	65	100	400	450	888	660	1000	170	75	280	225	505	M20	132	B1	
SHF4 50-250/22/P	50	65	100	400	450	888	660	1000	170	75	280	225	505	M20	132	B1	
SHF4 50-250/30/P	50	65	100	400	450	888	660	1000	170	75	280	225	505	M20	136	B1	
SHF4 65-160/05/A	65	80	100	350	390	766	600	900	150	75	260	200	460	M16	84	A2	
SHF4 65-160/07/C	65	80	100	350	390	734	600	900	150	75	260	200	460	M16	86	A2	
SHF4 65-160/11A/P	65	80	100	400	450	811	600	1000	170	75	260	200	460	M20	94	A3	
SHF4 65-160/11/P	65	80	100	400	450	811	660	1000	170	75	260	200	460	M20	94	A3	
SHF4 65-160/15/P	65	80	100	400	450	811	660	1000	170	75	260	200	460	M20	97	A3	
SHF4 65-200/15/P	65	80	100	400	450	811	660	1000	170	75	280	225	505	M20	109	A3	
SHF4 65-200/22/P	65	80	100	440	490	888	740	1120	190	75	280	225	505	M20	133	B1	
SHF4 65-200/30/P	65	80	100	440	490	888	740	1120	190	75	280	225	505	M20	137	B1	
SHF4 65-250/40/P	65	80	100	440	490	1031	740	1120	190	90	310	250	550	M20	178	C3	
SHF4 65-250/55/P	65	80	100	440	490	1058	740	1120	190	90	310	250	550	M20	193	C4	
SHF4 80-160/15/P	80	100	125	400	450	836	660	1000	170	75	280	225	505	M20	127	A3	
SHF4 80-160/22A/P	80	100	125	440	490	913	740	1120	190	75	280	225	505	M20	143	B1	
SHF4 80-160/22/P	80	100	125	440	490	913	740	1120	190	75	280	225	505	M20	143	B1	
SHF4 80-200/30/P	80	100	125	440	490	1023	740	1120	190	75	280	250	530	M20	162	C3	
SHF4 80-200/40/P	80	100	125	440	490	1056	740	1120	190	75	280	250	530	M20	171	C3	
SHF4 80-250/55/P	80	100	125	490	540	1083	840	1250	205	90	310	280	590	M20	194	C4	
SHF4 80-250/75/P	80	100	125	490	540	1083	840	1250	205	90	310	280	590	M20	198	C4	
SHF4 80-250/110/P	80	100	125	490	540	1202	840	1250	205	90	310	280	590	M20	256	C5	

**SHF..SC SERIES
DIMENSIONS AND WEIGHTS AT 50 Hz, 2 POLES**

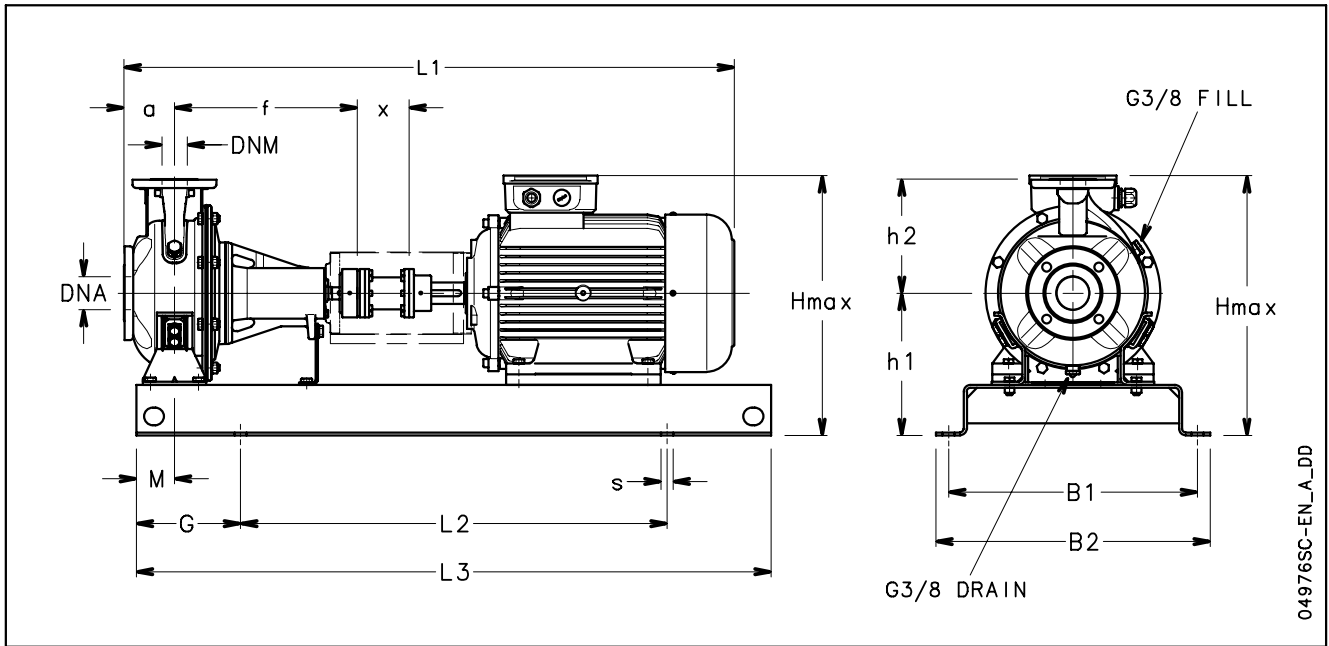

SHF..SC SERIES DIMENSIONS AND WEIGHTS AT 50 Hz, 2 POLES

PUMP TYPE	DIMENSIONS (mm)															s FOR SCREWS	WEIGHT kg	COUPLING TYPE
	DNM	DNA	a	B1	B2	L1	L2	L3	G	M	h1	h2	Hmax	f	x			
SHF 32-125/07/D SC	32	50	80	320	360	845	540	800	130	60	212	140	352	360	100	M16	69	A2S
SHF 32-125/11/D SC	32	50	80	320	360	845	540	800	130	60	212	140	352	360	100	M16	71	A2S
SHF 32-160/15/P SC	32	50	80	350	390	889	600	900	150	60	232	160	392	360	100	M16	75	A3S
SHF 32-160/22/P SC	32	50	80	350	390	889	600	900	150	60	232	160	392	360	100	M16	77	A3S
SHF 32-200/30/P SC	32	50	80	350	390	920	600	900	150	60	260	180	440	360	100	M16	97	B1S
SHF 32-200/40/P SC	32	50	80	350	390	923	600	900	150	60	260	180	440	360	100	M16	99	B1S
SHF 32-250/55/P SC	32	50	100	440	490	1007	740	1120	190	75	280	225	505	360	100	M20	132	C1S
SHF 32-250/75/P SC	32	50	100	440	490	1007	740	1120	190	75	280	225	505	360	100	M20	136	C1S
SHF 32-250/110/P SC	32	50	100	490	540	1164	840	1250	205	75	280	225	520	360	100	M20	183	C2S
SHF 40-125/11/D SC	40	65	80	350	390	845	600	900	150	60	212	140	352	360	100	M16	72	A2S
SHF 40-125/15/P SC	40	65	80	350	390	889	600	900	150	60	212	140	352	360	100	M16	76	A3S
SHF 40-125/22/P SC	40	65	80	350	390	889	600	900	150	60	212	140	352	360	100	M16	79	A3S
SHF 40-160/30/P SC	40	65	80	350	390	920	600	900	150	60	232	160	392	360	100	M16	94	B1S
SHF 40-160/40/P SC	40	65	80	350	390	923	600	900	150	60	232	160	400	360	100	M16	98	B1S
SHF 40-200/55/P SC	40	65	100	400	450	1007	660	1000	170	60	260	180	451	360	100	M20	125	C1S
SHF 40-200/75/P SC	40	65	100	400	450	1007	660	1000	170	60	260	180	451	360	100	M20	130	C1S
SHF 40-250/110A/P SC	40	65	100	490	540	1164	840	1250	205	75	280	225	520	360	100	M20	169	C2S
SHF 40-250/110/P SC	40	65	100	490	540	1164	840	1250	205	75	280	225	520	360	100	M20	172	C2S
SHF 40-250/150/P SC	40	65	100	490	540	1164	840	1250	205	75	280	225	520	360	100	M20	177	C2S
SHF 50-125/22/P SC	50	65	100	350	390	909	600	900	150	60	232	160	392	360	100	M16	86	A3S
SHF 50-125/30/P SC	50	65	100	350	390	940	600	900	150	60	232	160	392	360	100	M16	94	B1S
SHF 50-125/40/P SC	50	65	100	350	390	943	600	900	150	60	232	160	400	360	100	M16	97	B1S
SHF 50-160/55/P SC	50	65	100	400	450	1007	660	1000	170	60	260	180	451	360	100	M20	122	C1S
SHF 50-160/75/P SC	50	65	100	400	450	1007	660	1000	170	60	260	180	451	360	100	M20	124	C1S
SHF 50-200/110A/P SC	50	65	100	440	490	1164	740	1120	190	60	260	200	500	360	100	M20	147	C2S
SHF 50-200/110/P SC	50	65	100	440	490	1164	740	1120	190	60	260	200	500	360	100	M20	152	C2S
SHF 50-250/150/P SC	50	65	100	490	540	1164	840	1250	205	75	280	225	520	360	100	M20	167	C2S
SHF 50-250/185/P SC	50	65	100	490	540	1164	840	1250	205	75	280	225	520	360	100	M20	172	C2S
SHF 50-250/220/C SC	50	65	100	490	540	1224	840	1250	205	75	280	225	559	360	100	M20	248	D1S
SHF 65-160/40/P SC	65	80	100	400	450	943	660	1000	170	75	260	200	460	360	100	M20	135	B1S
SHF 65-160/55/P SC	65	80	100	400	450	1007	660	1000	170	75	260	200	460	360	100	M20	152	C1S
SHF 65-160/75/P SC	65	80	100	400	450	1007	660	1000	170	75	260	200	460	360	100	M20	156	C1S
SHF 65-160/110A/P SC	65	80	100	490	540	1164	840	1250	205	75	260	200	500	360	100	M20	164	C2S
SHF 65-160/110/P SC	65	80	100	490	540	1164	840	1250	205	75	260	200	500	360	100	M20	164	C2S
SHF 65-200/150/P SC	65	80	100	490	540	1164	840	1250	205	75	280	225	520	360	100	M20	187	C2S
SHF 65-200/185/P SC	65	80	100	490	540	1164	840	1250	205	75	280	225	520	360	100	M20	192	C2S
SHF 65-200/220/C SC	65	80	100	490	540	1224	840	1250	205	75	280	225	559	360	100	M20	276	D1S
SHF 65-250/300/C SC	65	80	100	550	610	1477	940	1400	230	90	310	250	627	470	140	M24	370	E1S
SHF 65-250/370/C SC	65	80	100	550	610	1477	940	1400	230	90	310	250	627	470	140	M24	406	E1S
SHF 80-160/110/P SC	80	100	125	490	540	1189	840	1250	205	75	280	225	520	360	100	M20	200	C2S
SHF 80-160/150/P SC	80	100	125	490	540	1189	840	1250	205	75	280	225	520	360	100	M20	211	C2S
SHF 80-160/185/P SC	80	100	125	490	540	1189	840	1250	205	75	280	225	520	360	100	M20	222	C2S
SHF 80-200/220/C SC	80	100	125	490	540	1359	840	1250	205	75	280	250	559	470	100	M20	304	D2S
SHF 80-200/300/C SC	80	100	125	550	610	1502	940	1400	230	75	310	250	627	470	140	M24	376	E1S
SHF 80-200/370/C SC	80	100	125	550	610	1502	940	1400	230	75	310	250	627	470	140	M24	405	E1S
SHF 80-250/450/C SC	80	100	125	550	610	1591	940	1400	230	90	365	280	749	470	140	M24	504	E1S
SHF 80-250/550/C SC	80	100	125	600	660	1700	1060	1600	270	90	390	280	792	470	140	M24	587	F1S
SHF 80-250/750/C SC	80	100	125	670	730	1807	1200	1800	300	90	420	280	892	470	140	M24	706	G1S

sh-shf-sc-2p50-en_e_td

ACCESSORIES

Dimensions of counter-flanges	98
Dimensions of flexible joints	99
Shims for pump/motor feet	101

DIMENSIONS OF ROUND THREADED COUNTERFLANGES ACCORDING TO EN 1092-1

DN	ø C	DIMENSIONS (mm)				HOLES		PN
		ø A	B	ø D	H	ø F	N°	
25	Rp 1	85	10	115	16	14	4	16
32	Rp 1¼	100	13	140	16	18	4	16
40	Rp 1½	110	14	150	19	18	4	16
50	Rp 2	125	16	165	24	18	4	16
65	Rp 2½	145	16	185	23	18	4	16
80	Rp 3	160	17	200	27	18	8	16
100	Rp 4	180	18	220	31	18	8	16

sh-ctf-tonde-f-en_b_td

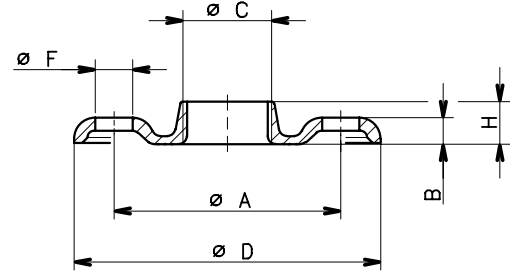

04430_B_DD

DIMENSIONS OF ROUND WELD-ON COUNTERFLANGES ACCORDING TO EN 1092-1

DN	ø C	DIMENSIONS (mm)			HOLES		PN
		ø A	B	ø D	ø F	N°	
65	77	145	18	185	18	4	16
80	90	160	20	200	18	8	16
100	115,5	180	22	220	18	8	16

sh-ctf-tonde-s-en_b_td

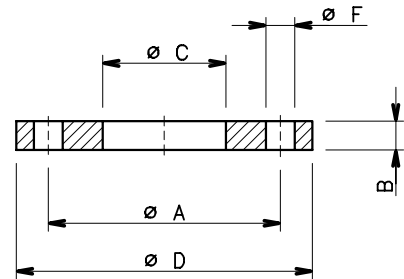

04431_A_DD

FLEXIBLE COUPLING DIMENSIONS

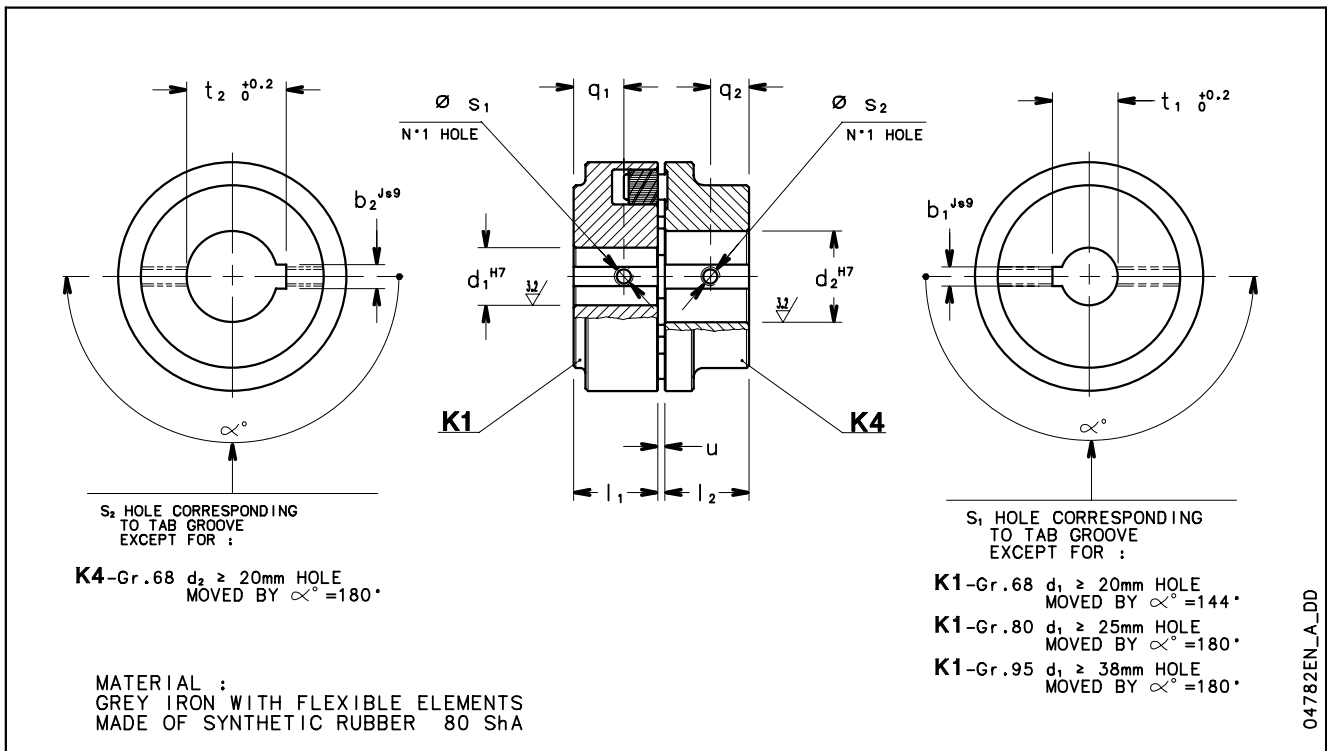

REF.	DENOMINATION	DIMENSIONS (mm)												
		K1 PUMP-SIDE HALF COUPLING						K4 MOTOR-SIDE HALF COUPLING						
		SIZE x d_1 x d_2	d_1^{H7}	l_1	b_1^{js9}	$t_1^{+0.2}$	s_1	q_1	u	d_2^{H7}	l_2	b_2^{js9}	$t_2^{+0.2}$	s_2
A1	B 68 x 24 x 14	24	20	8	27,3	M6	10	2 ÷ 4	14	20	5	16,3	M6	8
A2	B 68 x 24 x 19	24	20	8	27,3	M6	10	2 ÷ 4	19	20	6	21,8	M6	8
A3	B 68 x 24 x 24	24	20	8	27,3	M6	10	2 ÷ 4	24	20	8	27,3	M6	8
B1	B 80 x 24 x 28	24	30	8	27,3	M6	19	2 ÷ 4	28	30	8	31,3	M6	12
C1	B 95 x 24 x 38	24	35	8	27,3	M6	20	2 ÷ 4	38	35	10	41,3	M6	15
C2	B 95 x 24 x 42	24	35	8	27,3	M6	20	2 ÷ 4	42	35	12	45,3	M6	15
C3	B 95 x 32 x 28	32	35	10	35,3	M6	20	2 ÷ 4	28	35	8	31,3	M6	15
C4	B 95 x 32 x 38	32	35	10	35,3	M6	20	2 ÷ 4	38	35	10	41,3	M6	15
C5	B 95 x 32 x 42	32	35	10	35,3	M6	20	2 ÷ 4	42	35	12	45,3	M6	15
D1	B 110 x 24 x 48	24	40	8	27,3	M6	22	2 ÷ 4	48	40	14	51,8	M6	18
D2	B 110 x 32 x 48	32	40	10	35,3	M6	22	2 ÷ 4	48	40	14	51,8	M6	18
E1	B 125 x 32 x 55	32	50	10	35,3	M8	30	2 ÷ 4	55	50	16	59,3	M8	20
F1	B 140 x 32 x 60	32	55	10	35,3	M8	13	2 ÷ 4	60	55	18	64,4	M8	22
G1	B 160 x 32 x 65	32	60	10	35,3	M10	13	2 ÷ 6	65	60	18	69,4	M10	25

N.B.: Non-ATEX version.

shf-giunto-elastico-en_c_td

SPACER COUPLING DIMENSIONS

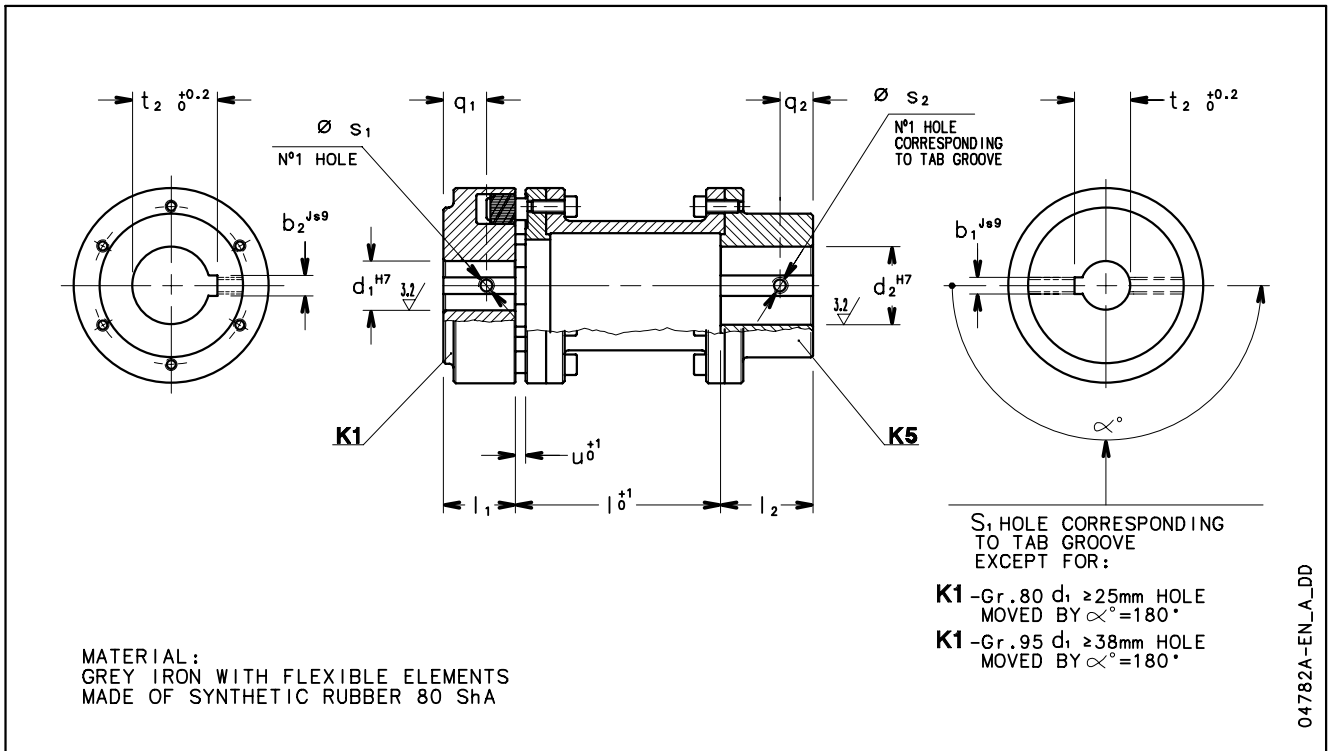

REF.	DENOMINATION	DIMENSIONS (mm)													
		K1							K5						
		PUMP-SIDE HALF COUPLING							MOTOR-SIDE HALF COUPLING						
SIXE x l x d ₁ x d ₂	l_0^{+1}	d_1^{H7}	l_1	b_1^{js9}	$t_1^{+0.2}$	s_1	q_1	u	d_2^{H7}	l_2	b_2^{js9}	$t_2^{+0.2}$	s_2	q_2	
A2S	H 80-100 x 24 x 19	100	24	30	8	27,3	M6	19	5	19	45	6	21,8	M6	15
A3S	H 80-100 x 24 x 24	100	24	30	8	27,3	M6	19	5	24	45	8	27,3	M6	15
B1S	H 80-100 x 24 x 28	100	24	30	8	27,3	M6	19	5	28	45	8	31,3	M6	15
C1S	H 95-100 x 24 x 38	100	24	35	8	27,3	M6	20	5	38	45	10	41,3	M6	20
C2S	H 95-100 x 24 x 42	100	24	35	8	27,3	M6	20	5	42	45	12	45,3	M6	20
D1S	H 110-100 x 24 x 48	100	24	40	8	27,3	M6	22	5	48	50	14	51,8	M6	25
D2S	H 110-100 x 32 x 48	100	32	40	10	35,3	M6	22	5	48	50	14	51,8	M6	25
E1S	H 125-140 x 32 x 55	140	32	50	10	35,3	M8	30	5	55	50	16	59,3	M8	25
F1S	H 140-140 x 32 x 60	140	32	55	10	35,3	M8	13	5	60	65	18	64,4	M8	30
G1S	H 160-140 x 32 x 65	140	32	60	10	35,3	M10	13	6	65	70	18	69,4	M10	35

N.B.: Non-ATEX version.

sh-giunto-elastico-con-sp-en_c_td

SH SERIES SHIM FOR MOTOR FEET

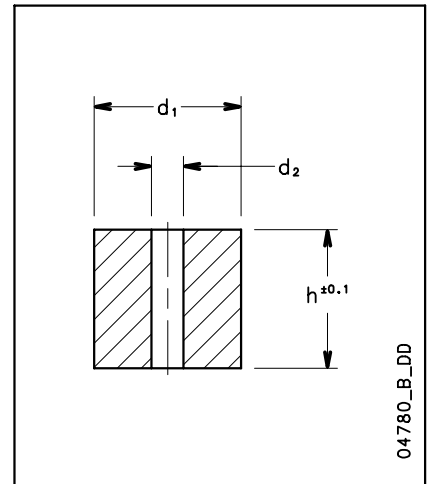
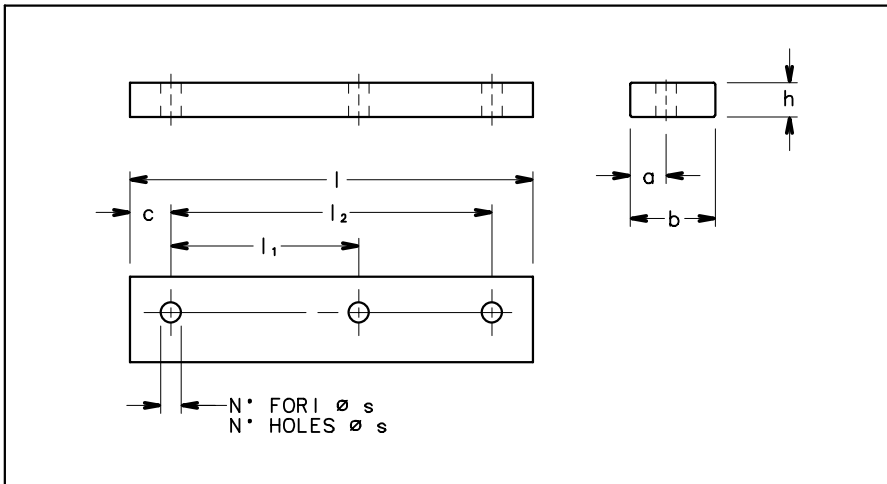

04780_B_DD

DENOMINATION		DIMENSIONS (mm)							HOLES	
b	x	h	x	l	a	l ₁	l ₂	c	N°	ø s
35	20	125			17	100	-	12,5	2	10
40	10	155			20	100	125	15	3	10
40	12	155			20	100	125	15	3	10
40	12	180			17	140	-	20	2	14
40	20	180			17	140	-	20	2	14
40	30	155			20	100	125	15	3	10
40	40	180			17	140	-	20	2	14
50	8	226			21	140	178	24	3	14
50	20	226			21	140	178	24	3	14
50	20	304			25	210	254	25	3	14
50	30	304			25	210	254	25	3	14
100	30	467			50	311	349	59	3	22

DENOMINATION		DIMENSIONS (mm)	
d ₁	x	h	d ₂
45	41	10	
45	61	10	
45	89	10	
55	52	12	
55	70	12	
55	80	12	
55	90	12	
55	100	12	
65	60	16	
65	68	16	
65	78	16	
65	80	16	
65	88	16	

sp-mot-shs-shf-en_d_td

SHIM FOR PUMP FEET (SHF)

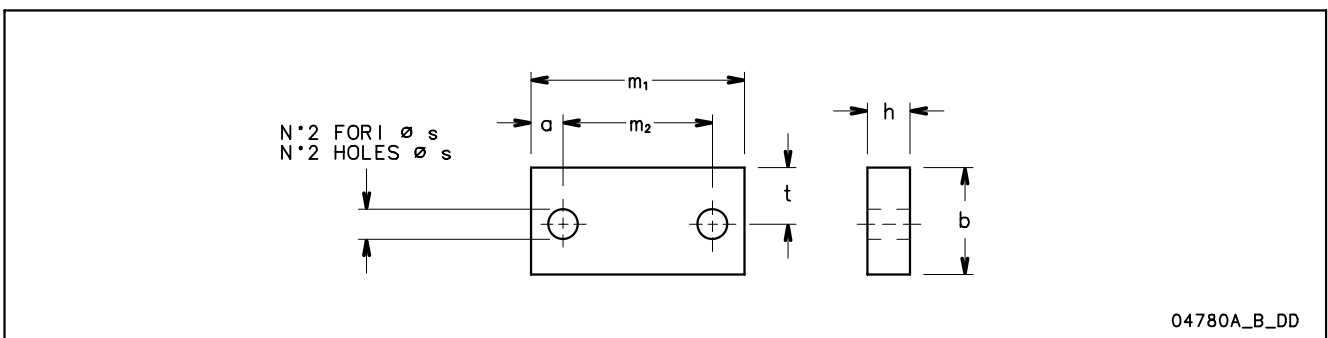

04780A_B_DD

DESIGNATION		DIMENSIONS (mm)						
b	x	h	x	m ₁	a	m ₂	ø s	t
40		10		160	25	110	14	16,5
40		20		160	25	110	14	16,5
40		25		160	25	110	14	16,5
40		30		160	25	110	14	16,5
70		20		125	15	95	14	37,5
80		10		160	20	120	18	42,5
80		25		160	20	120	18	42,5
80		30		160	20	120	18	42,5

sp-pompa-shf-en_b_td

TECHNICAL APPENDIX

TYPICAL APPLICATIONS OF SH SERIES ELECTRIC PUMPS

Water Purification:

De-ionized water
Water Treatment
Filtration
Commercial Pools

Food and Drink:

Food processing
Bottle washing
Citrus Processing
Dish washing
Brewing
Sanitary ware

Medical:

Laser cooling
Medical chillers
Sanitary equipment

Heating, Ventilating & Air Conditioning (HVAC)

Condensate return
Air scrubbers
Water re-circulation
Cooling towers
Cooling systems
Temperature control
Chillaer
Induction heating
Heat exchangers
Water heating
Booster packages

Graphics:

Film washing
Cooling of presses

Plastics:

Extrusion machines
Temperature control
Manufacture of polymers

Waste Management:

Waste treatment
Pollution control

Machine Tools:

Degreasing
Parts washing
Machine centres
Chemical treatment
Heat treatment

Vehicle Maintenance:

Car washing
Lorry or Truck wash
Wheel or tyre washing
Airplane washing

Marine:

Water on board ships
Boat design (wave machines)

Agriculture:

Irrigation
Greenhouses
Poultry Washing
Cotton humidifiers

Computers:

Washing of circuit boards

Laundry:

Commercial washing

General Industry:

Spray Booths
Light chemical transfer
Booster systems
Fire fighting

NPSH

The minimum operating values that can be reached at the pump suction end are limited by the onset of cavitation.

Cavitation is the formation of vapour-filled cavities within liquids where the pressure is locally reduced to a critical value, or where the local pressure is equal to, or just below the vapour pressure of the liquid.

The vapour-filled cavities flow with the current and when they reach a higher pressure area the vapour contained in the cavities condenses. The cavities collide, generating pressure waves that are transmitted to the walls. These, being subjected to stress cycles, gradually become deformed and yield due to fatigue. This phenomenon, characterized by a metallic noise produced by the hammering on the pipe walls, is called incipient cavitation.

The damage caused by cavitation may be magnified by electrochemical corrosion and a local rise in temperature due to the plastic deformation of the walls. The materials that offer the highest resistance to heat and corrosion are alloy steels, especially austenitic steel. The conditions that trigger cavitation may be assessed by calculating the total net suction head, referred to in technical literature with the acronym NPSH (Net Positive Suction Head).

The NPSH represents the total energy (expressed in m.) of the liquid measured at suction under conditions of incipient cavitation, excluding the vapour pressure (expressed in m.) that the liquid has at the pump inlet.

To find the static height h_z at which to install the machine under safe conditions, the following formula must be verified:

$$h_p + h_z \geq (\text{NPSH}_r + 0.5) + h_f + h_{pv} \quad \textcircled{1}$$

where:

- h_p** is the absolute pressure applied to the free liquid surface in the suction tank, expressed in m. of liquid; h_p is the quotient between the barometric pressure and the specific weight of the liquid.
- h_z** is the suction lift between the pump axis and the free liquid surface in the suction tank, expressed in m.; h_z is negative when the liquid level is lower than the pump axis.
- h_f** is the flow resistance in the suction line and its accessories, such as: fittings, foot valve, gate valve, elbows, etc.
- h_{pv}** is the vapour pressure of the liquid at the operating temperature, expressed in m. of liquid. h_{pv} is the quotient between the Pv vapour pressure and the liquid's specific weight.
- 0,5** is the safety factor.

The maximum possible suction head for installation depends on the value of the atmospheric pressure (i.e. the elevation above sea level at which the pump is installed) and the temperature of the liquid.

To help the user, with reference to water temperature (4° C) and to the elevation above sea level, the following tables show the drop in hydraulic pressure head in relation to the elevation above sea level, and the suction loss in relation to temperature.

Water temperature (°C)	20	40	60	80	90	110	120
Suction loss (m)	0,2	0,7	2,0	5,0	7,4	15,4	21,5

Elevation above sea level (m)	500	1000	1500	2000	2500	3000
Suction loss (m)	0,55	1,1	1,65	2,2	2,75	3,3

Friction loss is shown in the tables at pages 107-108 of this catalogue. To reduce it to a minimum, especially in cases of high suction head (over 4-5 m.) or within the operating limits with high flow rates, we recommend using a suction line having a larger diameter than that of the pump's suction port. It is always a good idea to position the pump as close as possible to the liquid to be pumped.

Make the following calculation:

Liquid: water at ~15°C $\gamma = 1 \text{ kg/dm}^3$

Flow rate required: 30 m³/h

Head for required delivery: 43 m.

Suction lift: 3,5 m.

The selection is an FHE 40-200/75 pump whose NPSH required value is, at 30 m³/h, di 2,5 m.

For water at 15 °C

$$h_p = P_a / \gamma = 10,33\text{m}, h_{pv} = P_v / \gamma = 0,174\text{m} (0,01701 \text{ bar})$$

The H_f flow resistance in the suction line with foot valves is ~ 1,2 m.

By substituting the parameters in formula $\textcircled{1}$ with the numeric values above, we have:

$$10,33 + (-3,5) \geq (2,5 + 0,5) + 1,2 + 0,17$$

from which we have: 6,8 > 4,4

The relation is therefore verified.

VAPOUR PRESSURE
VAPOUR PRESSURE ps AND ρ DENSITY OF WATER TABLE

t	T	ps	ρ	t	T	ps	ρ	t	T	ps	ρ
°C	K	bar	kg/dm ³	°C	K	bar	kg/dm ³	°C	K	bar	kg/dm ³
0	273,15	0,00611	0,9998	55	328,15	0,15741	0,9857	120	393,15	1,9854	0,9429
1	274,15	0,00657	0,9999	56	329,15	0,16511	0,9852	122	395,15	2,1145	0,9412
2	275,15	0,00706	0,9999	57	330,15	0,17313	0,9846	124	397,15	2,2504	0,9396
3	276,15	0,00758	0,9999	58	331,15	0,18147	0,9842	126	399,15	2,3933	0,9379
4	277,15	0,00813	1,0000	59	332,15	0,19016	0,9837	128	401,15	2,5435	0,9362
5	278,15	0,00872	1,0000	60	333,15	0,1992	0,9832	130	403,15	2,7013	0,9346
6	279,15	0,00935	1,0000	61	334,15	0,2086	0,9826	132	405,15	2,867	0,9328
7	280,15	0,01001	0,9999	62	335,15	0,2184	0,9821	134	407,15	3,041	0,9311
8	281,15	0,01072	0,9999	63	336,15	0,2286	0,9816	136	409,15	3,223	0,9294
9	282,15	0,01147	0,9998	64	337,15	0,2391	0,9811	138	411,15	3,414	0,9276
10	283,15	0,01227	0,9997	65	338,15	0,2501	0,9805	140	413,15	3,614	0,9258
11	284,15	0,01312	0,9997	66	339,15	0,2615	0,9799	145	418,15	4,155	0,9214
12	285,15	0,01401	0,9996	67	340,15	0,2733	0,9793	155	428,15	5,433	0,9121
13	286,15	0,01497	0,9994	68	341,15	0,2856	0,9788	160	433,15	6,181	0,9073
14	287,15	0,01597	0,9993	69	342,15	0,2984	0,9782	165	438,15	7,008	0,9024
15	288,15	0,01704	0,9992	70	343,15	0,3116	0,9777	170	433,15	7,920	0,8973
16	289,15	0,01817	0,9990	71	344,15	0,3253	0,9770	175	448,15	8,924	0,8921
17	290,15	0,01936	0,9988	72	345,15	0,3396	0,9765	180	453,15	10,027	0,8869
18	291,15	0,02062	0,9987	73	346,15	0,3543	0,9760	185	458,15	11,233	0,8815
19	292,15	0,02196	0,9985	74	347,15	0,3696	0,9753	190	463,15	12,551	0,8760
20	293,15	0,02337	0,9983	75	348,15	0,3855	0,9748	195	468,15	13,987	0,8704
21	294,15	0,24850	0,9981	76	349,15	0,4019	0,9741	200	473,15	15,550	0,8647
22	295,15	0,02642	0,9978	77	350,15	0,4189	0,9735	205	478,15	17,243	0,8588
23	296,15	0,02808	0,9976	78	351,15	0,4365	0,9729	210	483,15	19,077	0,8528
24	297,15	0,02982	0,9974	79	352,15	0,4547	0,9723	215	488,15	21,060	0,8467
25	298,15	0,03166	0,9971	80	353,15	0,4736	0,9716	220	493,15	23,198	0,8403
26	299,15	0,03360	0,9968	81	354,15	0,4931	0,9710	225	498,15	25,501	0,8339
27	300,15	0,03564	0,9966	82	355,15	0,5133	0,9704	230	503,15	27,976	0,8273
28	301,15	0,03778	0,9963	83	356,15	0,5342	0,9697	235	508,15	30,632	0,8205
29	302,15	0,04004	0,9960	84	357,15	0,5557	0,9691	240	513,15	33,478	0,8136
30	303,15	0,04241	0,9957	85	358,15	0,5780	0,9684	245	518,15	36,523	0,8065
31	304,15	0,04491	0,9954	86	359,15	0,6011	0,9678	250	523,15	39,776	0,7992
32	305,15	0,04753	0,9951	87	360,15	0,6249	0,9671	255	528,15	43,246	0,7916
33	306,15	0,05029	0,9947	88	361,15	0,6495	0,9665	260	533,15	46,943	0,7839
34	307,15	0,05318	0,9944	89	362,15	0,6749	0,9658	265	538,15	50,877	0,7759
35	308,15	0,05622	0,9940	90	363,15	0,7011	0,9652	270	543,15	55,058	0,7678
36	309,15	0,05940	0,9937	91	364,15	0,7281	0,9644	275	548,15	59,496	0,7593
37	310,15	0,06274	0,9933	92	365,15	0,7561	0,9638	280	553,15	64,202	0,7505
38	311,15	0,06624	0,9930	93	366,15	0,7849	0,9630	285	558,15	69,186	0,7415
39	312,15	0,06991	0,9927	94	367,15	0,8146	0,9624	290	563,15	74,461	0,7321
40	313,15	0,07375	0,9923	95	368,15	0,8453	0,9616	295	568,15	80,037	0,7223
41	314,15	0,07777	0,9919	96	369,15	0,8769	0,9610	300	573,15	85,927	0,7122
42	315,15	0,08198	0,9915	97	370,15	0,9094	0,9602	305	578,15	92,144	0,7017
43	316,15	0,09639	0,9911	98	371,15	0,9430	0,9596	310	583,15	98,70	0,6906
44	317,15	0,09100	0,9907	99	372,15	0,9776	0,9586	315	588,15	105,61	0,6791
45	318,15	0,09582	0,9902	100	373,15	1,0133	0,9581	320	593,15	112,89	0,6669
46	319,15	0,10086	0,9898	102	375,15	1,0878	0,9567	325	598,15	120,56	0,6541
47	320,15	0,10612	0,9894	104	377,15	1,1668	0,9552	330	603,15	128,63	0,6404
48	321,15	0,11162	0,9889	106	379,15	1,2504	0,9537	340	613,15	146,05	0,6102
49	322,15	0,11736	0,9884	108	381,15	1,3390	0,9522	350	623,15	165,35	0,5743
50	323,15	0,12335	0,9880	110	383,15	1,4327	0,9507	360	633,15	186,75	0,5275
51	324,15	0,12961	0,9876	112	385,15	1,5316	0,9491	370	643,15	210,54	0,4518
52	325,15	0,13613	0,9871	114	387,15	1,6362	0,9476	374,15	647,30	221,20	0,3154
53	326,15	0,14293	0,9862	116	389,15	1,7465	0,9460				
54	327,15	0,15002	0,9862	118	391,15	1,8628	0,9445				

FLOW RESISTANCE TABLE OF FLOW RESISTANCE IN BENDS, VALVES AND GATES

The flow resistance is calculated using the equivalent pipeline length method according to the table below:

ACCESSORY TYPE	DN											
	25	32	40	50	65	80	100	125	150	200	250	300
	Equivalent pipeline length (m)											
45° bend	0,2	0,2	0,4	0,4	0,6	0,6	0,9	1,1	1,5	1,9	2,4	2,8
90° bend	0,4	0,6	0,9	1,1	1,3	1,5	2,1	2,6	3,0	3,9	4,7	5,8
90° smooth bend	0,4	0,4	0,4	0,6	0,9	1,1	1,3	1,7	1,9	2,8	3,4	3,9
Union tee or cross	1,1	1,3	1,7	2,1	2,6	3,2	4,3	5,3	6,4	7,5	10,7	12,8
Gate	-	-	-	0,2	0,2	0,2	0,4	0,4	0,6	0,9	1,1	1,3
Non return valve	1,1	1,5	1,9	2,4	3,0	3,4	4,7	5,9	7,4	9,6	11,8	13,9

G-a-pcv-en_a_th

The table is valid for the Hazen Williams coefficient $C=100$ (cast iron pipework);

for steel pipework, multiply the values by 1,41;

for stainless steel, copper and coated cast iron pipework, multiply the values by 1,85;

When the **equivalent pipeline length** has been determined, the flow resistance is obtained from the table of flow resistance.

The values given are guideline values which are bound to vary slightly according to the model, especially for gate valves and non-return valves, for which it is a good idea to check the values supplied by manufacturers.

VOLUMETRIC CAPACITY

Litres per minute l/min	Cubic metres per hour m ³ /h	Cubic feet per hour ft ³ /h	Cubic feet per minute ft ³ /min	Imp. gal. per minute Imp. gal./min	US gal. per minute Us gal./min
1,000	0,0600	2,1189	0,0353	0,2200	0,2642
16,6667	1,000	35,3147	0,5886	3,6662	4,4029
0,4719	0,0283	1,000	0,0167	0,1038	0,1247
28,3168	1,6990	60,0000	1,000	6,2288	7,4805
4,5461	0,2728	9,6326	0,1605	1,000	1,2009
3,7854	0,2271	8,0208	0,1337	0,8327	1,000

PRESSURE AND HEAD

Newton per square metre N/m ²	kilo Pascal kPa	bar bar	Pound force per square inch psi	metre of water m H ₂ O	millimetre of mercury mm Hg
1,000	0,0010	1 x 10 ⁻⁵	1.45 x 10 ⁻⁴	1.02 x 10 ⁻⁴	0,0075
1000,0000	1,000	0,0100	0,1450	0,1020	7,5006
1 x 10 ⁵	100,0000	1,000	14,5038	10,1972	750,0638
6894,7570	6,8948	0,0689	1,000	0,7031	51,7151
9806,6500	9,8067	0,0981	1,4223	1,000	73,5561
133,3220	0,1333	0,0013	0,0193	0,0136	1,000

LENGTH

millimetre mm	centimetre cm	metre m	inch in	foot ft	yard yd
1,000	0,1000	0,0010	0,0394	0,0033	0,0011
10,0000	1,000	0,0100	0,3937	0,0328	0,0109
1000,0000	100,0000	1,000	39,3701	3,2808	1,0936
25,4000	2,5400	0,0254	1,000	0,0833	0,0278
304,8000	30,4800	0,3048	12,0000	1,000	0,3333
914,4000	91,4400	0,9144	36,0000	3,0000	1,000

VOLUME

cubic metre m ³	litre litro	millilitre ml	imp. Gallon imp. gal.	US gallon US gal.	cubic foot ft ³
1,000	1000,0000	1 x 10 ⁶	219,9694	264,1720	35,3147
0,0010	1,000	1000,0000	0,2200	0,2642	0,0353
1 x 10 ⁻⁶	0,0010	1,000	2.2 x 10 ⁻⁴	2.642 x 10 ⁻⁴	3.53 x 10 ⁻⁵
0,0045	4,5461	4546,0870	1,000	1,2009	0,1605
0,0038	3,7854	3785,4120	0,8327	1,000	0,1337
0,0283	28,3168	28316,8466	6,2288	7,4805	1,000

G-at_pp-en_a_sc

FURTHER PRODUCT SELECTION AND DOCUMENTATION

Xylect™

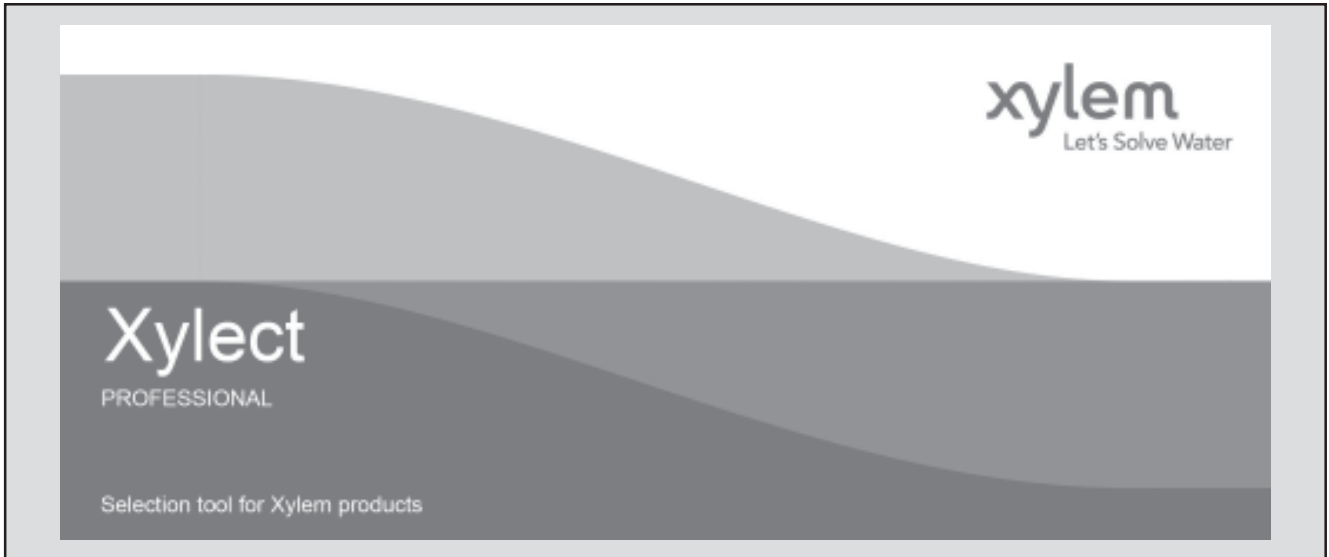

Xylect™ is pump solution selection software with an extensive online database of product information across the entire Lowara, and Vogel range of pumps and related products, with multiple search options and helpful project management facilities. The system holds up-to-date product information on thousands of products and accessories.

The possibility to search by applications and the detailed information output given makes it easy to make the optimal selection without having detailed knowledge about the Lowara and Vogel products.

The search can be made by:

- Application
- Product type
- Duty point

Xylect™ gives a detailed output:

- List with search results
- Performance curves (flow, head, power, efficiency, NPSH)
- Motor data
- Dimensional drawings
- Options
- Data sheet printouts
- Document downloads incl dxf files

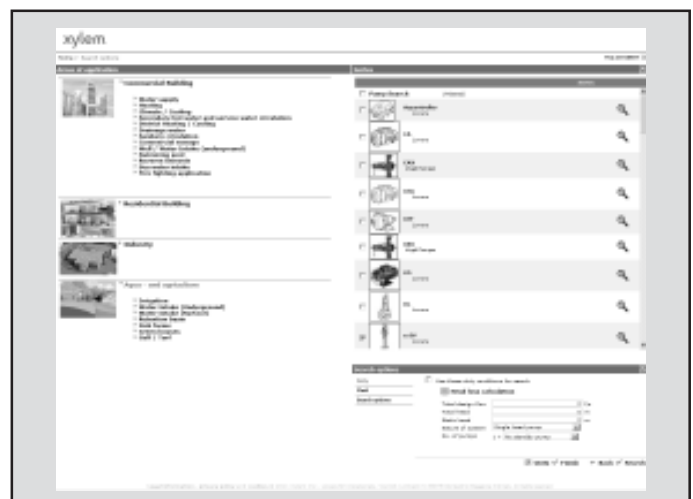

The search by application guides users not familiar with the product range to the right choice.

FURTHER PRODUCT SELECTION AND DOCUMENTATION

Xylect™

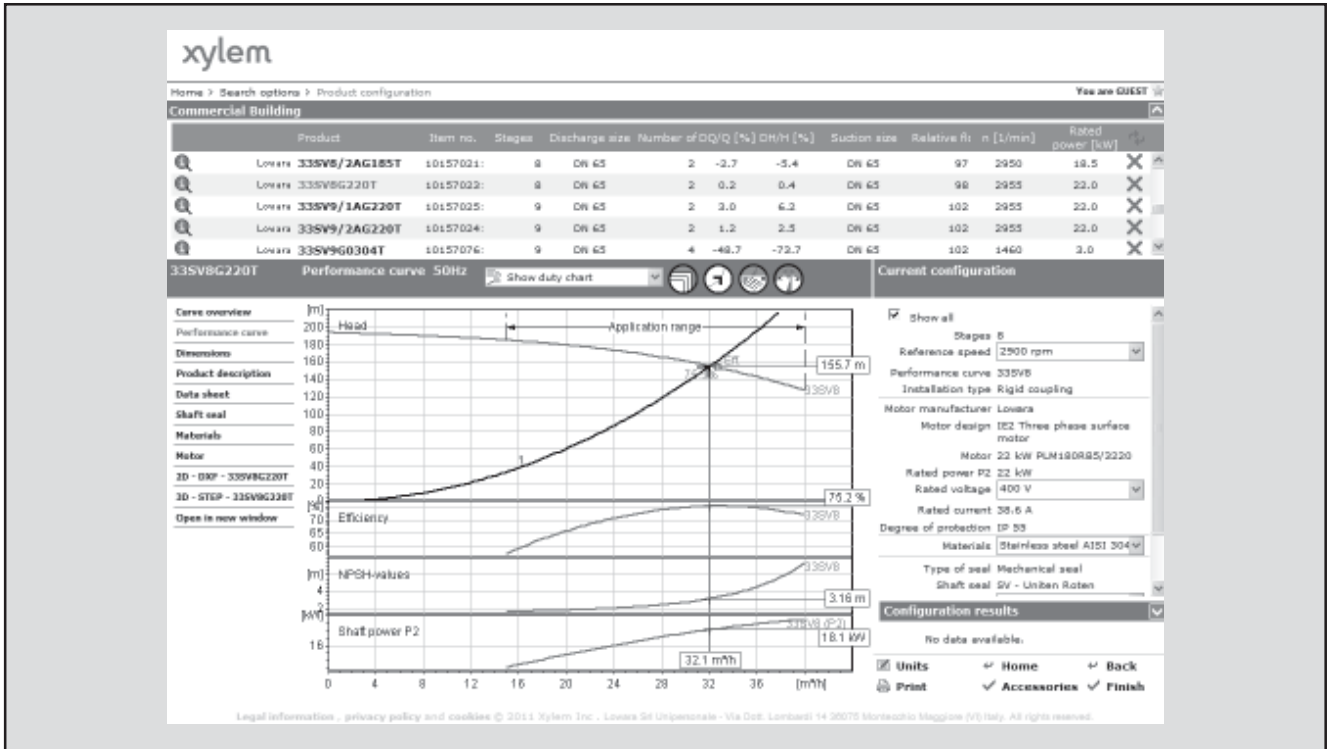

The detailed output makes it easy to select the optimal pump from the given alternatives.

The best way to work with Xylect™ is to create a personal account. This makes it possible to:

- Set own standard units
- Create and save projects
- Share projects with other Xylect™ users

Every user have a My Xylect space, where all projects are saved.

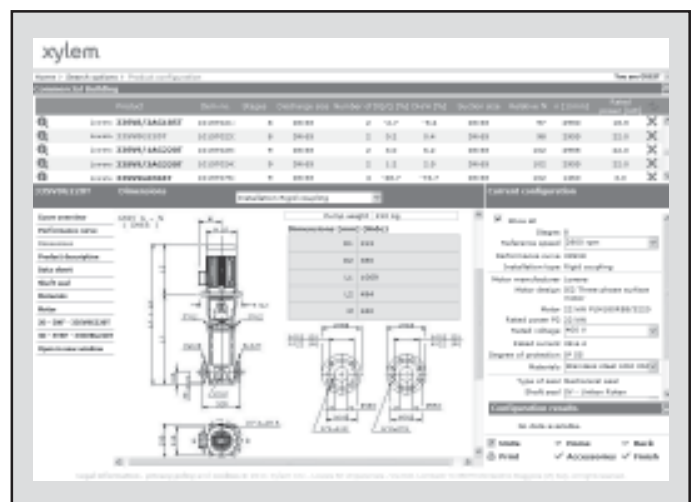

Dimensional drawings appear on the screen and can be downloaded in dxf format.

Xylem |'zīləm|

- 1) The tissue in plants that brings water upward from the roots;
- 2) a leading global water technology company.

We're approximately 12,700 people unified in a common purpose: creating innovative solutions to meet our world's water needs. Developing new technologies that will improve the way water is used, conserved, and re-used in the future is central to our work. We move, treat, analyze, and return water to the environment, and we help people use water efficiently, in their homes, buildings, factories and farms. In more than 150 countries, we have strong, long-standing relationships with customers who know us for our powerful combination of leading product brands and applications expertise, backed by a legacy of innovation.



LENNTECH
WATER TREATMENT SOLUTIONS

info@lennotech.com Tel. +31-152-610-900

www.lennotech.com Fax. +31-152-616-289