

**ErP**  
ready

# CIRCULATORS

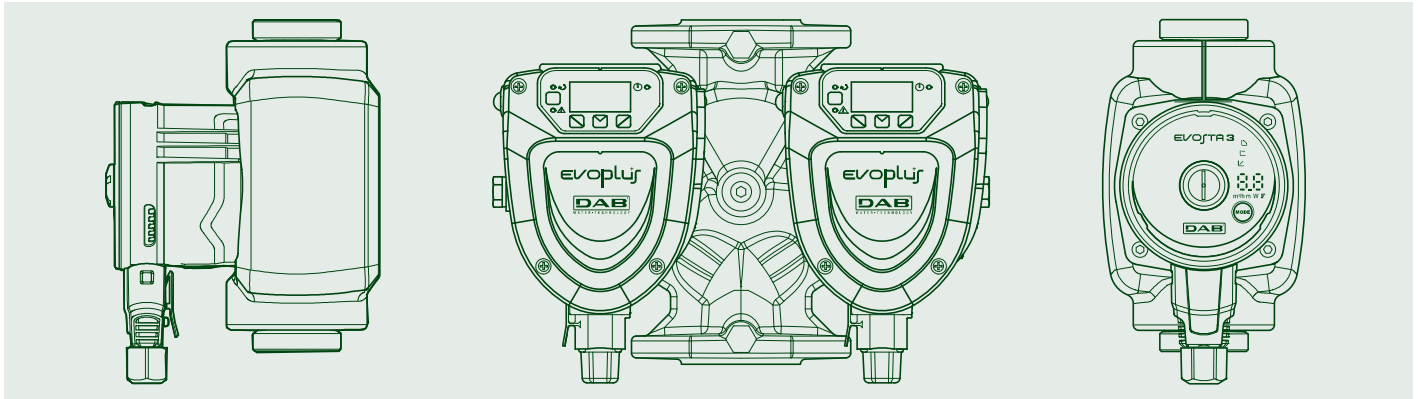

# TECHNICAL CATALOGUE

# BPH / BMH / DPH / DMH

## WET ROTOR CIRCULATORS

ONLY FOR  
**EXTRA EU**  
MARKETS



### TECHNICAL DATA

**Operating range:** from 1,5 a 78 m<sup>3</sup>/h with head of up to 18 metres

**Liquid temperature range:** for three-phase version: from -10°C to +120°C (for the models BPH-DPH 150/340.65 T and BPH-DPH 150/360.80 T; BPH-DPH 150-180/280.50 T; BPH-DPH 180/340.65 T; BPH-DPH 180/360.80 T: from -10°C to +110°C)

**Pumped liquid:** clean, free of solids and mineral oils, non-viscous, chemically neutral, with properties similar to water. (glycol max 30%)

**Maximum operating pressure:** 10 bar (1000 kPa)

**Standard flanges:** DN 80 in PN 6 / PN 10 (4 holes)

Minimum suction pressure: the values are shown in the corresponding tables

**Installation:** with HORIZONTAL MOTOR AXIS, on the delivery or return piping, with the suction port as close as possible to the expansion vessel, above the level of the boiler and as far as possible from bends, elbows, branches, to avoid water turbulence, and the consequent noise

**Special executions on requests:** alternative voltages and frequencies DN 80 in PN 10 / PN 16 (8 holes) flange

**Accessories:** DN 40, DN 50, DN 65, DN 80 in PN 6 / PN 10 (4 slots)

### APPLICATIONS

Pump for the circulation of water in residential and industrial collective heating and air conditioning systems. All the models are available both in the single and twin version.

### CONSTRUCTION FEATURES

Single body consisting of the cast iron hydraulic section, and the wet rotor motor.

Aluminium motor casing. Flanged suction and delivery ports with threaded connectors for control manometers. Technopolymer impeller, tempered stainless steel motor shaft on graphite bushings lubricated by the pumped liquid. Stainless steel rotor protection liner and stator liner. Ceramic thrust ring, ethylene-propylene seal rings, and brass air breather plug. Asynchronous four-pole motor for the BMH and DMH versions, two poles for the BPH and DPH versions. The single-phase circulator has been designed for three-speed operation at 230 V, while the three-phase circulator has been designed for two-speed operation at 230 V, and 3-speed operation at 400 V. In both cases, the speed is adjusted through a special selector in the terminal box, in order to adapt the operation of the circulator to the characteristics of the system.

Built-in thermal protection in the single-phase version. For the three-phase version, the motor must be connected to the power input using an external contactor. The contactor must be connected to the thermal protection built in the motor, in order to protect it from overload at all speeds.

The twin version features an automatic swing check valve incorporated in the delivery port, to avoid water recirculating through the unit when this is not running; in addition, a blank flange is also supplied as standard, to allow either of the two motors to be removed for servicing. The standard execution of the pump body is in PN 10, compatible with PN 6 pumps to ensure interchangeability of the pumps in existing systems.

Circulator protection class: IP 44 for both the single-phase and the three-phase version

Insulation class: H - Cable gland: PG 11

Standard voltage: three-phase 230/400 V, 50 Hz

Product compliant with European Standards EN 60335-2-51

### MATERIALS

N.	PARTS	MATERIALS
1	PUMP BODY	CAST IRON 200 UNI ISO 185
4	IMPELLER	TECHNOPOLYMER B
7A	MOTOR SHAFT	AISI 420 C QUENCHED AND TEMPERED STAINLESS STEEL
7B	ROTOR	-
8	STATOR	-
10	MOTOR CASING	DIE-CAST ALUMINIUM
11	BREATHER PLUG	BRASS P Cu Zn 40 Pb2 UNI 5705
100	TERMINAL BOX	-
127	SEAL RING	ETHYLENE PROPYLENE (EPDM)
128	STATOR LINER	AISI 321 STAINLESS STEEL AISI 304 QUENCHED AND TEMPERED
129	ROTOR LINER	AISI 321 STAINLESS STEEL AISI 304 QUENCHED AND TEMPERED
130	CLOSING FLANGE	CAST IRON 200 UNI ISO 185
131	THRUST RING SUPPORT	AISI 304 L STAINLESS STEEL
132	BUSHINGS	EC 941 CARBON

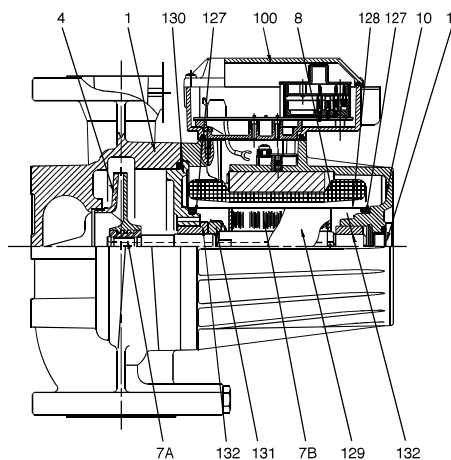

# BPH / BMH / DPH / DMH

## WET ROTOR CIRCULATORS

– Legend:  
(example)

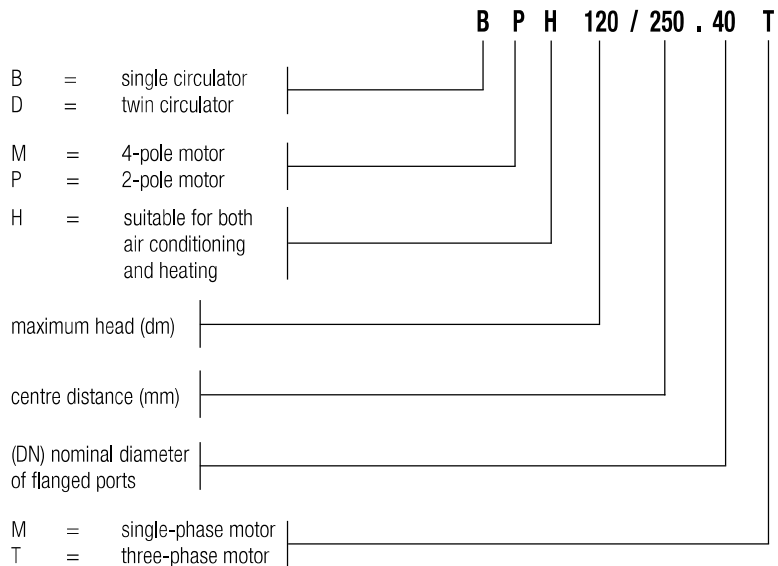

### TERMINAL BOX POSITION

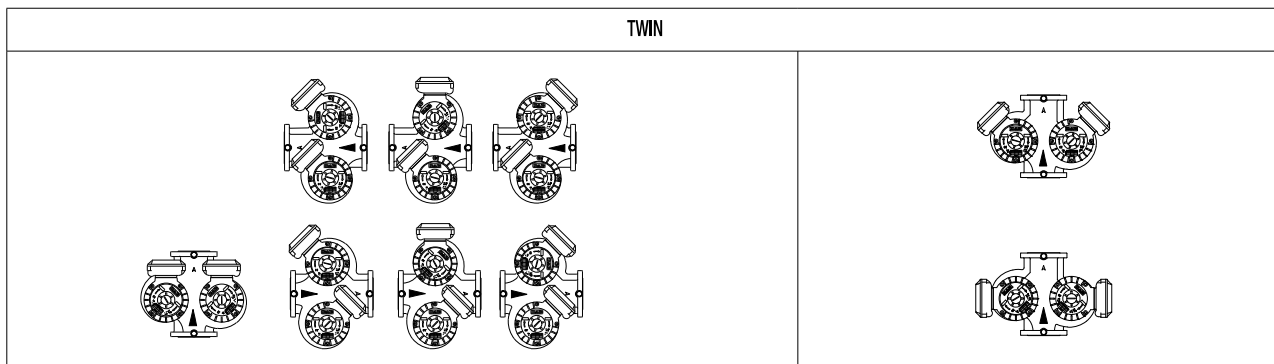
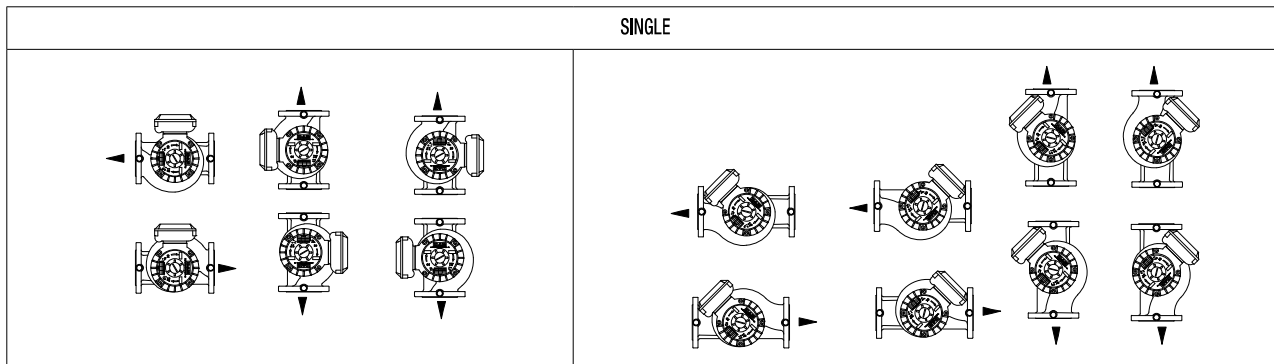

# BPH / BMH / DPH / DMH

## WET ROTOR CIRCULATORS

### PERFORMANCE RANGE

The performance curves are based on kinematic viscosity values = 1 mm<sup>2</sup>/s and density equal to 1000 kg/m<sup>3</sup>. Curve tolerance according to ISO 9906.

### GRAPHIC SELECTION TABLE

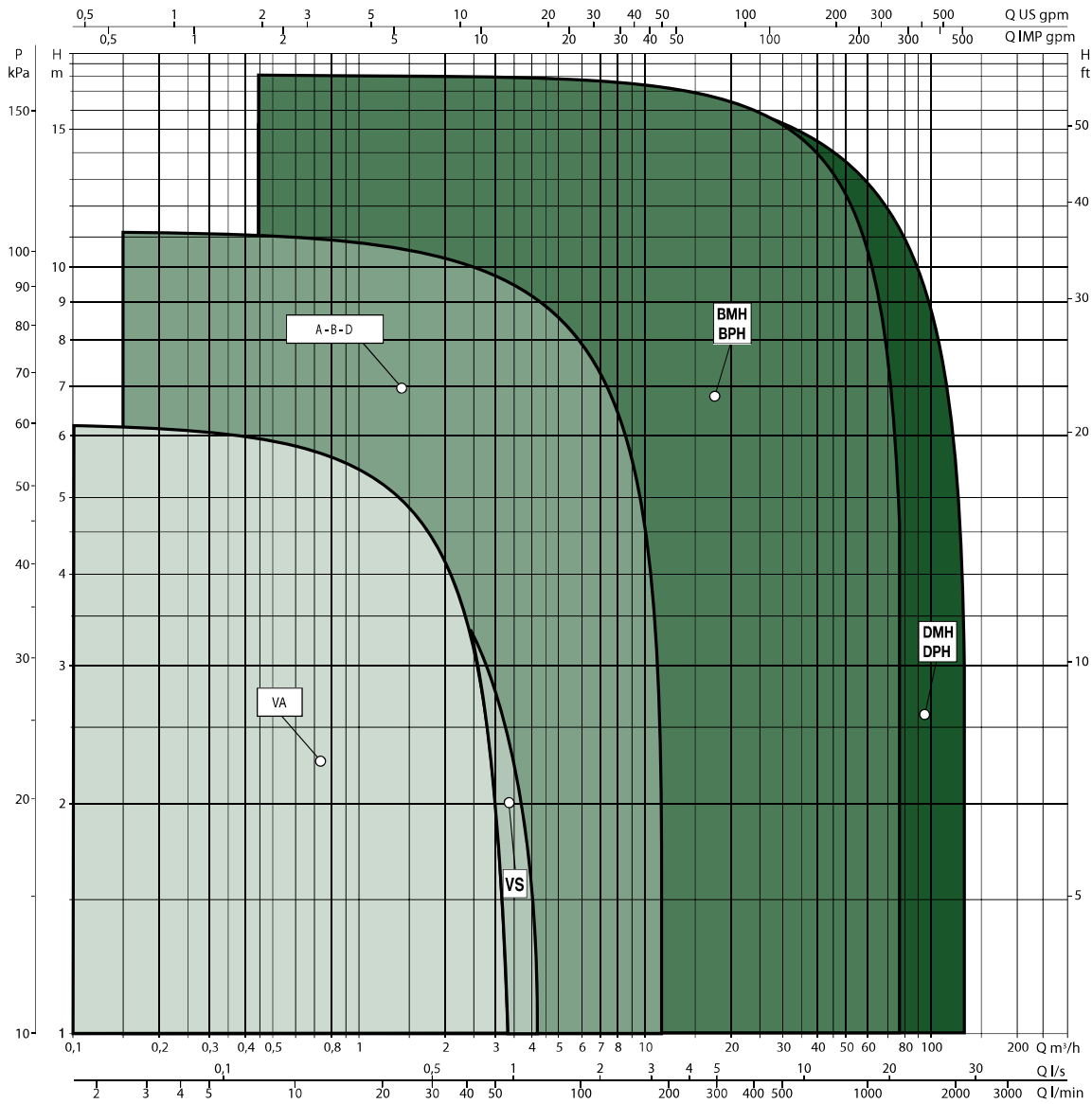

WET ROTOR CIRCULATORS

# BPH / BMH / DPH / DMH

## WET ROTOR CIRCULATORS

### SELECTION TABLE - BPH / BMH

MODEL	Q=m³/h	0	1,8	2,4	3	4,2	5,4	7,2	9,6	12	14,4	18	24	30	36	42	54	72	
	Q=l/min	0	30	40	50	70	90	120	160	200	240	300	400	500	600	700	900	1200	
BMH 30/250.40 T	H (m)	3,3	3,1	2,95	2,85	2,5	2,1	1,15											
BPH 60/250.40 M		7,2	6,8	6,7	6,5	6,2	5,8	5	3,7	2									
BPH 60/250.40 T		7,65	7,4	7,3	7,2	6,8	6,4	5,45	3,9	2,25									
BPH 120/250.40 M		11	10,3	10,1	9,8	9,2	8,6	7,65	6,2	4,35	2,4								
BPH 120/250.40 T		12		11	10,7	10,1	9,5	8,4	6,8	4,7	2,2								
BMH 30/280.50 T		3,15		3,02	3	2,93	2,85	2,65	2,3	1,75	1,2								
BMH 60/280.50 T		5,83		5,65	5,6	5,49	5,35	5,1	4,75	4,2	3,65	2,62							
BPH 60/280.50 M		7,65	7,5	7,45	7,4	7,3	7,2	6,98	6,7	6,2	5,75	4,6	2,3						
BPH 60/280.50 T		7,95		7,75	7,7	7,6	7,5	7,35	6,92	6,45	5,85	4,65	2,4						
BPH 120/280.50 M		11,3				10,8	10,5	10,3	9,9	9,4	8,5	7,2	4,8	2,1					
BPH 120/280.50 T		11,7				11,3	11	10,75	10,25	9,6	8,9	7,75	5,4	2,6					
BPH 150/280.50 T		15				14,6	14,4	14	13,6	12,7	11,8	10,5	7,5						
BPH 180/280.50 T		18,4						17,4	17	16,4	15,6	14,4	12	8,8	5,2				
BMH 30/340.65 T		3,15				3,09	3,02	2,98	2,85	2,55	2,25	1,65							
BMH 60/340.65 T		5,4				5,15	5,05	4,9	4,7	4,45	4,1	3,45	2,25						
BPH 60/340.65 M		6,8	6,79	6,75	6,7	6,6	6,57	6,5	6,35	6,2	5,95	5,5	4,35	2,85	1,2				
BPH 60/340.65 T		7,4				7,35	7,3	7,24	7,1	6,9	6,65	6,15	4,9	3,3	1,4				
BPH 120/340.65 T		10,9				10,75	10,68	10,6	10,5	10,38	10,2	9,8	8,7	7,15	5,2	3			
BPH 150/340.65 T		14,9				14,88	14,83	14,75	14,65	14,55	14,3	13,88	12,65	11	9,35	7,15			
BPH 180/340.65 T		17,9						17,8	17,7	17,5	17,3	16,8	15,7	14,1	12,1	10			
BMH 30/360.80 T		3,9						3,85	3,8	3,75	3,65	3,48	3,1	2,45	1,75				
BMH 60/360.80 T		5,7						5,66	5,61	5,59	5,5	5,4	5	4,55	3,9	3,1			
BPH 120/360.80 T		11,8						11,65	11,58	11,5	11,4	11,25	10,75	10,2	9,39	8,37	5,65		
BPH 150/360.80 T		15,3						15,1	15,06	14,99	14,92	14,75	14,5	14	13,4	12,4	10,3	6	
BPH 180/360.80 T		17,5						17,4	17,25	17,1	16,8	16,25	15	13,7	12	10,1	5,5		

WET ROTOR CIRCULATORS

### SELECTION TABLE - DPH / DMH

MODEL	Q=m³/h	0	1,8	2,4	3	4,2	5,4	7,2	9,6	12	14,4	18	24	30	36	42	54	72	
	Q=l/min	0	30	40	50	70	90	120	160	200	240	300	400	500	600	700	900	1200	
DMH 30/250.40 T	H (m)	3,3	3,1	2,95	2,85	2,5	2,1	1,15											
DPH 60/250.40 M		7,2	6,8	6,7	6,5	6,2	5,8	5	3,7	2									
DPH 60/250.40 T		7,65	7,4	7,3	7,2	6,8	6,4	5,45	3,9	2,25									
DPH 120/250.40 M		11	10,3	10,1	9,8	9,2	8,6	7,65	6,2	4,35	2,4								
DPH 120/250.40 T		12		11	10,7	10,1	9,5	8,4	6,8	4,7	2,2								
DMH 30/280.50 T		3,15		3,02	3	2,93	2,85	2,65	2,3	1,75	1,2								
DMH 60/280.50 T		5,83		5,65	5,6	5,49	5,35	5,1	4,75	4,2	3,65	2,62							
DPH 60/280.50 M		7,65	7,5	7,45	7,4	7,3	7,2	6,98	6,7	6,2	5,75	4,6	2,3						
DPH 60/280.50 T		7,95		7,75	7,7	7,6	7,5	7,35	6,92	6,45	5,85	4,65	2,4						
DPH 120/280.50 M		11,3				10,8	10,5	10,3	9,9	9,4	8,5	7,2	4,8	2,1					
DPH 120/280.50 T		11,7				11,3	11	10,75	10,25	9,6	8,9	7,75	5,4	2,6					
DPH 150/280.50 T		15				14,6	14,4	14	13,6	12,7	11,8	10,5	7,5						
DPH 180/280.50 T		18,4						17,4	17	16,4	15,6	14,4	12	8,8	5,2				
DMH 30/340.65 T		3,15				3,09	3,02	2,98	2,85	2,55	2,25	1,65							
DMH 60/340.65 T		5,4				5,15	5,05	4,9	4,7	4,45	4,1	3,45	2,25						
DPH 60/340.65 M		6,8	6,79	6,75	6,7	6,6	6,57	6,5	6,35	6,2	5,95	5,5	4,35	2,85	1,2				
DPH 60/340.65 T		7,4				7,35	7,3	7,24	7,1	6,9	6,65	6,15	4,9	3,3	1,4				
DPH 120/340.65 T		10,9				10,75	10,68	10,6	10,5	10,38	10,2	9,8	8,7	7,15	5,2	3			
DPH 150/340.65 T		14,9				14,88	14,83	14,75	14,65	14,55	14,3	13,88	12,65	11	9,35	7,15			
DPH 180/340.65 T		17,9						17,8	17,7	17,5	17,3	16,8	15,7	14,1	12,1	10			
DMH 30/360.80 T		3,9						3,85	3,8	3,75	3,65	3,48	3,1	2,45	1,75				
DMH 60/360.80 T		5,7						5,66	5,61	5,59	5,5	5,4	5	4,55	3,9	3,1			
DPH 120/360.80 T		11,8						11,65	11,58	11,5	11,4	11,25	10,75	10,2	9,39	8,37	5,65		
DPH 150/360.80 T		15,3						15,1	15,06	14,99	14,92	14,75	14,5	14	13,4	12,4	10,3	6	
DPH 180/360.80 T		17,5						17,4	17,25	17,1	16,8	16,25	15	13,7	12	10,1	5,5		

## BMH 30/250.40 T - WET ROTOR CIRCULATORS

Pumped liquid temperature range: from -10 °C to +120 °C - Maximum operating pressure: 10 bar (1000 kPa)

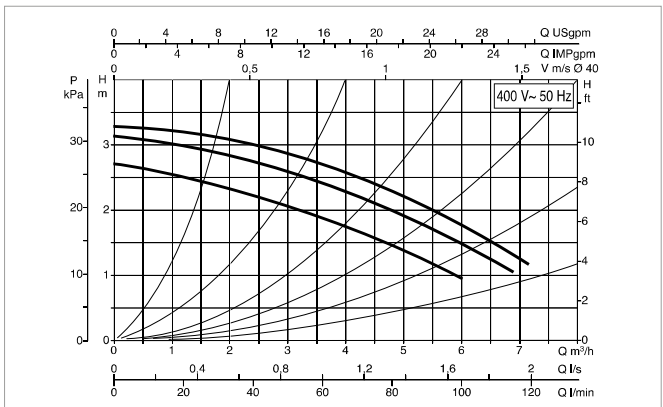
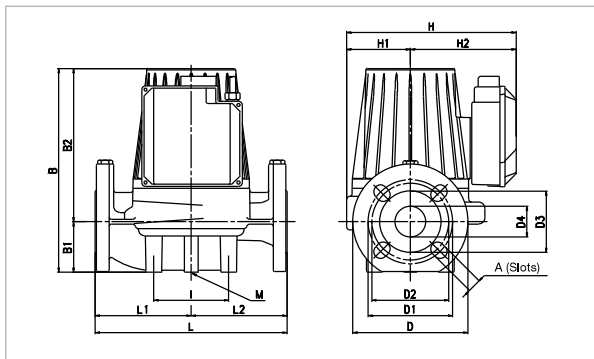

The performance curves are based on kinematic viscosity values = 1 mm²/s and density equal to 1000 kg/m³. Curve tolerance according to ISO 9906.

MODEL	CENTRE DISTANCE mm	COUNTERFLANGES ON REQUEST	ELECTRICAL DATA					MINIMUM SUCTION PRESSURE				
			POWER INPUT 50 Hz	SPEED	REV. 1/min	P1 MAX W	In A	t°	75°	90°	110°	120°
								m.c.v.				
BMH 30/250.40 T	250	DN 40 - PN 10	3x230 V ~	2	1340	100	0.48	m.c.v.	0.9	4	-	18
			3x400 V ~	1	1260	88	0.39					
			3	2	1440	192	0.78					
			2	1	1430	155	0.58					
			1	1	1260	88	0.23					

MODEL	L	L1	L2	A	B	B1	B2	D	D1	D2	D3	D4	I	I1	I2	I3	M	H	H1	H2	WEIGHT kg
BMH 30/250.40 T	250	125	125	18	266	66	200	150	110	100	80	40	100	-	-	-	M10	221	83	138	17,5

## BPH 60/250.40 M - WET ROTOR CIRCULATORS

Pumped liquid temperature range: from -10 °C to +110 °C - Maximum operating pressure: 10 bar (1000 kPa)

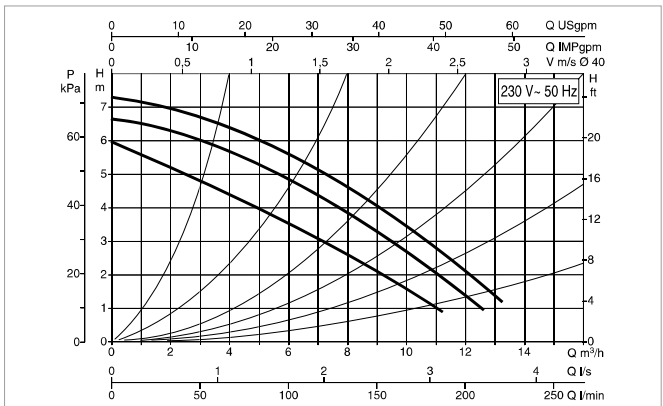
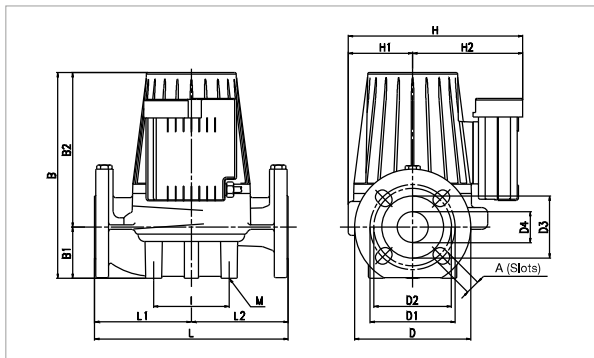

The performance curves are based on kinematic viscosity values = 1 mm²/s and density equal to 1000 kg/m³. Curve tolerance according to ISO 9906.

MODEL	CENTRE DISTANCE mm	FLANGES ON REQUEST	ELECTRICAL DATA					MINIMUM SUCTION PRESSURE				
			POWER INPUT 50 Hz	SPEED	REV. 1/min	P1 MAX W	In A	t°	75°	90°	110°	120°
								m.c.v.				
BPH 60/250.40 M	250	DN 40 - PN 10	1x230 V ~	3	2830	316	1.43	m.c.v.	1.6	4	14	-
				2	2750	309	1.53					
				1	2410	292	1.51					

MODEL	L	L1	L2	A	B	B1	B2	D	D1	D2	D3	D4	I	I1	I2	I3	M	H	H1	H2	WEIGHT kg
BPH 60/250.40 M	250	125	125	18	266	66	200	150	110	100	80	40	100	-	-	-	M10	221	83	138	17,5

## BPH 60/250.40 T - WET ROTOR CIRCULATORS

Pumped liquid temperature range: from -10 °C to +120 °C - Maximum operating pressure: 10 bar (1000 kPa)

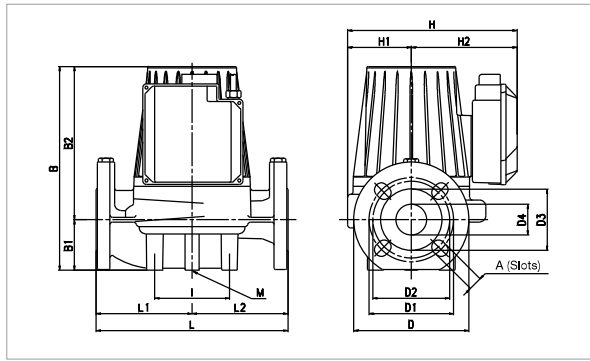

The performance curves are based on kinematic viscosity values = 1 mm<sup>2</sup>/s and density equal to 1000 kg/m<sup>3</sup>. Curve tolerance according to ISO 9906.

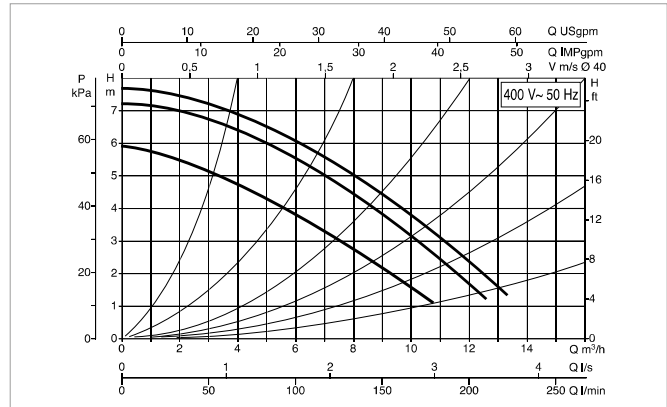

MODEL	CENTRE DISTANCE mm	COUNTERFLANGES ON REQUEST	ELECTRICAL DATA					MINIMUM SUCTION PRESSURE					
			POWER INPUT 50 Hz	SPEED	REV. 1/min	P1 MAX W	I <sub>n</sub> A	t°	75°	90°	110°	120°	
BPH 60/250.40 T	250	DN 40 - PN 10	3x230 V ~	2	2570	253	0.81	m.c.w.	1,6	4	-	19	
				1	2420	229	0.72						
			3x400 V ~	3	2850	348	0.99						
				2	2810	316	0.75						
				1	2	2430	232						0.42
					1								

MODEL	L	L1	L2	A	B	B1	B2	D	D1	D2	D3	D4	I	I1	I2	I3	M	H	H1	H2	WEIGHT kg
BPH 60/250.40 T	250	125	125	18	266	66	200	150	110	100	80	40	100	-	-	-	M10	221	83	138	17,5

## BPH 120/250.40 M - WET ROTOR CIRCULATORS

Pumped liquid temperature range: from -10 °C to +110 °C - Maximum operating pressure: 10 bar (1000 kPa)

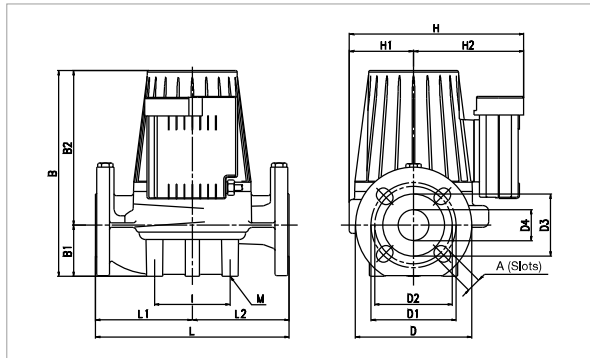

The performance curves are based on kinematic viscosity values = 1 mm<sup>2</sup>/s and density equal to 1000 kg/m<sup>3</sup>. Curve tolerance according to ISO 9906.

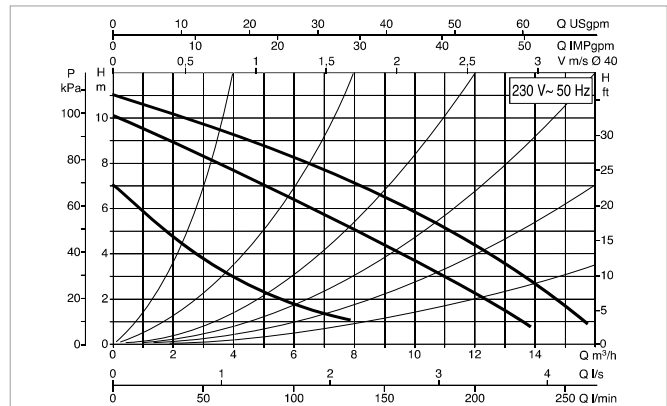

MODEL	CENTRE DISTANCE mm	COUNTERFLANGES ON REQUEST	ELECTRICAL DATA					MINIMUM SUCTION PRESSURE				
			POWER INPUT 50 Hz	SPEED	REV. 1/min	P1 MAX W	I <sub>n</sub> A	t°	75°	90°	110°	120°
BPH 120/250.40 M	250	DN 40 - PN 10	1x230 V ~	3	2650	510	2,24	m.c.w.	6	9	18	-
				2	2320	498	2,35					
				1	1520	376	1,96					

MODEL	L	L1	L2	A	B	B1	B2	D	D1	D2	D3	D4	I	I1	I2	I3	M	H	H1	H2	WEIGHT kg
BPH 120/250.40 M	250	125	125	18	266	66	200	150	110	100	80	40	100	-	-	-	M10	221	83	138	17,5

## BPH 120/250.40 T - WET ROTOR CIRCULATORS

Pumped liquid temperature range: from -10 °C to +120 °C - Maximum operating pressure: 10 bar (1000 kPa)

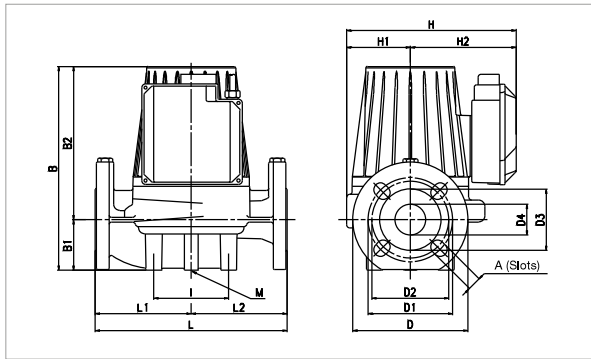

The performance curves are based on kinematic viscosity values = 1 mm<sup>2</sup>/s and density equal to 1000 kg/m<sup>3</sup>. Curve tolerance according to ISO 9906.

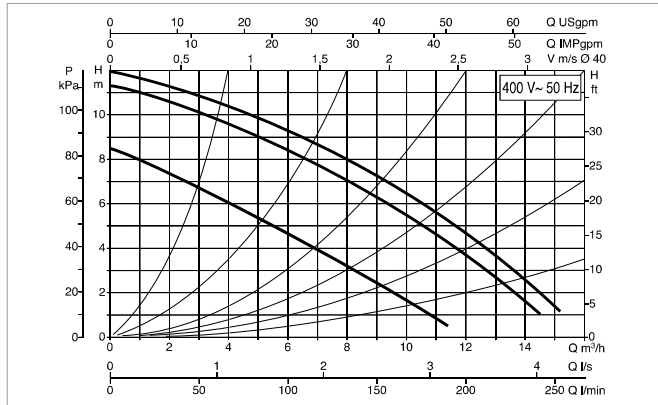

MODEL	CENTRE DISTANCE mm	COUNTERFLANGES ON REQUEST	ELECTRICAL DATA					MINIMUM SUCTION PRESSURE					
			POWER INPUT 50 Hz	SPEED	REV. 1/min	P1 MAX W	In A	t°	75°	90°	110°	120°	
BPH 120/250.40 T	250	DN 40 - PN 10	3x230 V ~	2	2300	395	1.2	m.c.w.	6	9	-	23	
				1	2070	340	1.07						
			3x400 V ~	3	2780	536	1.16						
				2	2710	499	0.98						
				1	2	2080	339						0.62
					1								

MODEL	L	L1	L2	A	B	B1	B2	D	D1	D2	D3	D4	I	I1	I2	I3	M	H	H1	H2	WEIGHT kg
BPH 120/250.40 T	250	125	125	18	266	66	200	150	110	100	80	40	100	-	-	-	M10	221	83	138	17,5

## BMH 30/280.50 T - WET ROTOR CIRCULATORS

Pumped liquid temperature range: from -10 °C to +120 °C - Maximum operating pressure: 10 bar (1000 kPa)

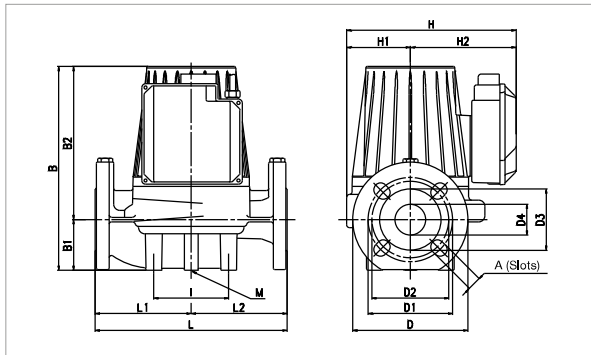

The performance curves are based on kinematic viscosity values = 1 mm<sup>2</sup>/s and density equal to 1000 kg/m<sup>3</sup>. Curve tolerance according to ISO 9906.

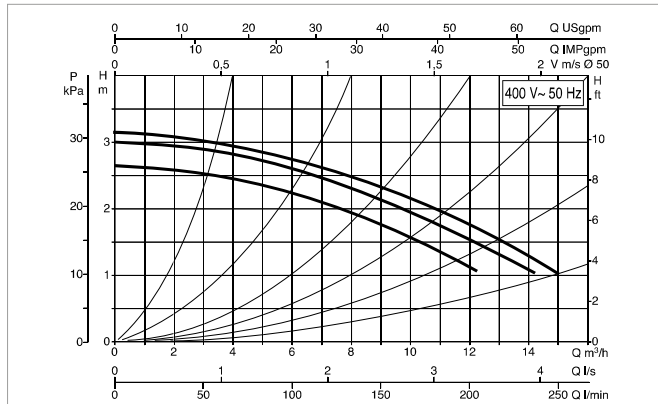

MODEL	CENTRE DISTANCE mm	COUNTERFLANGES ON REQUEST	ELECTRICAL DATA					MINIMUM SUCTION PRESSURE					
			POWER INPUT 50 Hz	SPEED	REV. 1/min	P1 MAX W	In A	t°	75°	90°	110°	120°	
BMH 30/280.50 T	280	DN 50 - PN 10	3x230 V ~	2	1390	148	0.7	m.c.w.	0,9	4	-	18	
				1	1340	134	0.55						
			3x400 V ~	3	1460	255	1.12						
				2	1450	216	0.83						
				1	2	1350	131						0.32
					1								

MODEL	L	L1	L2	A	B	B1	B2	D	D1	D2	D3	D4	I	I1	I2	I3	M	H	H1	H2	WEIGHT kg
BMH 30/280.50 T	280	140	140	18	312	73	239	165	125	110	90	50	100	-	-	-	M10	254	96	158	24



## BMH 60/280.50 T - WET ROTOR CIRCULATORS

Pumped liquid temperature range: from -10 °C to +120 °C - Maximum operating pressure: 10 bar (1000 kPa)

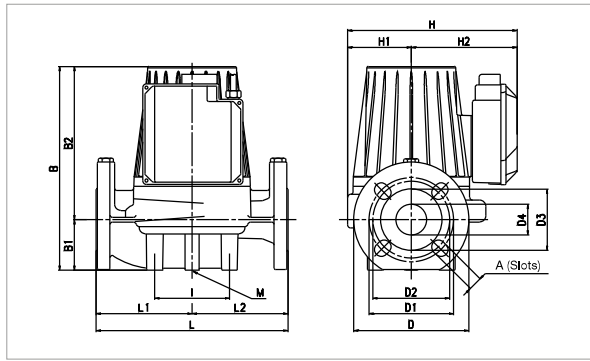

The performance curves are based on kinematic viscosity values = 1 mm<sup>2</sup>/s and density equal to 1000 kg/m<sup>3</sup>. Curve tolerance according to ISO 9906.

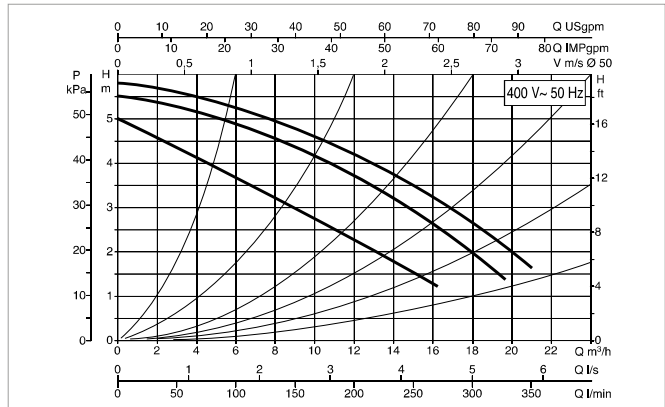

MODEL	CENTRE DISTANCE mm	COUNTERFLANGES ON REQUEST	ELECTRICAL DATA					MINIMUM SUCTION PRESSURE				
			POWER INPUT 50 Hz	SPEED	REV. 1/min	P1 MAX W	In A	t°	75°	90°	110°	120°
								m.c.w.	4	7.5	-	21
BMH 60/280.50 T	280	DN 50 - PN 10	3x230 V -	2	1210	272	0.94	m.c.w.	4	7.5	-	21
				1	1120	240	0.8					
			3x400 V -	3	1400	410	1.2					
				2	1360	367	0.95					
				1	1130	235	0.46					

MODEL	L	L1	L2	A	B	B1	B2	D	D1	D2	D3	D4	I	I1	I2	I3	M	H	H1	H2	WEIGHT kg
BMH 60/280.50 T	280	140	140	18	312	73	239	165	125	110	90	50	100	-	-	-	M10	254	96	158	24

## BPH 60/280.50 M - WET ROTOR CIRCULATORS

Pumped liquid temperature range: from -10 °C to +110 °C - Maximum operating pressure: 10 bar (1000 kPa)

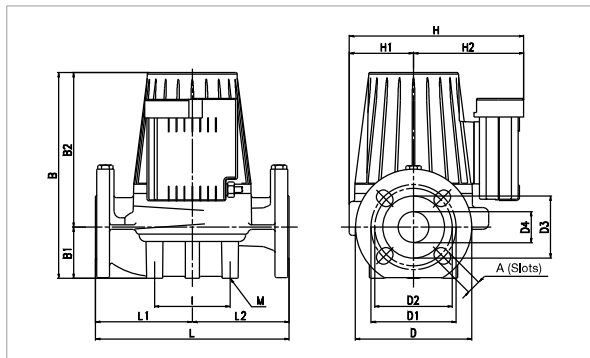

The performance curves are based on kinematic viscosity values = 1 mm<sup>2</sup>/s and density equal to 1000 kg/m<sup>3</sup>. Curve tolerance according to ISO 9906.

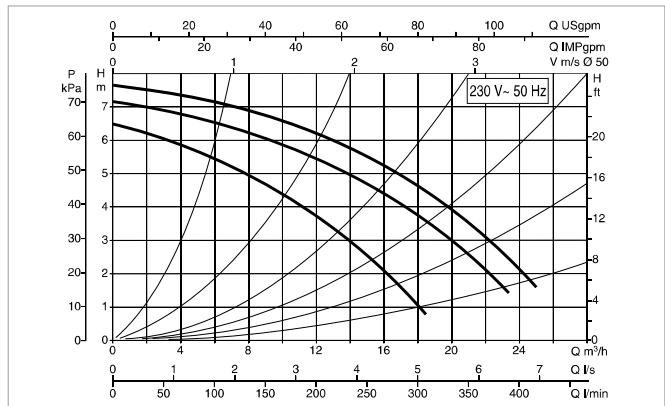

MODEL	CENTRE DISTANCE mm	COUNTERFLANGES ON REQUEST	ELECTRICAL DATA					MINIMUM SUCTION PRESSURE				
			POWER INPUT 50 Hz	SPEED	REV. 1/min	P1 MAX W	In A	t°	75°	90°	110°	120°
								m.c.w.	1.6	6	14	-
BPH 60/280.50 M	280	DN 50 - PN 10	1x230 V -	3	2840	595	2.79	m.c.w.	1.6	6	14	-
				2	2730	540	2.45					
				1	2200	506	2.58					

MODEL	L	L1	L2	A	B	B1	B2	D	D1	D2	D3	D4	I	I1	I2	I3	M	H	H1	H2	WEIGHT kg
BPH 60/280.50 M	280	140	140	18	312	73	239	165	125	110	90	50	100	-	-	-	M10	254	96	158	24

## BPH 60/280.50 T - WET ROTOR CIRCULATORS

Pumped liquid temperature range: from -10 °C to +120 °C - Maximum operating pressure: 10 bar (1000 kPa)

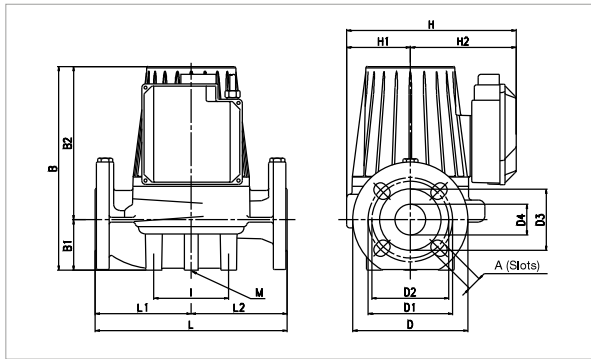

The performance curves are based on kinematic viscosity values = 1 mm<sup>2</sup>/s and density equal to 1000 kg/m<sup>3</sup>. Curve tolerance according to ISO 9906.

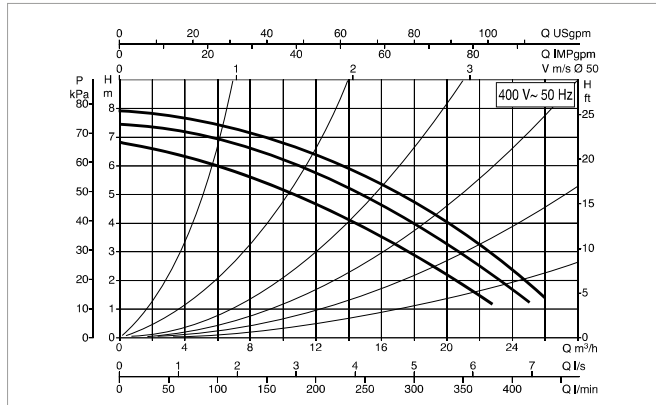

MODEL	CENTRE DISTANCE mm	COUNTERFLANGES ON REQUEST	ELECTRICAL DATA					MINIMUM SUCTION PRESSURE				
			POWER INPUT 50 Hz	SPEED	REV. 1/min	P1 MAX W	In A	t°	75°	90°	110°	120°
								m.c.w.	1,6	6	-	19
BPH 60/280.50 T	280	DN 50 - PN 10	3x230 V ~	2	2670	464	1.35					
			3x400 V ~	1	2570	432	1.23					
				3	2890	589	1.31					
				2	2860	546	1.1					
				1	2570	423	0.71					

MODEL	L	L1	L2	A	B	B1	B2	D	D1	D2	D3	D4	I	I1	I2	I3	M	H	H1	H2	WEIGHT kg
BPH 60/280.50 T	280	140	140	18	312	73	239	165	125	110	90	50	100	-	-	-	M10	254	96	158	24

## BPH 120/280.50 M - WET ROTOR CIRCULATORS

Pumped liquid temperature range: from -10 °C to + 90 °C - Maximum operating pressure: 10 bar (1000 kPa)

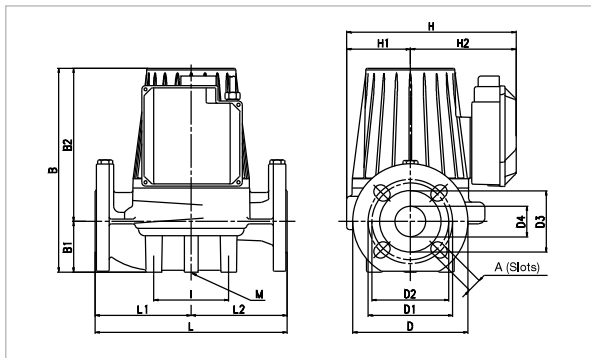

The performance curves are based on kinematic viscosity values = 1 mm<sup>2</sup>/s and density equal to 1000 kg/m<sup>3</sup>. Curve tolerance according to ISO 9906.

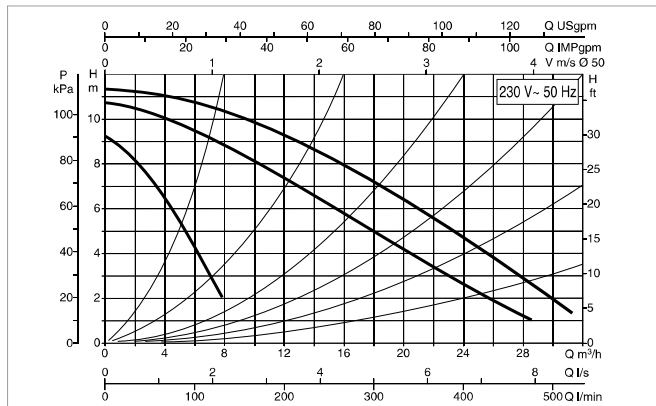

MODEL	CENTRE DISTANCE mm	COUNTERFLANGES ON REQUEST	ELECTRICAL DATA					MINIMUM SUCTION PRESSURE				
			POWER INPUT 50 Hz	SPEED	REV. 1/min	P1 MAX W	In A	t°	75°	90°	110°	120°
								m.c.w.	2	5	-	20
BPH 120/280.50 M	280	DN 50 - PN 10	1x230 V ~	3	2690	870	3.97					
				2	2360	800	3.69					
				1	1340	590	3.12					

MODEL	L	L1	L2	A	B	B1	B2	D	D1	D2	D3	D4	I	I1	I2	I3	M	H	H1	H2	WEIGHT kg
BPH 120/280.50 M	280	140	140	18	312	73	239	165	125	110	90	50	100	-	-	-	M10	254	96	158	24

## BPH 120/280.50 T - WET ROTOR CIRCULATORS

Pumped liquid temperature range: from -10 °C to +120 °C - Maximum operating pressure: 10 bar (1000 kPa)

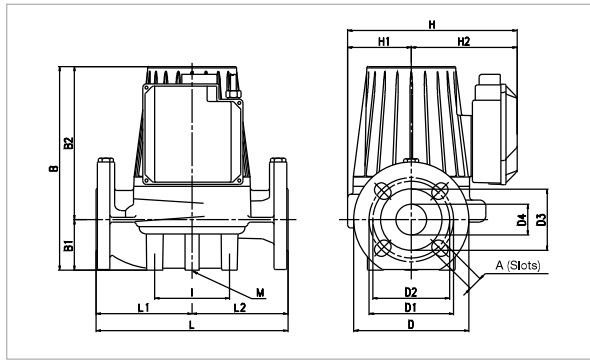

The performance curves are based on kinematic viscosity values = 1 mm<sup>2</sup>/s and density equal to 1000 kg/m<sup>3</sup>. Curve tolerance according to ISO 9906.

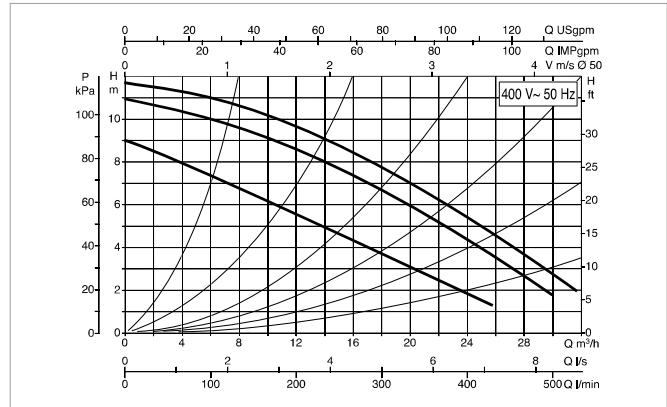

MODEL	CENTRE DISTANCE mm	COUNTERFLANGES ON REQUEST	ELECTRICAL DATA					MINIMUM SUCTION PRESSURE				
			POWER INPUT 50 Hz	SPEED	REV. 1/min	P1 MAX W	In A	t°	75°	90°	110°	120°
BPH 120/280.50 T	280	DN 50 - PN 10	3x230 V ~	2	2430	683	1.95	m.c.w.	2	5	-	20
				1	2240	605	1.75					
			3x400 V ~	3	2810	898	1.67					
				2	2740	840	1.47					
			1	2260	603	1						

MODEL	L	L1	L2	A	B	B1	B2	D	D1	D2	D3	D4	I	I1	I2	I3	M	H	H1	H2	WEIGHT kg
BPH 120/280.50 T	280	140	140	18	312	73	239	165	125	110	90	50	100	-	-	-	M10	254	96	158	26

## BPH 150/280.50 T - WET ROTOR CIRCULATORS

Pumped liquid temperature range: from -10 °C to +110 °C - Maximum operating pressure: 10 bar (1000 kPa)

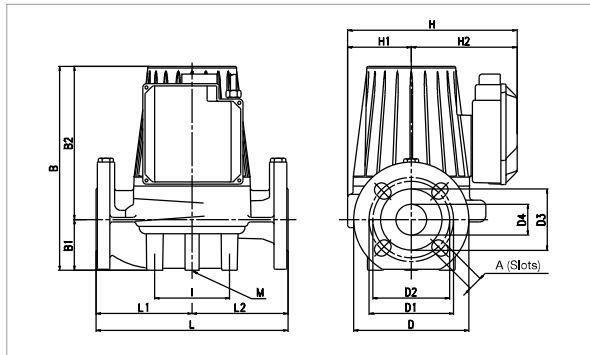

The performance curves are based on kinematic viscosity values = 1 mm<sup>2</sup>/s and density equal to 1000 kg/m<sup>3</sup>. Curve tolerance according to ISO 9906.

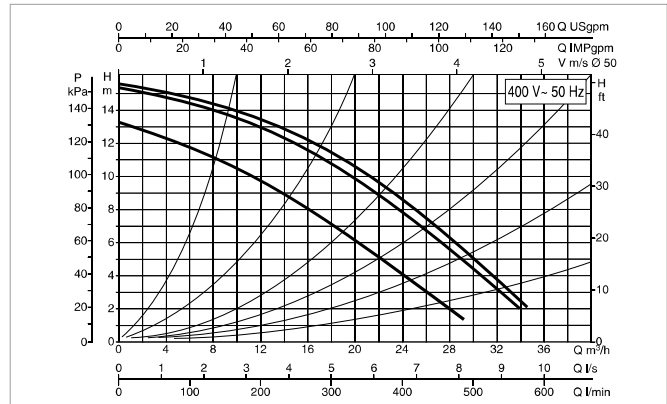

MODEL	CENTRE DISTANCE mm	COUNTERFLANGES ON REQUEST	ELECTRICAL DATA					MINIMUM SUCTION PRESSURE				
			POWER INPUT 50 Hz	SPEED	REV. 1/min	P1 MAX W	In A	t°	75°	90°	110°	120°
BPH 150/280.50 T	280	DN 50 - PN 10	3x230 V ~	2	2553	1130	3.22	m.c.w.	2	5	-	20
				1	2420	1032	3					
			3x400 V ~	3	2850	1470	2.9					
				2	2802	1360	2.5					
			1	2425	1030	1.7						

MODEL	L	L1	L2	A	B	B1	B2	D	D1	D2	D3	D4	I	I1	I2	I3	M	H	H1	H2	WEIGHT kg
BPH 150/280.50 T	280	140	140	18	362	73	289	165	125	110	90	50	100	-	-	-	M10	254	96	158	26

## BPH 180/280.50 T - WET ROTOR CIRCULATORS

Pumped liquid temperature range: from -10 °C to +120 °C - Maximum operating pressure: 10 bar (1000 kPa)

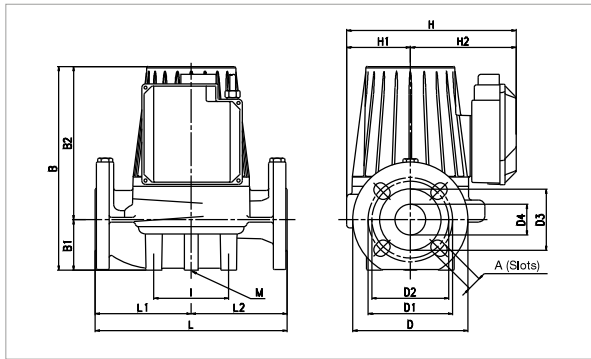

The performance curves are based on kinematic viscosity values = 1 mm<sup>2</sup>/s and density equal to 1000 kg/m<sup>3</sup>. Curve tolerance according to ISO 9906.

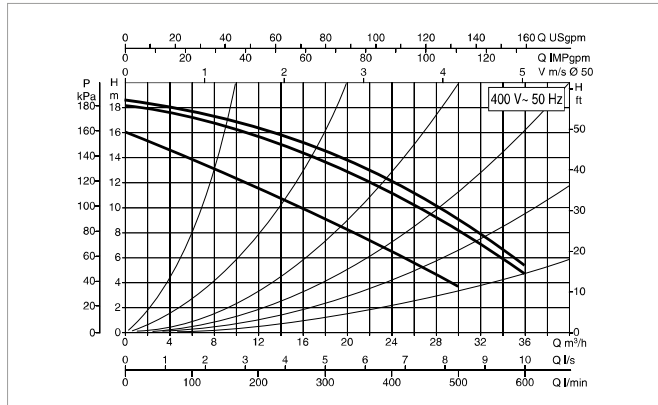

MODEL	CENTRE DISTANCE mm	COUNTERFLANGES ON REQUEST	ELECTRICAL DATA					MINIMUM SUCTION PRESSURE				
			POWER INPUT 50 Hz	SPEED	REV. 1/min	P1 MAX W	In A	t°	75°	90°	110°	120°
BPH 180/280.50 T	280	DN 50 - PN 10	3x230 V ~	2 1	2520 2340	1230 1120	3,5 3,2	m.c.w.	2	5	-	20
			3x400 V ~	3 2 1	2830 2780 2360	1630 1540 1130	3 2,70 1,85					

MODEL	L	L1	L2	A	B	B1	B2	D	D1	D2	D3	D4	I	I1	I2	I3	M	H	H1	H2	WEIGHT kg
BPH 180/280.50 T	280	140	140	18	362	73	289	165	125	110	90	50	100	-	-	-	M10	254	96	158	26

## BMH 30/340.65 T - WET ROTOR CIRCULATORS

Pumped liquid temperature range: from -10 °C to +120 °C - Maximum operating pressure: 10 bar (1000 kPa)

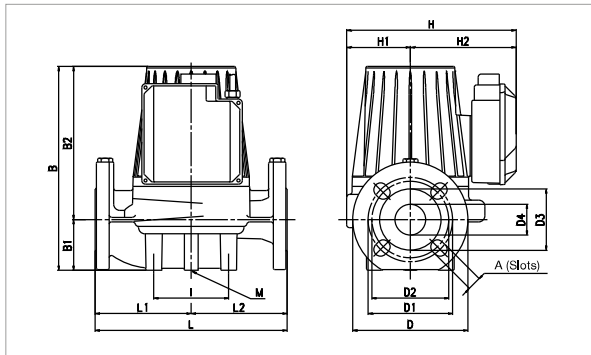

The performance curves are based on kinematic viscosity values = 1 mm<sup>2</sup>/s and density equal to 1000 kg/m<sup>3</sup>. Curve tolerance according to ISO 9906.

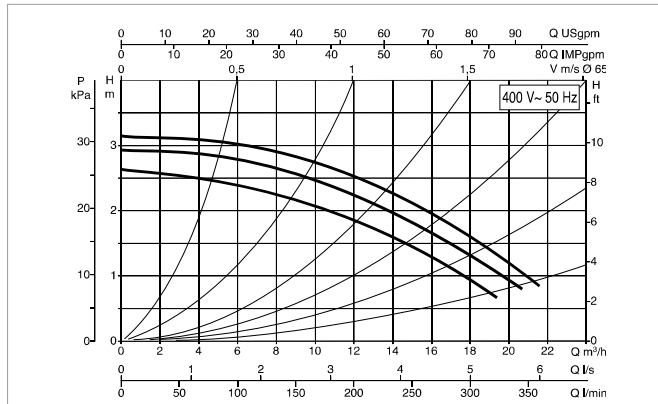

MODEL	CENTRE DISTANCE mm	COUNTERFLANGES ON REQUEST	ELECTRICAL DATA					MINIMUM SUCTION PRESSURE				
			POWER INPUT 50 Hz	SPEED	REV. 1/min	P1 MAX W	In A	t°	75°	90°	110°	120°
BMH 30/340.65 T	340	DN 65 - PN 10	3x230 V ~	2 1	1360 1310	170 154	0,73 0,60	m.c.w.	4	7,5	-	21
			3x400 V ~	3 2 1	1450 1430 1310	270 233 150	1,12 0,84 0,35					

MODEL	L	L1	L2	A	B	B1	B2	D	D1	D2	D3	D4	I	I1	I2	I3	M	H	H1	H2	WEIGHT kg
BMH 30/340.65 T	340	170	170	18	334	82	252	185	145	130	110	65	100	-	-	-	M12	259	100	159	27,5

## BMH 60/340.65 T - WET ROTOR CIRCULATORS

Pumped liquid temperature range: from -10 °C to +120 °C - Maximum operating pressure: 10 bar (1000 kPa)

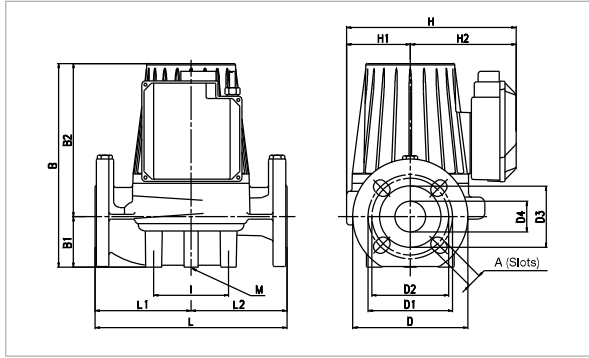

The performance curves are based on kinematic viscosity values = 1 mm<sup>2</sup>/s and density equal to 1000 kg/m<sup>3</sup>. Curve tolerance according to ISO 9906.

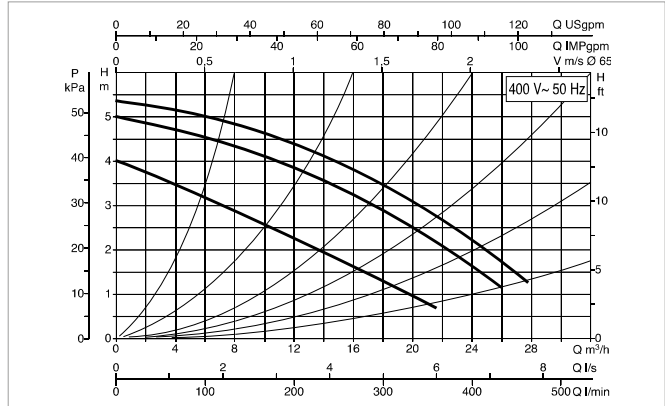

MODEL	CENTRE DISTANCE mm	COUNTERFLANGES ON REQUEST	ELECTRICAL DATA					MINIMUM SUCTION PRESSURE				
			POWER INPUT 50 Hz	SPEED	REV. 1/min	P1 MAX W	I <sub>n</sub> A	t°	75°	90°	110°	120°
								m.c.w.	4	7.5	-	21
BMH 60/340.65 T	340	DN 65 - PN 10	3x230 V ~	2 1	1170 1070	295 257	1 0.85					
			3x400 V ~	3 2 1	1380 1350 1090	445 403 255	1.2 0.97 0.49					

MODEL	L	L1	L2	A	B	B1	B2	D	D1	D2	D3	D4	I	I1	I2	I3	M	H	H1	H2	WEIGHT kg
BMH 60/340.65 T	340	170	170	18	334	82	252	185	145	130	110	65	100	-	-	-	M12	259	100	159	27,5

## BPH 60/340.65 M - WET ROTOR CIRCULATORS

Pumped liquid temperature range: from -10 °C to +110 °C - Maximum operating pressure: 10 bar (1000 kPa)

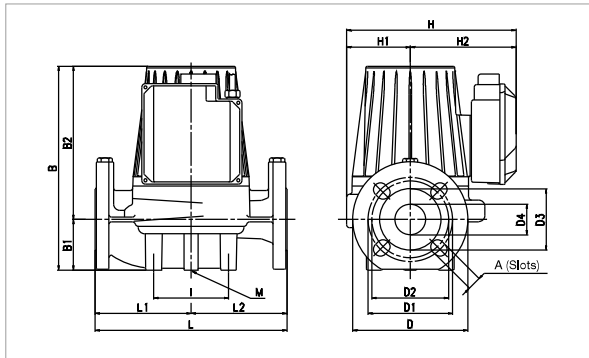

The performance curves are based on kinematic viscosity values = 1 mm<sup>2</sup>/s and density equal to 1000 kg/m<sup>3</sup>. Curve tolerance according to ISO 9906.

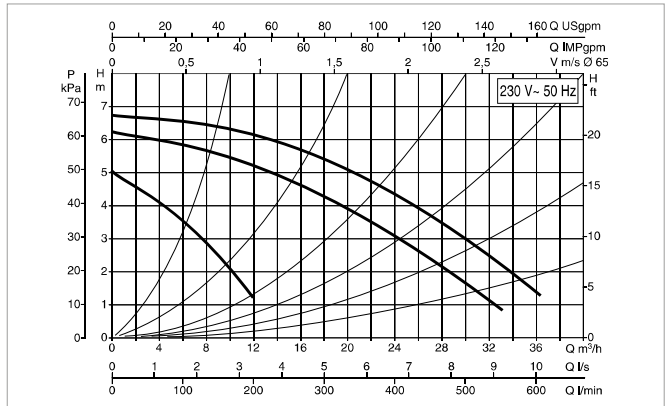

MODEL	CENTRE DISTANCE mm	COUNTERFLANGES ON REQUEST	ELECTRICAL DATA					MINIMUM SUCTION PRESSURE				
			POWER INPUT 50 Hz	SPEED	REV. 1/min	P1 MAX W	I <sub>n</sub> A	t°	75°	90°	110°	120°
								m.c.w.	1	4	13	-
BPH 60/340.65 M	340	DN 65 - PN 10	1x230 V ~	3 2 1	2780 2580 1460	735 685 564	3.37 3.13 3.12					

MODEL	L	L1	L2	A	B	B1	B2	D	D1	D2	D3	D4	I	I1	I2	I3	M	H	H1	H2	WEIGHT kg
BPH 60/340.65 M	340	170	170	18	334	82	252	185	145	130	110	65	100	-	-	-	M12	259	100	159	27,5

## BPH 60/340.65 T - WET ROTOR CIRCULATORS

Pumped liquid temperature range: from -10 °C to +120 °C - Maximum operating pressure: 10 bar (1000 kPa)

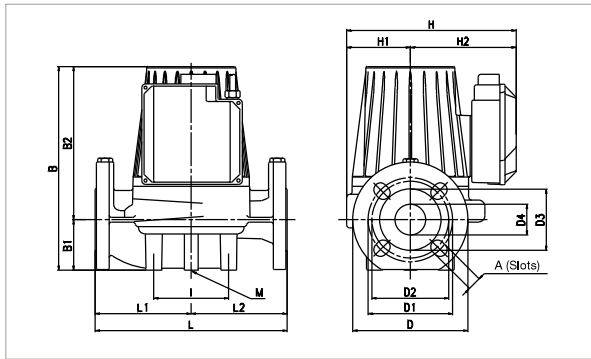

The performance curves are based on kinematic viscosity values = 1 mm<sup>2</sup>/s and density equal to 1000 kg/m<sup>3</sup>. Curve tolerance according to ISO 9906.

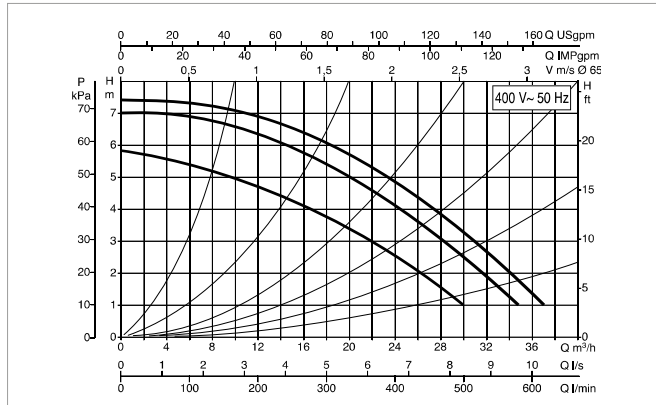

MODEL	CENTRE DISTANCE mm	COUNTERFLANGES ON REQUEST	ELECTRICAL DATA					MINIMUM SUCTION PRESSURE				
			POWER INPUT 50 Hz	SPEED	REV. 1/min	P1 MAX W	In A	t°	75°	90°	110°	120°
BPH 60/340.65 T	340	DN 65 - PN 10	3x230 V ~	2 1	2550 2380	582 532	1.67 1.53	1	4	-	18	
			3x400 V ~	3 2 1	2850 2800 2400	756 705 535	1.5 1.3 0.9					

MODEL	L	L1	L2	A	B	B1	B2	D	D1	D2	D3	D4	I	I1	I2	I3	M	H	H1	H2	WEIGHT kg
BPH 60/340.65 T	340	170	170	18	334	82	252	185	145	130	110	65	100	-	-	-	M12	259	100	159	30.5

## BPH 120/340.65 T - WET ROTOR CIRCULATORS

Pumped liquid temperature range: from -10 °C to +120 °C - Maximum operating pressure: 10 bar (1000 kPa)

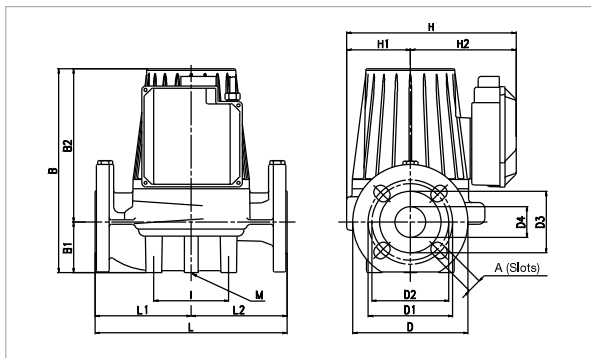

The performance curves are based on kinematic viscosity values = 1 mm<sup>2</sup>/s and density equal to 1000 kg/m<sup>3</sup>. Curve tolerance according to ISO 9906.

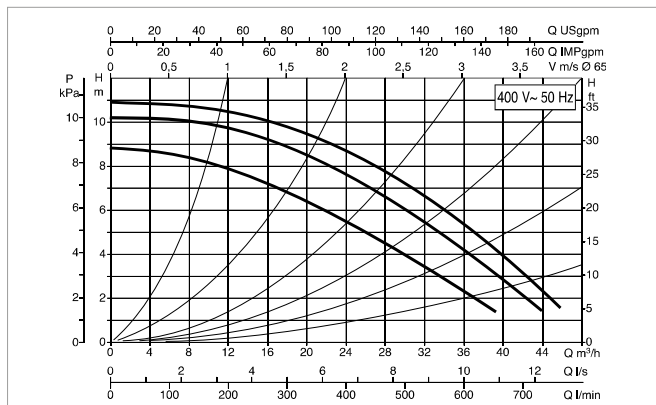

MODEL	CENTRE DISTANCE mm	COUNTERFLANGES ON REQUEST	ELECTRICAL DATA					MINIMUM SUCTION PRESSURE				
			POWER INPUT 50 Hz	SPEED	REV. 1/min	P1 MAX W	In A	t°	75°	90°	110°	120°
BPH 120/340.65 T	340	DN 65 - PN 10	3x230 V ~	2 1	2630 2500	1001 940	2.85 2.66	6	9	-	22	
			3x400 V ~	3 2 1	2880 2830 2520	1275 1200 934	2.64 2.25 1.52					

MODEL	L	L1	L2	A	B	B1	B2	D	D1	D2	D3	D4	I	I1	I2	I3	M	H	H1	H2	WEIGHT kg
BPH 120/340.65 T	340	170	170	18	384	82	302	185	145	130	110	65	100	-	-	-	M12	259	100	159	32.5

## BPH 150/340.65 T - WET ROTOR CIRCULATORS

Pumped liquid temperature range: from -10 °C to +110 °C - Maximum operating pressure: 10 bar (1000 kPa)

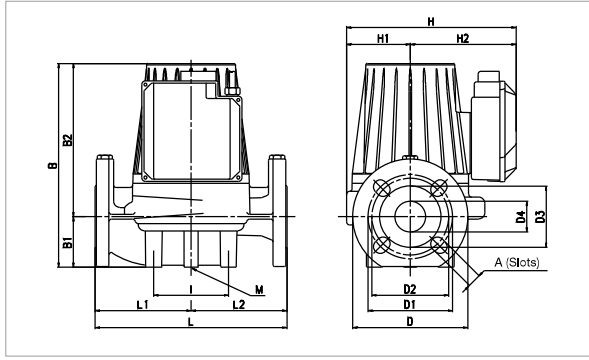

The performance curves are based on kinematic viscosity values = 1 mm<sup>2</sup>/s and density equal to 1000 kg/m<sup>3</sup>. Curve tolerance according to ISO 9906.

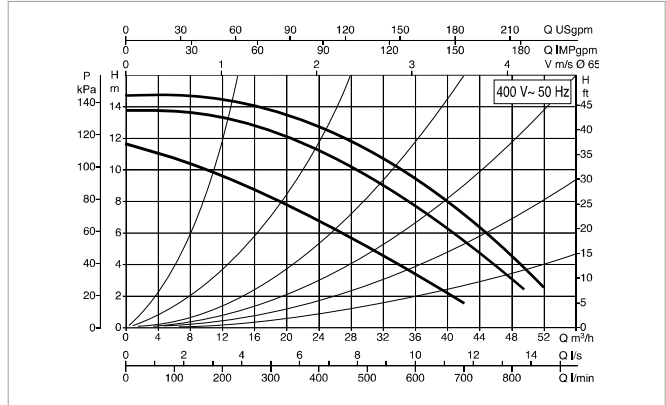

MODEL	CENTRE DISTANCE mm	COUNTERFLANGES ON REQUEST	ELECTRICAL DATA					MINIMUM SUCTION PRESSURE				
			POWER INPUT 50 Hz	SPEED	REV. 1/min	P1 MAX W	In A	t°	75°	90°	110°	120°
								m.c.w.	7	11	18	-
BPH 150/340.65 T	340	DN 65 - PN 10	3x230 V ~	2 1	2410 2250	1345 1188	3,8 3,36					
			3x400 V ~	3 2 1	2800 2730 2250	1796 1690 1210	3,25 2,93 2					

MODEL	L	L1	L2	A	B	B1	B2	D	D1	D2	D3	D4	I	I1	I2	I3	M	H	H1	H2	WEIGHT kg
BPH 150/340.65 T	340	170	170	18	384	82	302	185	145	130	110	65	100	-	-	-	M12	259	100	159	32,5

## BPH 180/340.65 T - WET ROTOR CIRCULATORS

Pumped liquid temperature range: from -10 °C to +110 °C - Maximum operating pressure: 10 bar (1000 kPa)

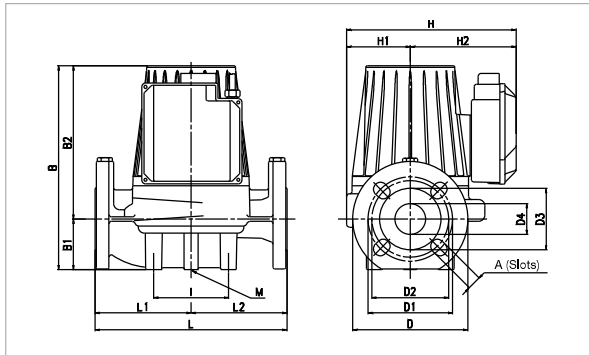

The performance curves are based on kinematic viscosity values = 1 mm<sup>2</sup>/s and density equal to 1000 kg/m<sup>3</sup>. Curve tolerance according to ISO 9906.

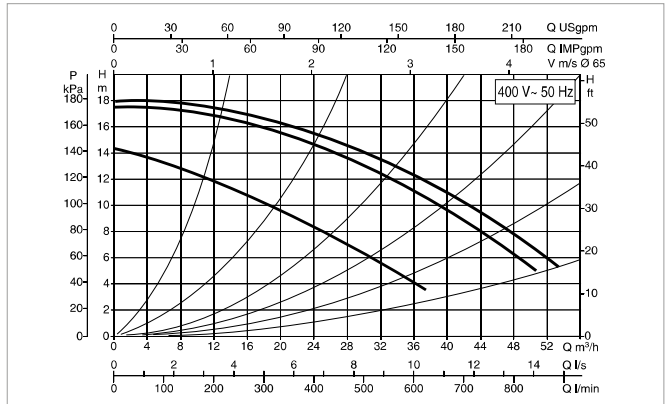

MODEL	CENTRE DISTANCE mm	COUNTERFLANGES ON REQUEST	ELECTRICAL DATA					MINIMUM SUCTION PRESSURE				
			POWER INPUT 50 Hz	SPEED	REV. 1/min	P1 MAX W	In A	t°	75°	90°	110°	120°
								m.c.w.	7	11	18	-
BPH 180/340.65 T	340	DN 65 - PN 10	3x230 V ~	2 1	2380 2170	1670 1490	4,7 4,25					
			3x400 V ~	3 2 1	2780 2700 2200	2310 2210 1490	4 3,5 2,4					

MODEL	L	L1	L2	A	B	B1	B2	D	D1	D2	D3	D4	I	I1	I2	I3	M	H	H1	H2	WEIGHT kg
BPH 180/340.65 T	340	170	170	18	384	82	302	185	145	130	110	65	100	-	-	-	M12	259	100	159	32,5

## BMH 30/360.80 T - WET ROTOR CIRCULATORS

Pumped liquid temperature range: from -10 °C to +120 °C - Maximum operating pressure: 10 bar (1000 kPa)

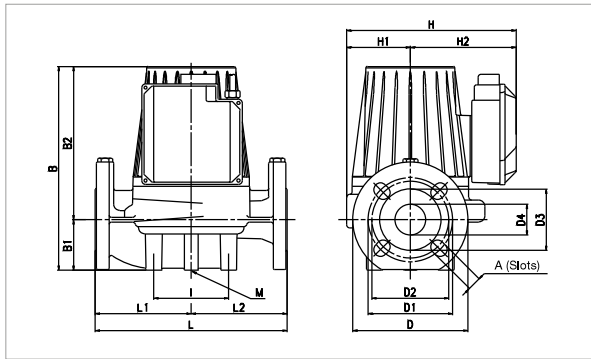

The performance curves are based on kinematic viscosity values = 1 mm<sup>2</sup>/s and density equal to 1000 kg/m<sup>3</sup>. Curve tolerance according to ISO 9906.

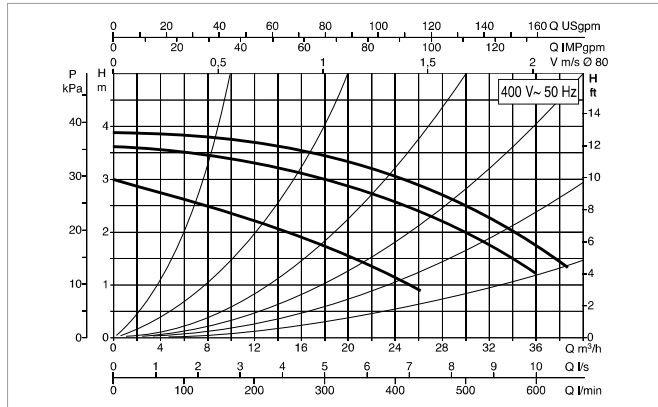

MODEL	CENTRE DISTANCE mm	COUNTERFLANGES ON REQUEST	ELECTRICAL DATA					MINIMUM SUCTION PRESSURE				
			POWER INPUT 50 Hz	SPEED	REV. 1/min	P1 MAX W	In A	t°	75°	90°	110°	120°
BMH 30/360.80 T	360	DN 80 - PN 10	3x230 V ~	2	1110	313	1,05	m.c.w.	4	7,5	-	21
			3x400 V ~	1	1010	268	0,88					
				3	1370	484	1,23					
				2	1330	437	1					
				1	1030	266	0,51					

MODEL	L	L1	L2	A	B	B1	B2	D	D1	D2	D3	D4	I	I1	I2	I3	M	H	H1	H2	WEIGHT kg
BMH 30/360.80 T	360	170	190	18	354	97	254	200	160	150	130	80	115	-	-	-	M12	297	100	159	31

## BMH 60/360.80 T - WET ROTOR CIRCULATORS

Pumped liquid temperature range: from -10 °C to +110 °C - Maximum operating pressure: 10 bar (1000 kPa)

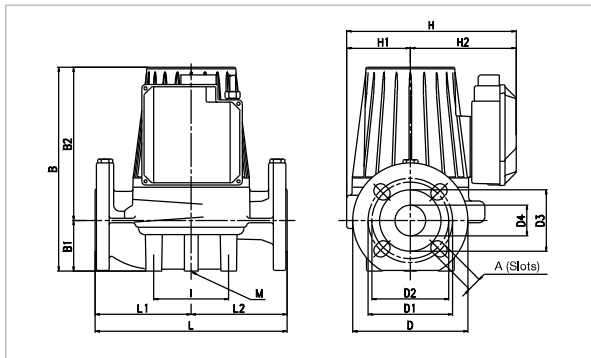

The performance curves are based on kinematic viscosity values = 1 mm<sup>2</sup>/s and density equal to 1000 kg/m<sup>3</sup>. Curve tolerance according to ISO 9906.

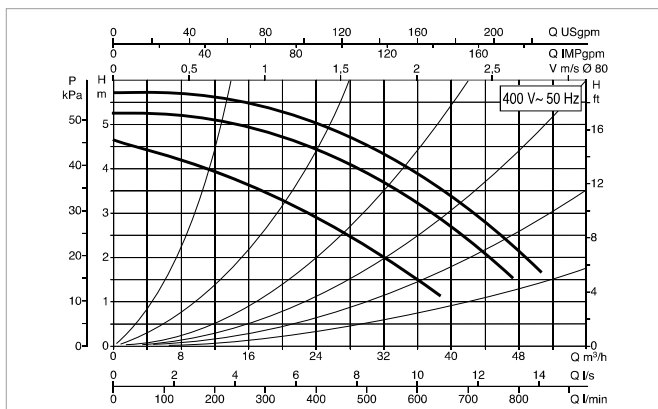

MODEL	CENTRE DISTANCE mm	COUNTERFLANGES ON REQUEST	ELECTRICAL DATA					MINIMUM SUCTION PRESSURE				
			POWER INPUT 50 Hz	SPEED	REV. 1/min	P1 MAX W	In A	t°	75°	90°	110°	120°
BMH 60/360.80 T	360	DN 80 - PN 10	3x230 V ~	2	1180	535	1,82	m.c.w.	2	5	-	20
			3x400 V ~	1	1100	465	1,55					
				3	1390	763	2,04					
				2	1350	663	1,65					
				1	1100	465	0,89					

MODEL	L	L1	L2	A	B	B1	B2	D	D1	D2	D3	D4	I	I1	I2	I3	M	H	H1	H2	WEIGHT kg
BMH 60/360.80 T	360	170	190	18	404	97	307	200	160	150	130	80	115	-	-	-	M12	259	100	159	40



## BPH 120/360.80 T - WET ROTOR CIRCULATORS

Pumped liquid temperature range: from -10 °C to +120 °C - Maximum operating pressure: 10 bar (1000 kPa)

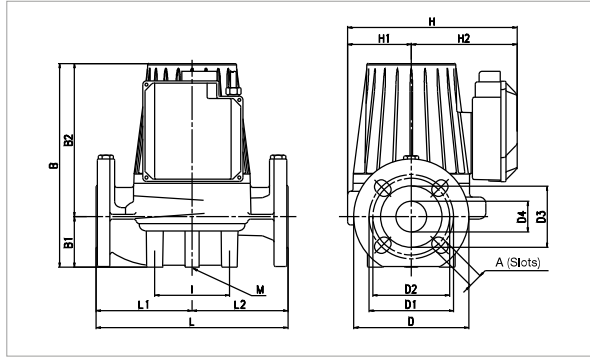

The performance curves are based on kinematic viscosity values = 1 mm<sup>2</sup>/s and density equal to 1000 kg/m<sup>3</sup>. Curve tolerance according to ISO 9906.

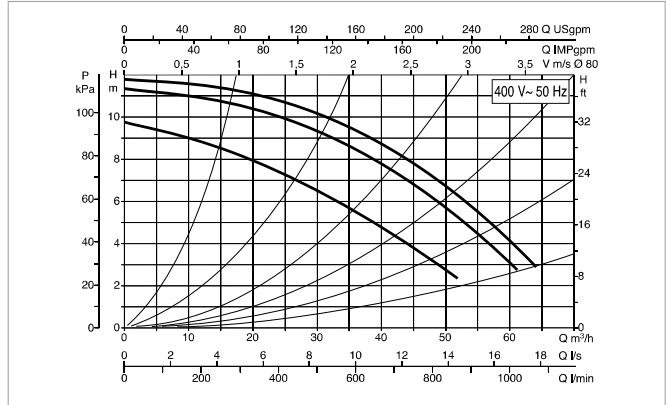

MODEL	CENTRE DISTANCE mm	COUNTERFLANGES ON REQUEST	ELECTRICAL DATA					MINIMUM SUCTION PRESSURE				
			POWER INPUT 50 Hz	SPEED	REV. 1/min	P1 MAX W	In A	t°	75°	90°	110°	120°
								m.c.w.				
BPH 120/360.80 T	360	DN 80 - PN 10	3x230 V ~	2	2500	1410	3,95	m.c.w.	6	10	-	22
				1	2340	1292	3,6					
			3x400 V ~	3	2830	1820	3,3					
				2	2780	1710	2,93					
			1	2350	1302	2,13						

MODEL	L	L1	L2	A	B	B1	B2	D	D1	D2	D3	D4	I	I1	I2	I3	M	H	H1	H2	WEIGHT kg
BPH 120/360.80 T	360	170	190	18	404	97	307	200	160	150	130	80	115	-	-	-	M12	259	100	159	40

## BPH 150/360.80 T - WET ROTOR CIRCULATORS

Pumped liquid temperature range: from -10 °C to +110 °C - Maximum operating pressure: 10 bar (1000 kPa)

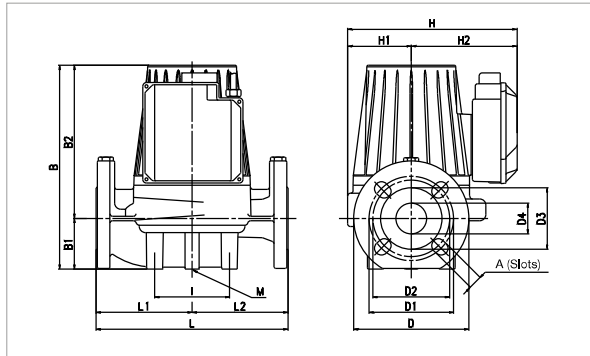

The performance curves are based on kinematic viscosity values = 1 mm<sup>2</sup>/s and density equal to 1000 kg/m<sup>3</sup>. Curve tolerance according to ISO 9906.

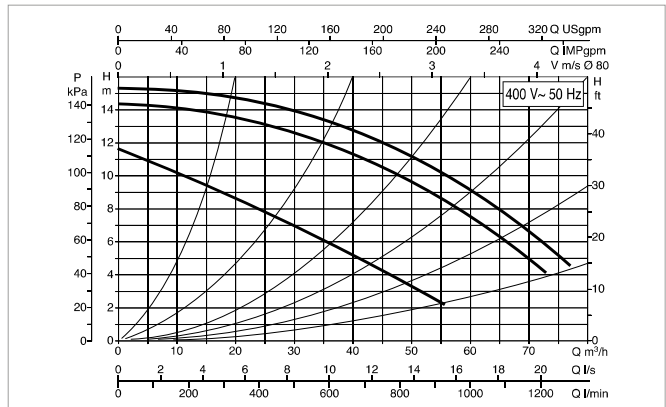

MODEL	CENTRE DISTANCE mm	COUNTERFLANGES ON REQUEST	ELECTRICAL DATA					MINIMUM SUCTION PRESSURE				
			POWER INPUT 50 Hz	SPEED	REV. 1/min	P1 MAX W	In A	t°	75°	90°	110°	120°
								m.c.w.				
BPH 150/360.80 T	360	DN 80 - PN 10	3x230 V ~	2	2140	1984	5,62	m.c.w.	7	11	18	-
				1	1900	1695	4,82					
			3x400 V ~	3	2710	2870	4,64					
				2	2610	2686	4,32					
			1	1940	1710	2,85						

MODEL	L	L1	L2	A	B	B1	B2	D	D1	D2	D3	D4	I	I1	I2	I3	M	H	H1	H2	WEIGHT kg
BPH 150/360.80 T	360	170	190	18	404	97	307	200	160	150	130	80	115	-	-	-	M12	259	100	159	40

\* model available for all markets

## BPH 180/360.80 T - WET ROTOR CIRCULATORS

Pumped liquid temperature range: from -10 °C to +110 °C - Maximum operating pressure: 10 bar (1000 kPa)

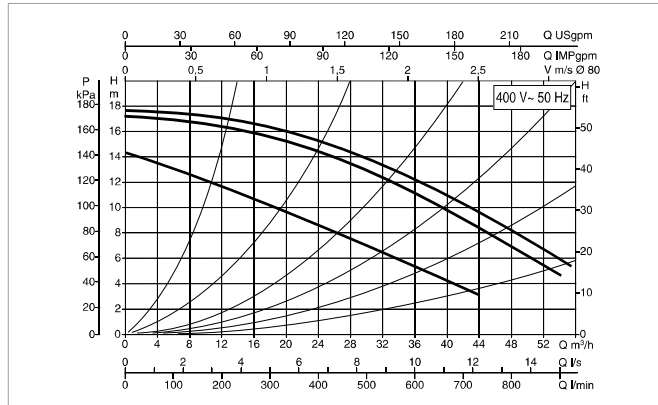
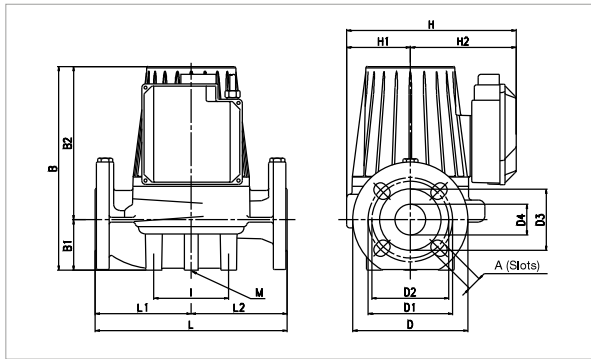

The performance curves are based on kinematic viscosity values = 1 mm²/s and density equal to 1000 kg/m³. Curve tolerance according to ISO 9906.

MODEL	CENTRE DISTANCE mm	COUNTERFLANGES ON REQUEST	ELECTRICAL DATA					MINIMUM SUCTION PRESSURE				
			POWER INPUT 50 Hz	SPEED	REV. 1/min	P1 MAX W	In A	t°	75°	90°	110°	120°
BPH 180/360.80 T	360	DN 80 - PN 10	3x230 V ~	2	2380	1670	4,7	m.c.v.	7	11	18	-
				1	2170	1490	4,25					
			3x400 V ~	3	2780	2310	4					
				2	2700	2210	3,5					
				1	2200	1490	2,4					

MODEL	L	L1	L2	A	B	B1	B2	D	D1	D2	D3	D4	I	I1	I2	I3	M	H	H1	H2	WEIGHT kg
BPH 180/360.80 T	360	170	190	18	404	97	307	200	160	150	130	80	115	-	-	-	M12	259	100	159	40

## DMH 30/250.40 T - WET ROTOR CIRCULATORS

Pumped liquid temperature range: from -10 °C to +120 °C - Maximum operating pressure: 10 bar (1000 kPa)

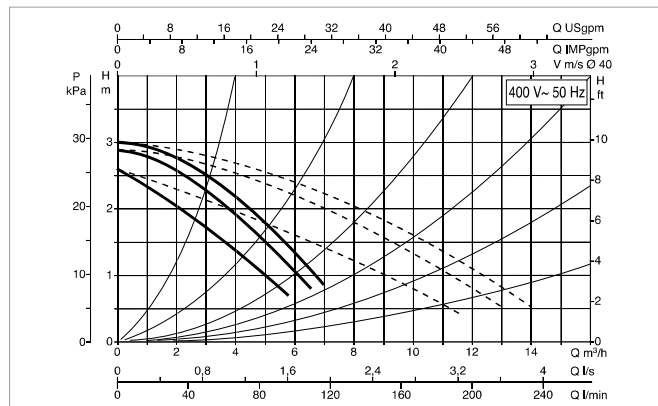
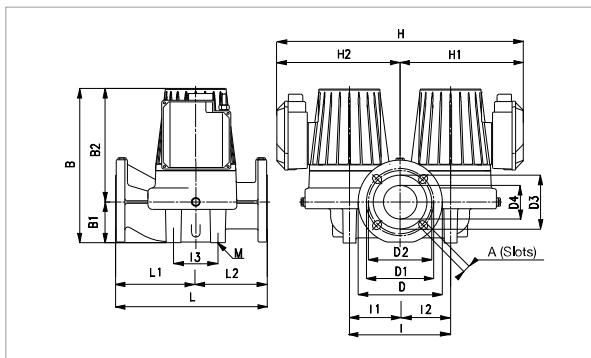

The performance curves are based on kinematic viscosity values = 1 mm²/s and density equal to 1000 kg/m³. Curve tolerance according to ISO 9906.

MODEL	CENTRE DISTANCE mm	COUNTERFLANGES ON REQUEST	ELECTRICAL DATA					MINIMUM SUCTION PRESSURE				
			POWER INPUT 50 Hz	SPEED	REV. 1/min	P1 MAX W	In A	t°	75°	90°	110°	120°
DMH 30/250.40 T	250	DN 40 - PN 10	3x230 V ~	2	1340	100	0,48	m.c.v.	0,9	4	-	18
				1	1260	88	0,39					
			3x400 V ~	3	1440	192	0,78					
				2	1430	155	0,58					
				1	1260	88	0,23					

MODEL	L	L1	L2	A	B	B1	B2	D	D1	D2	D3	D4	I	I1	I2	I3	M	H	H1	H2	WEIGHT kg
DMH 30/250.40 T	250	105	145	18	271	66	205	150	110	100	80	40	200	100	100	100	M12	476	238	238	32

## DPH 60/250.40 M - WET ROTOR CIRCULATORS

Pumped liquid temperature range: from -10 °C to +110 °C - Maximum operating pressure: 10 bar (1000 kPa)

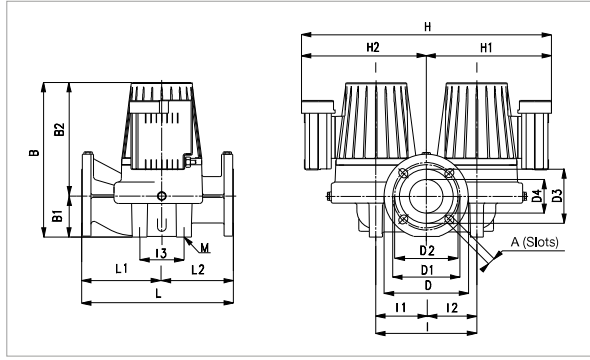

The performance curves are based on kinematic viscosity values = 1 mm<sup>2</sup>/s and density equal to 1000 kg/m<sup>3</sup>. Curve tolerance according to ISO 9906.

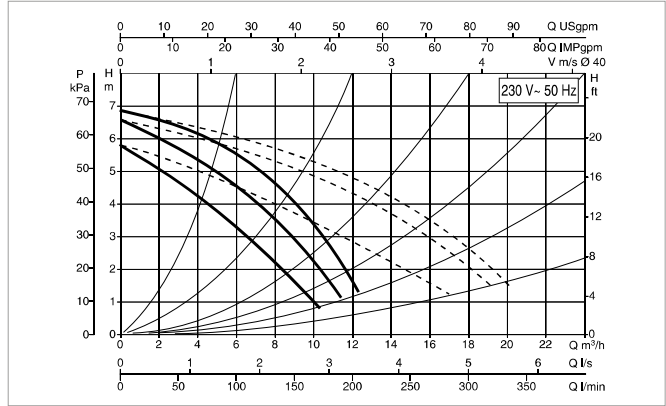

MODEL	CENTRE DISTANCE mm	COUNTERFLANGES ON REQUEST	ELECTRICAL DATA					MINIMUM SUCTION PRESSURE				
			POWER INPUT 50 Hz	SPEED	REV. 1/min	P1 MAX W	In A	t°	75°	90°	110°	120°
DPH 60/250.40 M	250	DN 40 - PN 10	1x230 V ~	3	2830	316	1.43	m.c.w.	1.6	4	14	-
				2	2750	309	1.53					
				1	2410	292	1.51					

MODEL	L	L1	L2	A	B	B1	B2	D	D1	D2	D3	D4	I	I1	I2	I3	M	H	H1	H2	WEIGHT kg
DPH 60/250.40 M	250	105	145	18	271	66	205	150	110	100	80	40	200	100	100	100	M12	476	238	238	32

## DPH 60/250.40 T - WET ROTOR CIRCULATORS

Pumped liquid temperature range: from -10 °C to +120 °C - Maximum operating pressure: 10 bar (1000 kPa)

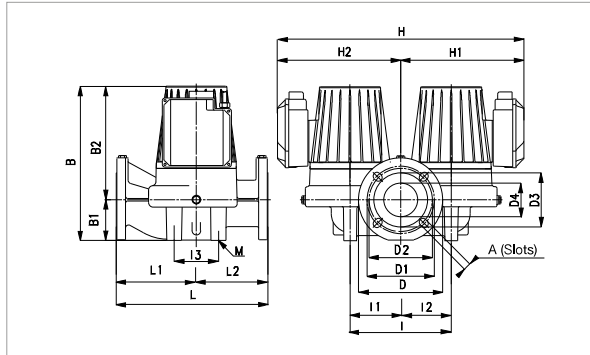

The performance curves are based on kinematic viscosity values = 1 mm<sup>2</sup>/s and density equal to 1000 kg/m<sup>3</sup>. Curve tolerance according to ISO 9906.

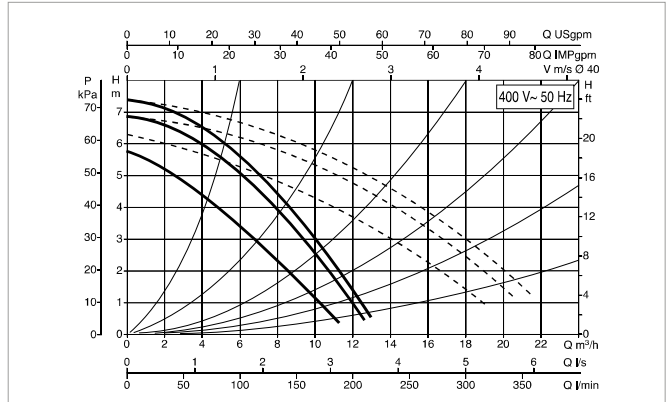

MODEL	CENTRE DISTANCE mm	COUNTERFLANGES ON REQUEST	ELECTRICAL DATA					MINIMUM SUCTION PRESSURE				
			POWER INPUT 50 Hz	SPEED	REV. 1/min	P1 MAX W	In A	t°	75°	90°	110°	120°
DPH 60/250.40 T	250	DN 40 - PN 10	3x230 V ~	2	2570	253	0.81	m.c.w.	1.6	4	-	19
				1	2420	229	0.72					
				3	2850	348	0.99					
			3x400 V ~	2	2810	316	0.75					
				1	2430	232	0.42					

MODEL	L	L1	L2	A	B	B1	B2	D	D1	D2	D3	D4	I	I1	I2	I3	M	H	H1	H2	WEIGHT kg
DPH 60/250.40 T	250	105	145	18	271	66	205	150	110	100	80	40	200	100	100	100	M12	476	238	238	32

## DPH 120/250.40 M - WET ROTOR CIRCULATORS

Pumped liquid temperature range: from -10 °C to +110 °C - Maximum operating pressure: 10 bar (1000 kPa)

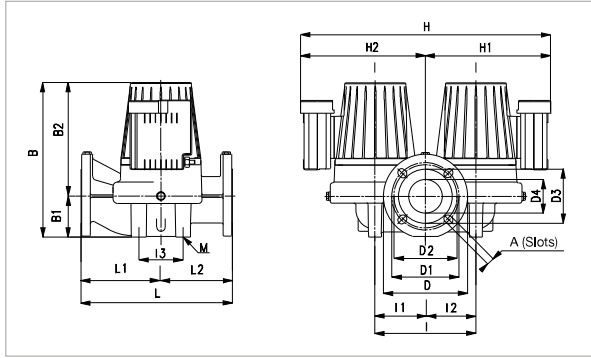

The performance curves are based on kinematic viscosity values = 1 mm<sup>2</sup>/s and density equal to 1000 kg/m<sup>3</sup>. Curve tolerance according to ISO 9906.

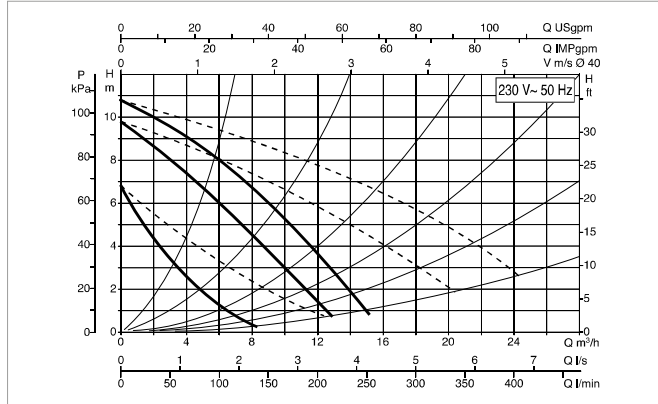

MODEL	CENTRE DISTANCE mm	COUNTERFLANGES ON REQUEST	ELECTRICAL DATA					MINIMUM SUCTION PRESSURE				
			POWER INPUT 50 Hz	SPEED	REV. 1/min	P1 MAX W	In A	t°	75°	90°	110°	120°
DPH 120/250.40 M	250	DN 40 - PN 10	1x230 V ~	3	2650	510	2.24	m.c.w.	6	9	18	-
				2	2320	498	2.35					
				1	1520	376	1.96					

MODEL	L	L1	L2	A	B	B1	B2	D	D1	D2	D3	D4	I	I1	I2	I3	M	H	H1	H2	WEIGHT kg
DPH 120/250.40 M	250	105	145	18	271	66	205	150	110	100	80	40	200	100	100	100	M12	476	238	238	32

## DPH 120/250.40 T - WET ROTOR CIRCULATORS

Pumped liquid temperature range: from -10 °C to +120 °C - Maximum operating pressure: 10 bar (1000 kPa)

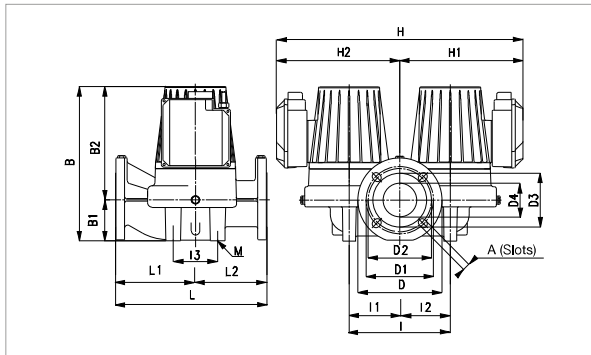

The performance curves are based on kinematic viscosity values = 1 mm<sup>2</sup>/s and density equal to 1000 kg/m<sup>3</sup>. Curve tolerance according to ISO 9906.

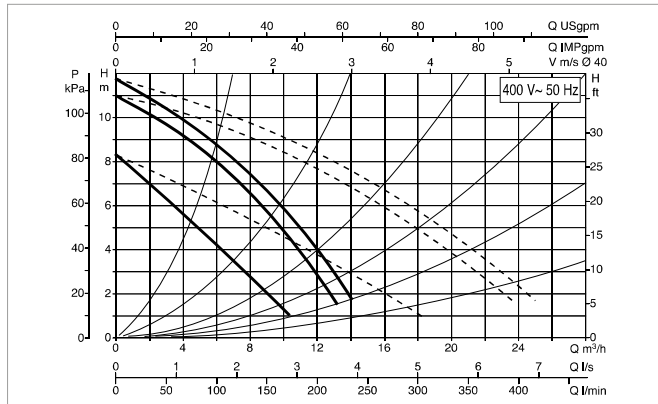

MODEL	CENTRE DISTANCE mm	COUNTERFLANGES ON REQUEST	ELECTRICAL DATA					MINIMUM SUCTION PRESSURE				
			POWER INPUT 50 Hz	SPEED	REV. 1/min	P1 MAX W	In A	t°	75°	90°	110°	120°
DPH 120/250.40 T	250	DN 40 - PN 10	3x230 V ~	2	2300	395	1.2	m.c.w.	6	9	-	23
				1	2070	340	1.07					
				3	2780	536	1.16					
			3x400 V ~	2	2710	499	0.98					
				2	2080	339	0.62					
				1								

MODEL	L	L1	L2	A	B	B1	B2	D	D1	D2	D3	D4	I	I1	I2	I3	M	H	H1	H2	WEIGHT kg
DPH 120/250.40 T	250	105	145	18	271	66	205	150	110	100	80	40	200	100	100	100	M12	476	238	238	32

## DMH 30/280.50 T - WET ROTOR CIRCULATORS

Pumped liquid temperature range: from -10 °C to +120 °C - Maximum operating pressure: 10 bar (1000 kPa)

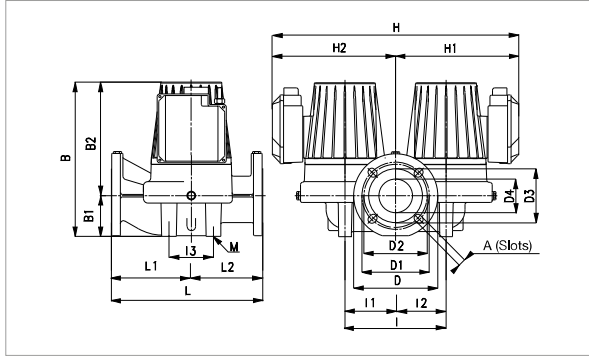

The performance curves are based on kinematic viscosity values = 1 mm<sup>2</sup>/s and density equal to 1000 kg/m<sup>3</sup>. Curve tolerance according to ISO 9906.

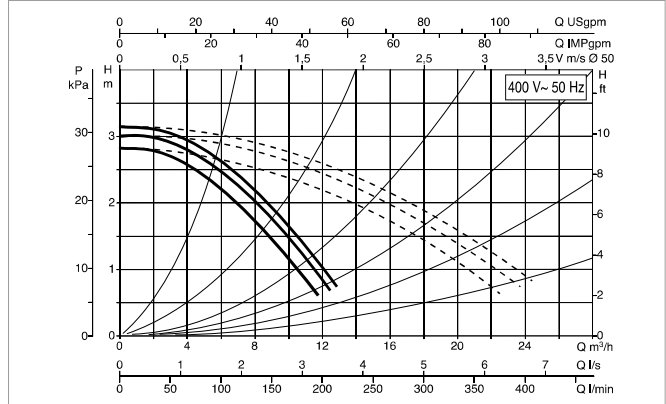

MODEL	CENTRE DISTANCE mm	COUNTERFLANGES ON REQUEST	ELECTRICAL DATA					MINIMUM SUCTION PRESSURE				
			POWER INPUT 50 Hz	SPEED	REV. 1/min	P1 MAX W	In A	t°	75°	90°	110°	120°
DMH 30/280.50 T	280	DN 50 - PN 10	3x230 V ~	2 1	1390 1340	148 134	0,7 0,55	m.c.w.	0,9	4	-	18
			3x400 V ~	3 2 1	1460 1450 1350	255 216 131	1,12 0,83 0,32					

MODEL	L	L1	L2	A	B	B1	B2	D	D1	D2	D3	D4	I	I1	I2	I3	M	H	H1	H2	WEIGHT kg
DMH 30/280.50 T	280	130	150	18	305	73	232	165	125	110	90	50	240	120	120	120	M14	552	276	276	51,5

## DMH 60/280.50 T - WET ROTOR CIRCULATORS

Pumped liquid temperature range: from -10 °C to +120 °C - Maximum operating pressure: 10 bar (1000 kPa)

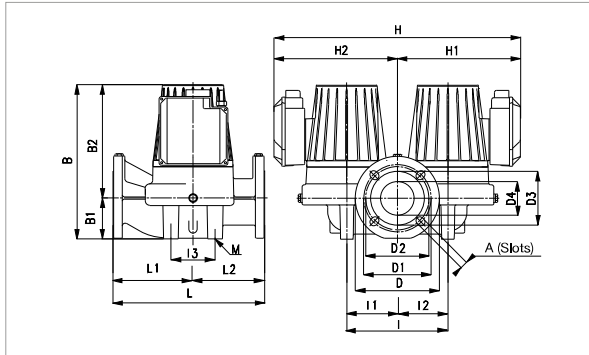

The performance curves are based on kinematic viscosity values = 1 mm<sup>2</sup>/s and density equal to 1000 kg/m<sup>3</sup>. Curve tolerance according to ISO 9906.

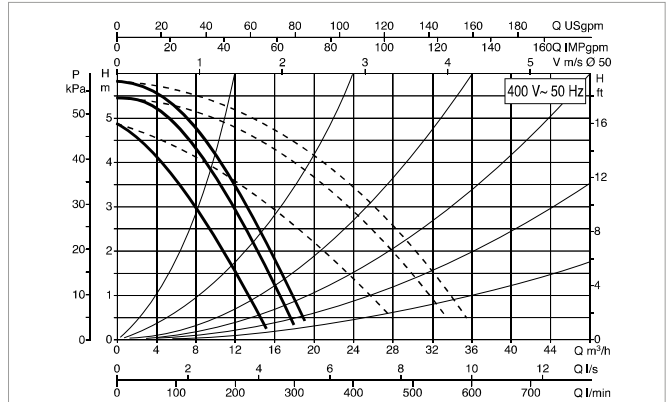

MODEL	CENTRE DISTANCE mm	COUNTERFLANGES ON REQUEST	ELECTRICAL DATA					MINIMUM SUCTION PRESSURE				
			POWER INPUT 50 Hz	SPEED	REV. 1/min	P1 MAX W	In A	t°	75°	90°	110°	120°
DMH 60/280.50 T	280	DN 50 - PN 10	3x230 V ~	2 1	1210 1120	272 240	0,94 0,8	m.c.w.	4	7,5	-	21
			3x400 V ~	3 2 1	1400 1360 1130	410 367 235	1,2 0,95 0,46					

MODEL	L	L1	L2	A	B	B1	B2	D	D1	D2	D3	D4	I	I1	I2	I3	M	H	H1	H2	WEIGHT kg
DMH 60/280.50 T	280	130	150	18	308	73	235	165	125	110	90	50	240	120	120	120	M14	556	278	278	44,5

## DPH 60/280.50 M - WET ROTOR CIRCULATORS

Pumped liquid temperature range: from -10 °C to +120 °C - Maximum operating pressure: 10 bar (1000 kPa)

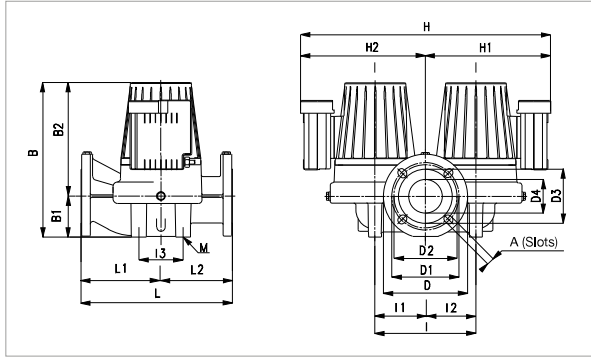

The performance curves are based on kinematic viscosity values = 1 mm<sup>2</sup>/s and density equal to 1000 kg/m<sup>3</sup>. Curve tolerance according to ISO 9906.

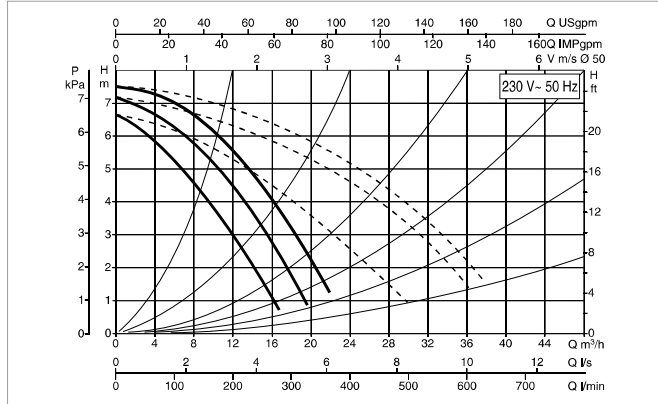

MODEL	CENTRE DISTANCE mm	COUNTERFLANGES ON REQUEST	ELECTRICAL DATA					MINIMUM SUCTION PRESSURE				
			POWER INPUT 50 Hz	SPEED	REV. 1/min	P1 MAX W	In A	t°	75°	90°	110°	120°
DPH 60/280.50 M	280	DN 50 - PN 10	1x230 V ~	3	2840	595	2.79	m.c.w.	1.6	6	14	-
				2	2730	540	2.45					
				1	2200	506	2.58					

MODEL	L	L1	L2	A	B	B1	B2	D	D1	D2	D3	D4	I	I1	I2	I3	M	H	H1	H2	WEIGHT kg
DPH 60/280.50 M	280	130	150	18	308	73	235	165	125	110	90	50	240	120	120	120	M14	554	278	278	44,5

## DPH 60/280.50 T - WET ROTOR CIRCULATORS

Pumped liquid temperature range: from -10 °C to +120 °C - Maximum operating pressure: 10 bar (1000 kPa)

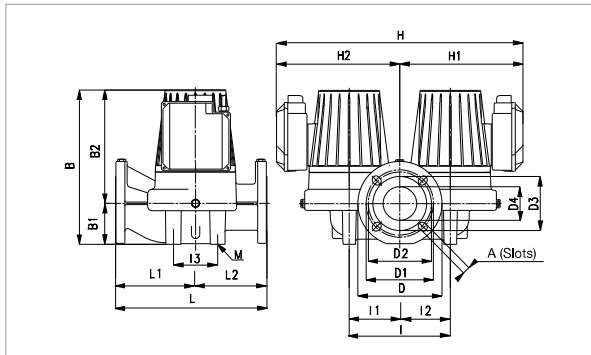

The performance curves are based on kinematic viscosity values = 1 mm<sup>2</sup>/s and density equal to 1000 kg/m<sup>3</sup>. Curve tolerance according to ISO 9906.

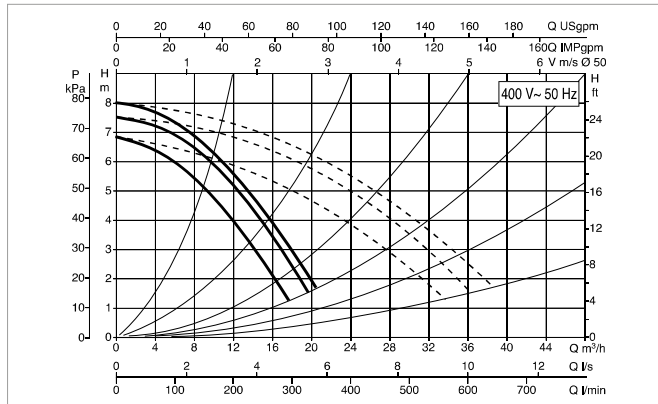

MODEL	CENTRE DISTANCE mm	COUNTERFLANGES ON REQUEST	ELECTRICAL DATA					MINIMUM SUCTION PRESSURE				
			POWER INPUT 50 Hz	SPEED	REV. 1/min	P1 MAX W	In A	t°	75°	90°	110°	120°
DPH 60/280.50 T	280	DN 50 - PN 10	3x230 V ~	2	2670	464	1.35	m.c.w.	1.6	6	-	19
				1	2570	432	1.23					
			3x400 V ~	3	2890	589	1.31					
				2	2860	546	1.1					
			1	2570	423	0.71						

MODEL	L	L1	L2	A	B	B1	B2	D	D1	D2	D3	D4	I	I1	I2	I3	M	H	H1	H2	WEIGHT kg
DPH 60/280.50 T	280	130	150	18	308	73	235	165	125	110	90	50	240	120	120	120	M14	554	278	278	44,5

## DPH 120/280.50 M - WET ROTOR CIRCULATORS

Pumped liquid temperature range: from -10 °C to +90 °C - Maximum operating pressure: 10 bar (1000 kPa)

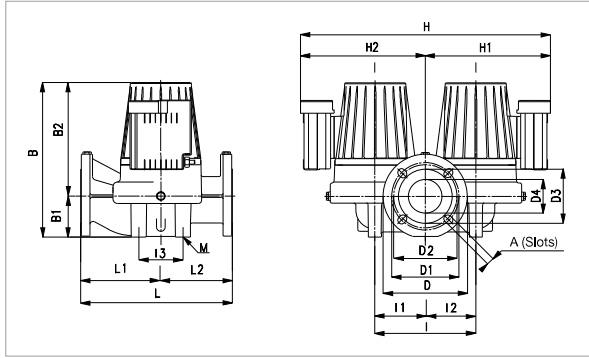

The performance curves are based on kinematic viscosity values = 1 mm<sup>2</sup>/s and density equal to 1000 kg/m<sup>3</sup>. Curve tolerance according to ISO 9906.

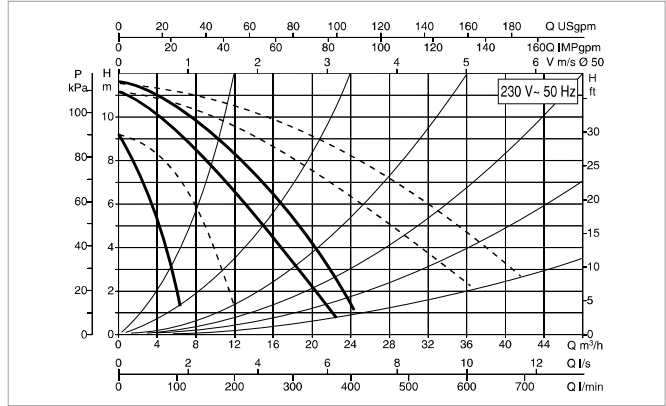

MODEL	CENTRE DISTANCE mm	COUNTERFLANGES ON REQUEST	ELECTRICAL DATA					MINIMUM SUCTION PRESSURE					
			POWER INPUT 50 Hz	SPEED	REV. 1/min	P1 MAX W	In A	t°	75°	90°	110°	120°	
DPH 120/280.50 M	280	DN 50 - PN 10	1x230 V ~	3	3	2690	870	3,97	m.c.w.	2	5	-	20
				2	2	2360	800	3,69					
				1	1	1340	590	3,12					

MODEL	L	L1	L2	A	B	B1	B2	D	D1	D2	D3	D4	I	I1	I2	I3	M	H	H1	H2	WEIGHT kg
DPH 120/280.50 M	280	130	150	18	308	73	235	165	125	110	90	50	240	120	120	120	M14	556	278	278	44,5

## DPH 120/280.50 T - WET ROTOR CIRCULATORS

Pumped liquid temperature range: from -10 °C to +120 °C - Maximum operating pressure: 10 bar (1000 kPa)

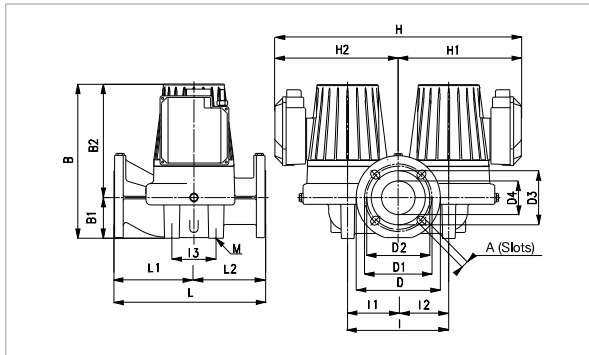

The performance curves are based on kinematic viscosity values = 1 mm<sup>2</sup>/s and density equal to 1000 kg/m<sup>3</sup>. Curve tolerance according to ISO 9906.

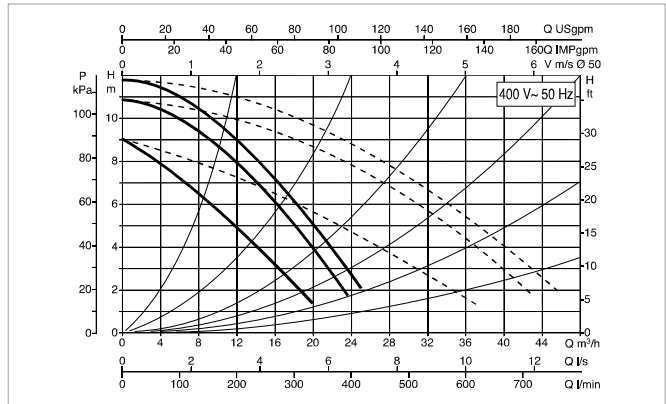

MODEL	CENTRE DISTANCE mm	COUNTERFLANGES ON REQUEST	ELECTRICAL DATA					MINIMUM SUCTION PRESSURE					
			POWER INPUT 50 Hz	SPEED	REV. 1/min	P1 MAX W	In A	t°	75°	90°	110°	120°	
DPH 120/280.50 T	280	DN 50 - PN 10	3x230 V ~	2	2	2430	683	1,95	m.c.w.	2	5	-	20
				1	1	2240	605	1,75					
				3	3	2810	898	1,67					
			3x400 V ~	2	2	2740	840	1,47					
				1	1	2260	603	1					

MODEL	L	L1	L2	A	B	B1	B2	D	D1	D2	D3	D4	I	I1	I2	I3	M	H	H1	H2	WEIGHT kg
DPH 120/280.50 T	280	130	150	18	308	73	235	165	125	110	90	50	240	120	120	120	M14	556	278	278	49

## DPH 150/280.50 T - WET ROTOR CIRCULATORS

Pumped liquid temperature range: from -10 °C to +110 °C - Maximum operating pressure: 10 bar (1000 kPa)

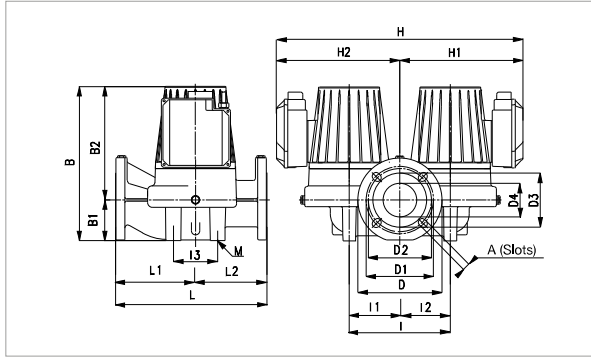

The performance curves are based on kinematic viscosity values = 1 mm<sup>2</sup>/s and density equal to 1000 kg/m<sup>3</sup>. Curve tolerance according to ISO 9906.

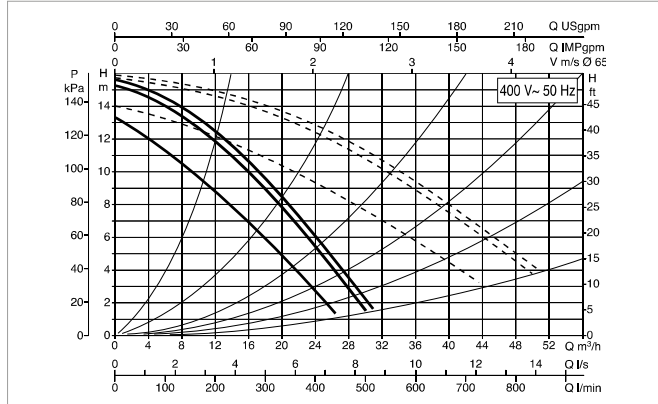

MODEL	CENTRE DISTANCE mm	COUNTERFLANGES ON REQUEST	ELECTRICAL DATA					MINIMUM SUCTION PRESSURE				
			POWER INPUT 50 Hz	SPEED	REV. 1/min	P1 MAX W	In A	t°	75°	90°	110°	120°
DPH 150/280.50 T	280	DN 50 - PN 10	3x230 V ~	2	2553	1130	3,22	m.c.w.	2	5	-	20
			1	2420	1032	3						
			3x400 V ~	3	2850	1470	2,9					
			2	2802	1360	2,5						
			1	2425	1030	1,7						

MODEL	L	L1	L2	A	B	B1	B2	D	D1	D2	D3	D4	I	I1	I2	I3	M	H	H1	H2	WEIGHT kg
DPH 150/280.50 T	280	130	150	18	358	73	285	165	125	110	90	50	240	120	120	120	M14	556	278	278	49

## DPH 180/280.50 T - WET ROTOR CIRCULATORS

Pumped liquid temperature range: from -10 °C to +110 °C - Maximum operating pressure: 10 bar (1000 kPa)

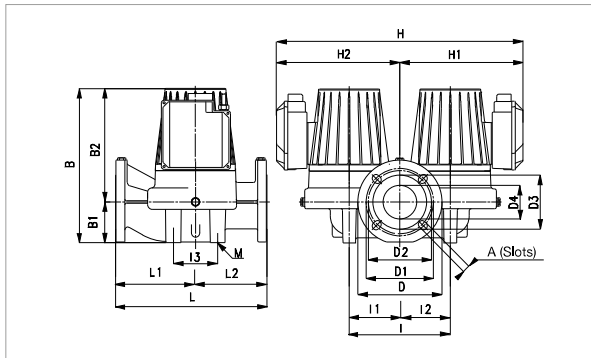

The performance curves are based on kinematic viscosity values = 1 mm<sup>2</sup>/s and density equal to 1000 kg/m<sup>3</sup>. Curve tolerance according to ISO 9906.

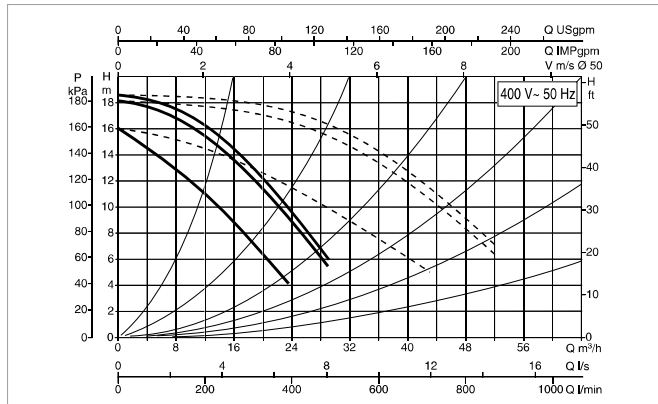

MODEL	CENTRE DISTANCE mm	COUNTERFLANGES ON REQUEST	ELECTRICAL DATA					MINIMUM SUCTION PRESSURE				
			POWER INPUT 50 Hz	SPEED	REV. 1/min	P1 MAX W	In A	t°	75°	90°	110°	120°
DPH 180/280.50 T	280	DN 50 - PN 10	3x230 V ~	2	2520	1230	3,5	m.c.w.	2	5	-	20
			1	2340	1120	3,2						
			3x400 V ~	3	2830	1630	3					
			2	2780	1540	2,70						
			1	2360	1130	1,85						

MODEL	L	L1	L2	A	B	B1	B2	D	D1	D2	D3	D4	I	I1	I2	I3	M	H	H1	H2	WEIGHT kg
DPH 180/280.50 T	280	130	150	18	358	73	285	165	125	110	90	50	240	120	120	120	M14	556	278	278	49



## DMH 30/340.65 T- WET ROTOR CIRCULATORS

Pumped liquid temperature range: from -10 °C to +120 °C - Maximum operating pressure: 10 bar (1000 kPa)

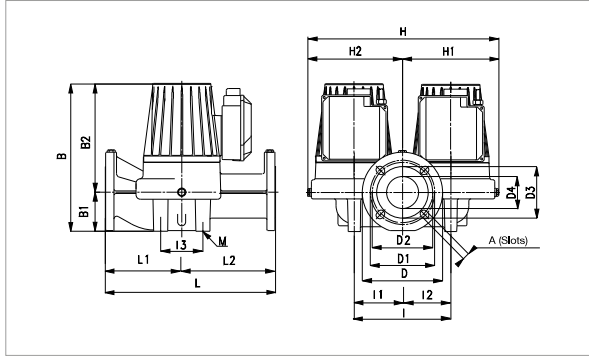

The performance curves are based on kinematic viscosity values = 1 mm<sup>2</sup>/s and density equal to 1000 kg/m<sup>3</sup>. Curve tolerance according to ISO 9906.

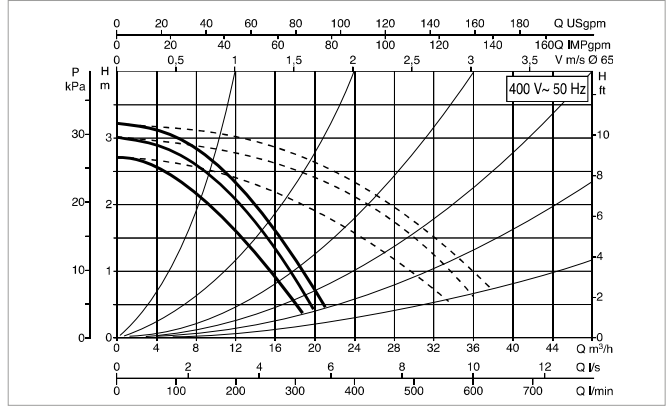

MODEL	CENTRE DISTANCE mm	COUNTERFLANGES ON REQUEST	ELECTRICAL DATA				MINIMUM SUCTION PRESSURE					
			POWER INPUT 50 Hz	SPEED	REV. 1/min	P1 MAX W	In A	t°	75°	90°	110°	120°
DMH 30/340.65 T	340	DN 65 - PN 10	3x230 V ~	2 1	1360 1310	170 154	0,73 0,60	m.c.w.	4	7,5	-	21
			3x400 V ~	3 2 1	1450 1430 1310	270 233 150	1,12 0,84 0,35					

MODEL	L	L1	L2	A	B	B1	B2	D	D1	D2	D3	D4	I	I1	I2	I3	M	H	H1	H2	WEIGHT kg
DMH 30/340.65 T	340	138,5	201,5	18	328	82	246	185	145	130	110	65	240	120	120	120	M14	476	238	238	57

## DMH 60/340.65 T - WET ROTOR CIRCULATORS

Pumped liquid temperature range: from -10 °C to +120 °C - Maximum operating pressure: 10 bar (1000 kPa)

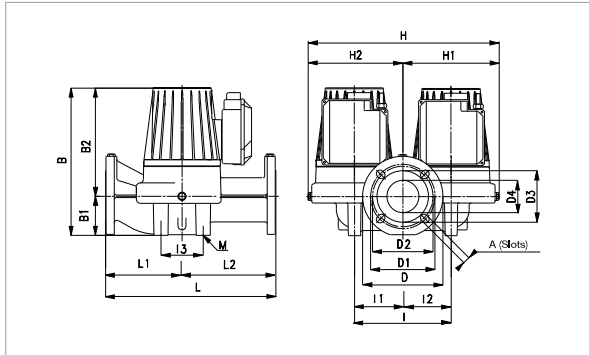

The performance curves are based on kinematic viscosity values = 1 mm<sup>2</sup>/s and density equal to 1000 kg/m<sup>3</sup>. Curve tolerance according to ISO 9906.

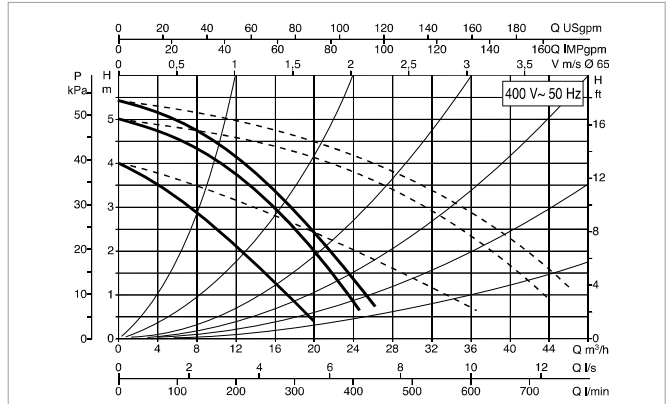

MODEL	CENTRE DISTANCE mm	COUNTERFLANGES ON REQUEST	ELECTRICAL DATA				MINIMUM SUCTION PRESSURE					
			POWER INPUT 50 Hz	SPEED	REV. 1/min	P1 MAX W	In A	t°	75°	90°	110°	120°
DMH 60/340.65 T	340	DN 65 - PN 10	3x230 V ~	2 1	1170 1070	295 257	1 0,85	m.c.w.	4	7,5	-	21
			3x400 V ~	3 2 1	1380 1350 1090	445 403 255	1,2 0,97 0,49					

MODEL	L	L1	L2	A	B	B1	B2	D	D1	D2	D3	D4	I	I1	I2	I3	M	H	H1	H2	WEIGHT kg
DMH 60/340.65 T	340	138,5	201,5	18	331	82	249	185	145	130	110	65	240	120	120	120	M14	476	238	238	50

## DPH 60/340.65 M - WET ROTOR CIRCULATORS

Pumped liquid temperature range: from -10 °C to +110 °C - Maximum operating pressure: 10 bar (1000 kPa)

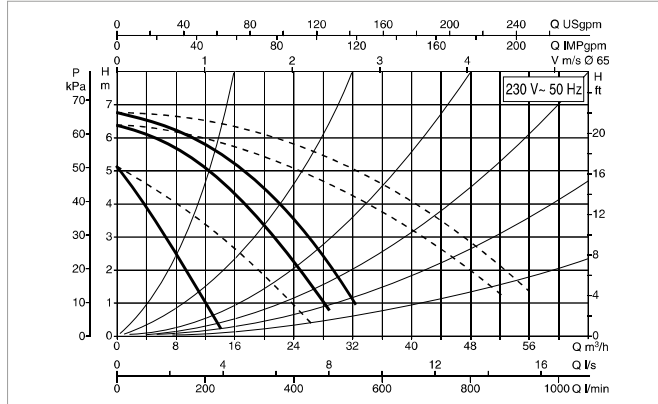
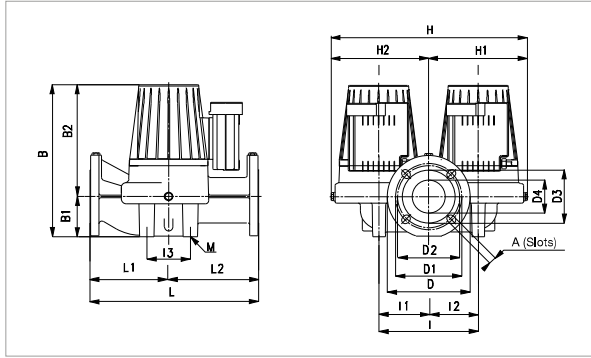

The performance curves are based on kinematic viscosity values = 1 mm<sup>2</sup>/s and density equal to 1000 kg/m<sup>3</sup>. Curve tolerance according to ISO 9906.

MODEL	CENTRE DISTANCE mm	COUNTERFLANGES ON REQUEST	ELECTRICAL DATA					MINIMUM SUCTION PRESSURE				
			POWER INPUT 50 Hz	SPEED	REV. 1/min	P1 MAX W	In A	t°	75°	90°	110°	120°
DPH 60/340.65 M	340	DN 65 - PN 10	1x230 V ~	3	2780	735	3.37	m.c.w.	1	4	13	-
				2	2580	685	3.13					
				1	1460	564	3.12					

MODEL	L	L1	L2	A	B	B1	B2	D	D1	D2	D3	D4	I	I1	I2	I3	M	H	H1	H2	WEIGHT kg
DPH 60/340.65 M	340	138,5	201,5	18	331	82	249	185	145	130	110	65	240	120	120	140	M14	476	238	238	50

## DPH 60/340.65 T - WET ROTOR CIRCULATORS

Pumped liquid temperature range: from -10 °C to +120 °C - Maximum operating pressure: 10 bar (1000 kPa)

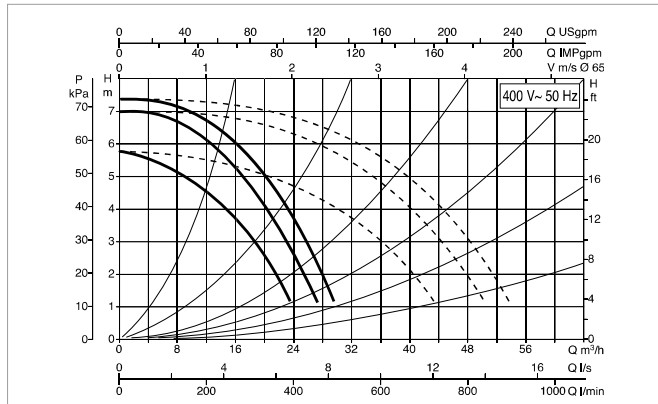
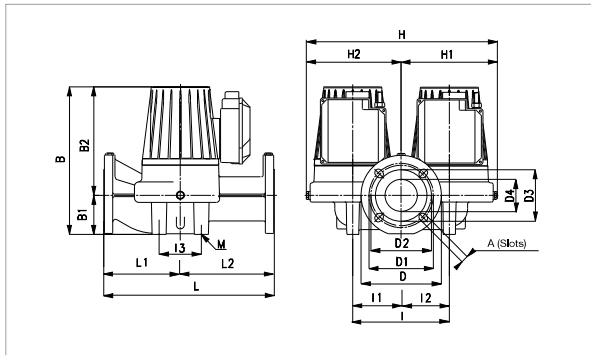

The performance curves are based on kinematic viscosity values = 1 mm<sup>2</sup>/s and density equal to 1000 kg/m<sup>3</sup>. Curve tolerance according to ISO 9906.

MODEL	CENTRE DISTANCE mm	COUNTERFLANGES ON REQUEST	ELECTRICAL DATA					MINIMUM SUCTION PRESSURE				
			POWER INPUT 50 Hz	SPEED	REV. 1/min	P1 MAX W	In A	t°	75°	90°	110°	120°
DPH 60/340.65 T	340	DN 65 - PN 10	3x230 V ~	2	2550	582	1,67	m.c.w.	1	4	-	18
				1	2380	532	1,53					
				3	2850	756	1,5					
			3x400 V ~	2	2800	705	1,3					
				1	2400	535	0,9					

MODEL	L	L1	L2	A	B	B1	B2	D	D1	D2	D3	D4	I	I1	I2	I3	M	H	H1	H2	WEIGHT kg
DPH 60/340.65 T	340	138,5	201,5	18	331	82	249	185	145	130	110	65	240	120	120	140	M14	476	238	238	54,5

## DPH 120/340.65 T - WET ROTOR CIRCULATORS

Pumped liquid temperature range: from -10 °C to +110 °C - Maximum operating pressure: 10 bar (1000 kPa)

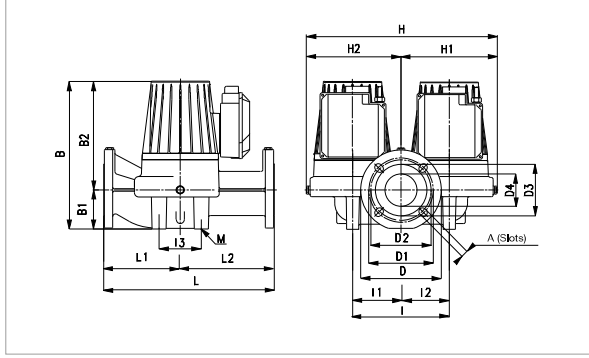

The performance curves are based on kinematic viscosity values = 1 mm<sup>2</sup>/s and density equal to 1000 kg/m<sup>3</sup>. Curve tolerance according to ISO 9906.

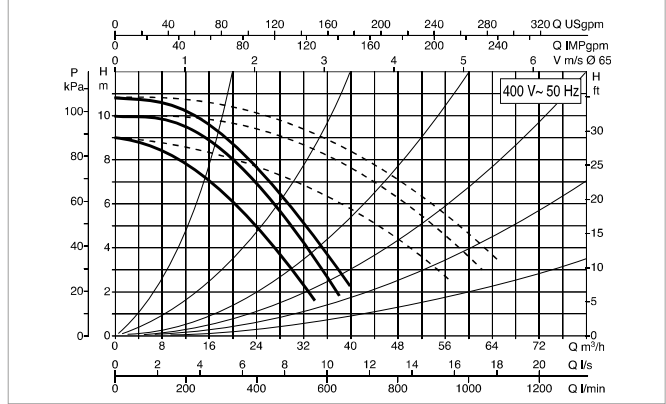

MODEL	CENTRE DISTANCE mm	COUNTERFLANGES ON REQUEST	ELECTRICAL DATA					MINIMUM SUCTION PRESSURE				
			POWER INPUT 50 Hz	SPEED	REV. 1/min	P1 MAX W	In A	t°	75°	90°	110°	120°
DPH 120/340.65 T	340	DN 65 - PN 10	3x230 V ~	2 1	2630 2500	1001 940	2,85 2,66	m.c.w.	6	9	-	22
			3x400 V ~	3 2 1	2880 2830 2520	1275 1200 934	2,64 2,25 1,52					

MODEL	L	L1	L2	A	B	B1	B2	D	D1	D2	D3	D4	I	I1	I2	I3	M	H	H1	H2	WEIGHT kg
DPH 120/340.65 T	340	138,5	201,5	18	381	82	299	185	145	130	110	65	240	120	120	140	M14	476	238	238	59

## DPH 150/340.65 T - WET ROTOR CIRCULATORS

Pumped liquid temperature range: from -10 °C to +110 °C - Maximum operating pressure: 10 bar (1000 kPa)

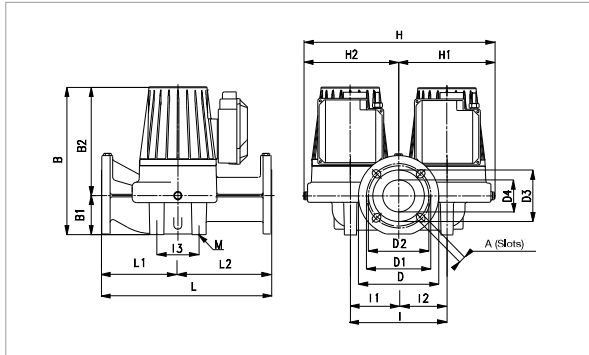

The performance curves are based on kinematic viscosity values = 1 mm<sup>2</sup>/s and density equal to 1000 kg/m<sup>3</sup>. Curve tolerance according to ISO 9906.

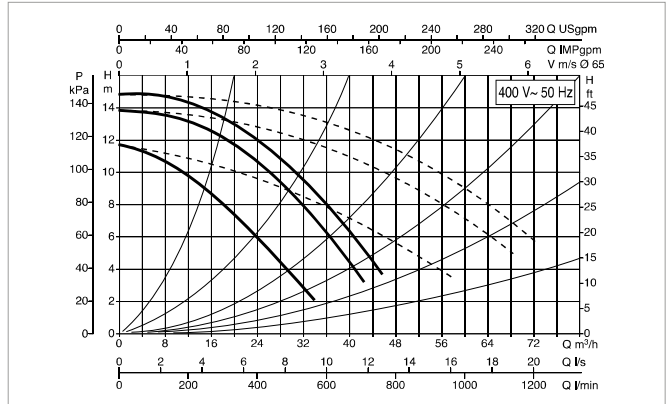

MODEL	CENTRE DISTANCE mm	COUNTERFLANGES ON REQUEST	ELECTRICAL DATA					MINIMUM SUCTION PRESSURE				
			POWER INPUT 50 Hz	SPEED	REV. 1/min	P1 MAX W	In A	t°	75°	90°	110°	120°
DPH 150/340.65 T	340	DN 65 - PN 10	3x230 V ~	2 1	2410 2250	1345 1188	3,8 3,36	m.c.w.	7	11	18	-
			3x400 V ~	3 2 1	2800 2730 2250	1796 1690 1210	3,25 2,93 2					

MODEL	L	L1	L2	A	B	B1	B2	D	D1	D2	D3	D4	I	I1	I2	I3	M	H	H1	H2	WEIGHT kg
DPH 150/340.65 T	340	138,5	201,5	18	381	82	299	185	145	130	110	65	240	120	120	140	M14	476	238	238	59

## DPH 180/340.65 T - WET ROTOR CIRCULATORS

Pumped liquid temperature range: from -10 °C to +110 °C - Maximum operating pressure: 10 bar (1000 kPa)

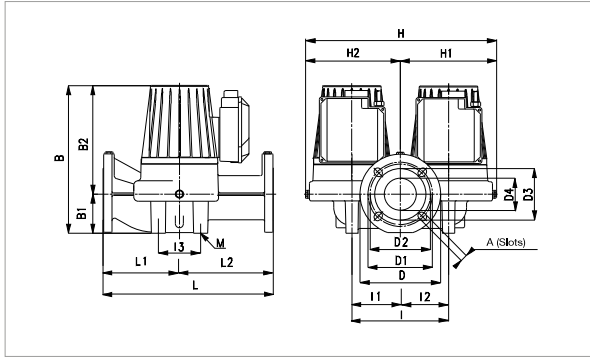

The performance curves are based on kinematic viscosity values = 1 mm<sup>2</sup>/s and density equal to 1000 kg/m<sup>3</sup>. Curve tolerance according to ISO 9906.

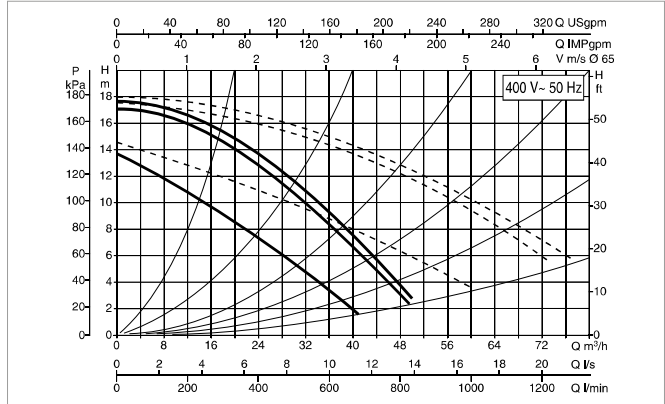

MODEL	CENTRE DISTANCE mm	COUNTERFLANGES ON REQUEST	ELECTRICAL DATA					MINIMUM SUCTION PRESSURE				
			POWER INPUT 50 Hz	SPEED	REV. 1/min	P1 MAX W	In A	t°	75°	90°	110°	120°
DPH 180/340.65 T	340	DN 65 - PN 10	3x230 V ~	2	2380	1670	4,7	m.c.w.	7	11	18	-
			1	2170	1490	4,25						
			3x400 V ~	3	2780	2310	4					
				2	2700	2210	3,5					
				1	2200	1490	2,4					

MODEL	L	L1	L2	A	B	B1	B2	D	D1	D2	D3	D4	I	I1	I2	I3	M	H	H1	H2	WEIGHT kg
DPH 180/340.65 T	340	138,5	201,5	18	381	82	299	185	145	130	110	65	240	120	120	140	M14	476	238	238	59

## DMH 30/360.80 T - WET ROTOR CIRCULATORS

Pumped liquid temperature range: from -10 °C to +120 °C - Maximum operating pressure: 10 bar (1000 kPa)

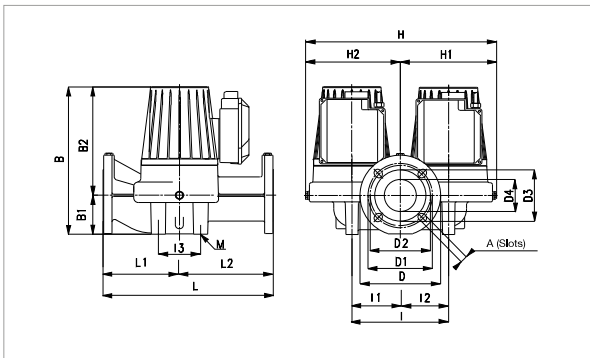

The performance curves are based on kinematic viscosity values = 1 mm<sup>2</sup>/s and density equal to 1000 kg/m<sup>3</sup>. Curve tolerance according to ISO 9906.

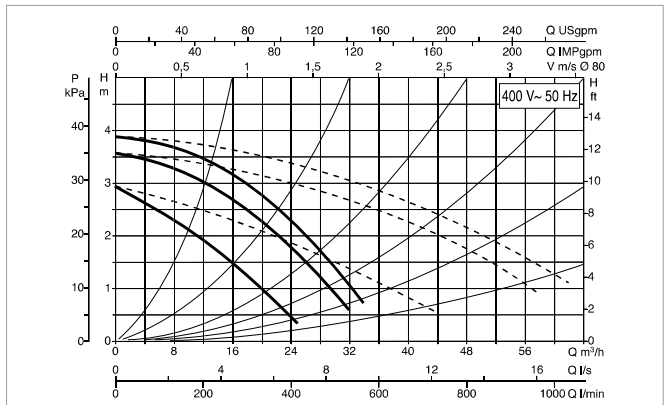

MODEL	CENTRE DISTANCE mm	COUNTERFLANGES ON REQUEST	ELECTRICAL DATA					MINIMUM SUCTION PRESSURE				
			POWER INPUT 50 Hz	SPEED	REV. 1/min	P1 MAX W	In A	t°	75°	90°	110°	120°
DMH 30/360.80 T	360	DN 80 - PN 10	3x230 V ~	2	1110	313	1,05	m.c.w.	4	7,5	-	21
			1	1010	268	0,88						
			3x400 V ~	3	1370	484	1,23					
				2	1330	437	1					
				1	1030	266	0,51					

MODEL	L	L1	L2	A	B	B1	B2	D	D1	D2	D3	D4	I	I1	I2	I3	M	H	H1	H2	WEIGHT kg
DMH 30/360.80 T	360	160	200	18	345	97	248	200	160	150	130	80	240	120	120	150	M14	480	240	240	54,5

## DMH 60/360.80 T - WET ROTOR CIRCULATORS

Pumped liquid temperature range: from -10 °C to +120 °C - Maximum operating pressure: 10 bar (1000 kPa)

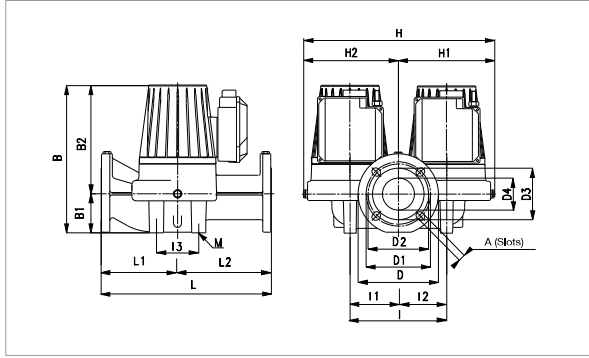

The performance curves are based on kinematic viscosity values = 1 mm<sup>2</sup>/s and density equal to 1000 kg/m<sup>3</sup>. Curve tolerance according to ISO 9906.

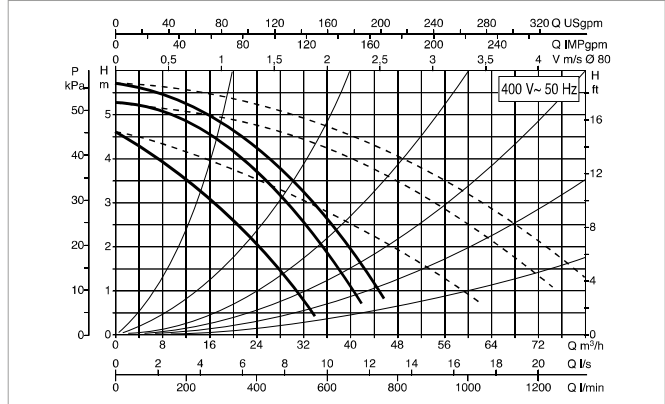

MODEL	CENTRE DISTANCE mm	COUNTERFLANGES ON REQUEST	ELECTRICAL DATA					MINIMUM SUCTION PRESSURE				
			POWER INPUT 50 Hz	SPEED	REV. 1/min	P1 MAX W	In A	t°	75°	90°	110°	120°
DMH 60/360.80 T	360	DN 80 - PN 10	3x230 V ~	2 1	1180 1100	535 465	1,82 1,55	m.c.w.	2	5	-	20
			3x400 V ~	3 2 1	1390 1350 1100	763 675 465	2,04 1,65 0,89					

MODEL	L	L1	L2	A	B	B1	B2	D	D1	D2	D3	D4	I	I1	I2	I3	M	H	H1	H2	WEIGHT kg
DMH 60/360.80 T	360	160	200	18	390	97	298	200	160	150	130	80	240	120	120	150	M14	480	240	240	72

## DPH 120/360.80 T- WET ROTOR CIRCULATORS

Pumped liquid temperature range: from -10 °C to +120 °C - Maximum operating pressure: 10 bar (1000 kPa)

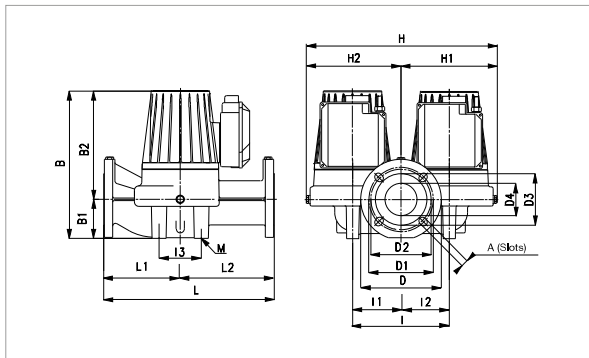

The performance curves are based on kinematic viscosity values = 1 mm<sup>2</sup>/s and density equal to 1000 kg/m<sup>3</sup>. Curve tolerance according to ISO 9906.

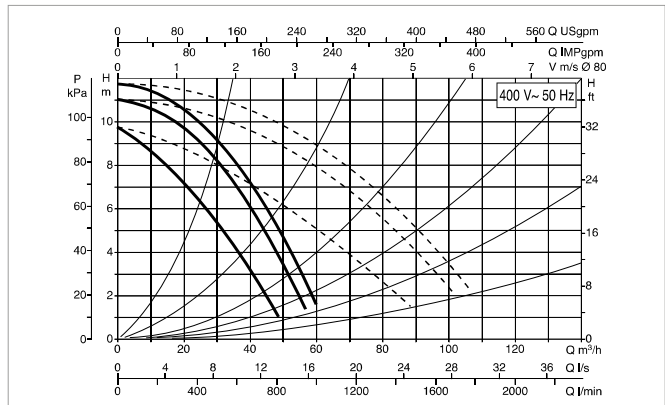

MODEL	CENTRE DISTANCE mm	COUNTERFLANGES ON REQUEST	ELECTRICAL DATA					MINIMUM SUCTION PRESSURE				
			POWER INPUT 50 Hz	SPEED	REV. 1/min	P1 MAX W	In A	t°	75°	90°	110°	120°
DPH 120/360.80 T	360	DN 80 - PN 10	3x230 V ~	2 1	2500 2340	1410 1292	3,95 3,6	m.c.w.	6	10	-	22
			3x400 V ~	3 2 1	2830 2780 2350	1820 1710 1302	3,3 2,93 2,13					

MODEL	L	L1	L2	A	B	B1	B2	D	D1	D2	D3	D4	I	I1	I2	I3	M	H	H1	H2	WEIGHT kg
DPH 120/360.80 T	360	160	200	18	390	97	298	200	160	150	130	80	240	120	120	150	M14	480	240	240	72

## DPH 150/360.80 T - WET ROTOR CIRCULATORS

Pumped liquid temperature range: from -10 °C to +110 °C - Maximum operating pressure: 10 bar (1000 kPa)

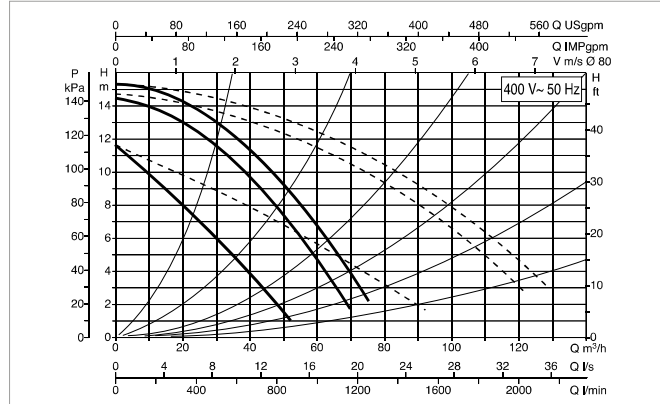
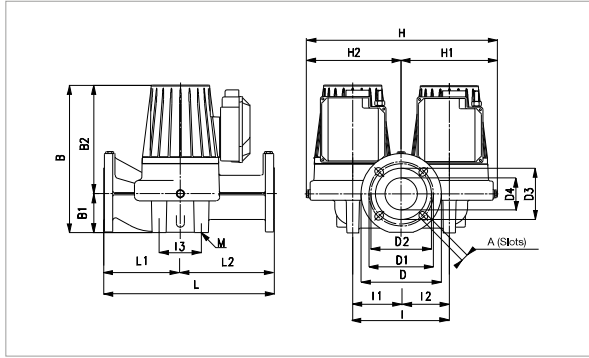

The performance curves are based on kinematic viscosity values = 1 mm<sup>2</sup>/s and density equal to 1000 kg/m<sup>3</sup>. Curve tolerance according to ISO 9906.

MODEL	CENTRE DISTANCE mm	COUNTERFLANGES ON REQUEST	ELECTRICAL DATA					MINIMUM SUCTION PRESSURE				
			POWER INPUT 50 Hz	SPEED	REV. 1/min	P1 MAX W	In A	t°	75°	90°	110°	120°
DPH 150/360.80 T	360	DN 80 - PN 10	3x230 V ~	2	2140	1984	5.62	m.c.w.	7	11	18	-
			1	1900	1695	4.82						
			3x400 V ~	3	2710	2870	4.64					
				2	2610	2686	4.32					
				1	1940	1710	2.85					

MODEL	L	L1	L2	A	B	B1	B2	D	D1	D2	D3	D4	I	I1	I2	I3	M	H	H1	H2	WEIGHT kg
DPH 150/360.80 T	360	160	200	18	390	97	298	200	160	150	130	80	240	120	120	150	M14	480	240	240	72

## DPH 180/360.80 T - WET ROTOR CIRCULATORS

Pumped liquid temperature range: from -10 °C to +110 °C - Maximum operating pressure: 10 bar (1000 kPa)

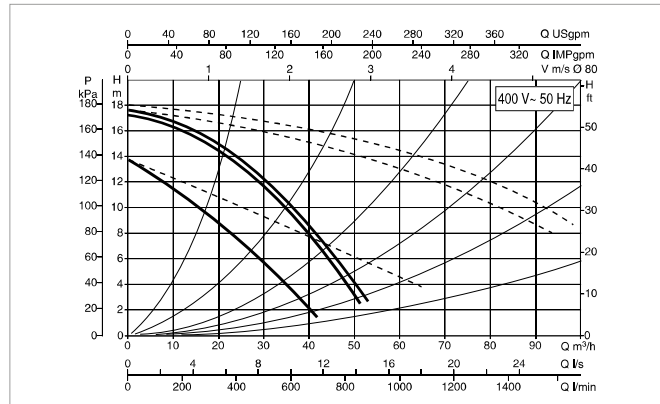
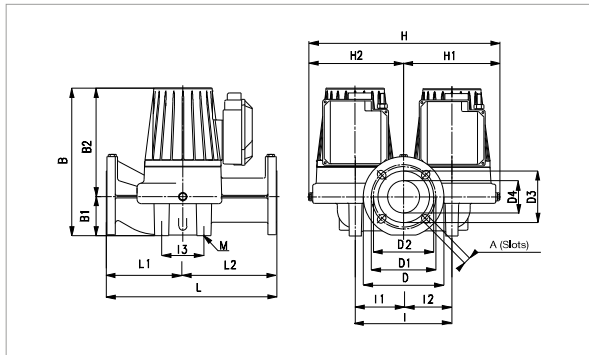

The performance curves are based on kinematic viscosity values = 1 mm<sup>2</sup>/s and density equal to 1000 kg/m<sup>3</sup>. Curve tolerance according to ISO 9906.

MODEL	CENTRE DISTANCE mm	COUNTERFLANGES ON REQUEST	ELECTRICAL DATA					MINIMUM SUCTION PRESSURE				
			POWER INPUT 50 Hz	SPEED	REV. 1/min	P1 MAX W	In A	t°	75°	90°	110°	120°
DPH 180/360.80 T	360	DN 80 - PN 10	3x230 V ~	2	2380	1670	4.7	m.c.w.	7	11	18	-
			1	2170	1490	4.25						
			3x400 V ~	3	2780	2310	4					
				2	2700	2210	3.5					
				1	2200	1490	2.4					

MODEL	L	L1	L2	A	B	B1	B2	D	D1	D2	D3	D4	I	I1	I2	I3	M	H	H1	H2	WEIGHT kg
DPH 180/360.80 T	360	160	200	18	390	97	298	200	160	150	130	80	240	120	120	150	M14	480	240	240	72

# DWA

P U M P S S E L E C T O R

On-line product selection



**DAB PUMPS LTD.**  
6 Gilberd Court  
Newcomen Way  
Severalls Business Park  
Colchester  
Essex  
CO4 9WN - UK  
salesuk@dwtgroup.com  
Tel. +44 0333 777 5010



**DAB PUMPS IBERICA S.L.**  
Calle Verano 18-20-22  
28850 - Torrejón de Ardoz - Madrid  
Spain  
Info.spain@dwtgroup.com  
Tel. +34 91 6569545  
Fax: + 34 91 6569676



**DAB PUMPS SOUTH AFRICA (PTY) LTD**  
Twenty One Industrial Estate,  
16 Purlin Street, Unit B, Warehouse 4  
Olifantsfontein - 1666 - South Africa  
info.sa@dwtgroup.com  
Tel. +27 12 361 3997



**DAB PUMPS BV**  
'tHofveld 6 C1  
1702 Groot Bijgaarden - Belgium  
info.belgium@dwtgroup.com  
Tel. +32 2 4668353



**DAB PUMPS HUNGARY KFT.**  
H-8800  
Nagykanizsa, Buda Ernő u.5  
Hungary  
Tel. +36 93501700



**DAB PUMPS (QINGDAO) CO. LTD.**  
No.40 Kaituo Road, Qingdao Economic & Technological  
Development Zone  
Qingdao City, Shandong Province - China  
PC: 266500  
sales.cn@dwtgroup.com  
Tel. +86 400 186 8280  
Fax +86 53286812210



**DAB PUMPS B.V.**  
Albert Einsteinweg, 4  
5151 DL Drunen - Nederland  
info.netherlands@dwtgroup.com  
Tel. +31 416 387280  
Fax +31 416 387299



**DAB PUMPS POLAND Sp. z o.o.**  
Ul. Janka Muzykanta 60  
02-188 Warszawa - Poland  
polska@dabpumps.com.pl



**DAB PUMPS DE MÉXICO, S.A. DE C.V.**  
Av Amsterdam 101 Local 4  
Col. Hipódromo Condesa,  
Del. Cuauhtémoc CP 06170  
Ciudad de México  
Tel. +52 55 6719 0493



**OOO DAB PUMPS**  
Novgorodskaya str. 1, block G  
office 308, 127247, Moscow - Russia  
info.russia@dwtgroup.com  
Tel. +7 495 122 0035  
Fax +7 495 122 0036



**DAB PUMPEN DEUTSCHLAND GmbH**  
Tackweg 11  
D - 47918 Tönisvorst - Germany  
info.germany@dwtgroup.com  
Tel. +49 2151 82136-0  
Fax +49 2151 82136-36



**DAB PUMPS INC.**  
3226 Benchmark Drive  
Ladson, SC 29456 - USA  
info.usa@dwtgroup.com  
Tel. 1- 843-797-5002  
Fax 1-843-797-3366



**DAB PUMPS OCEANIA PTY LTD**  
426 South Gippsland Hwy,  
Dandenong South VIC 3175 - Australia  
info.oceania@dwtgroup.com  
Tel. +61 1300 378 677