



PERFORMANCE CURVES

2025-02-04

Page 2 / 3

DAB PUMPS S.p.A.
Via Marco Polo, 14 - 35035 Mestrino (PD), Italy
Tel. +39 049 5125000 - Fax +39 049 5125950
www.dabpumps.com

Receiver

From

Company
Reference
Address
Phone
Fax
E-mail

GRINDER FX 15.22 T-NA 400 V

Curve tolerance according to ISO 9906

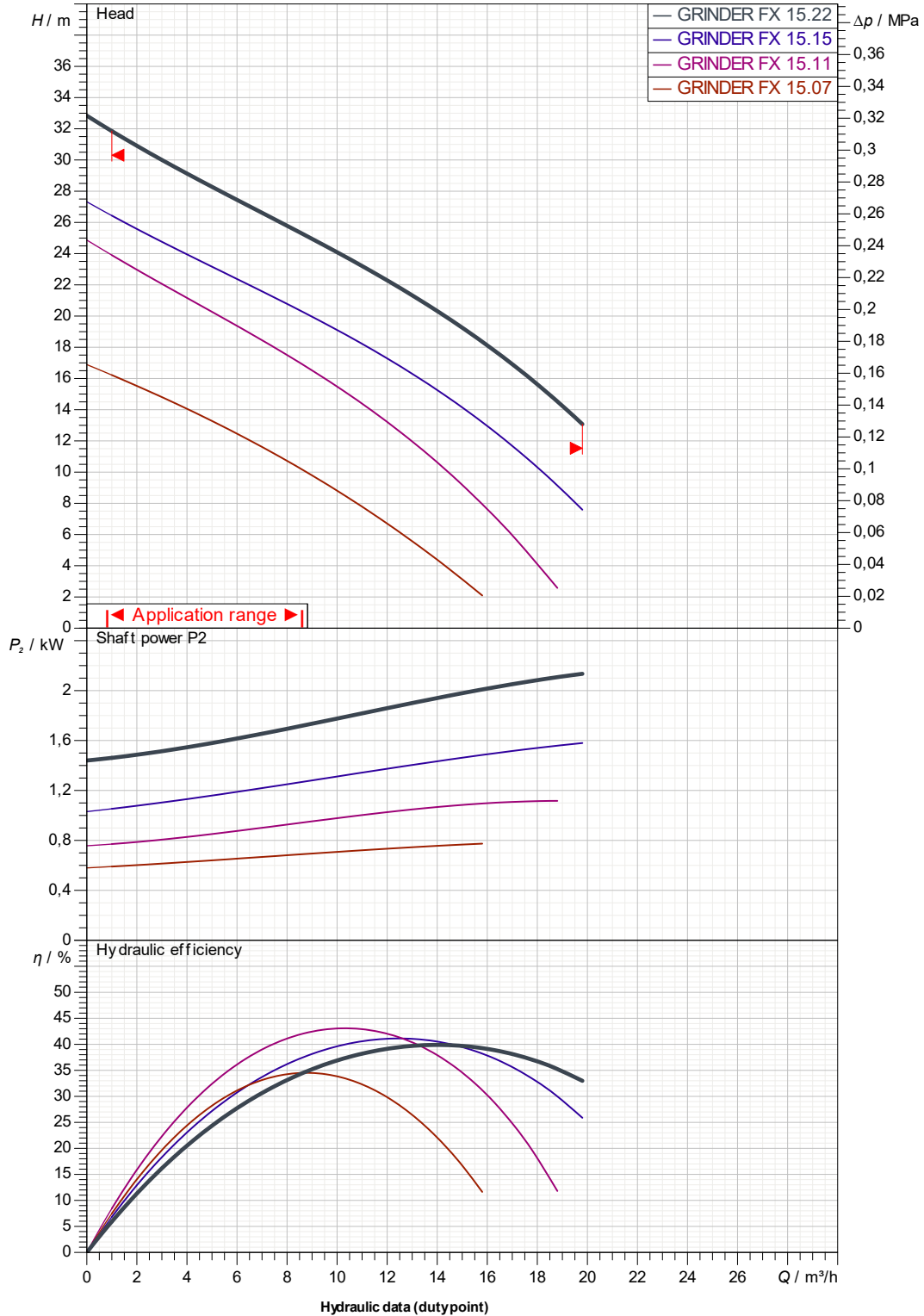

Suction side :

Discharge side :
Rp 1"1/2 - DN 32 PN10/6, DN 40 PN6
--

Flow :

Head :

Rated speed :
2.870 1/min

MAIN_PROJECT_TITLE

BUSINESS_PROCESS_ID

OWNER_

ISSUE_DATE
2025-02-04



DIMENSIONAL DRAWING

2025-02-04

Page 3 / 3

DAB PUMPS S.p.A.
Via Marco Polo, 14 - 35035 Mestrino (PD), Italy
Tel. +39 049 5125000 - Fax +39 049 5125950
www.dabpumps.com

Receiver

From

Company
Reference
Address
Phone
Fax
E-mail

GRINDER FX 15.22 T-NA 400 V

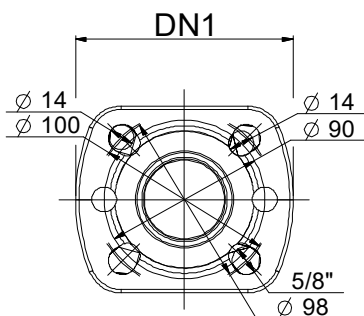
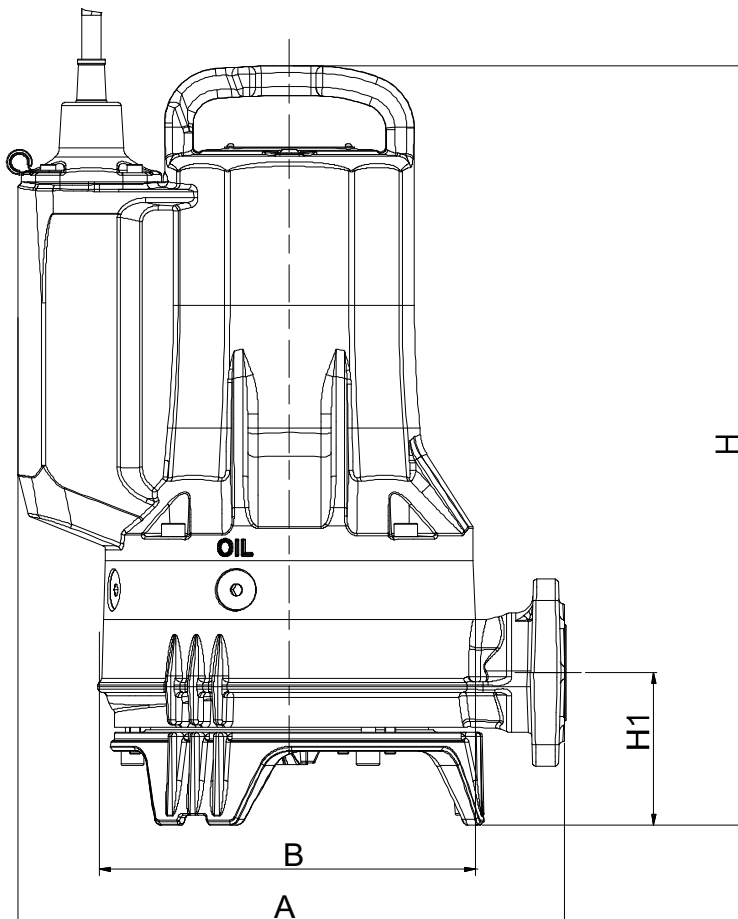

Dimensions in mm

Pump connection

1
2
3
4
5
6
7
8
9
10
11

A	306
B	215
DN1	32, 40
GAS	Rp 1"1/2
H	430
H1	87

Suction
Discharge
Rp 1"1/2 - DN 32 PN10/6, DN 40 PN6
--

MAIN_PROJECT_TITLE

BUSINESS_PROCESS_ID

OWNER_

ISSUE_DATE

2025-02-04